

# ASSEMBLY INSTRUCTIONS

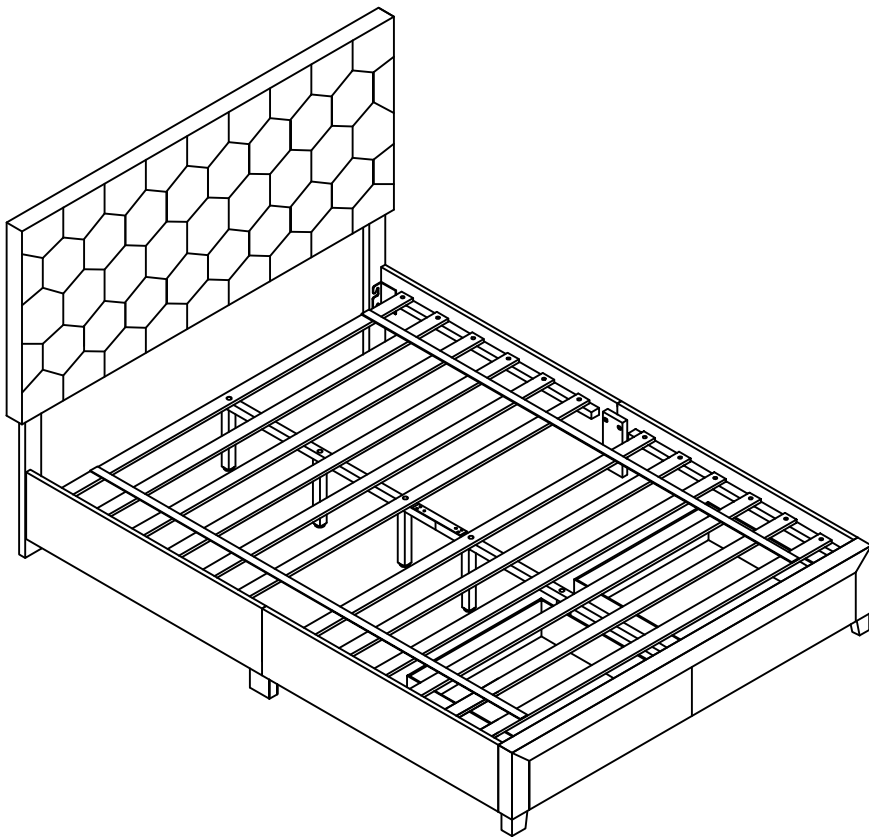

## TOOLS REQUIRED



Allen Wrench

(Included)

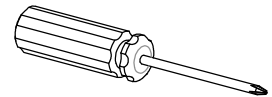

Phillips Screwdriver

(Not Included)



3 - People  
Recommended

## ASSEMBLY RATING



EASY —————> DIFFICULT

The Assembly Rating is a 5-point system showing the level of effort needed to assemble a specific product.



## **CHECK BEFORE STARTING**

### **Are you missing anything?**

Double-check all parts, hardware and accessories listed are all accounted for.

### **Check out our Quick Tips!**

We recommend reviewing the pre-assembly handouts. Even experts need a refresher now and then!

### **Should we send any replacements?**

Are there any irregularities or flaws in the parts? We can send replacements!

### **Prep Time!**

Please review the assembly instructions and all diagrams prior to assembling.

# PRE ASSEMBLY INTRODUCTION

We understand building ready-to-assemble furniture can be a challenging experience for some. To help avoid confusion, we have provided some helpful tips that may speed up the process.

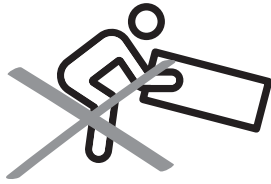

## Teamwork

ALWAYS have at least two people to help with transporting and assembling the product to avoid potential injury and/or damage.

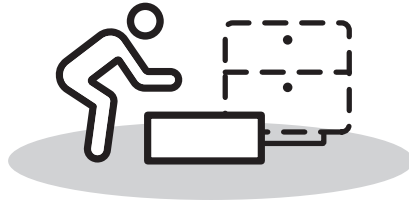
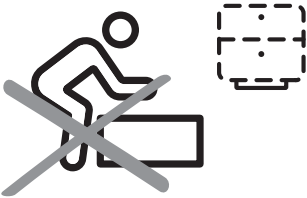

## Suitable Location

Assembling near the area of the intended location is highly recommended.



## Sufficient Space

Make sure you have enough space to move around during the assembly.



## Avoid Scratches

Use cardboard, blankets or a carpeted area while assembling furniture to prevent to prevent scratches and damages.

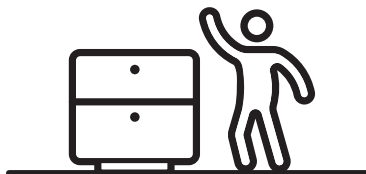
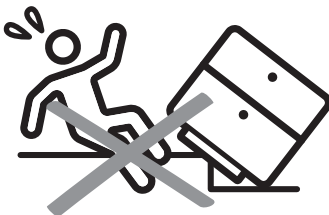

## Flat Surface

Make sure the furniture rests on a flat and level surface with each leg evenly touching the floor.

# ASSEMBLY AND CARE ADVICE



**FAILURE TO FOLLOW THE GUIDELINES BELOW MAY RESULT IN INJURY AND/OR PROPERTY DAMAGE.**



Position each part correctly and insert screws or bolts into their respective holes.

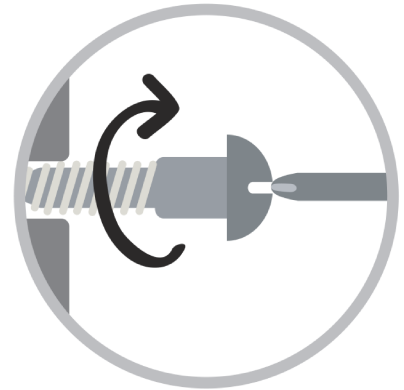

Turn clockwise to tighten and only tighten when step is completed or when instructed to do so.



Use the appropriate hand tools or power tools for assembly. Select steps, such as tightening screws and/or bolts, may require hand tools to avoid causing damage during assembly.



Save the instructions and store any supplied tools for later maintenance.

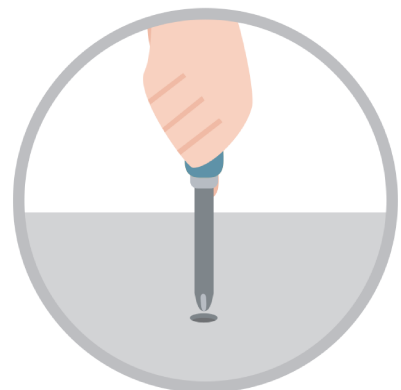

After two weeks, check and tighten any loose hardware and repeat again every six months thereafter.

**IT IS THE USER'S RESPONSIBILITY TO MAINTAIN THE FURNITURE. THE HARDWARE MAY LOOSEN OVER TIME AND MAY CAUSE THE FURNITURE TO BE WOBBLY AND UNABLE TO SUPPORT ITS INTENDED WEIGHT CAPACITY. THIS MAY LEAD TO COLLAPSE AND MAY CAUSE SERIOUS INJURY.**

# BED



- Please keep instructions for future reference.
- Check the quantity and irregularity of parts and hardware before you start.

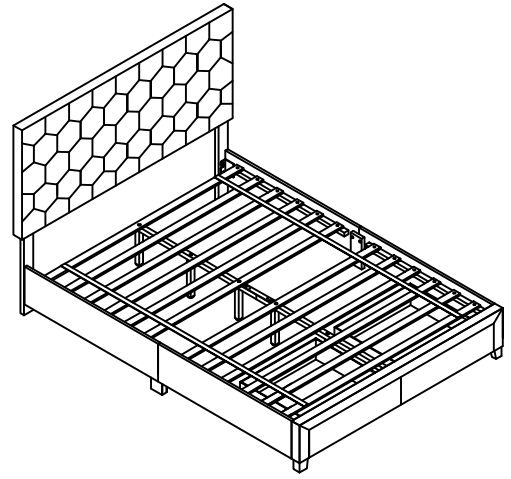

## PARTS

#1 1pc

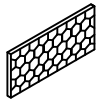

Headboard Panel

#2 1pc

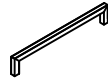

Footboard

#3 2pcs



Side Rail A

#4 2pcs

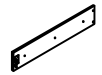

Side Rail B

#5 2pcs

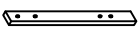

Headboard Leg

#6 2pcs



Footboard Leg

#7 6pcs

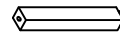

Support Leg

#8 2pcs



Center Support Tube

#9 2pcs



Side Rail Support panel

#10 1Set

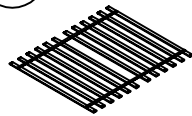

Slat ( 12pcs )

#11 2pcs

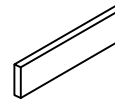

Drawer front panel

#12 2pcs

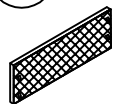

Drawer back panel

#13 2pcs

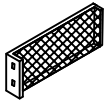

Drawer side panel (A)

#14 2pcs

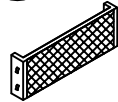

Drawer side panel (B)

#15 2pcs

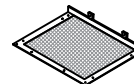

Drawer bottom panel

#16 1pc



Footboard Support panel

#17 4pcs



Side Rail Support Bar

# BED



- Please keep instructions for future reference.
- Check the quantity and irregularity of parts and hardware before you start.

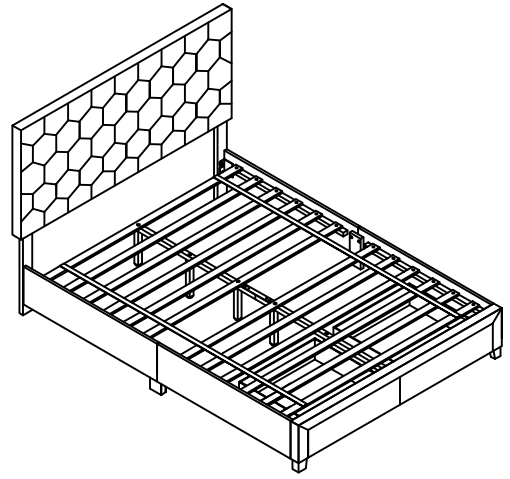

## HARDWARE

#A 16pcs



Bolt 5/16" x 1-3/8"

#B 6pcs



Bolt 5/16" x 2-5/8"

#C 12pcs



Bolt 5/16" x 2"

#D 40pcs



Lock Washer

#E 40pcs



Flat Washer

#F 24pcs



Screw

#G 1pc



Allen Wrench

#H 1pc



Connect plate

#I 8pcs



Drawer Wheel

#J 16pcs



Drawer Screw

#K 18pcs



Drawer Screw

#L 4pcs



Toggle clip

#M 4pcs



Screw

#N 2pcs



Bolt 5/16" x 1"

#O 4pcs



Bolt 5/16" x 2-1/4"

# ASSEMBLY INSTRUCTIONS

1

- Part #1 x1pc
- Part #5 x2pcs
- Hardware #D x4pcs
- Hardware #E x4pcs
- Hardware #O x4pcs

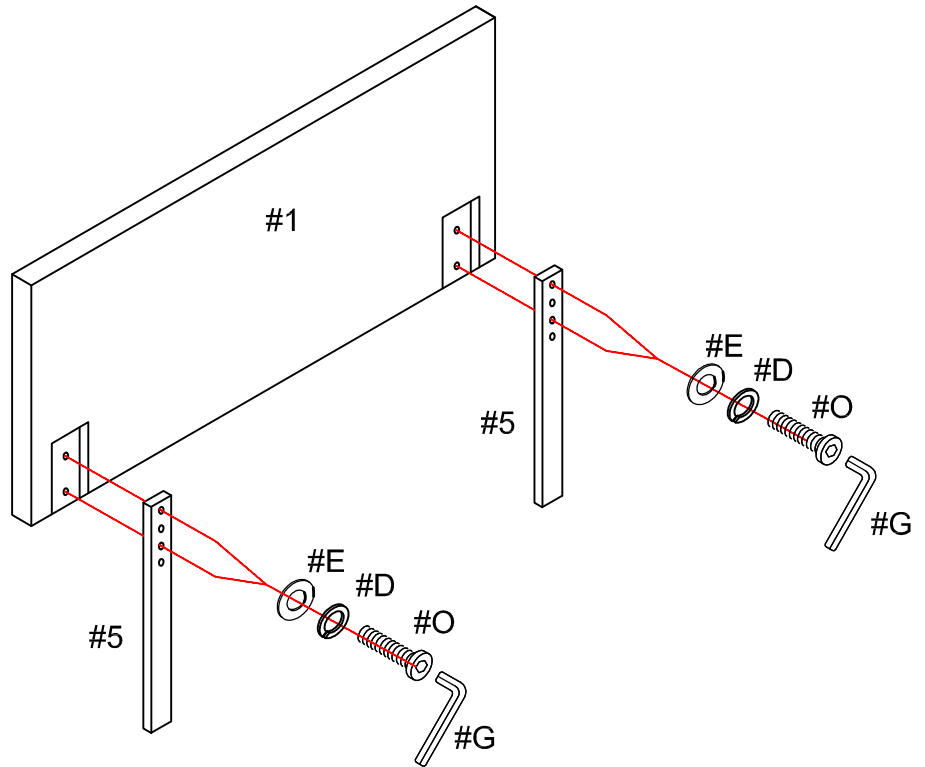

2

- Part #2 x1pc
- Part #16 x1pc
- Hardware #D x 2pcs
- Hardware #E x 2pcs
- Hardware #M x 4pcs
- Hardware #N x 2pcs

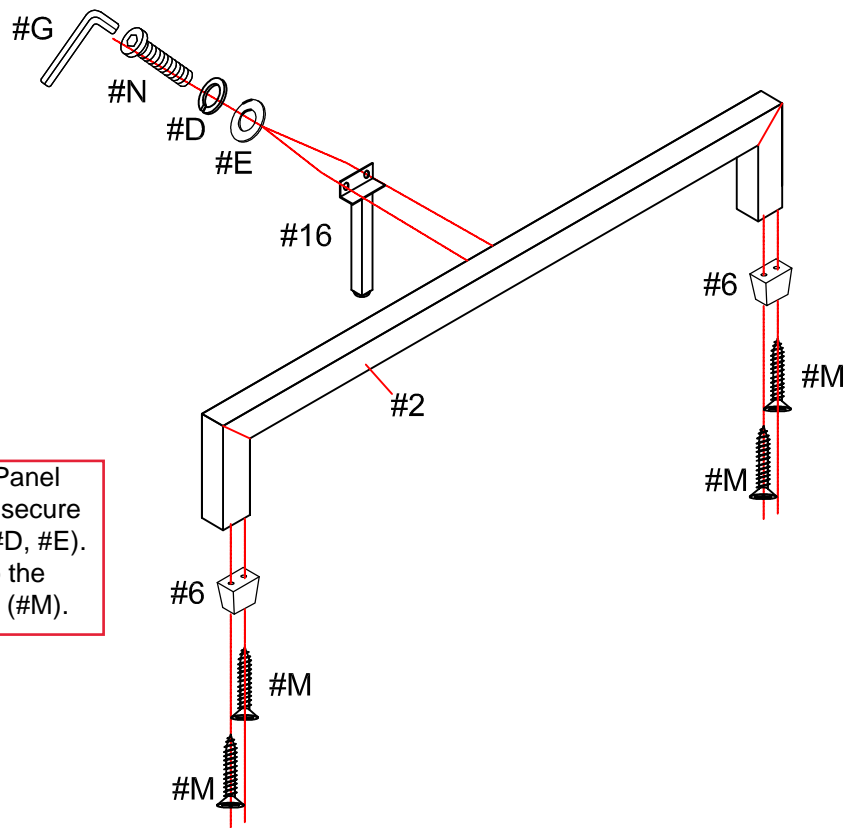

I. Align the Footboard Support Panel (#16) to the Footboard (#2) and secure using Bolts (#N) with washers (#D, #E).  
 II. Secure Footboard Leg (#6) to the Footboard (#2) by using Screws (#M).

# ASSEMBLY INSTRUCTIONS

## 3

- Part #3 x2pcs
- Part #4 x2pcs
- Hardware #A x 8pcs
- Hardware #C x 12pcs
- Hardware #D x 20pcs
- Hardware #E x 20pcs

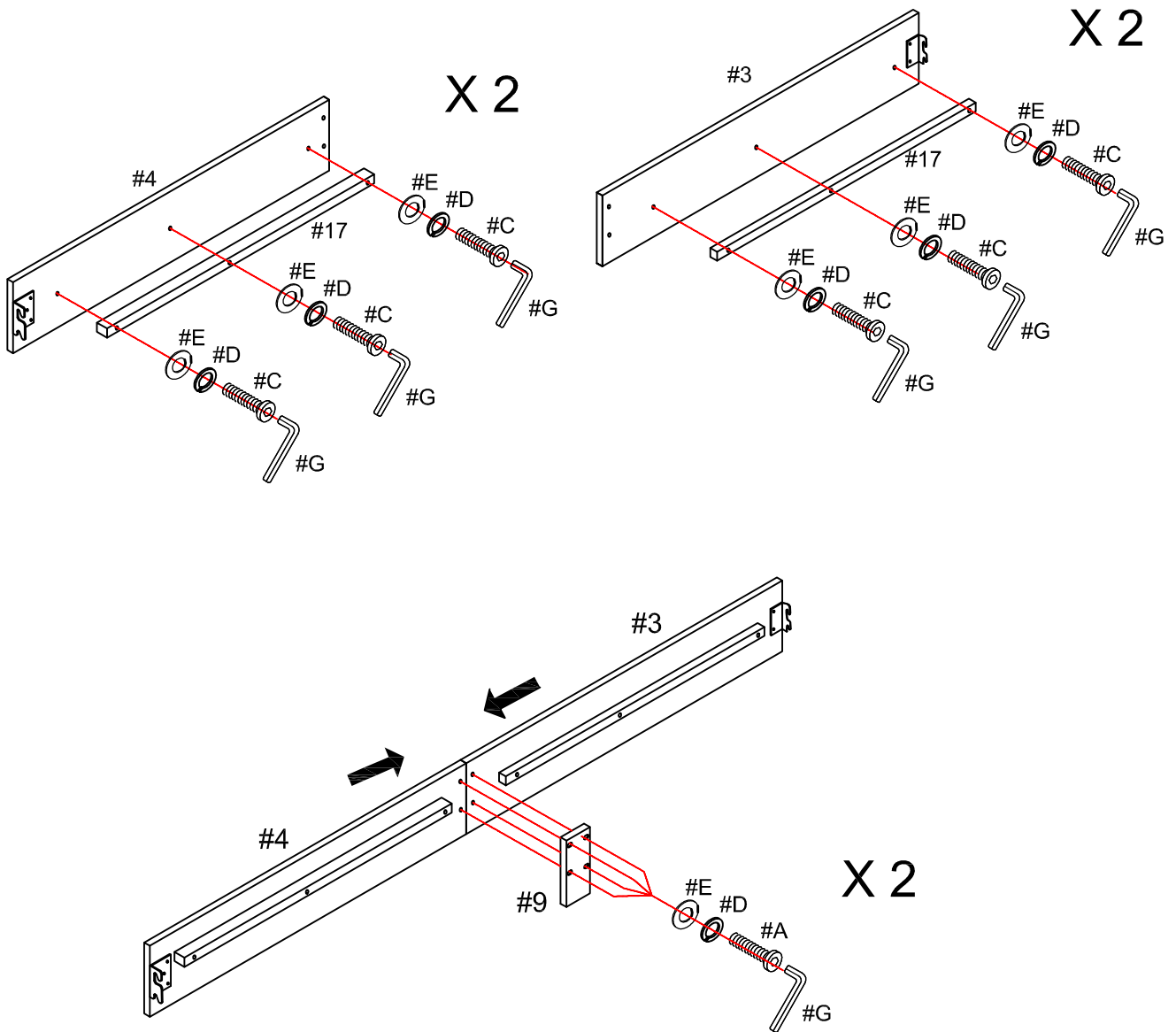



# ASSEMBLY INSTRUCTIONS

Insert Bolt (#A) with washers (#D,E) on the Headboard Leg/  
Footboard (#2, #5). Hook Rails (#3, #4) onto the Bolt assembly,  
then tighten the bolts to secure rails.

## 4

- Hardware #A x 8pcs
- Hardware #D x 8pcs
- Hardware #E x 8pcs

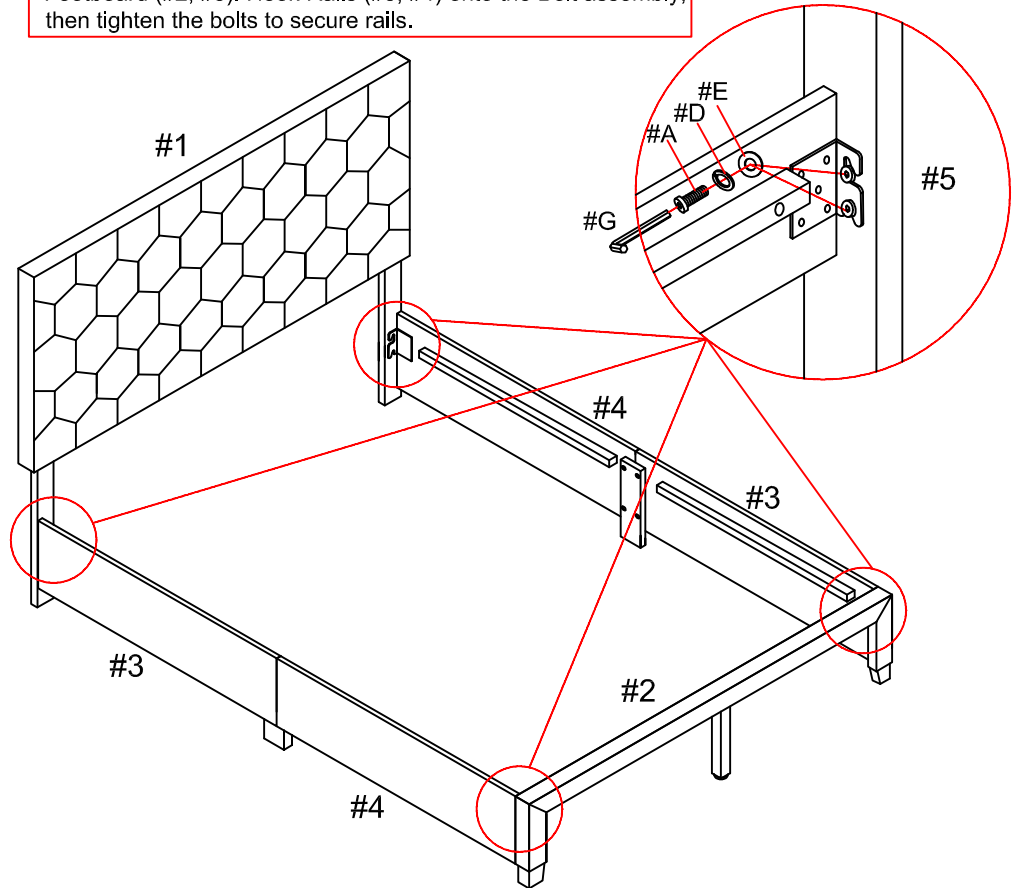

## 5

- Part #7 x2pcs
- Part #8 x2pcs
- Hardware #B x 2pcs
- Hardware #D x 2pcs
- Hardware #E x 2pcs
- Hardware #H x 1pc
- Hardware #K x 6pcs

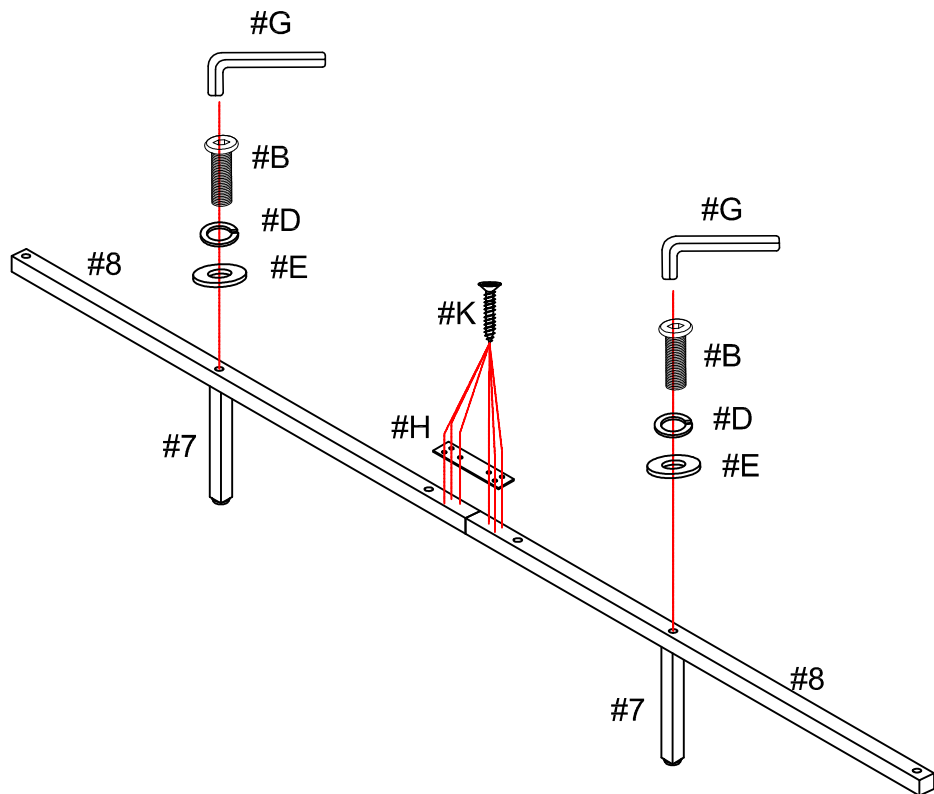

# ASSEMBLY INSTRUCTIONS

## 6

- Part **#7** x4pcs
- Part **#10** x1Set
- Hardware **#B** x 4pcs
- Hardware **#D** x 4pcs
- Hardware **#E** x 4pcs

Attach the other Support Legs (#7) to the Center support tube (#8) and Slats (#10) by using Bolts (#B) with washers (#D, #E).

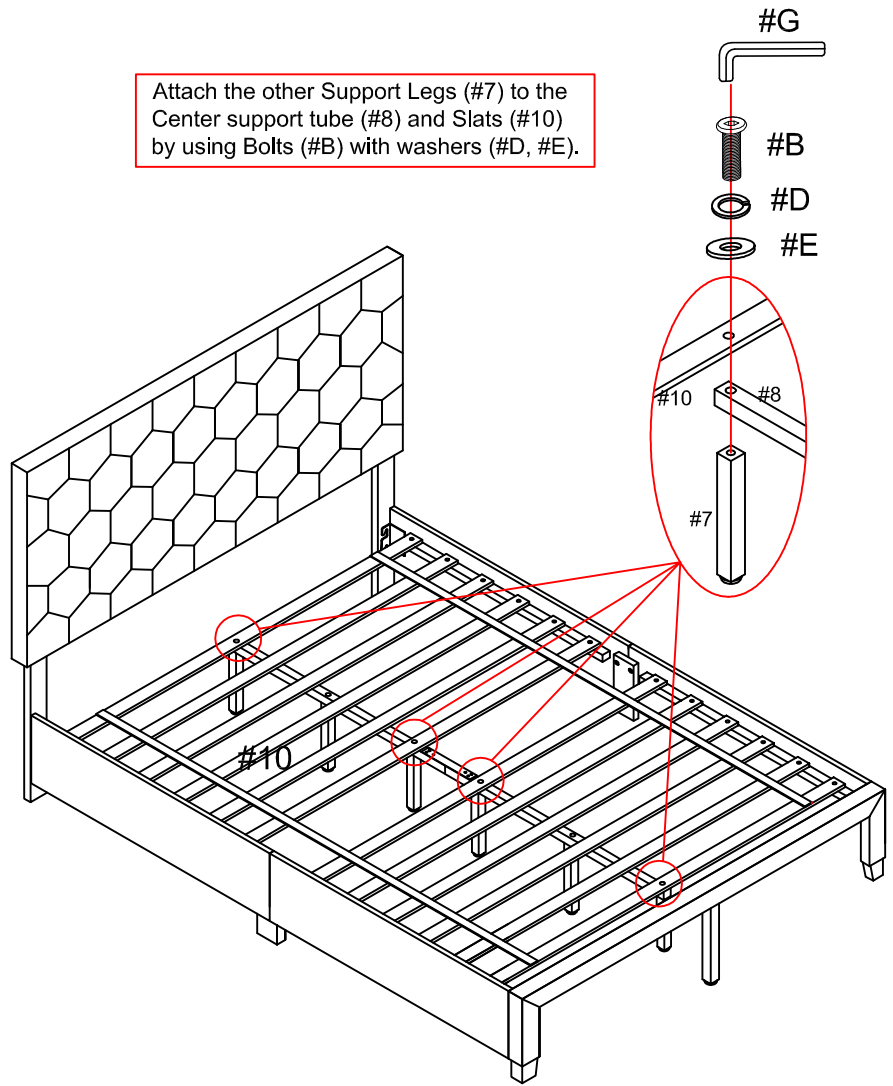

## 7

- Hardware **#F** x 24pcs

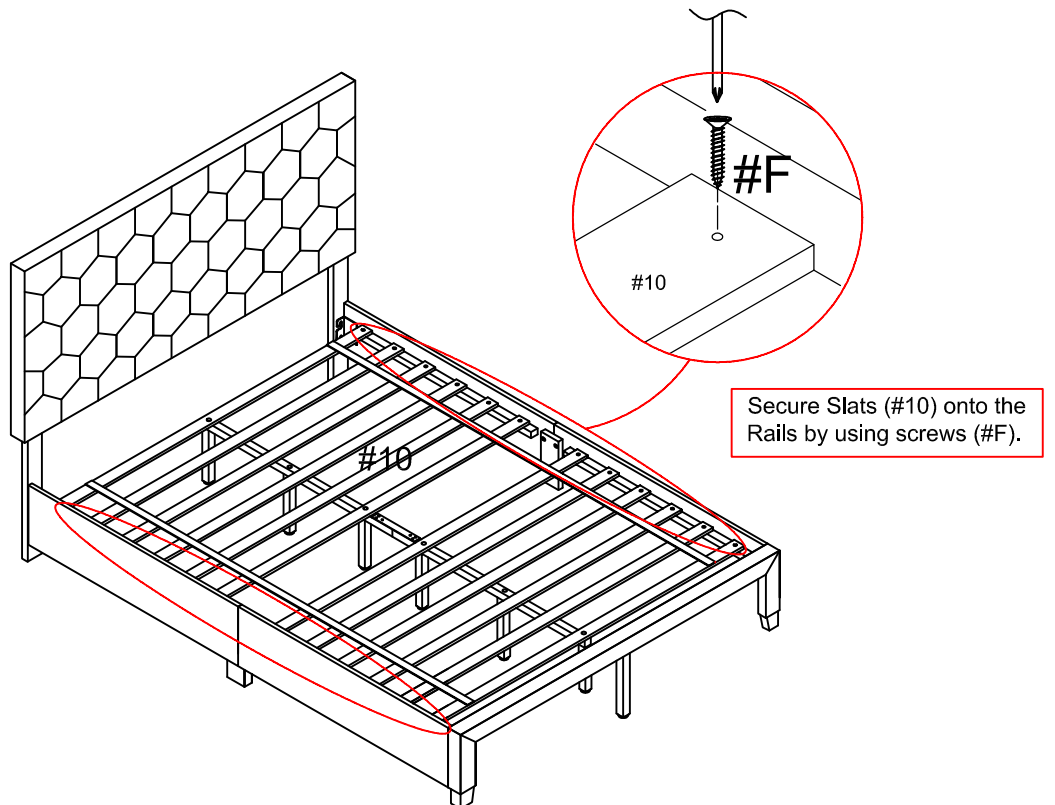

# ASSEMBLY INSTRUCTIONS

## 8

- Part **#12** x 2pcs
- Part **#13** x 2pcs
- Part **#14** x 2pcs

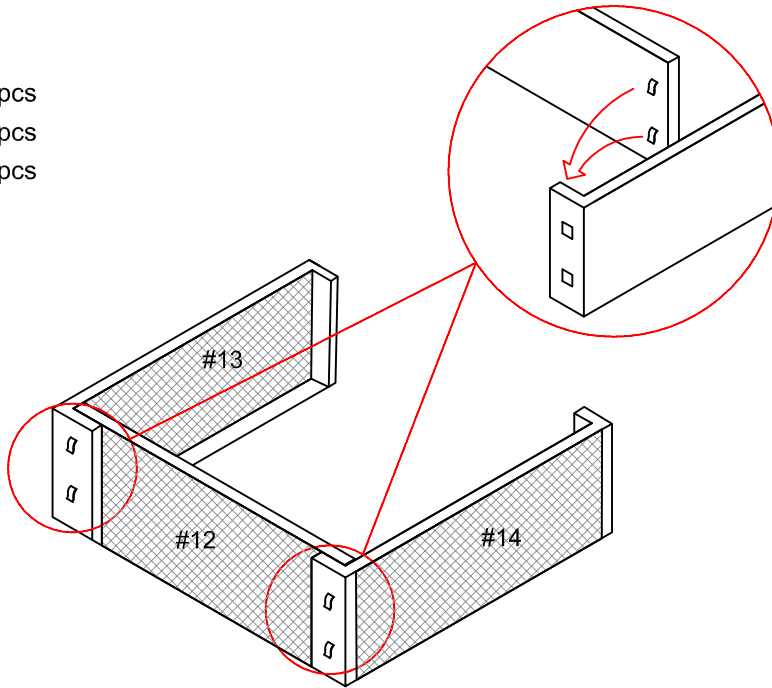

X 2

## 9

- Part **#15** x 2pcs
- Hardware **#I** x 8pcs
- Hardware **#J** x 16pcs

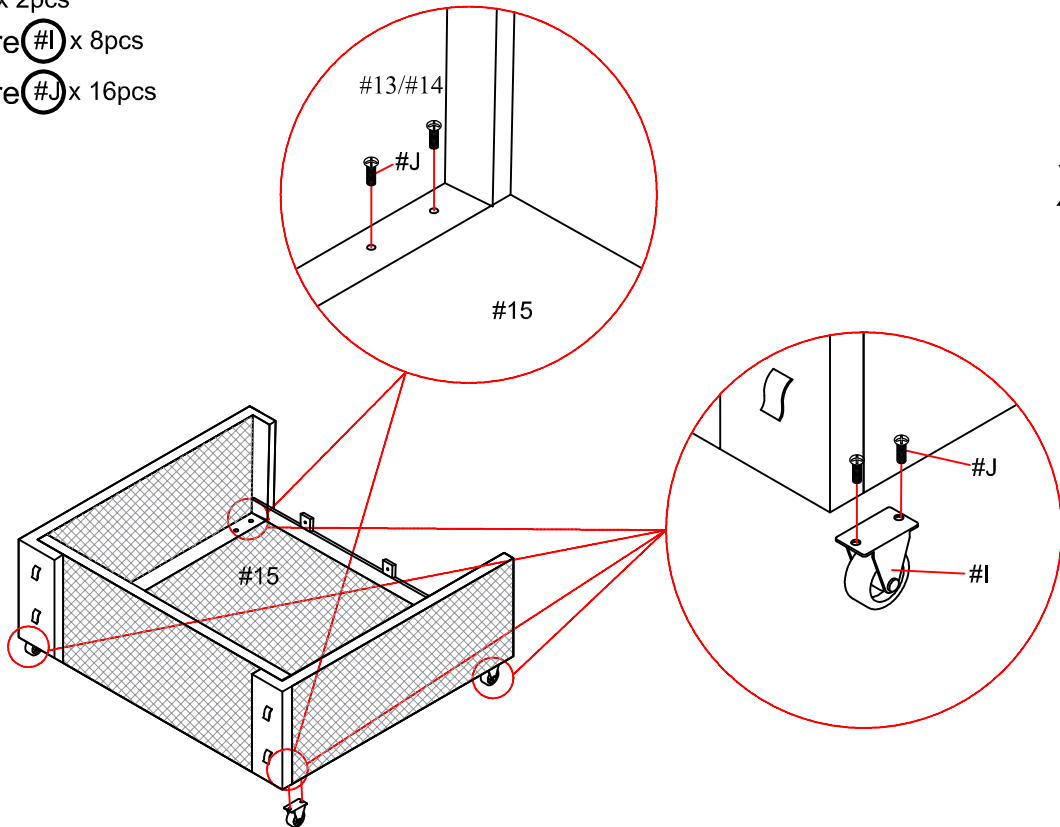

X 2

# ASSEMBLY INSTRUCTIONS

## 10

Part #11 x 2pcs

Hardware #K x 12pcs

Hardware #L x 4pcs

Secure the Drawer front panel (#11) to the drawer assembly by using Screws (#K). Attach toggle clips (#L) to the the Drawer bottom panel (#15).

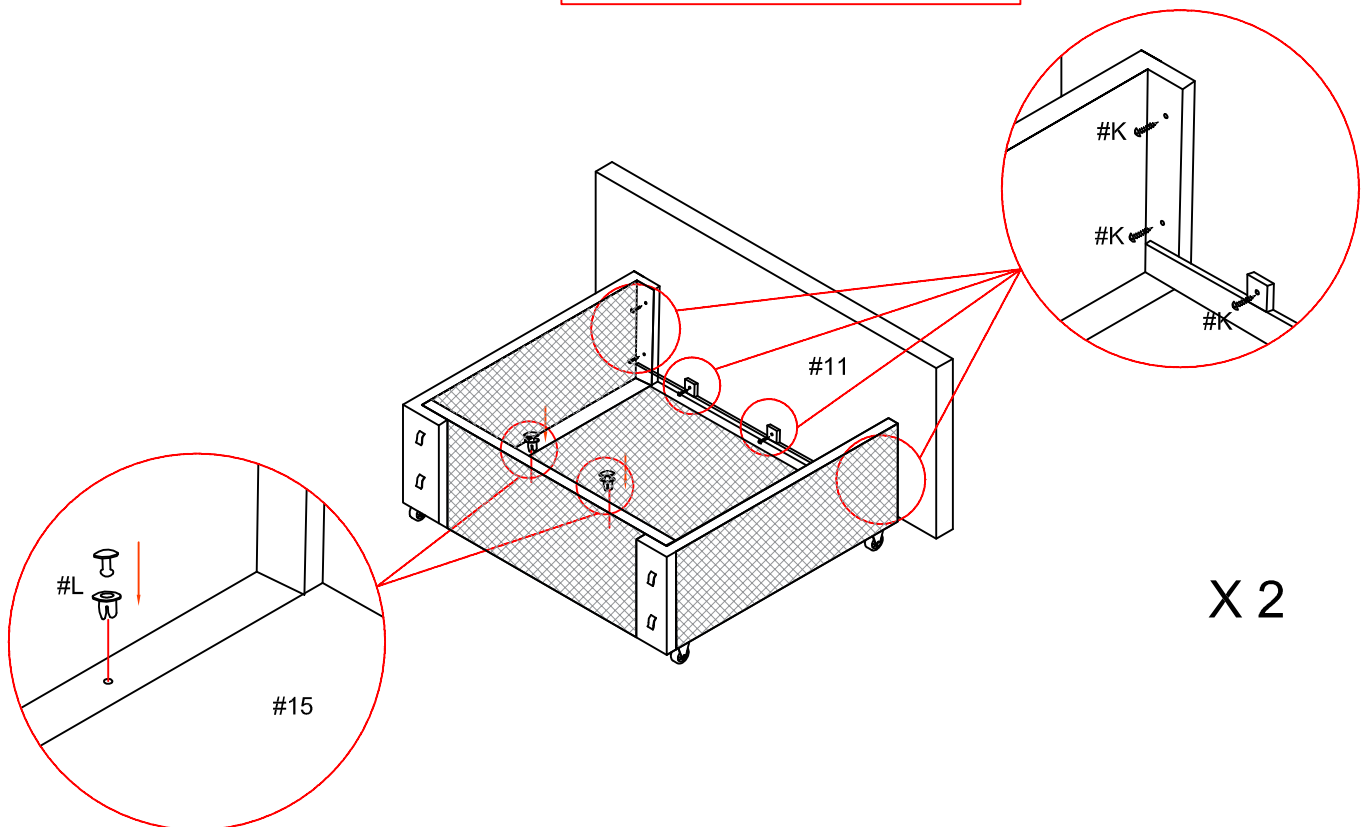

# ASSEMBLY INSTRUCTIONS

11

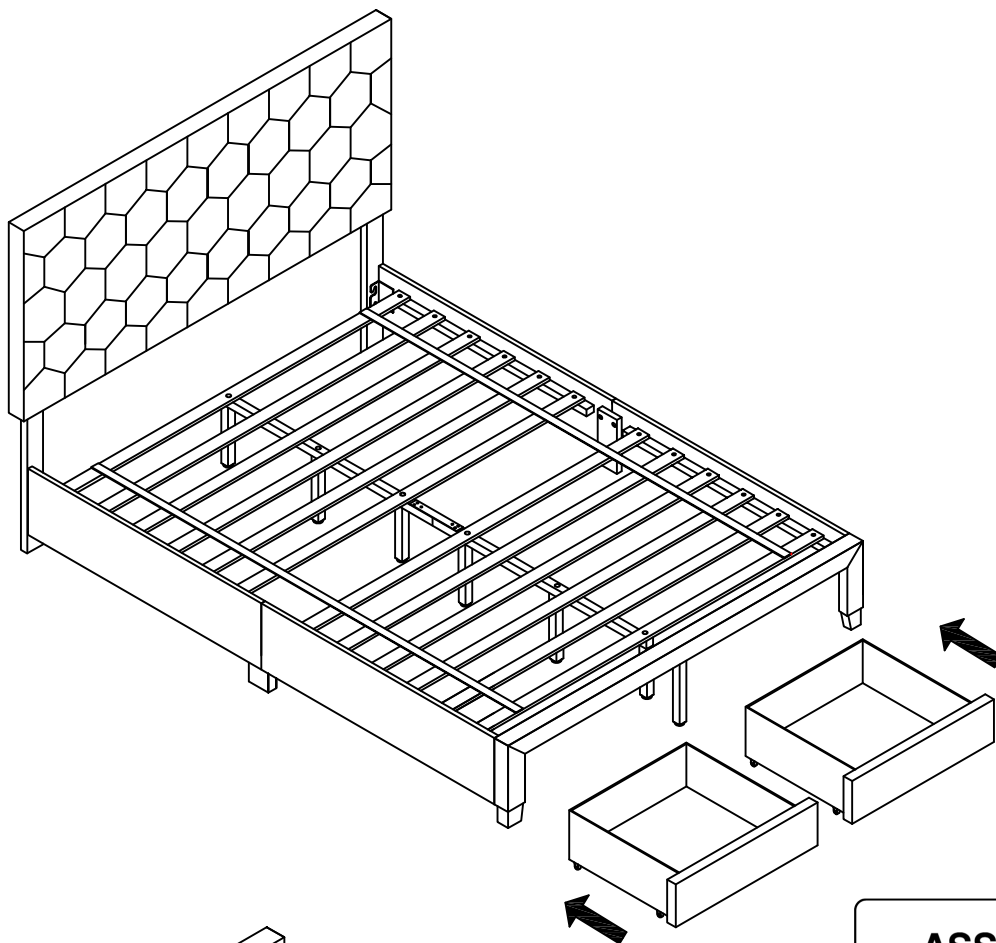

12

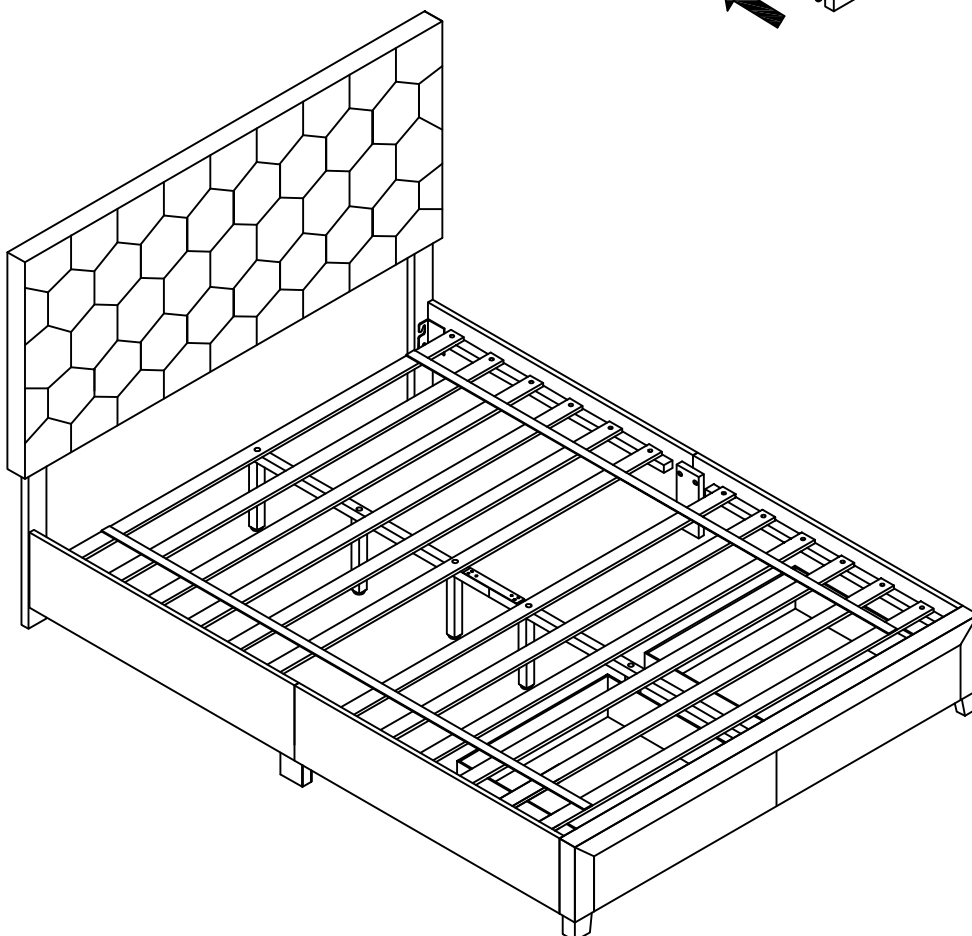

## ASSEMBLY COMPLETED



Please ensure the furniture rests on an even and flat surface. If the product wobbles or feels loose, double-check all bolts and/or screws are properly tightened and secured.



### Keep this handy!

Please retain this instruction manual and any order-related information for future reference.



### Lift, don't drag!

To avoid damage to product please always LIFT the product when transporting or adjusting the placement.