

# ASSEMBLY INSTRUCTIONS

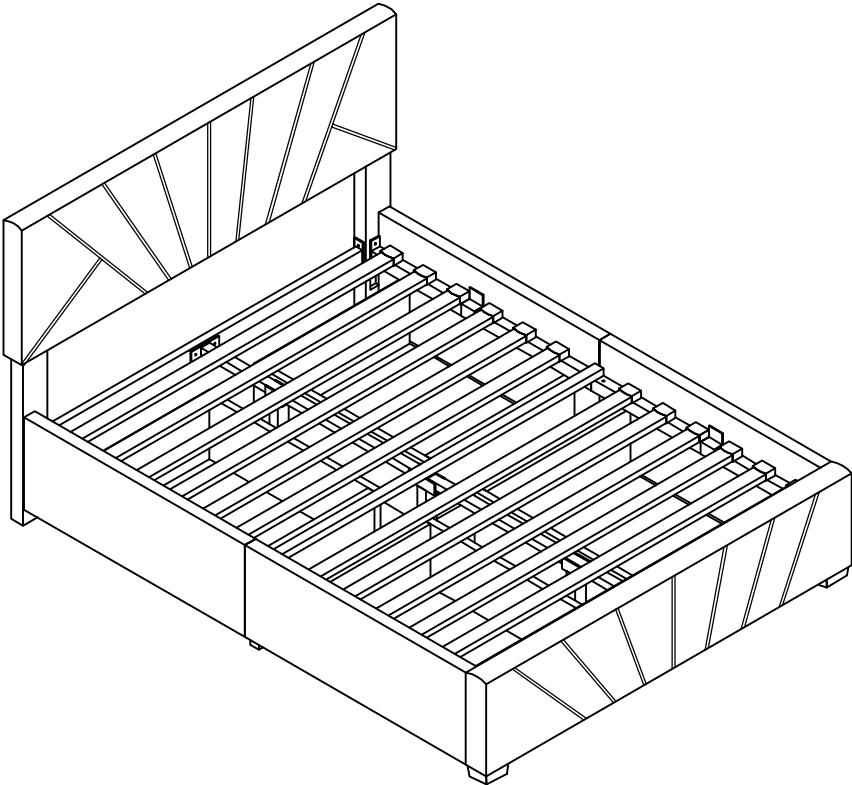

## TOOLS REQUIRED



Allen Wrench  
(Included)



Phillips  
Screwdriver  
(Not Included)



2 - People  
Recommended

## ASSEMBLY RATING

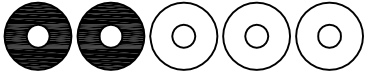

EASY —————> DIFFICULT

The Assembly Rating is a 5-point system showing the level of effort needed to assemble a specific product.



## **CHECK BEFORE STARTING**

### **Are you missing anything?**

Double-check all parts, hardware and accessories listed on Page 6 are accounted for.

### **Check out our Quick Tips!**

We recommend reviewing the pre-assembly handouts. Even experts need a refresher now and then!

### **Should we send any replacements?**

Are there any irregularities or flaws in the parts? We can send replacements!

### **Prep Time!**

Please review the assembly instructions and all diagrams prior to assembling. Arrange parts as recommended on Page 7 and group identical hardware together to make assembling easier.

# PRE ASSEMBLY INTRODUCTION

We understand building ready-to-assemble furniture can be a challenging experience for some. To help avoid confusion, we have provided some helpful tips that may speed up the process.



## Teamwork

ALWAYS have at least two people to help with transporting and assembling the product to avoid potential injury and/or damage.

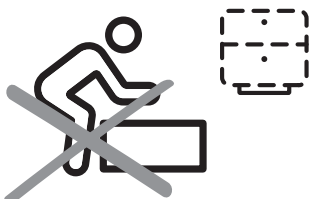

## Suitable Location

Assembling near the area of the intended location is highly recommended.



## Sufficient Space

Make sure you have enough space to move around during the assembly.



## Avoid Scratches

Use cardboard, blankets or a carpeted area while assembling furniture to prevent scratches.



## Flat Surface

Make sure the furniture rests on a flat and level surface with each leg evenly touching the floor.

# ASSEMBLY AND CARE ADVICE



**FAILURE TO FOLLOW THE GUIDELINES BELOW MAY RESULT IN INJURY AND/OR PROPERTY DAMAGE.**



Position each part correctly and insert screws or bolts into their respective holes.



Turn clockwise to tighten and only tighten when step is completed or when instructed to do so.



Use the appropriate hand tools or power tools for assembly. Select steps, such as tightening screws and/or bolts, may require hand tools to avoid causing damage during assembly.



Save the instructions and store any supplied tools for later maintenance.



After two weeks, check and tighten any loose hardware and repeat again every six months thereafter.

**IT IS THE USER'S RESPONSIBILITY TO MAINTAIN THE FURNITURE. THE HARDWARE MAY LOOSEN OVER TIME AND MAY CAUSE THE FURNITURE TO BE WOBBLY AND UNABLE TO SUPPORT ITS INTENDED WEIGHT CAPACITY. THIS MAY LEAD TO COLLAPSE AND MAY CAUSE SERIOUS INJURY.**

# BED



- Please keep instructions for future reference.
- Check the quantity and irregularity of parts and hardware before you start.

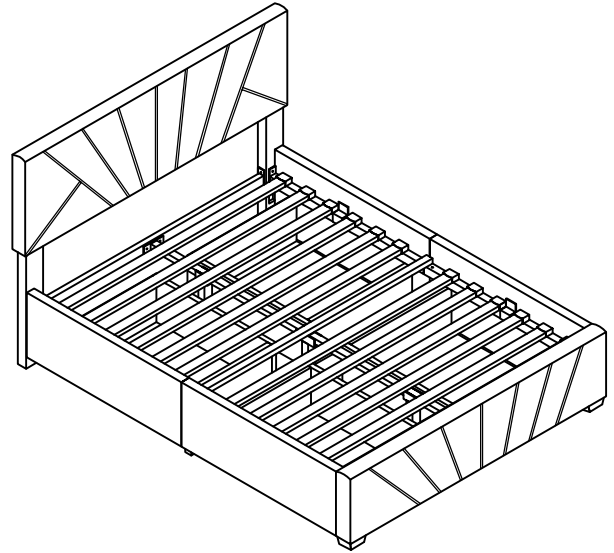

## PARTS

#1 1pc

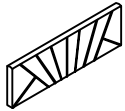

Headboard

#2 2pcs

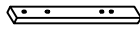

Headboard Leg (L & R)

#3 1pcs

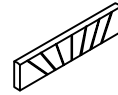

Footboard

#4 2pcs

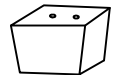

Footboard Leg

#5 1pc

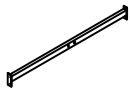

Headboard Leg Support

#6 2pcs

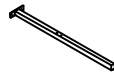

Center Support Rail

#7 4pcs



Side Rail

#8 4pcs



Side Rail Support

#9 12pcs



Bed Slat

#10 4pcs



Drawer side panel (R)

#11 4pcs



Drawer side panel (L)

#12 4pcs



Drawer back panel

#13 4pcs



Drawer front panel

#14 4pcs

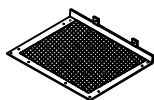

Drawer bottom panel

# BED



- Please keep instructions for future reference.
- Check the quantity and irregularity of parts and hardware before you start.

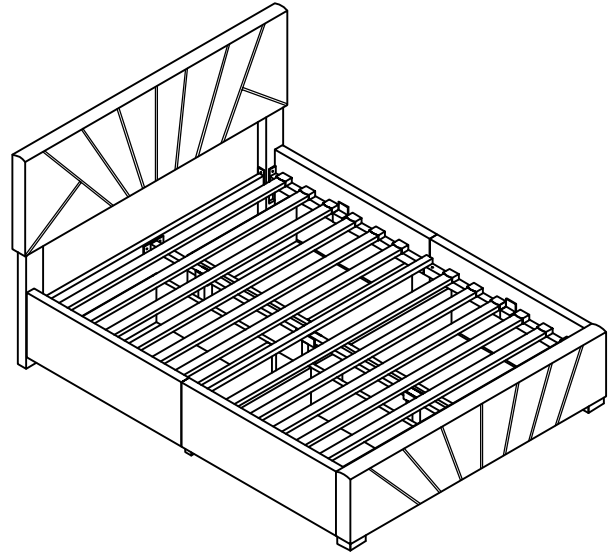

## HARDWARE

#A 22pcs



Bolt  $\frac{5}{16}$ " x 30mm

#B 31pcs



Lock Washer

#C 31pcs



Flat Washer

#D 3pcs x2



Nut

#E 32pcs



Screw

#F 1pc

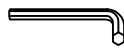

Allen wrench M5

#G 2pcs



Center Support Leg A

#H 24pc



End Cap

#I 16pcs



Wheel

#J 24pcs



Screw 25mm

#K 2pcs



Side Rail Support Leg

#L 1pc



Center Support Leg B

#M 8pcs



Toggle clip

#N 9pcs



Bolt  $\frac{5}{16}$ " x 50mm

#O 1pc

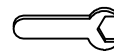

Wrench

#P 4pcs



Metal Bracket

#Q 4pcs



Screw 40mm

# ASSEMBLY INSTRUCTIONS

## 1

- Part #1 x1pc
- Part #2 x2pcs(L/R)
- Hardware #N x 2pcs
- Hardware #B x 2pcs
- Hardware #C x 2pcs

Attach Headboard Leg (#2) to Headboard (#1) using Bolt (#N) with Washers (#B, C)

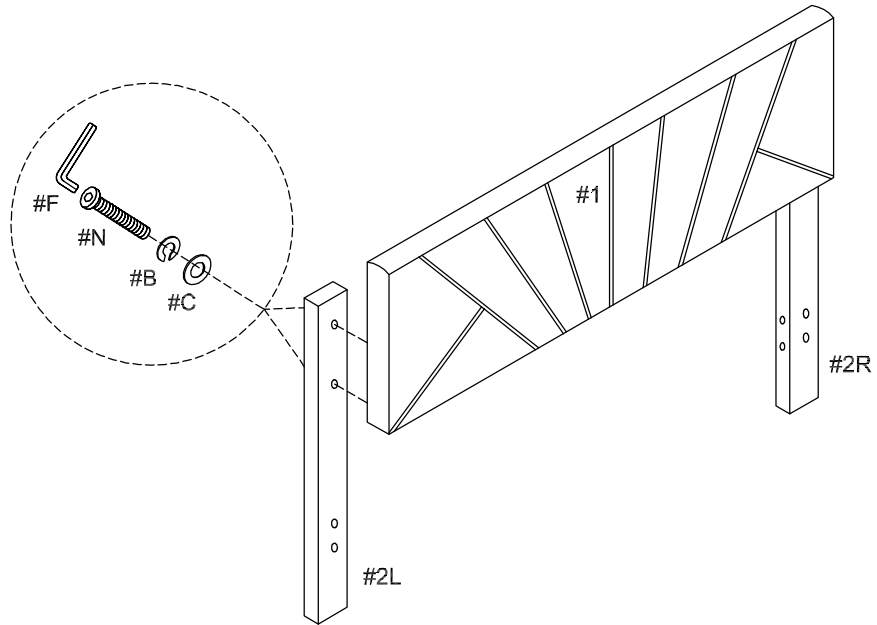

## 2

- Part #5 x1pc
- Hardware #A x 4pcs
- Hardware #B x 4pcs
- Hardware #C x 4pcs

Attach Headboard Leg Support (#5) to Headboard Leg (#2) using Bolt (#A) with Washers (#B, C)

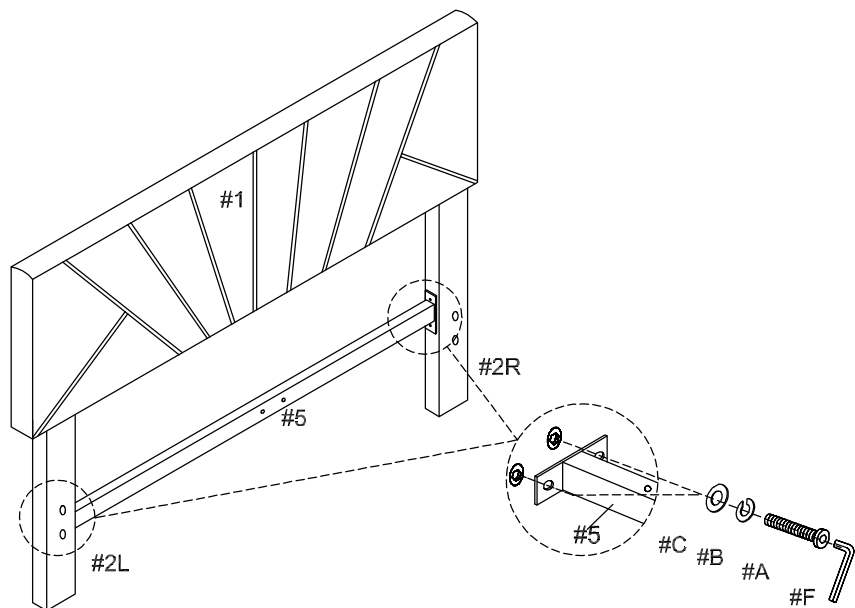

# ASSEMBLY INSTRUCTIONS

## 3

Part #3 x1pc

Part #4 x2pcs

Hardware #Q x 2pcs

Attach Footboard Leg (#4) unto Footboard (#3) and secure using Screw (#Q)

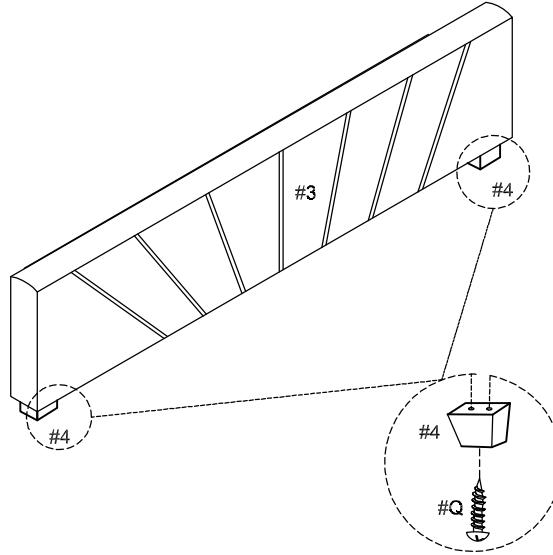

## 4

Part #7 x2pcs

Hardware #N x 2pcs

Hardware #B x 2pcs

Hardware #C x 2pcs

Hardware #D x 2pcs

Hardware #O x 1pc

Hardware #K x 1pc

Attach Support Leg (#K) to Side Rail (#7) and secure using Nut (#D) with Bolt (#N) and Washers (#B, C)

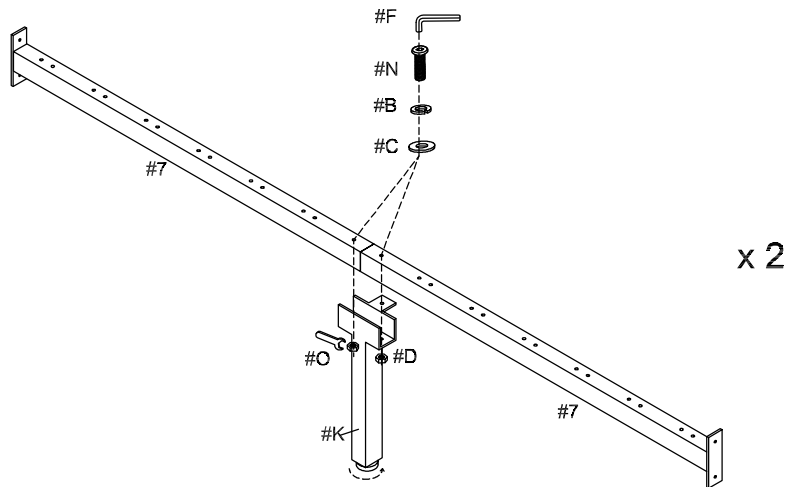

# ASSEMBLY INSTRUCTIONS

## 5

- Part #1 x1pc
- Part #7 x2pc
- Part #3 x1pc
- Hardware #A x 8pcs
- Hardware #B x 8pcs
- Hardware #C x 8pcs

Align and attach Side Rail (#7) to Headboard (#1) and Footboard (#3). Secure using Bolt (#A) with Washers (#B, C)

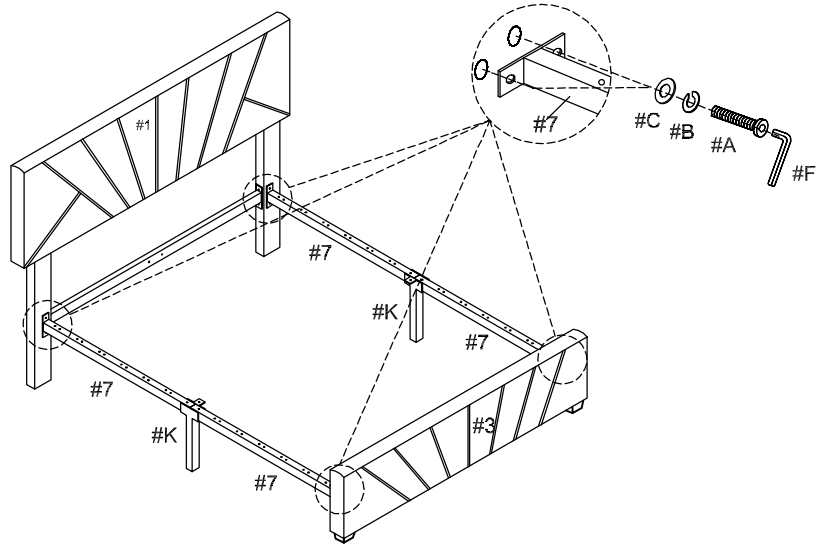

## 6

- Part #6 x2pcs
- Hardware #C x 2pcs
- Hardware #L x 1pc
- Hardware #A x 2pcs
- Hardware #B x 2pcs
- Hardware #C x 2pcs

Attach Support Legs (#G, L) to Center Rail (#6) using Bolt (#A) with Washers (#B, C)

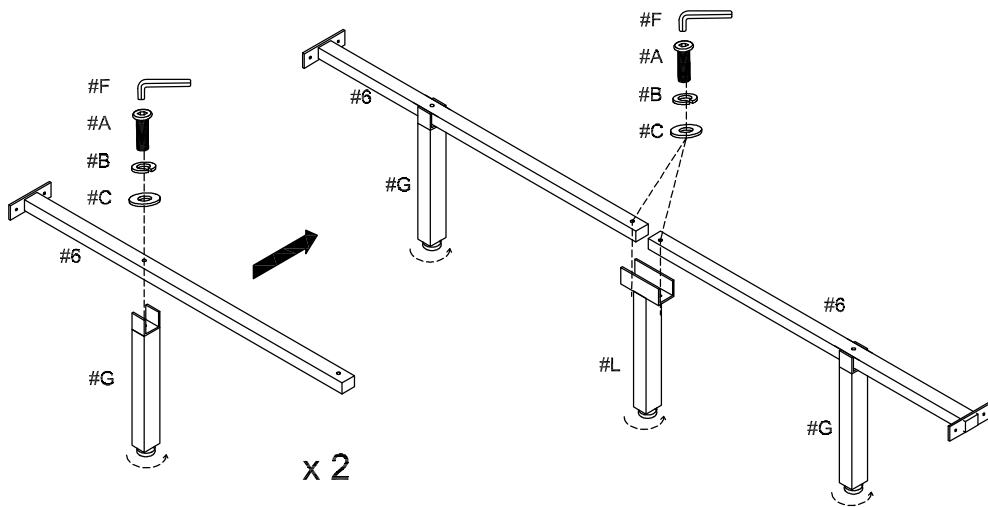

# ASSEMBLY INSTRUCTIONS

## 7

- Part #6 x1pc
- Hardware #A x 4pcs
- Hardware #B x 4pcs
- Hardware #C x 4pcs
- Hardware #D x 2pcs
- Hardware #O x 1pc

Attach Center Rail (#6) to Headboard (#1) and Footboard (#3). Secure using Bolt (#A) with Washers (#B, C) and Nut (#D)

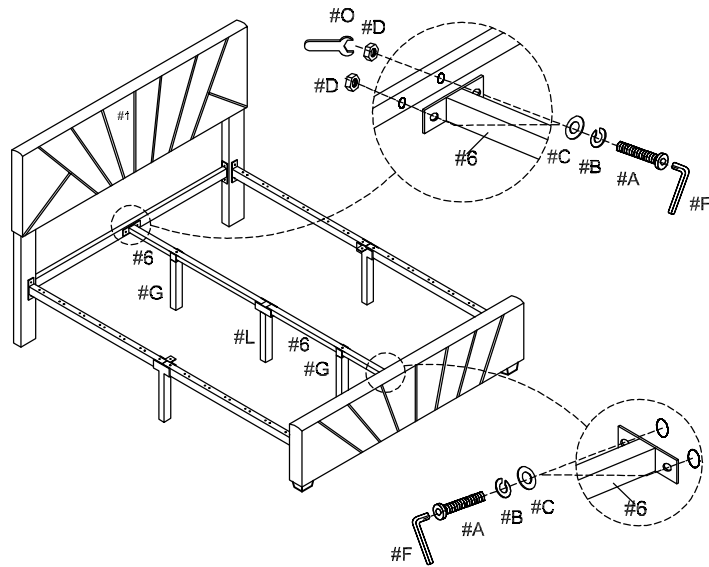

## 8

- Part #8 x1pc
- Hardware #A x 2pcs
- Hardware #B x 3pcs
- Hardware #C x 3pcs
- Hardware #F x 1pc

Align and attach Side Rail (#8) using Bolt (#A) with Washers (B, C)

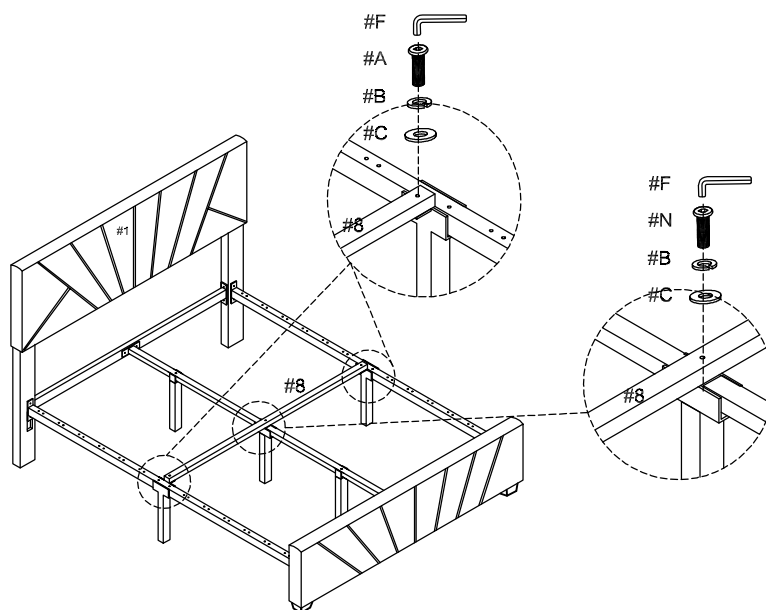

# ASSEMBLY INSTRUCTIONS

## 9

Part #9 x12pcs

Hardware #H x 24pcs

Align and attach  
Bed Slat (#9) using  
End Cap (#H)

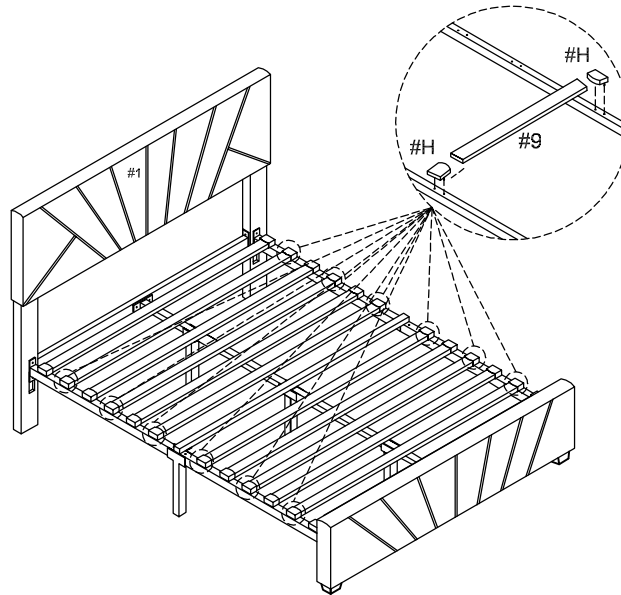

## 10

Part #10 x1pc

Part #11 x1pc

Part #12 x1pc

Align and attach  
Drawer Panels  
(#10, 11, 12) as  
shown

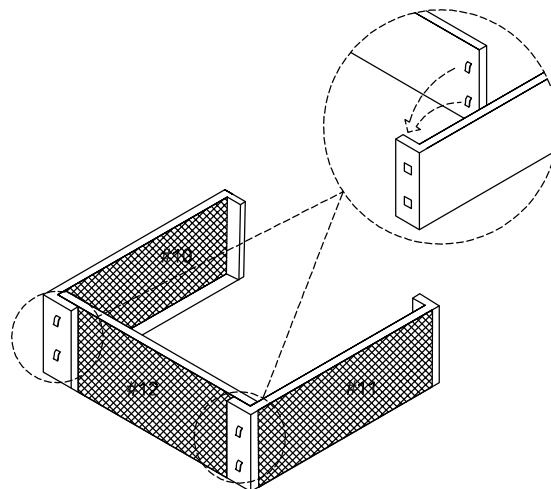

# ASSEMBLY INSTRUCTIONS

## 11

- Part #14 x1pc
- Hardware #E x 8pcs
- Hardware #I x 4pcs

Align and attach Drawer Panel (#14). Then, secure using Screw (#E) with Wheel (#I)

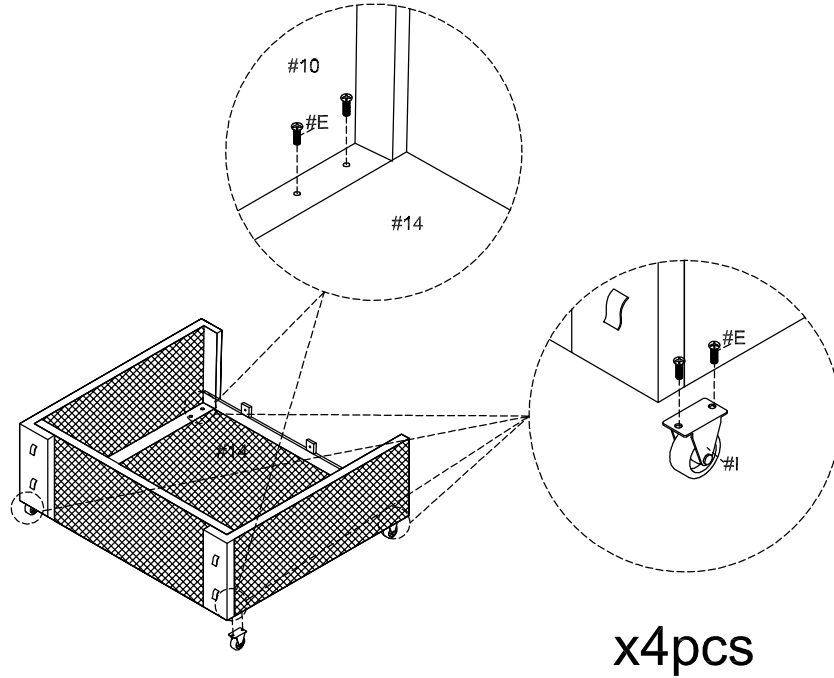

## 12

- Part #13 x1pc
- Hardware #J x 6pcs
- Hardware #M x 2pcs

Align and attach Drawer Panel (#13) by using Screw (#J). Next, attach Toggle Clip (#M)

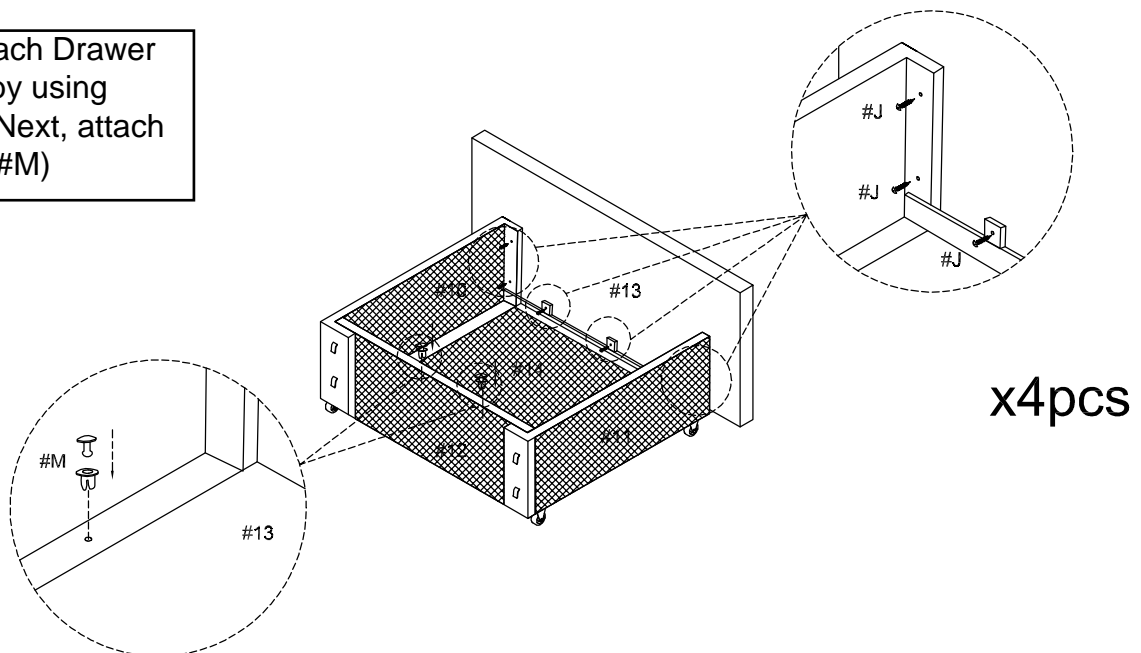

# ASSEMBLY INSTRUCTIONS

## 13

Hardware  x 4pcs

Attach Metal  
Bracket (#P)

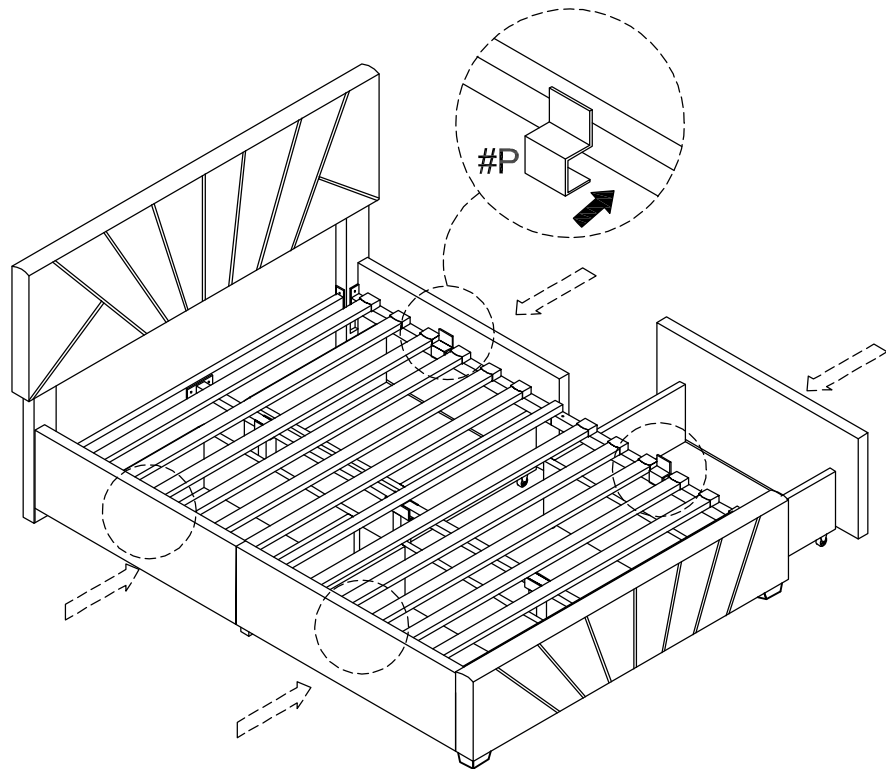

## 14

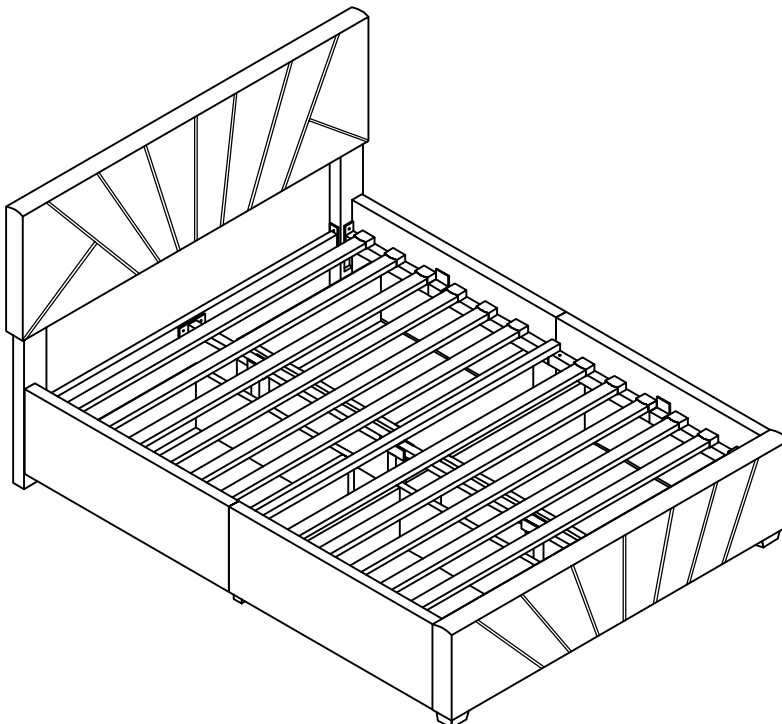

### ASSEMBLY COMPLETED



Please ensure the furniture rests on an even and flat surface. If the product wobbles or feels loose, double-check all bolts and/or screws are properly tightened and secured.



#### Keep this handy!

Please retain this instruction manual and any order-related information for future reference.



#### Lift, don't drag!

To avoid damage to product please always LIFT the product when transporting or adjusting the placement.