

ASSEMBLY INSTRUCTIONS

MODEL #

CM7249-Q/F

Questions?

GIVE US A CALL: 1-888-980-5122
MON-FRI 8:30AM - 5:30PM (PT)

TOOLS REQUIRED



Allen Wrench

(Included)

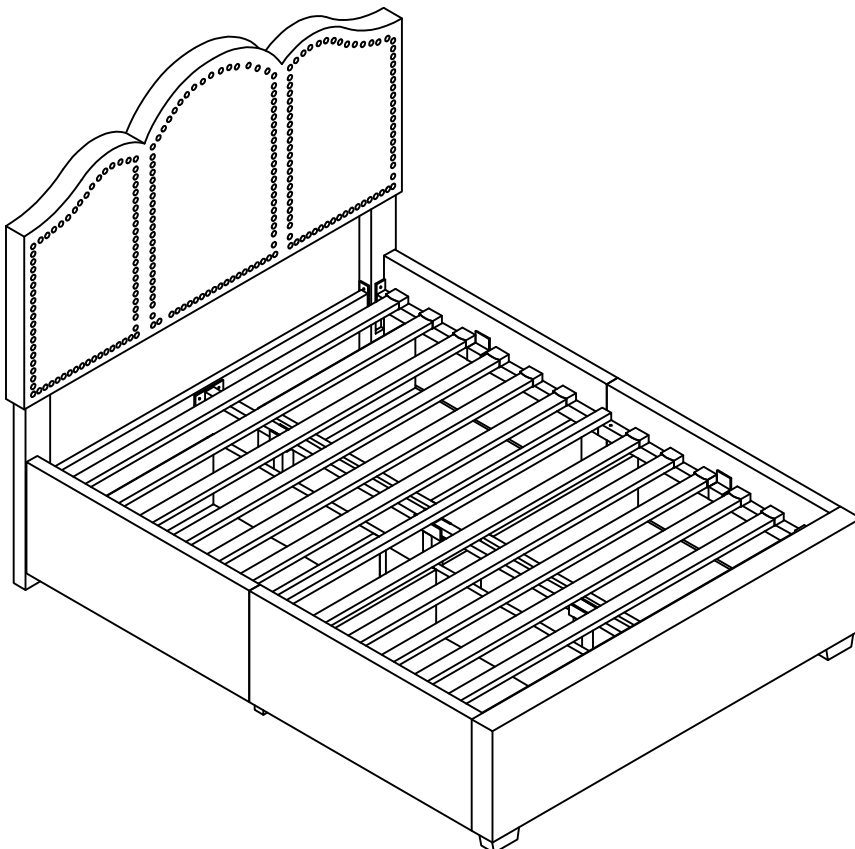

3 - People
Recommended

ASSEMBLY RATING



EASY —————> DIFFICULT

The Assembly Rating is a 5-point system showing the level of effort needed to assemble a specific product.



FOA Intro

Thank you for your purchase!

We hope you enjoy this new addition to your home for many years to come.

Our commitment to providing quality products does not simply end when you purchase our product. We fully stand behind our products from start to finish. Our customer service department is available Monday – Friday 8:30 AM – 5:30 PM Pacific Time and can help with assembly questions as well as, if necessary, replacing damaged or missing parts. To help expedite our service, please have these assembly instructions readily available, along with your order receipt.

 **Consumer Hotline**
Toll-Free 1-888-980-5122

 **Monday to Friday**
8:30AM- 5:30PM (PT)

 **WEBSITE**
www.foagroup.com

 **E-MAIL**
cs.ec@foagroup.com

    foagroup

 FurnitureOfAmerica

CHECK BEFORE STARTING

Are you missing anything?
Double-check all parts, hardware and accessories listed are all accounted for.

Check out our Quick Tips!
We recommend reviewing the pre-assembly handouts. Even experts need a refresher now and then!

Should we send any replacements?
Are there any irregularities or flaws in the parts? We can send replacements!

Prep Time!
Please review the assembly instructions and all diagrams prior to assembling.

PRE ASSEMBLY INTRODUCTION

We understand building ready-to-assemble furniture can be a challenging experience for some. To help avoid confusion, we have provided some helpful tips that may speed up the process.



Teamwork

ALWAYS have at least two people to help with transporting and assembling the product to avoid potential injury and/or damage.



Suitable Location

Assembling near the area of the intended location is highly recommended.



Sufficient Space

Make sure you have enough space to move around during the assembly.



Avoid Scratches

Use cardboard, blankets or a carpeted area while assembling furniture to prevent to prevent scratches and damages.



Flat Surface

Make sure the furniture rests on a flat and level surface with each leg evenly touching the floor.

ASSEMBLY AND CARE ADVICE



FAILURE TO FOLLOW THE GUIDELINES BELOW MAY RESULT IN INJURY AND/OR PROPERTY DAMAGE.



Position each part correctly and insert screws or bolts into their respective holes.



Turn clockwise to tighten and only tighten when step is completed or when instructed to do so.



Use the appropriate hand tools or power tools for assembly. Select steps, such as tightening screws and/or bolts, may require hand tools to avoid causing damage during assembly.



Save the instructions and store any supplied tools for later maintenance.



After two weeks, check and tighten any loose hardware and repeat again every six months thereafter.

IT IS THE USER'S RESPONSIBILITY TO MAINTAIN THE FURNITURE. THE HARDWARE MAY LOOSEN OVER TIME AND MAY CAUSE THE FURNITURE TO BE WOBBLY AND UNABLE TO SUPPORT ITS INTENDED WEIGHT CAPACITY. THIS MAY LEAD TO COLLAPSE AND MAY CAUSE SERIOUS INJURY.

QUEEN / FULL BED

CM7249-Q/F



- Please keep instructions for future reference.
- Check the quantity and irregularity of parts and hardware before you start.

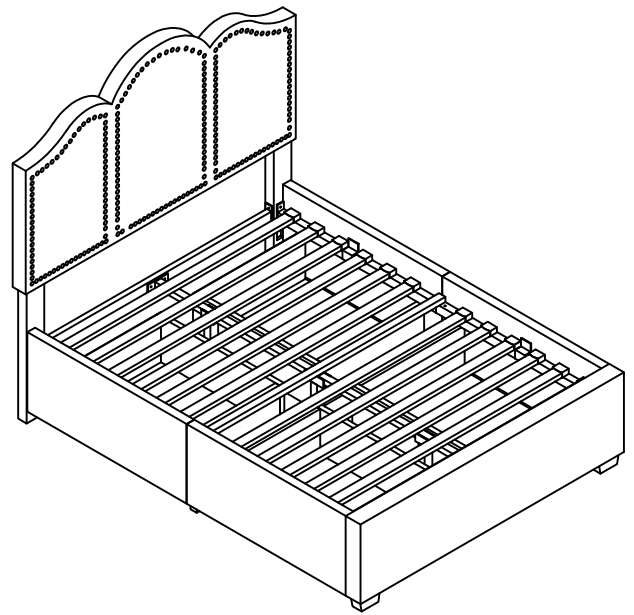

PARTS

#1 1pc

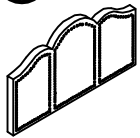

Headboard Panel

#2 2pcs

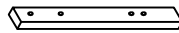

Headboard Leg (L & R)

#3 1pc

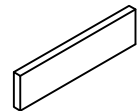

Footboard

#4 2pcs



Footboard Leg

#5 1pc



Headboard Leg Support

#6 2pcs



Center Support Rail

#7 4pcs

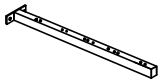

Side Rail

#8 1pc



Side Rail Support

#9 12pcs

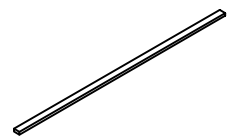

Bed Slat

#10 4pcs

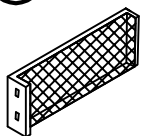

Drawer side panel (R)

#11 4pcs

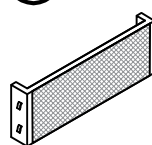

Drawer side panel (L)

#12 4pcs

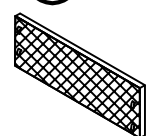

Drawer back panel

QUEEN / FULL BED

CM7249-Q/F



- Please keep instructions for future reference.
- Check the quantity and irregularity of parts and hardware before you start.

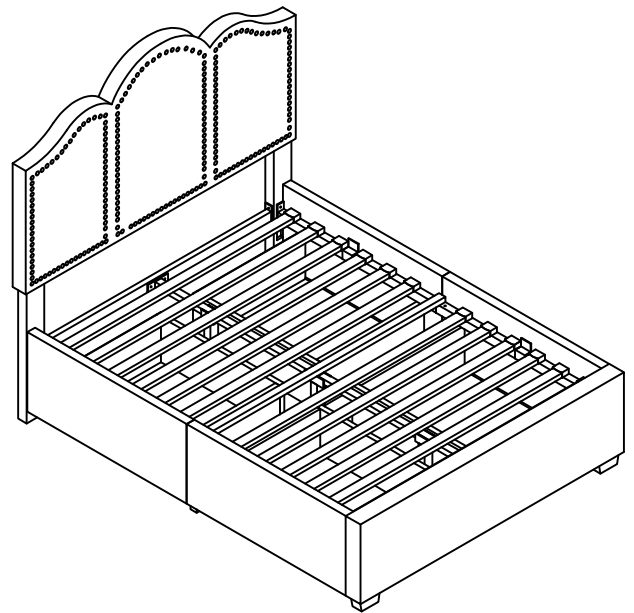

PARTS

#13 4pcs

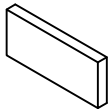

Drawer front panel

#14 4pcs

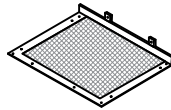

Drawer bottom panel

HARDWARE

#A 22pcs



Bolt Ø8 x 30mm

#B 33pcs



Lock Washer

#C 33pcs



Flat Washer

#D 6pcs



Nut

#E 32pcs



Screw

#F 1pc

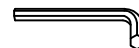

Allen wrench

#G 2pcs



Center Support Leg A

#H 24pcs



End Cap

#I 16pcs



Wheel

QUEEN / FULL BED

CM7249-Q/F



- Please keep instructions for future reference.
- Check the quantity and irregularity of parts and hardware before you start.

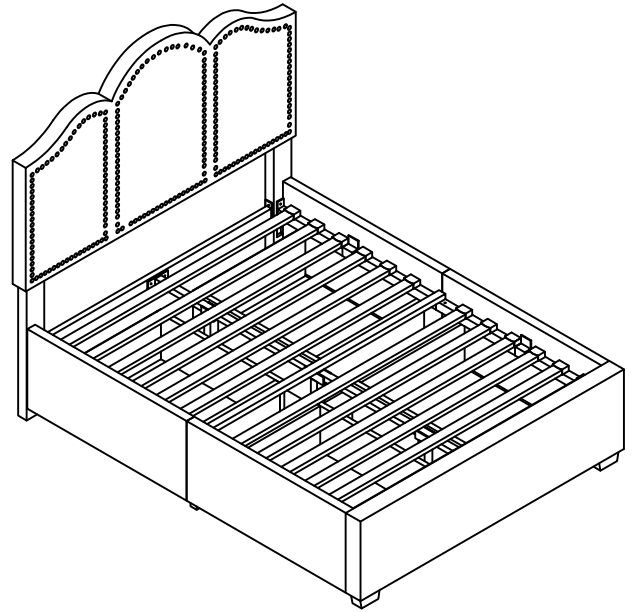

HARDWARE

#J 24pcs



Screw

#K 2pcs



Side Rail Support Leg

#L 1pc



Center Support Leg B

#M 8pcs



Toggle clip

#N 11pcs



Bolt $\frac{5}{16}$ " x 50mm

#O 1pc

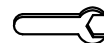

Wrench

#P 4pcs



Metal Bracket

ASSEMBLY INSTRUCTIONS

1

- Part #1 x1pc
- Part #2 x2pcs
- Hardware #B x16pcs
- Hardware #C x16pcs
- Hardware #N x16pcs

Align headboard leg (#2) to the headboard (#1), then secure using bolt (#N) with washers (#B,C).

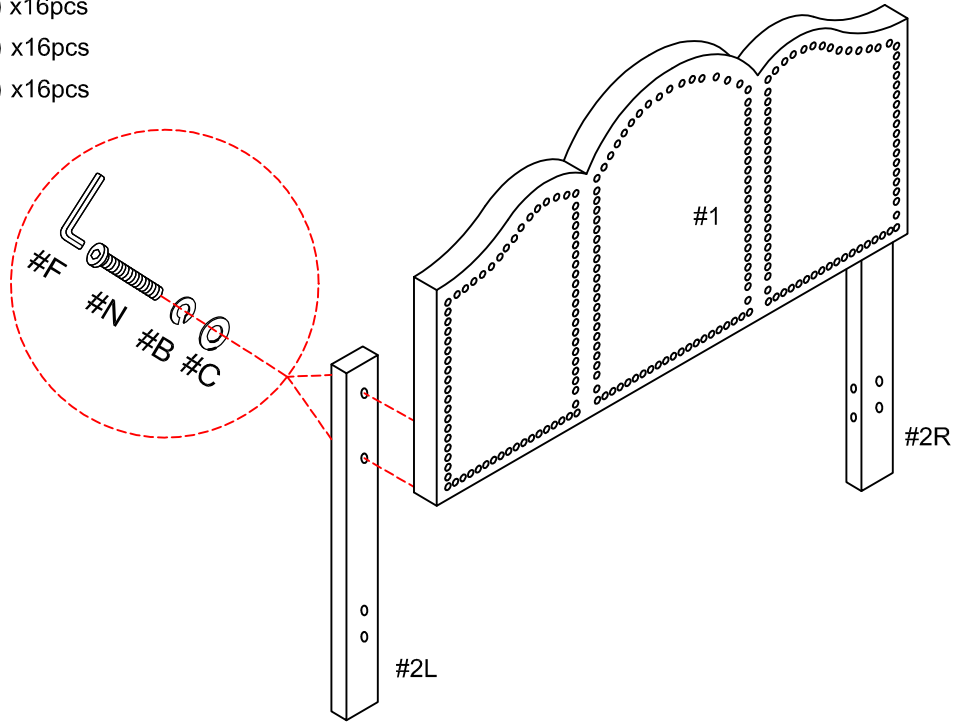

2

- Part #5 x1pc
- Hardware #A x4pcs
- Hardware #B x4pcs
- Hardware #C x4pcs

Secure the Headboard leg support (#5) to the headboard legs (#2) by using bolts (#A) with washers (#B,C).

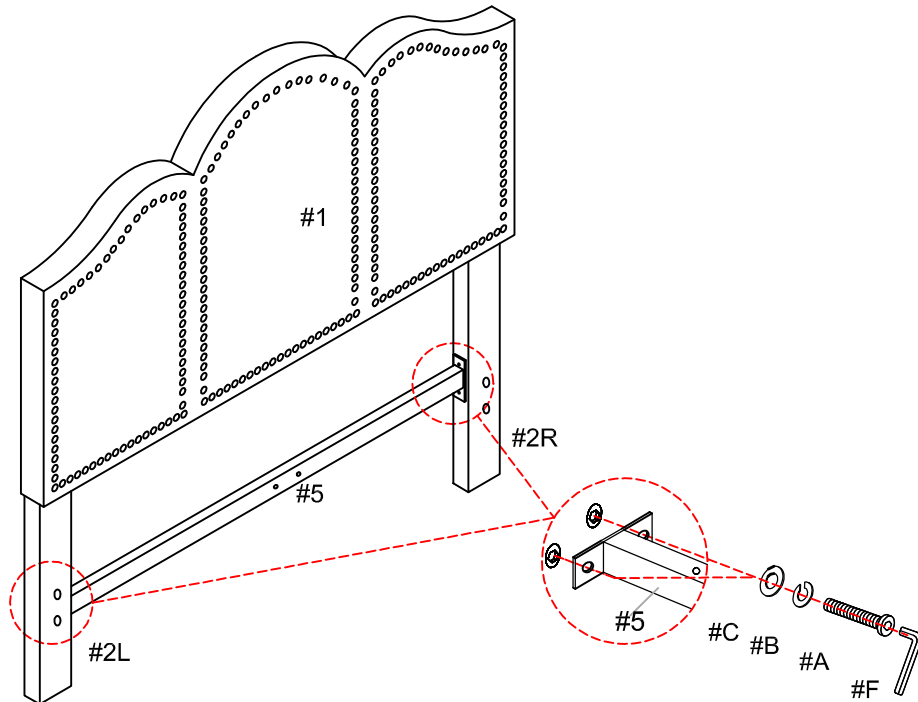

ASSEMBLY INSTRUCTIONS

- 3** Part #3 x1pc
 Part #4 x2pcs
 Hardware #B x2pcs
 Hardware #C x2pcs
 Hardware #N x2pcs

Attach footboard legs (#4) to the footboard (#3) by using bolts (#N) with washers (#B,C).

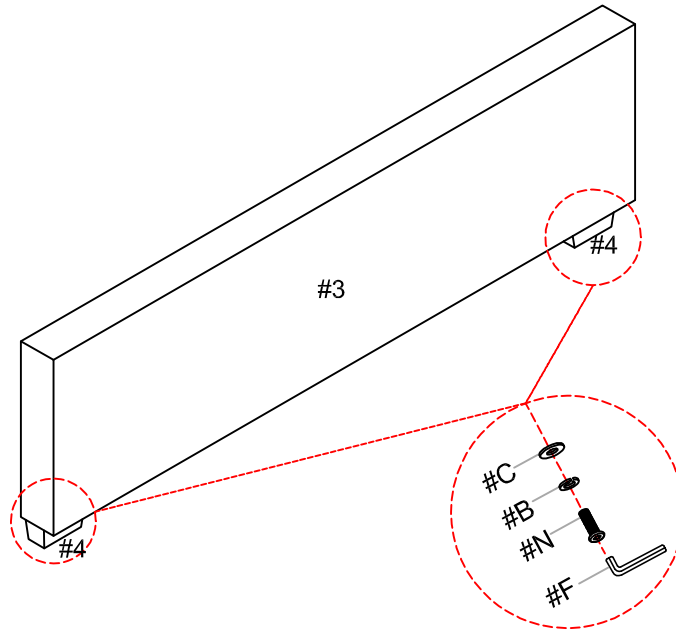

- 4** Part #7 x4pcs
 Hardware #B x4pcs
 Hardware #C x4pcs
 Hardware #D x4pcs
 Hardware #K x2pcs
 Hardware #N x4pcs

Align side rail support leg (#K) to the center of the side rails (#7), then secure using bolts (#N) with washers (#B,C) and nuts (#D).

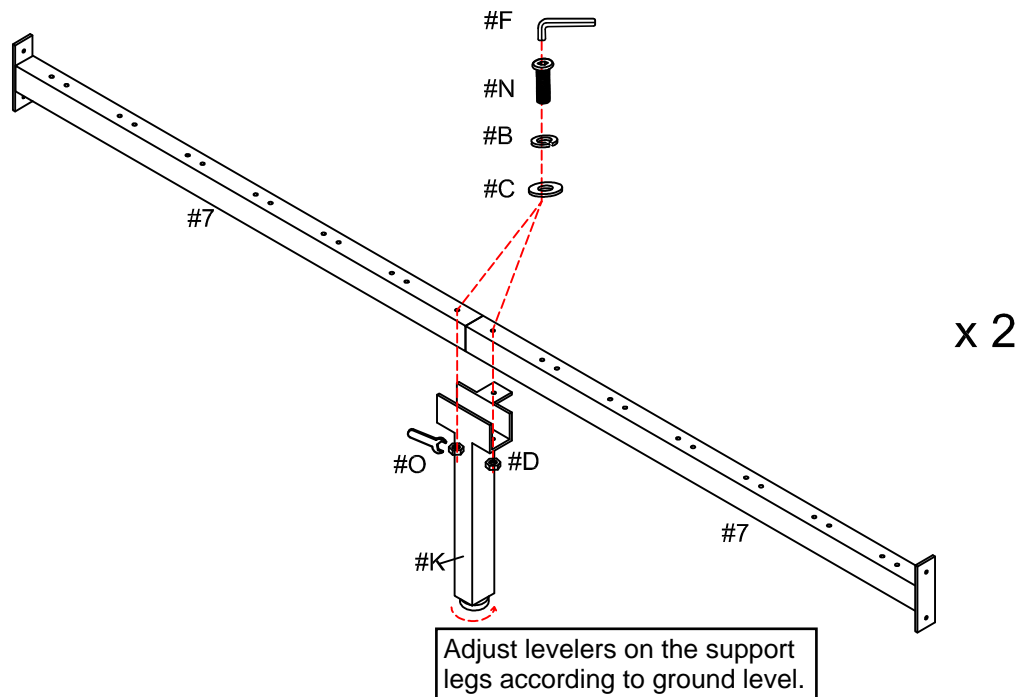

ASSEMBLY INSTRUCTIONS

5

- Hardware #A x8pcs
- Hardware #B x8pcs
- Hardware #C x8pcs

Attach the side rails to the headboard (#1) and footboard (#3), secure using bolts (#A) with washers (#B,C).

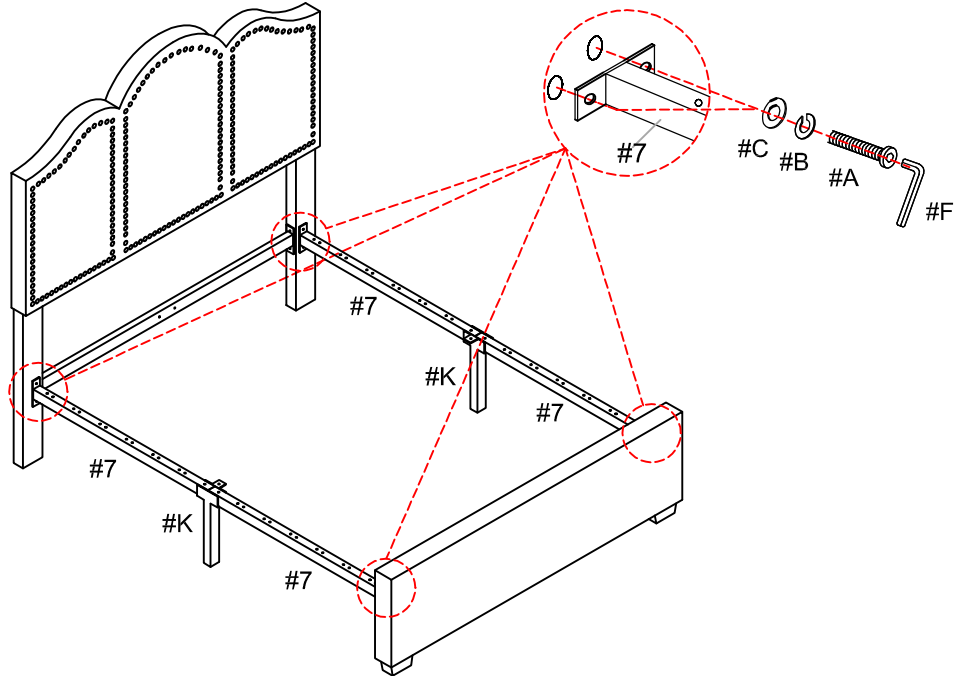

6

- Part #6 x4pcs
- Hardware #A x4pcs
- Hardware #B x4pcs
- Hardware #C x4pcs
- Hardware #G x2pcs
- Hardware #L x1pc

Align the center support leg (#L) to both center support rails (#6) and secure using bolts (#A) with washers (#B,C). Attach center support legs A (#G) to the ends of the center support rails (#6) and secure using the same bolts and washers.

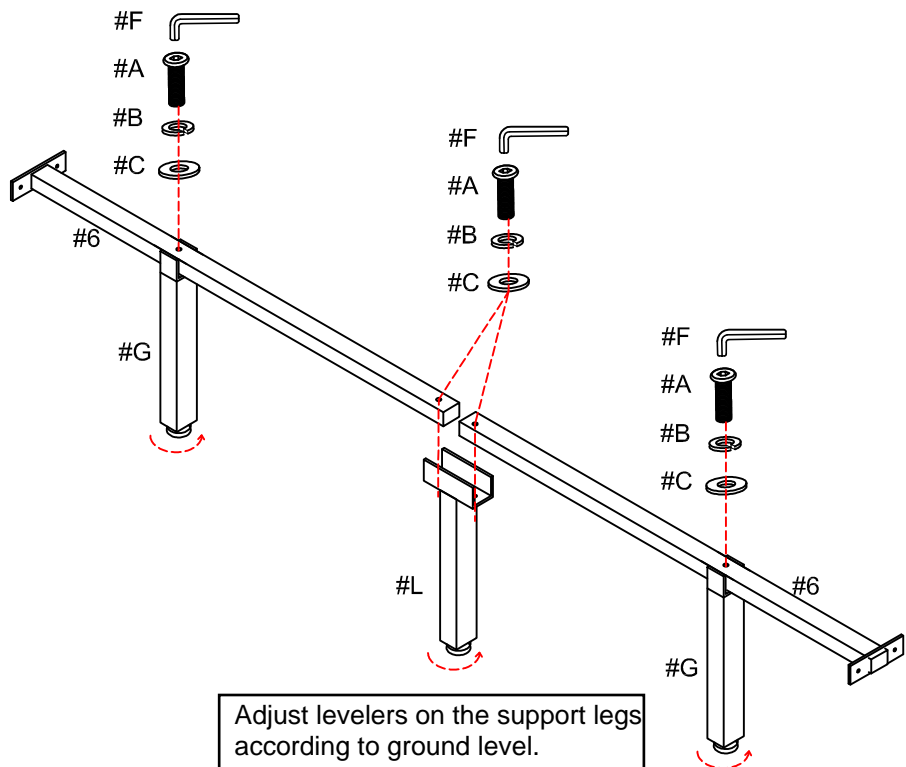

Adjust levelers on the support legs according to ground level.

ASSEMBLY INSTRUCTIONS

7

- Hardware #A x4pcs
- Hardware #B x4pcs
- Hardware #C x4pcs
- Hardware #D x2pcs

Attach the center support rail (#6) to the headboard leg support (#5) and the footboard (#3) by using bolts (#A) with washers (#B,C) and nuts (#D).

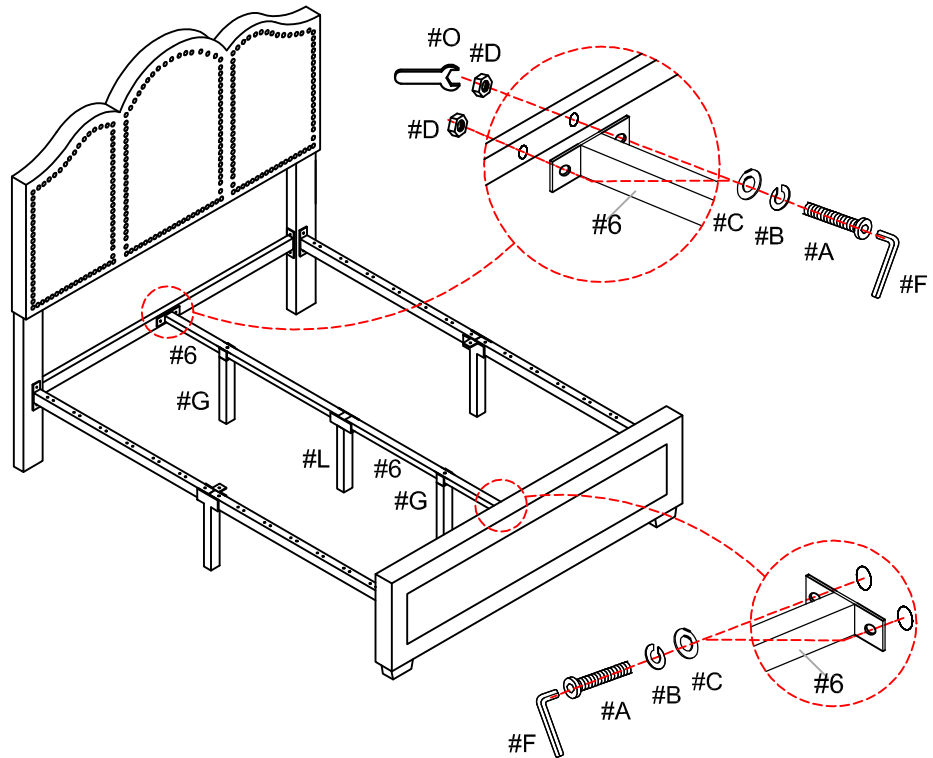

8

- Part #8 x1pc
- Hardware #A x2pcs
- Hardware #B x3pcs
- Hardware #C x3pcs
- Hardware #N x1pc

Secure side rail support (#8) onto the side rails (#7) by using bolts (#N) with washers (B,C).

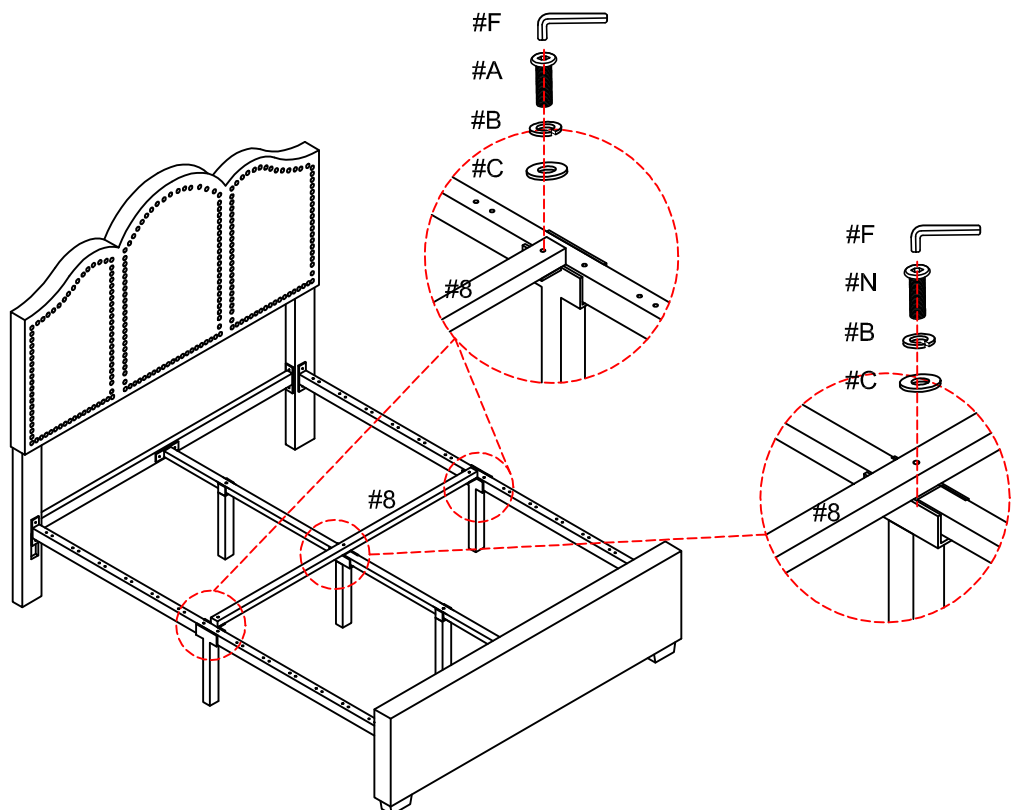

ASSEMBLY INSTRUCTIONS

9

Part #9 x12pcs
Hardware #H x24pcs

Place end caps (#H) into place as marked. Insert bed slats (#9).

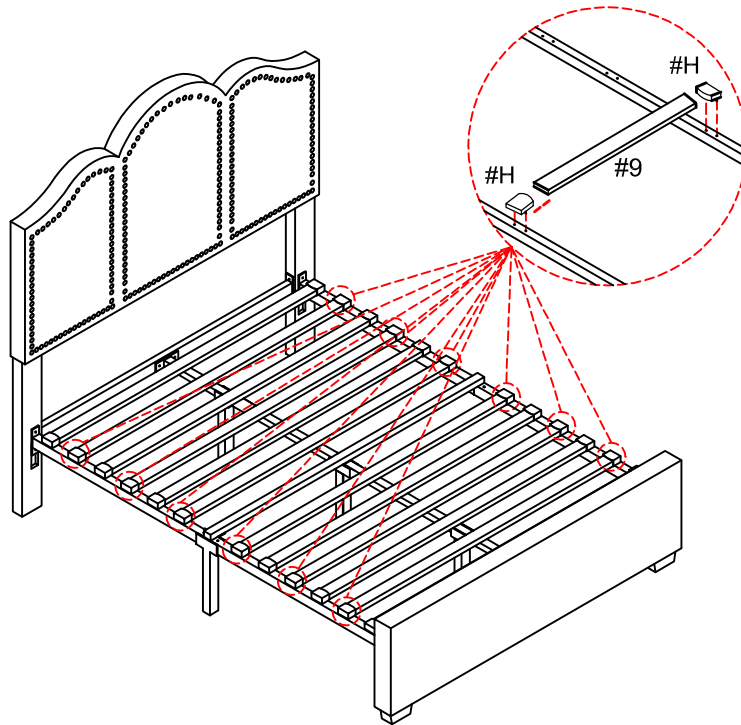

10

Part #10 x 4pcs
Part #11 x 4pcs
Part #12 x 4pcs

Attach the drawer right and left side panels (#10,11) to the drawer back (#12).

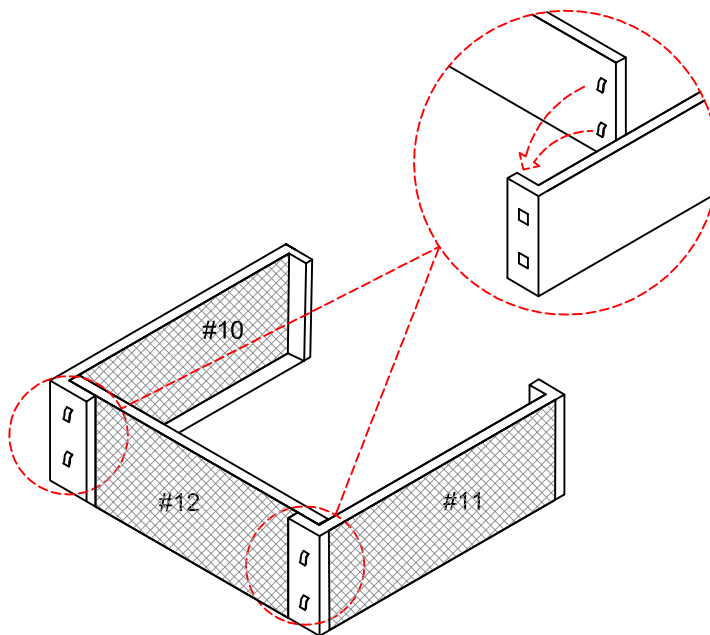

x 4

ASSEMBLY INSTRUCTIONS

11

- Part #14 x 4pcs
- Hardware #E x32pcs
- Hardware #I x16pcs

x 4

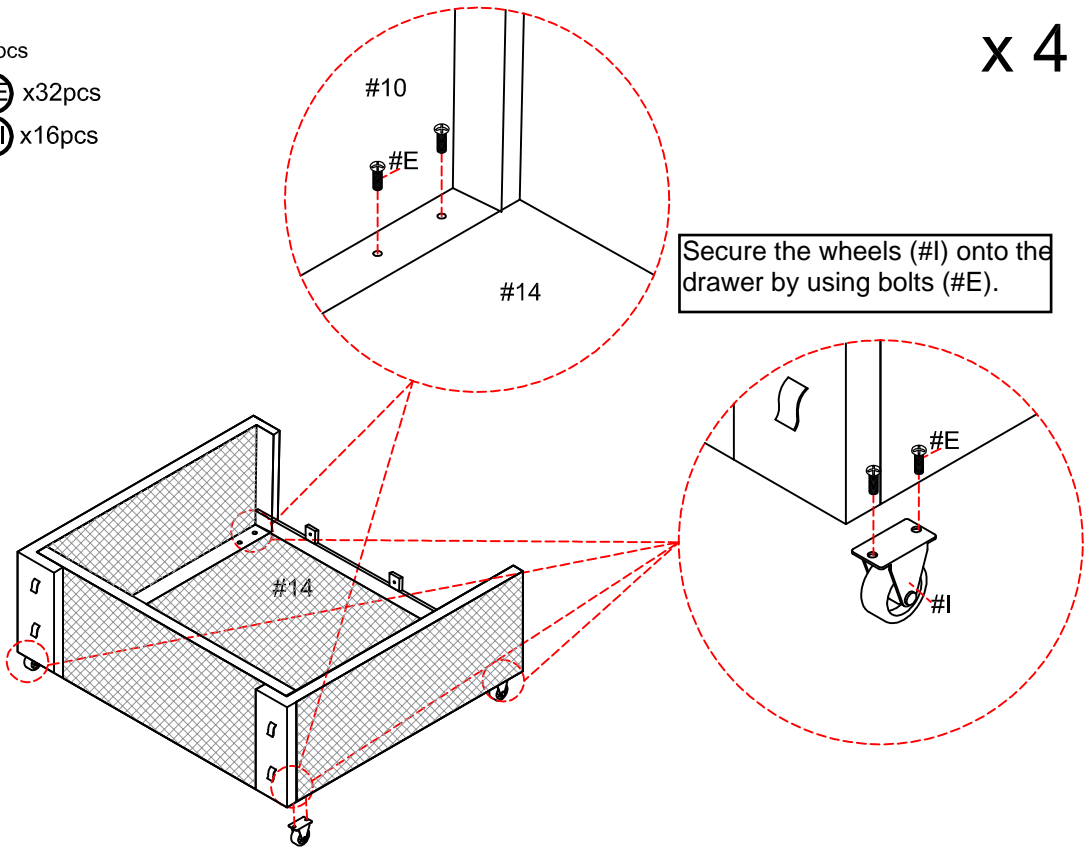

12

- Part #13 x 4pcs
- Hardware #J x24pcs
- Hardware #M x8pcs

Align front drawer panel (#13) to the drawer side panels (#10,11), then secure by using screws (#J). Attach toggle clips (#M) to the back of the drawer as shown.

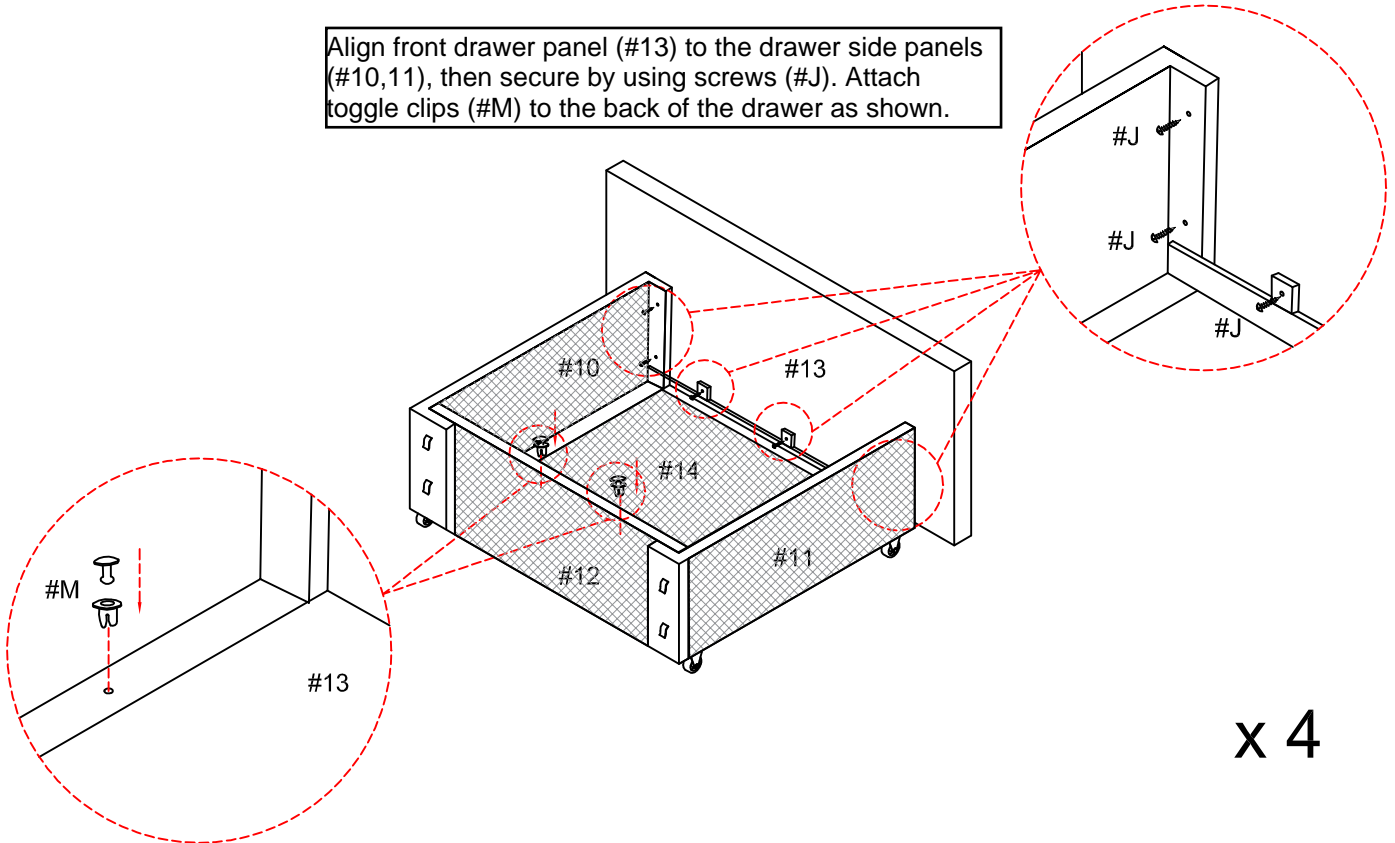

x 4

ASSEMBLY INSTRUCTIONS

13

Hardware  x4pcs

Install all metal bracket (#P) to avoid mattress from drifting sideway.

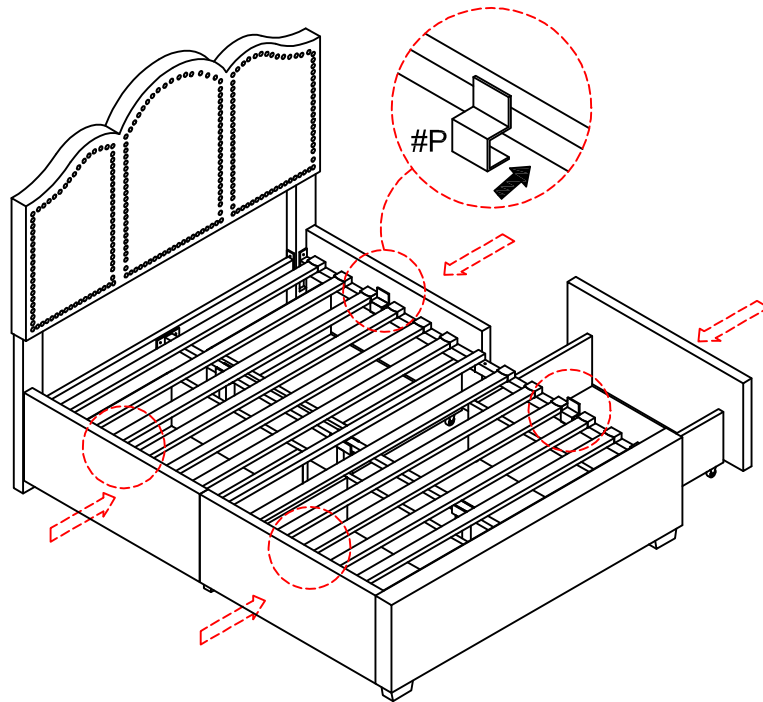

14

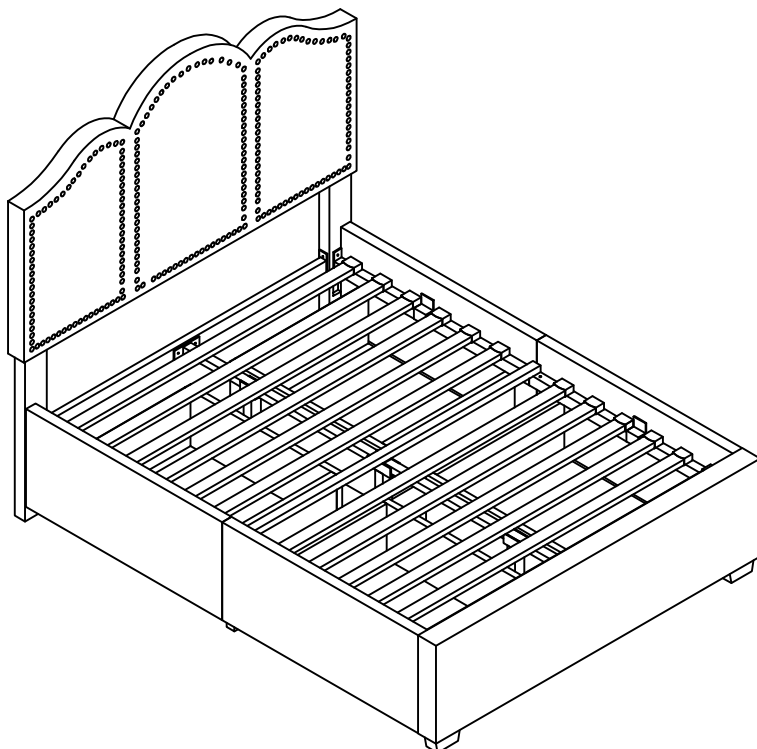

ASSEMBLY COMPLETED



Please ensure the furniture rests on an even and flat surface. If the product wobbles or feels loose, double-check all bolts and/or screws are properly tightened and secured.



Keep this handy!

Please retain this instruction manual and any order-related information for future reference.



Lift, don't drag!

To avoid damage to product please always LIFT the product when transporting or adjusting the placement.