

ASSEMBLY INSTRUCTIONS

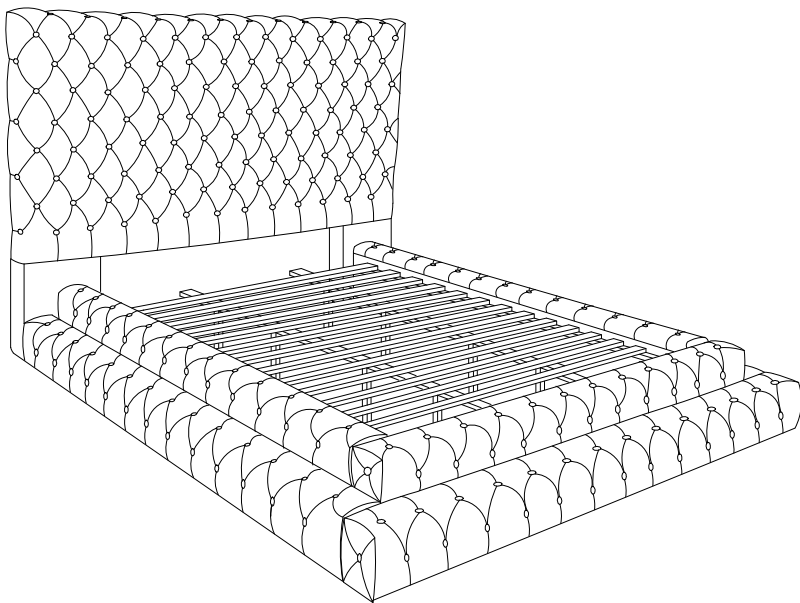

TOOLS REQUIRED



Allen Wrench

(Included)



Phillips
Screwdriver

(Not Included)



2 - People
Recommended

ASSEMBLY RATING



EASY —————> DIFFICULT

The Assembly Rating is a 5-point system showing the level of effort needed to assemble a specific product.



CHECK BEFORE STARTING

Are you missing anything?

Double-check all parts, hardware and accessories listed are all accounted for.

Check out our Quick Tips!

We recommend reviewing the pre-assembly handouts. Even experts need a refresher now and then!

Should we send any replacements?

Are there any irregularities or flaws in the parts? We can send replacements!

Prep Time!

Please review the assembly instructions and all diagrams prior to assembling.

PRE ASSEMBLY INTRODUCTION

We understand building ready-to-assemble furniture can be a challenging experience for some. To help avoid confusion, we have provided some helpful tips that may speed up the process.

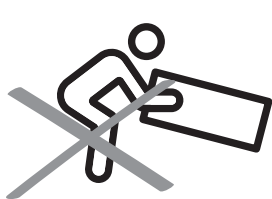

Teamwork

ALWAYS have at least two people to help with transporting and assembling the product to avoid potential injury and/or damage.

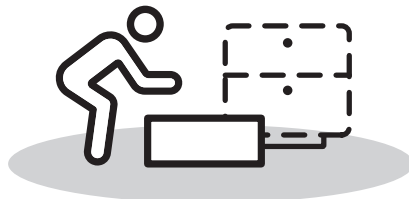
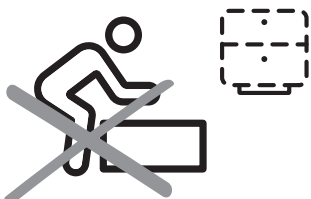

Suitable Location

Assembling near the area of the intended location is highly recommended.



Sufficient Space

Make sure you have enough space to move around during the assembly.

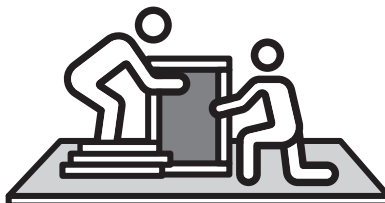

Avoid Scratches

Use cardboard, blankets or a carpeted area while assembling furniture to prevent to prevent scratches and damages.

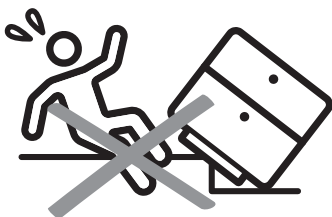

Flat Surface

Make sure the furniture rests on a flat and level surface with each leg evenly touching the floor.

ASSEMBLY AND CARE ADVICE



FAILURE TO FOLLOW THE GUIDELINES BELOW MAY RESULT IN INJURY AND/OR PROPERTY DAMAGE.



Position each part correctly and insert screws or bolts into their respective holes.



Turn clockwise to tighten and only tighten when step is completed or when instructed to do so.



Use the appropriate hand tools or power tools for assembly. Select steps, such as tightening screws and/or bolts, may require hand tools to avoid causing damage during assembly.



Save the instructions and store any supplied tools for later maintenance.



After two weeks, check and tighten any loose hardware and repeat again every six months thereafter.

IT IS THE USER'S RESPONSIBILITY TO MAINTAIN THE FURNITURE. THE HARDWARE MAY LOOSEN OVER TIME AND MAY CAUSE THE FURNITURE TO BE WOBBLY AND UNABLE TO SUPPORT ITS INTENDED WEIGHT CAPACITY. THIS MAY LEAD TO COLLAPSE AND MAY CAUSE SERIOUS INJURY.

BED



- Please keep instructions for future reference.
- Check the quantity and irregularity of parts and hardware before you start.

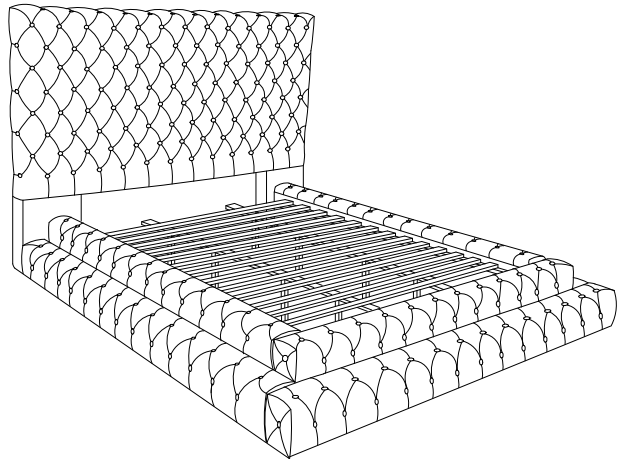

PARTS

#1 1pc

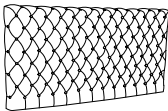

Headboard

#2 2pcs

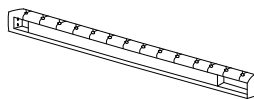

Low Side Rail

#3 2pcs

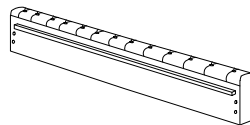

High Side Rail

#4 1pc

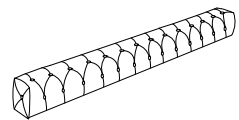

Low Footboard

#5 1pc

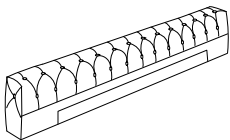

High Footboard

#6 8pcs



Support leg

#7 1set

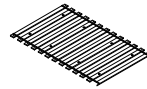

Slat(13pcs)

#8 2pcs



Support Rail

#9 2pcs

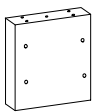

HB Leg (L/R)

#10 18pcs



Leg

HARDWARE

#A 16pcs



Threaded Stud
Ø5/16" x 3-1/4"

#B 16pcs



Bolt Ø5/16" x 1"

#C 32pcs



Lock Washer
Ø5/16"

#D 16pcs



Flat Washer
Ø5/16" x 19mm

#E 16pcs



Flat Washer
Ø5/16" x 22mm

#F 1pc



Allen Wrench 5mm

#G 16pcs



Hex Nut Ø5/16"

#H 44pcs



Screw #8 x 38mm

#I 1pc

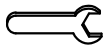

Wrench 12mm

#J 2pcs



Wood tenon
Ø10 x 40mm









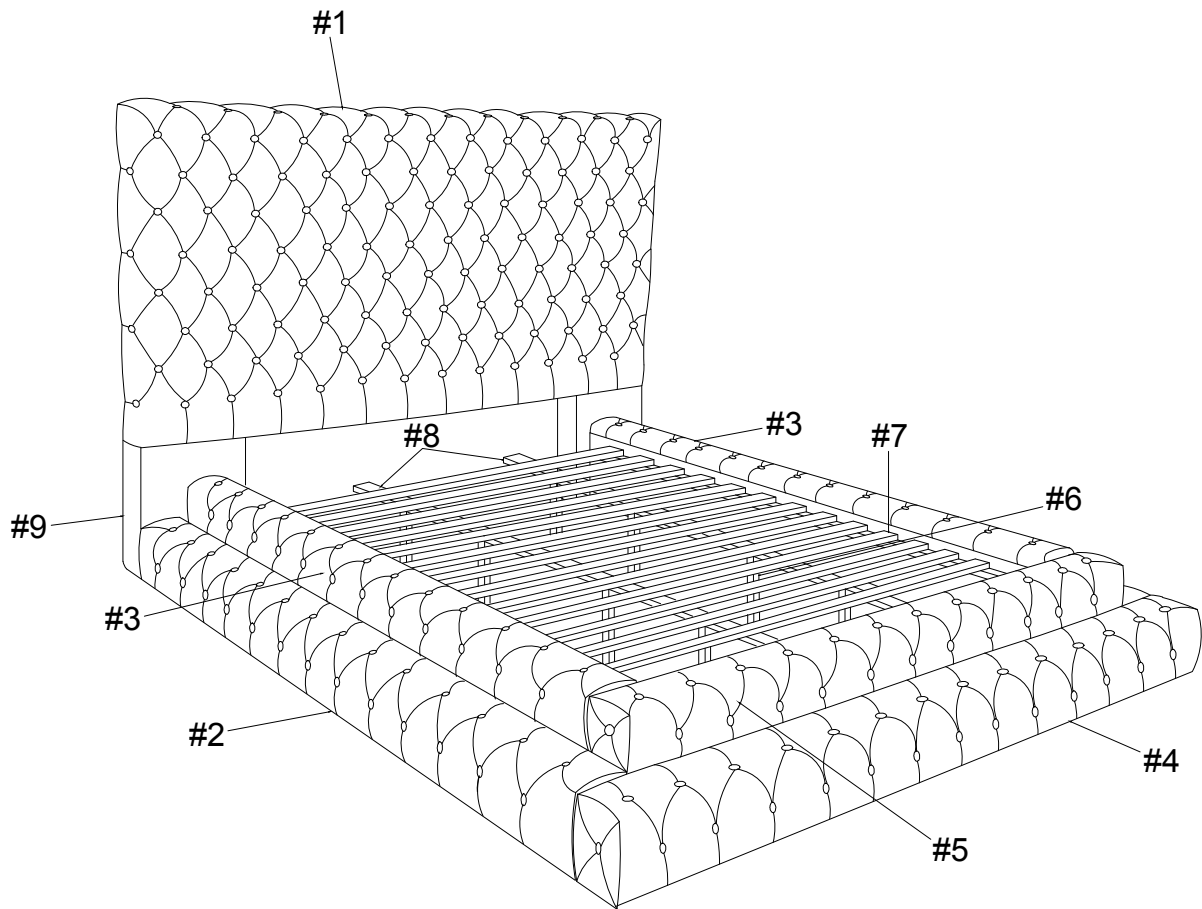

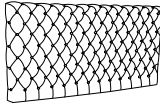



#K 2sets



Connection Strap (L/R)

Exploded View

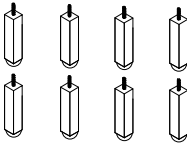
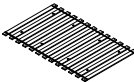

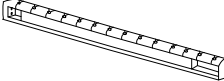
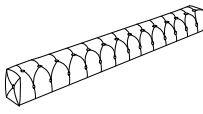
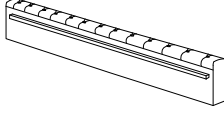
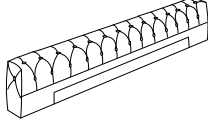
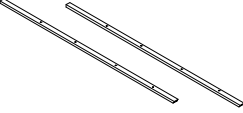
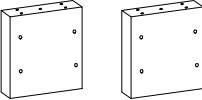
Carton	Disignation	Part		Hardware
1	Headboard	#1		 #A x 16pcs  #B x 16pcs  #C x 32pcs  #D x 16pcs  #E x 16pcs  #F x 1pcs  #G x 16pcs  #H x 44pcs  #I x 1pc  #J x 2pcs  #K x 2sets
	Support leg(8pcs)	#6		
	Slat	#7		
	Leg (18pcs)	#10		
2	Low Side Rail (2pcs)	#2		
	Low Footboard	#4		
3	High Side Rail (2pcs)	#3		
	High Footboard	#5		
	Support Rail(2pcs)	#8		
4	HB Leg (L/R) (2pcs)	#9		

ASSEMBLY INSTRUCTIONS

1

- Part #1 x1pc
- Part #9 x2pcs
- Hardware #A x8pcs
- Hardware #C x8pcs
- Hardware #E x8pcs
- Hardware #G x8pcs
- Hardware #J x2pcs

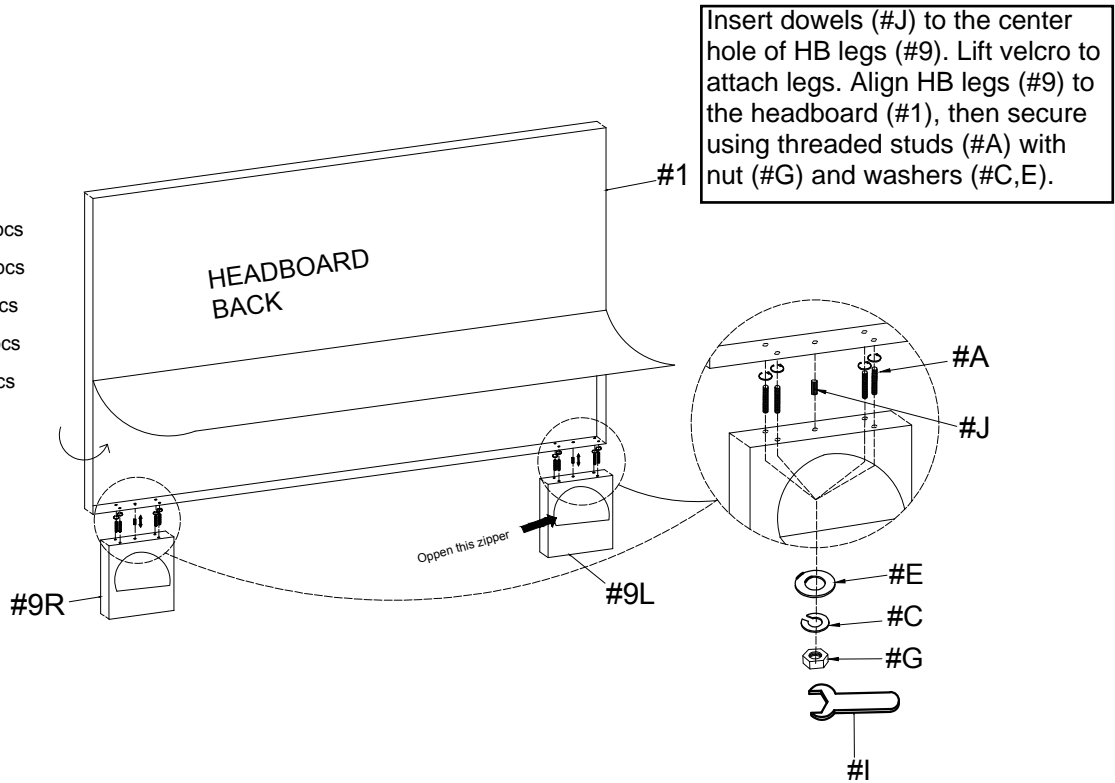

2

- Part #2 x2pcs
- Part #4 x1pc
- Part #10 x9pcs
- Hardware #H x9pcs

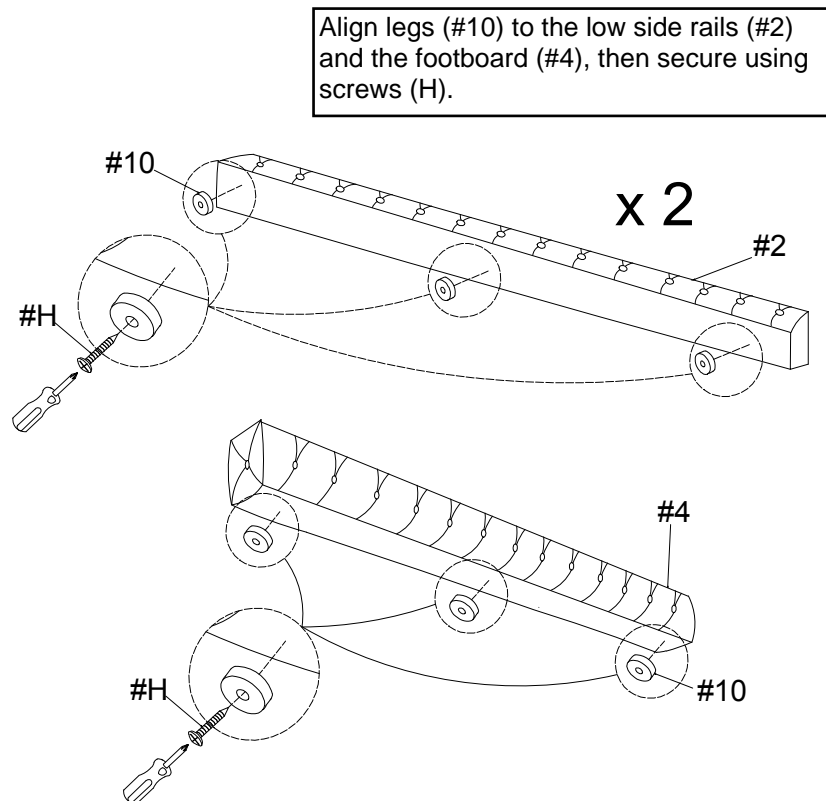

ASSEMBLY INSTRUCTIONS

3

- Part #3 x2pcs
- Part #5 x1pc
- Part #10 x9pcs
- Hardware #H x9pcs

Align legs (#10) to the high side rails (#3) and the footboard (#5).

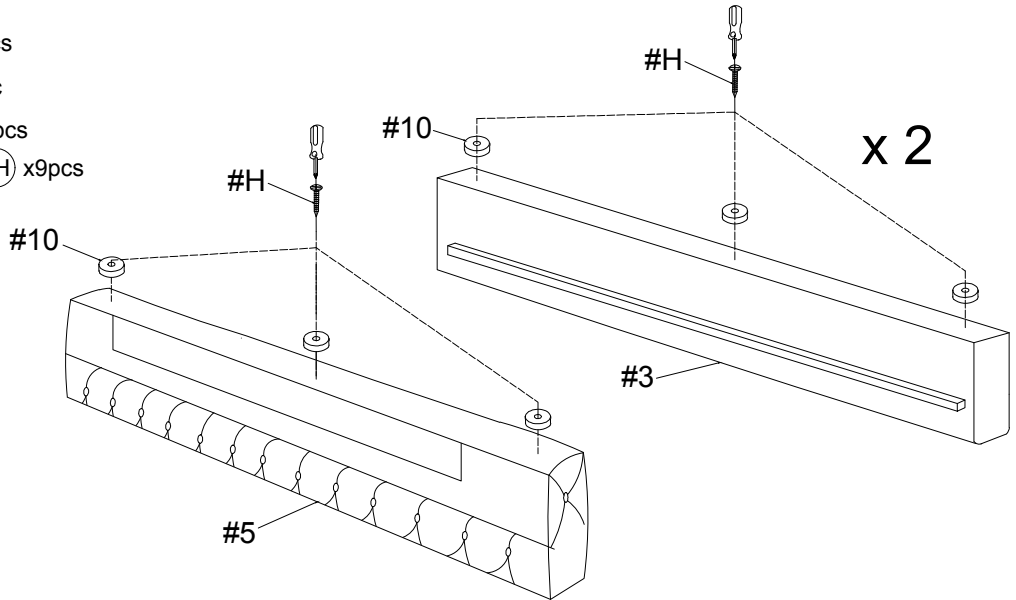

4

- Hardware #A x8pcs
- Hardware #C x8pcs
- Hardware #E x8pcs
- Hardware #G x8pcs

Align low side rails (#2) and foot board (#4) to the headboard (#1), then secure using bolts (#A) with nut (#G) and washers (#C,E).

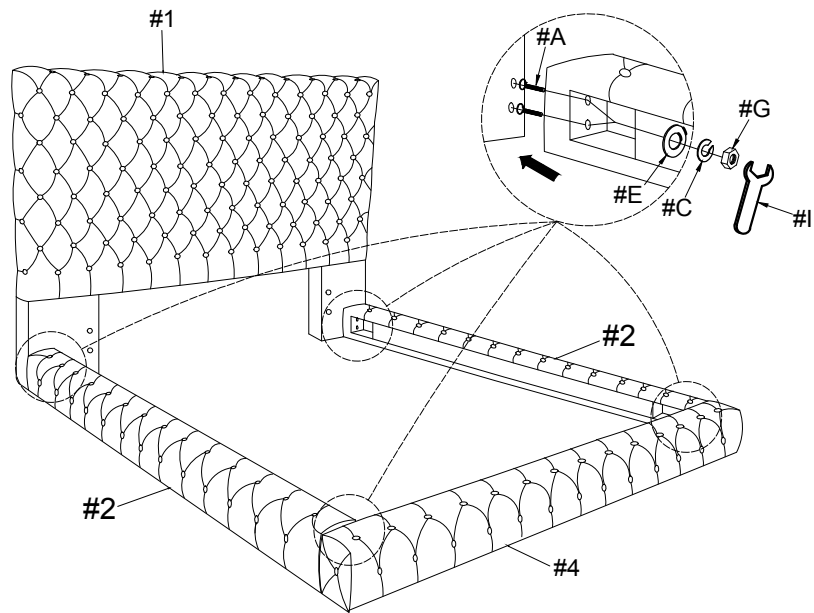

ASSEMBLY INSTRUCTIONS

5

- Part (#3) x2pcs
- Part (#5) x1pc
- Hardware (#B) x16pcs
- Hardware (#C) x16pcs
- Hardware (#D) x16pcs
- Hardware (#K) x2sets

Attach high side rails (#3) to the headboard (#1) and attach to the footboard (#3), then secure by using connection straps (#K) with bolts (#B) with washers (#C,D).

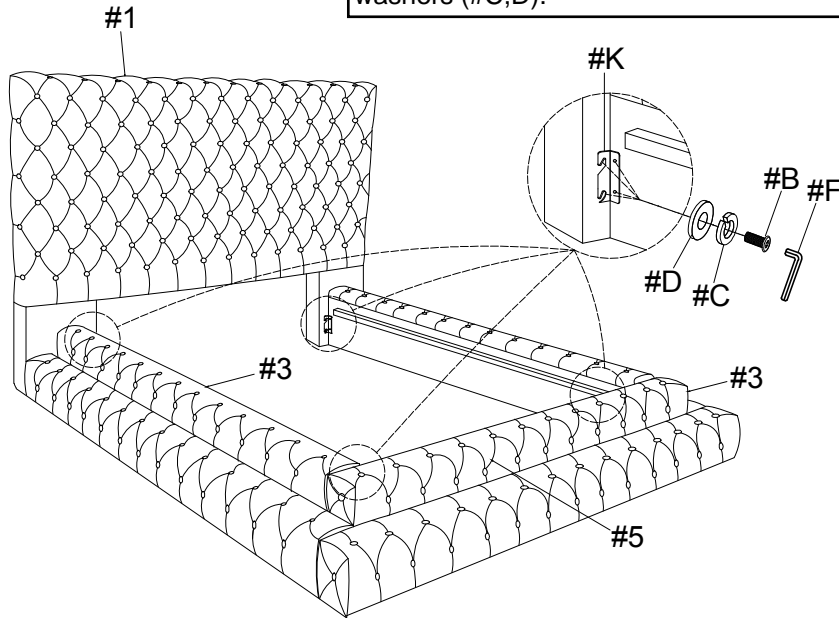

6

- Part (#6) x8pcs
- Part (#7) x1set
- Part (#8) x2pcs

Align the support rails (#8) to the slats (#7). Then secure by inserting support legs (#6).

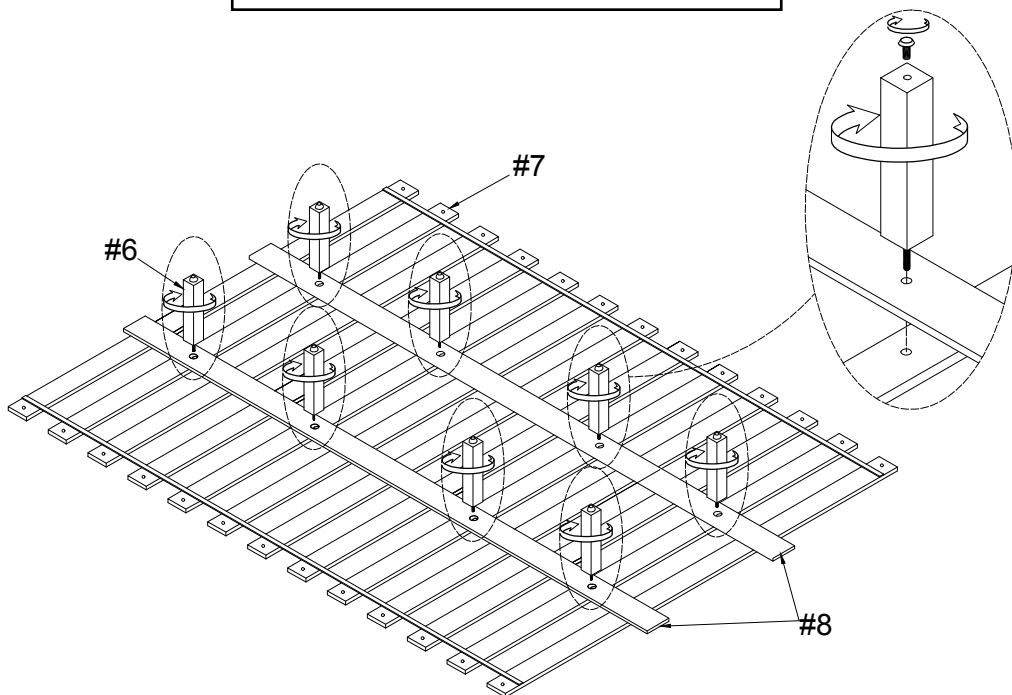

ASSEMBLY INSTRUCTIONS

7

Hardware #H x26pcs

Align the slats (#7) to the side rails (#3), then secure using screws (#H).

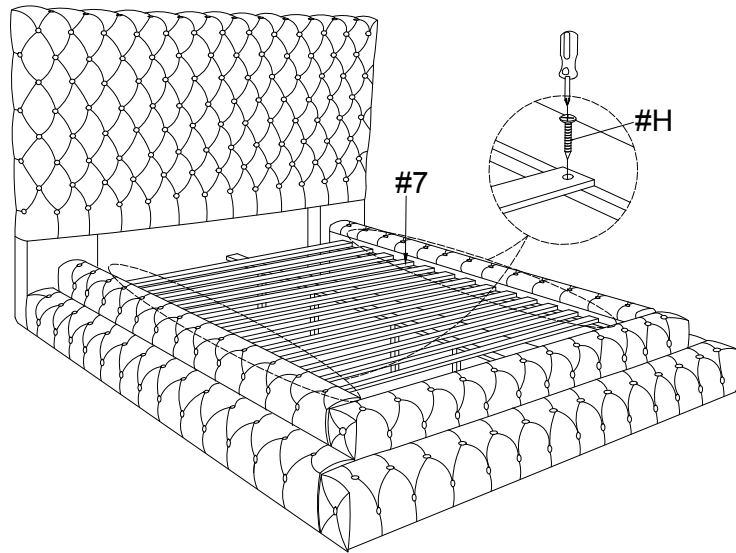

8

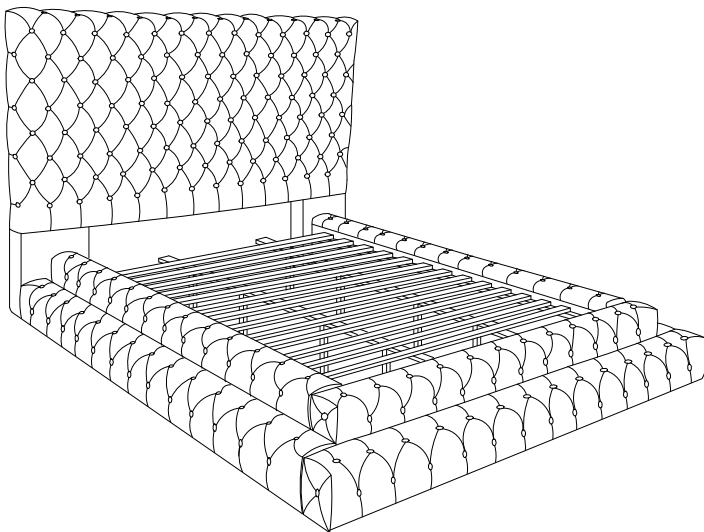

ASSEMBLY COMPLETED



Please ensure the furniture rests on an even and flat surface. If the product wobbles or feels loose, double-check all bolts and/or screws are properly tightened and secured.

✓ **Keep this handy!**

Please retain this instruction manual and any order-related information for future reference.

✓ **Lift, don't drag!**

To avoid damage to product please always LIFT the product when transporting or adjusting the placement.