

ASSEMBLY INSTRUCTIONS

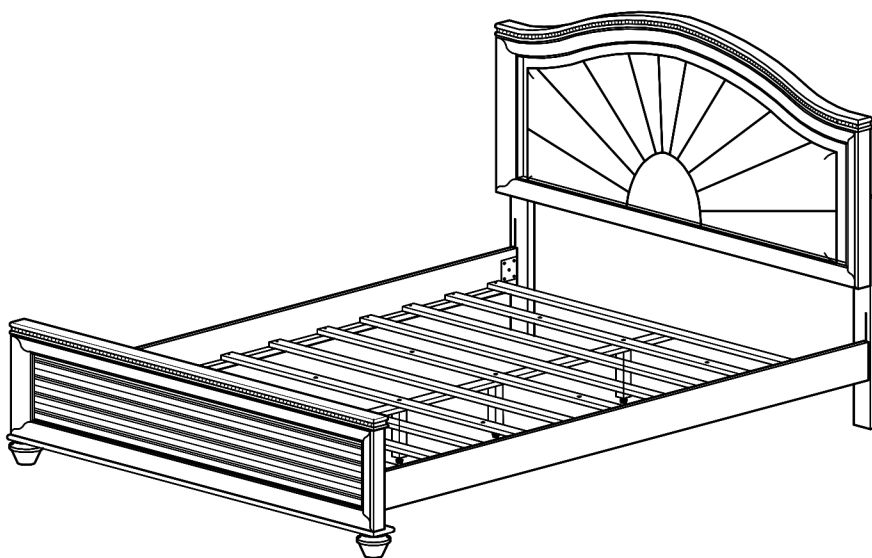

TOOLS REQUIRED

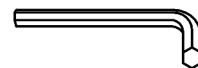

Allen Wrench

(Included)



**Phillips
Screwdriver**

(Not Included)



**3 - People
Recommended**

ASSEMBLY RATING



EASY —————> DIFFICULT

The Assembly Rating is a 5-point system showing the level of effort needed to assemble a specific product.



CHECK BEFORE STARTING

Are you missing anything?

Double-check all parts, hardware and accessories listed on Page 6 are accounted for.

Check out our Quick Tips!

We recommend reviewing the pre-assembly handouts. Even experts need a refresher now and then!

Should we send any replacements?

Are there any irregularities or flaws in the parts? We can send replacements!

Prep Time!

Please review the assembly instructions and all diagrams prior to assembling. Arrange parts as recommended on Page 7 and group identical hardware together to make assembling easier.

PRE ASSEMBLY INTRODUCTION

We understand building ready-to-assemble furniture can be a challenging experience for some. To help avoid confusion, we have provided some helpful tips that may speed up the process.

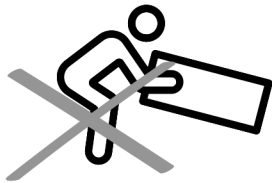

Teamwork

ALWAYS have at least two people to help with transporting and assembling the product to avoid potential injury and/or damage.

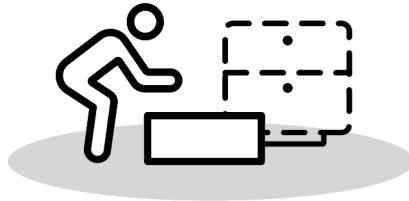
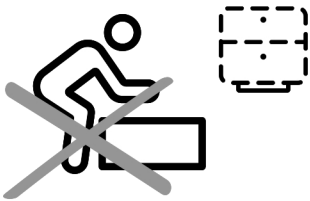

Suitable Location

Assembling near the area of the intended location is highly recommended.



Sufficient Space

Make sure you have enough space to move around during the assembly.

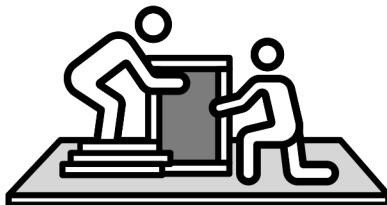

Avoid Scratches

Use cardboard, blankets or a carpeted area while assembling furniture to prevent scratches.

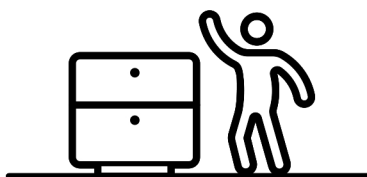
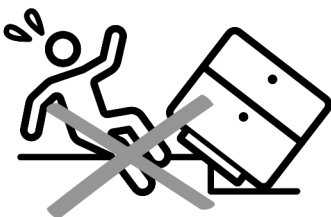

Flat Surface

Make sure the furniture rests on a flat and level surface with each leg evenly touching the floor.

ASSEMBLY AND CARE ADVICE



FAILURE TO FOLLOW THE GUIDELINES BELOW MAY RESULT IN INJURY AND/OR PROPERTY DAMAGE.

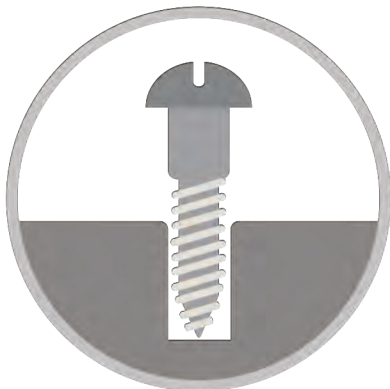

Position each part correctly and insert screws or bolts into their respective holes.

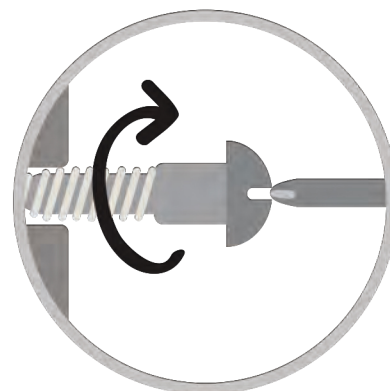

Turn clockwise to tighten and only tighten when step is completed or when instructed to do so.



Use the appropriate hand tools or power tools for assembly. Select steps, such as tightening screws and/or bolts, may require hand tools to avoid causing damage during assembly.



Save the instructions and store any supplied tools for later maintenance.

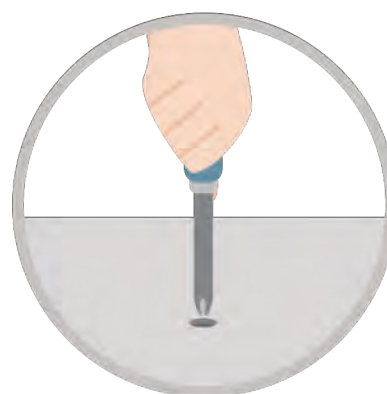

After two weeks, check and tighten any loose hardware and repeat again every six months thereafter.

IT IS THE USER'S RESPONSIBILITY TO MAINTAIN THE FURNITURE. THE HARDWARE MAY LOOSEN OVER TIME AND MAY CAUSE THE FURNITURE TO BE WOBBLY AND UNABLE TO SUPPORT ITS INTENDED WEIGHT CAPACITY. THIS MAY LEAD TO COLLAPSE AND MAY CAUSE SERIOUS INJURY.

FULL BED



- Please keep instructions for future reference.
- Check the quantity and irregularity of parts and hardware before you start.

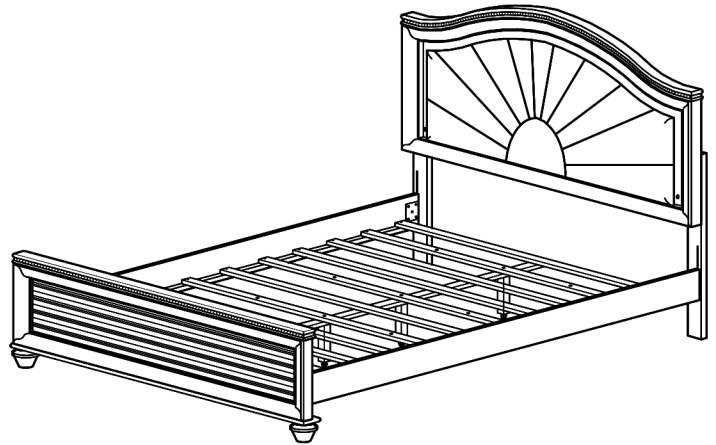

PARTS

PART LIST OF HEADBOARD

#1 1pc

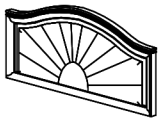

Headboard

#2 1pc

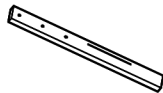

Headboard Leg - (R)

#3 1pc

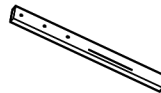

Headboard Leg - (L)

PART LIST OF FOOTBOARD

#4 1pc



Footboard

#5 2pcs



Acrylic Leg

#6 11pcs

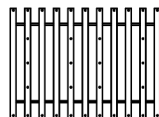

Roll Slat

#7 2pcs



Center Vertical Slat

#8 4pcs

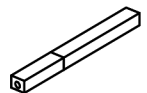

Slat Support Leg
285x30x30mm

PART LIST OF SIDE RAIL

#9 2pcs



Side Rail

HARDWARE

HARDWARE PACK IN HEADBOARD

#A 1pc



Allen Key

#B 6pcs



JCBC - M6 x35mm

#C 6pcs



M6 Spring Washer

#D 6pcs



M6 Flat Washer

#E 1pc



AC Adaptor

HARDWARE PACK IN FOOTBOARD

#F 1pc



Allen Key

#G 4pcs



JCBC - M6 x 60mm

#H 4pcs



M6 Spring Washer

#I 22pcs

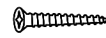









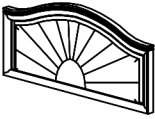

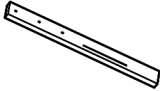

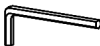

Screw 32mm

#J 4pcs

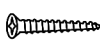
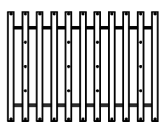
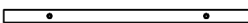
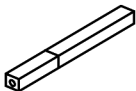

Adjustable Leveller

Carton	Designation		Part	Hardware
	Headboard (1pc)	#1		 #A x 1pc  #B x 6pcs
	Headboard Leg - (R) (1pc)	#2		 #C x 6pcs  #D x 6pcs
	Headboard Leg - (L) (1pc)	#3		 #E x 1pc
	Footboard (1pc)	#4		 #F x 1pc  #G x 4pcs
	Bun foot (2pcs)	#5		 #H x 4pcs  #I x 22pcs
	Slat (11pcs)	#6		
	Center Vertical Slat (2pcs)	#7		
	Slat Support Leg (4pcs)	#8		
	Side Rail (2pcs)	#9		

ASSEMBLY INSTRUCTIONS

1 Part #1 x 1pc

Part #2 x 1pc

Part #3 x 1pc

Hardware #A x 1pc

Hardware #B x 6pcs

Hardware #C x 6pcs

Hardware #D x 6pcs

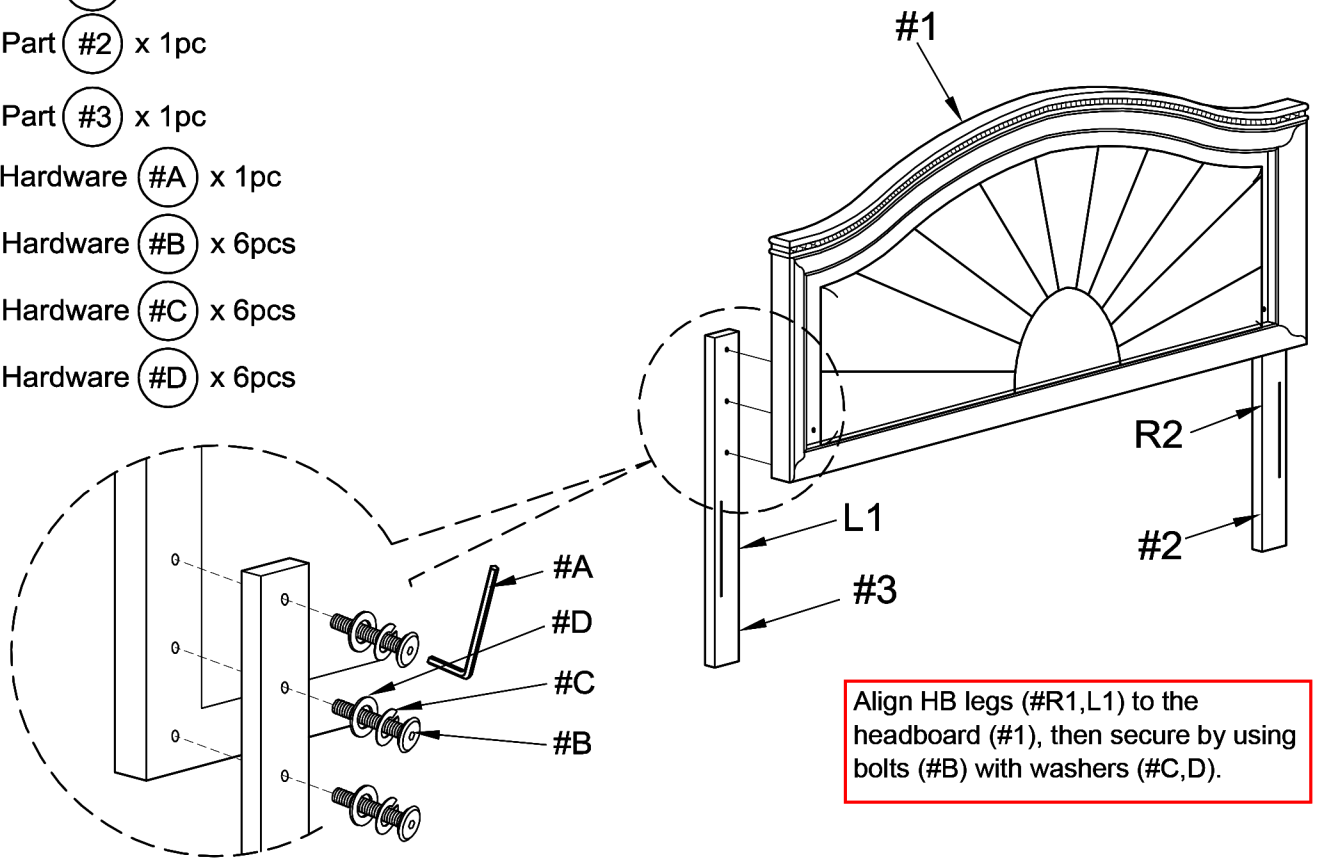

2

Hardware #E x 1pc

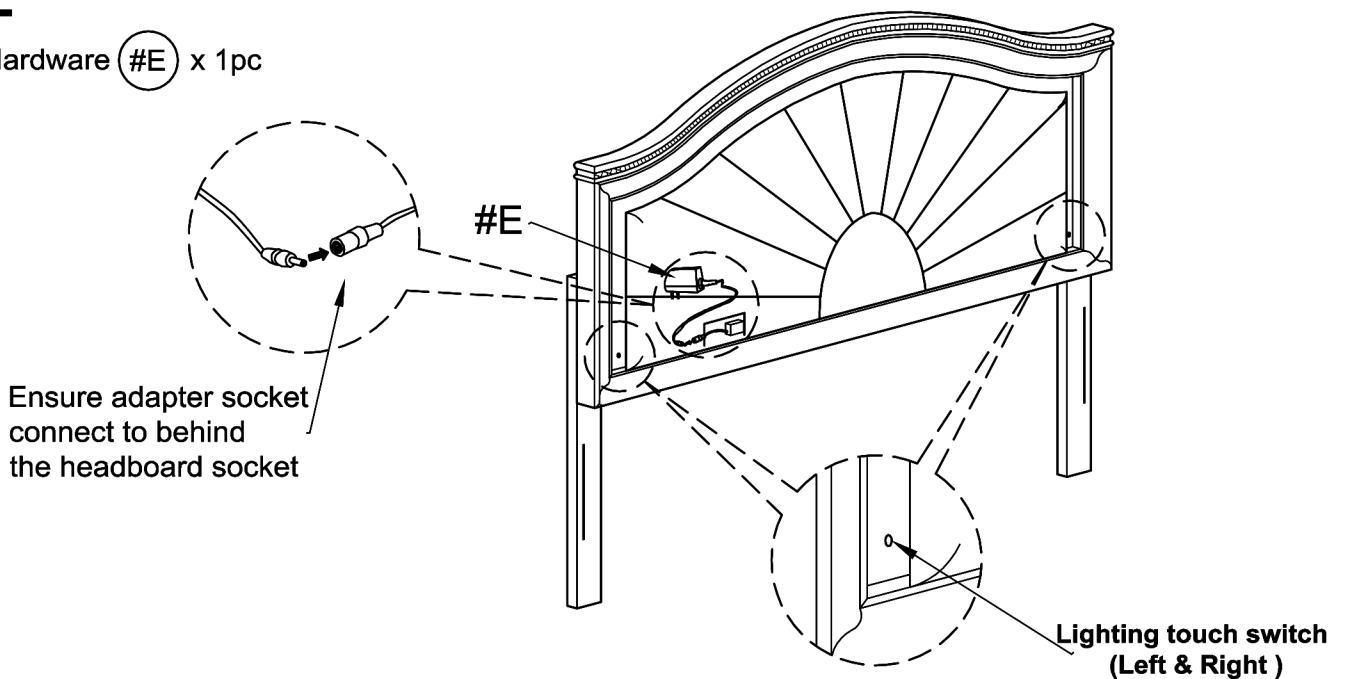

ASSEMBLY INSTRUCTIONS

3

Part #4 x 1pc

Part #5 x 2pcs

Attach legs (#5) to the footboard (#4).

Bun Foot cover



Remove Acrylic Leg cover before assemble.

#5

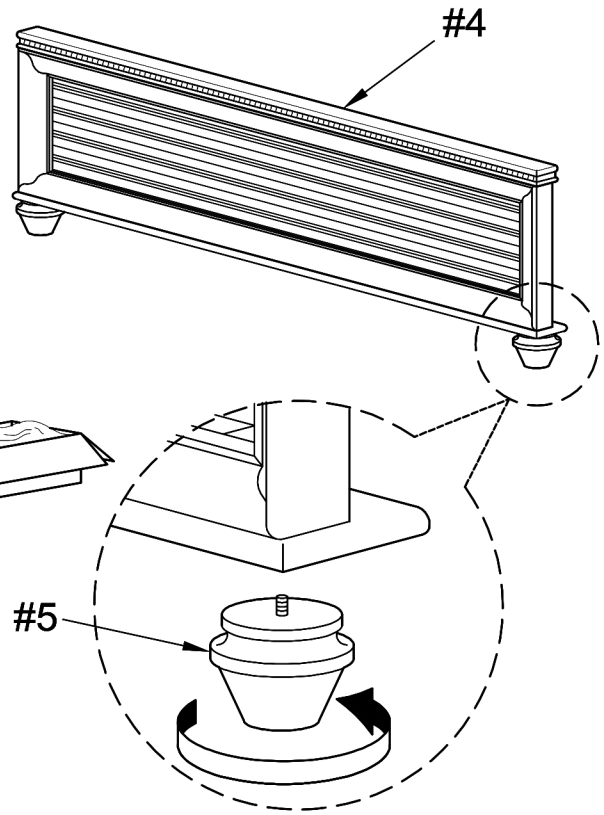

4

Part #1 x 1pc

Part #9 x 2pcs

Align and hook the side rails (#9) to the latches of the headboard (#1) and footboard (#4).

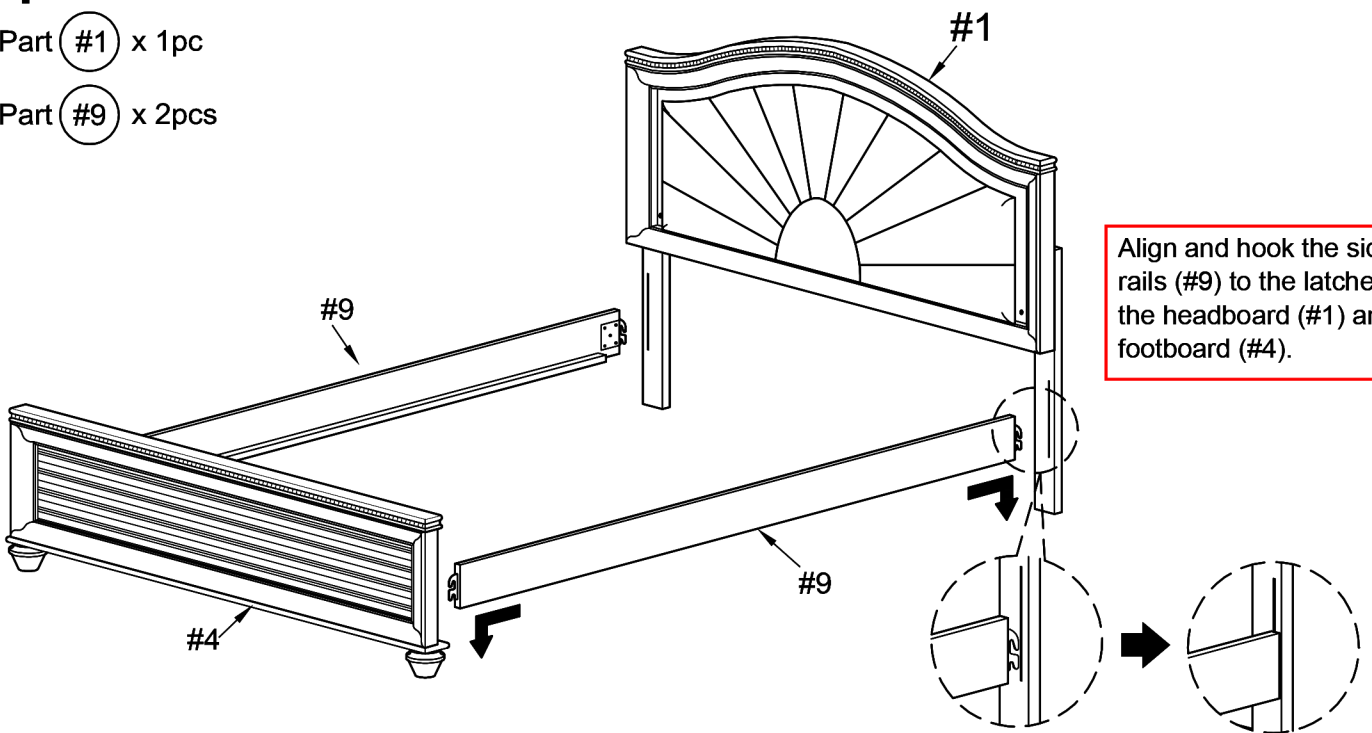

ASSEMBLY INSTRUCTIONS

- 5** Part **#6** x 11pcs Hardware **#F** x 1pc
 Part **#7** x 2pcs Hardware **#G** x 4pcs
 Part **#8** x 4pcs Hardware **#H** x 4pcs
 Hardware **#I** x 22pcs
 Hardware **#J** x 4pcs

Align slats (#6) to the side rails (#9), then secure by using screws (#I).

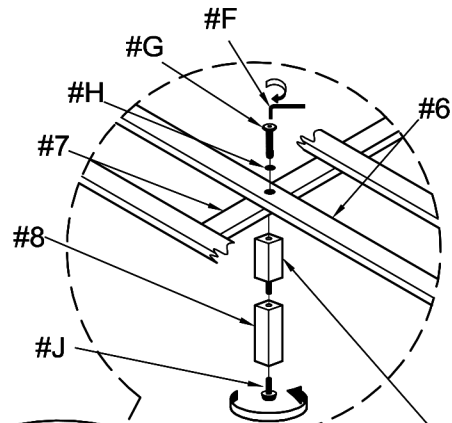

#remove extension support leg.

Align center slat (#7) to the slats (#6), then secure by using bolts (#G) with washers (#H) onto support legs (#8). Attach and adjust adjustable leveler (#J) to the support legs (#8).

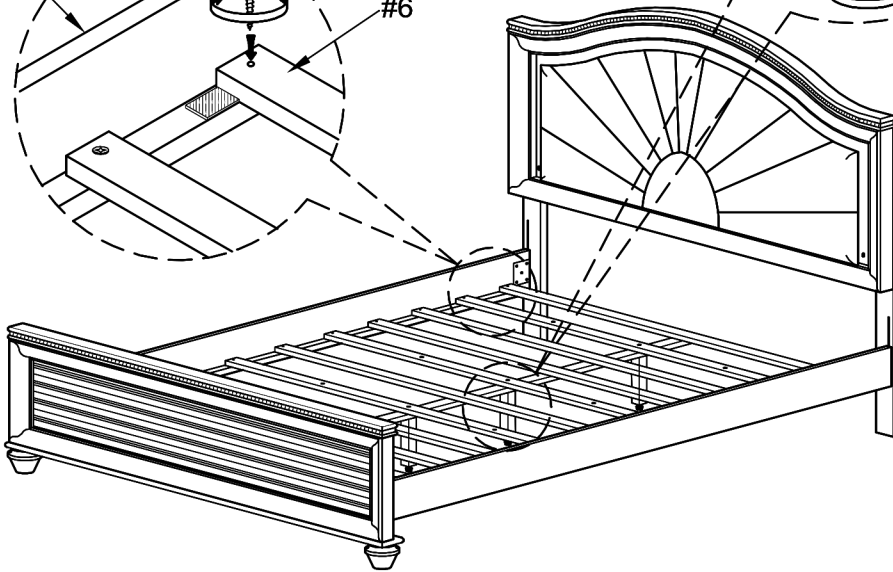
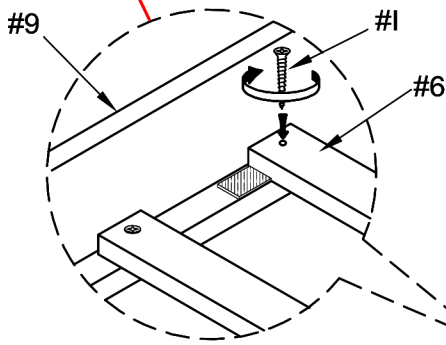

6

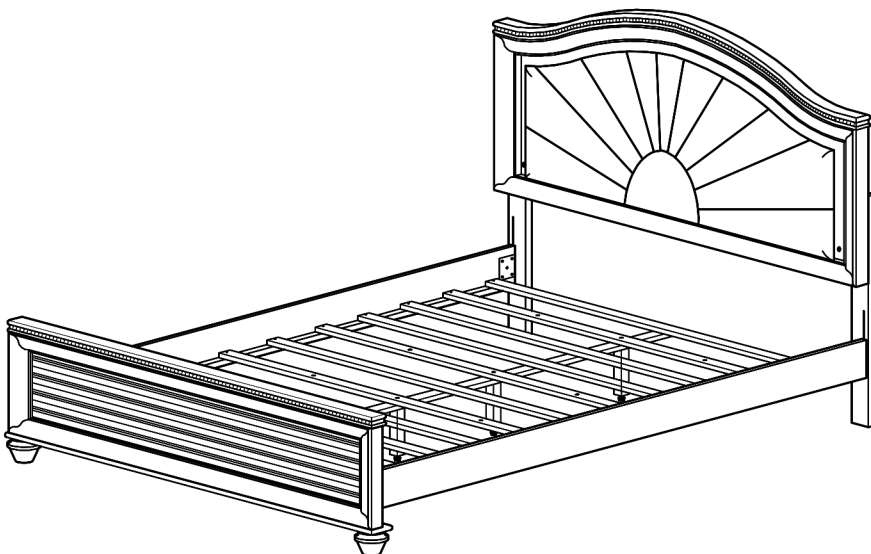

ASSEMBLY COMPLETED



Please ensure the furniture rests on an even and flat surface. If the product wobbles or feels loose, double-check all bolts and/or screws are properly tightened and secured.



Keep this handy!

Please retain this instruction manual and any order-related information for future reference.



Lift, don't drag!

To avoid damage to product please always LIFT the product when transporting or adjusting the placement.