



Before you begin, please read Page 2 of "Assembly and Care Advice".

And remember, do not tighten until each step is completed or instructed.

MD

Parts List

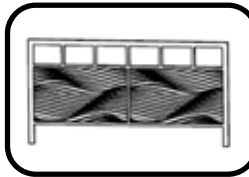

#1 x 1 pc
Headboard

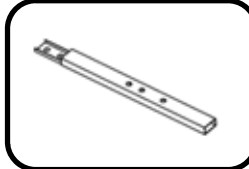

#2 x 2 pcs
Headboard Leg

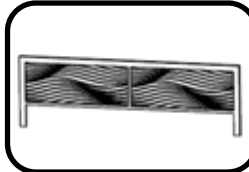

#3 x 1 pc
Footboard

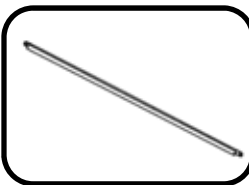

#4 x 1 pc
H/B Leg Rail

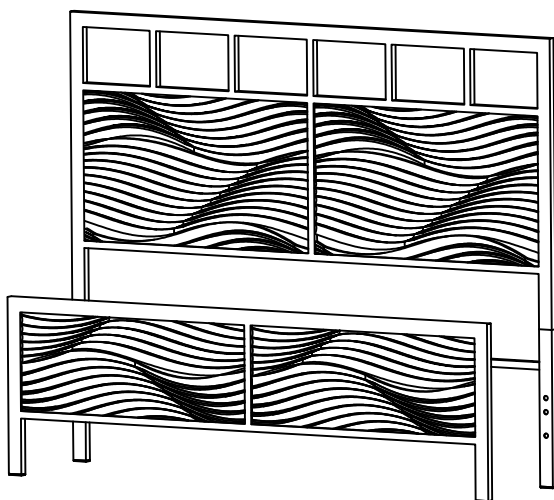

Hardware List

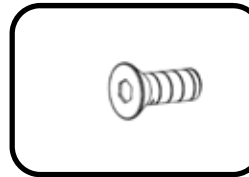

#A x 10 pcs
F/H Bolt 1/4"x5/8"

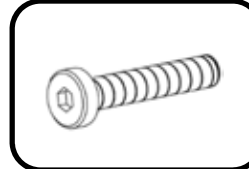

#B x 8 pcs
Bolt 1/4"x7/8"

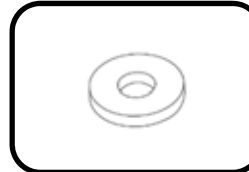

#C x 8 pcs
Plastic Washer



#D x 8 pcs
Flat Washer



#E x 8 pcs
Lock Washer

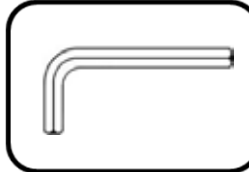

#F x 1 pc
Allen Wrench



#G x 2 pcs
Bracket

Due to the size and/or weight of this product, it is highly recommended that the assembly should be done near the area of its intended location. Make sure you have enough space to move around during the assembly. ALWAYS have at least two people to help with transporting and assembling the product to avoid any potential injury and/or damage.



- I. Align the 2 headboard legs (#2) with the pre-drilled holes on the headboard (#1). Then align the 2 brackets (#G) with the headboard (#1) and the headboard legs (#2).
- II. Insert 8 flat-head bolts (#A) through the brackets (#G) using the Allen wrench (#F) to lock them with the headboard (#1) and the legs (#2).

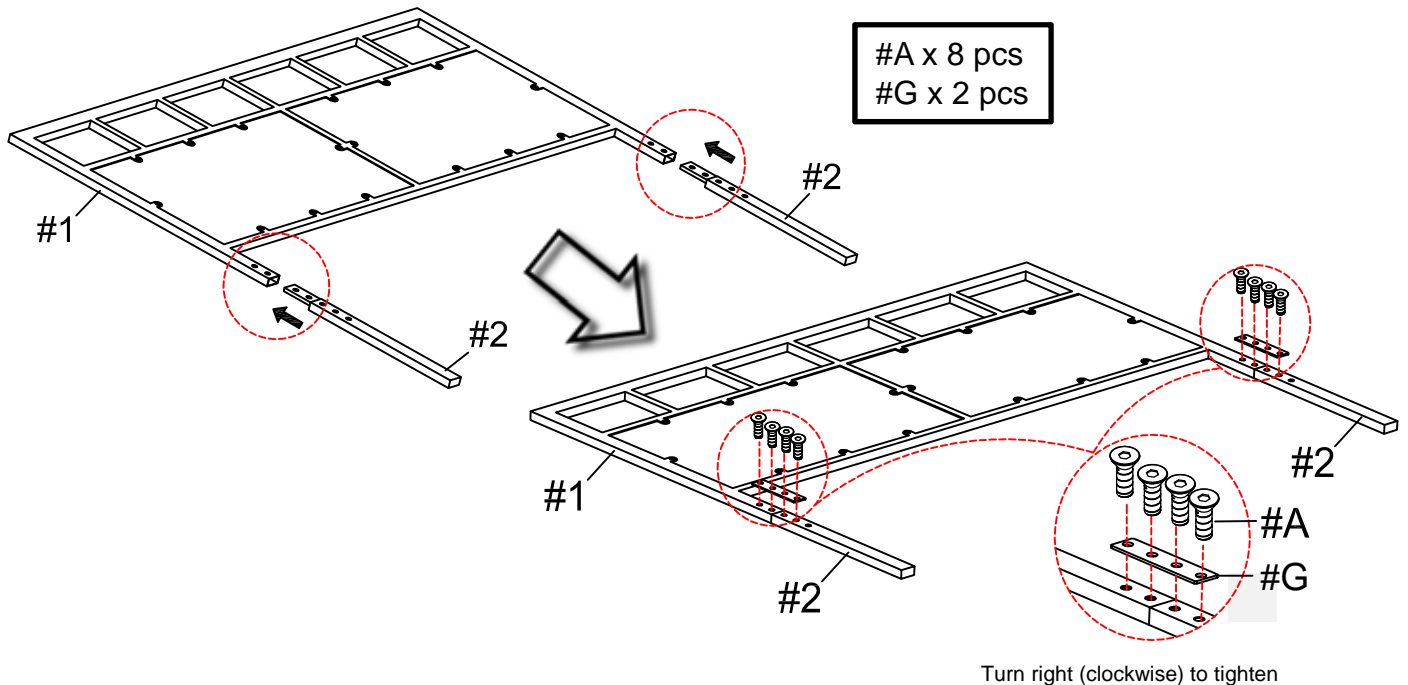

- I. Align the headboard leg rail (#4) with the pre-drilled holes on the 2 headboard legs (#2).
- II. Insert 2 flat-head bolts (#A) through the headboard leg rail (#4) using the Allen wrench (#F) to lock them with the headboard legs (#2).

Turn right (clockwise) to tighten

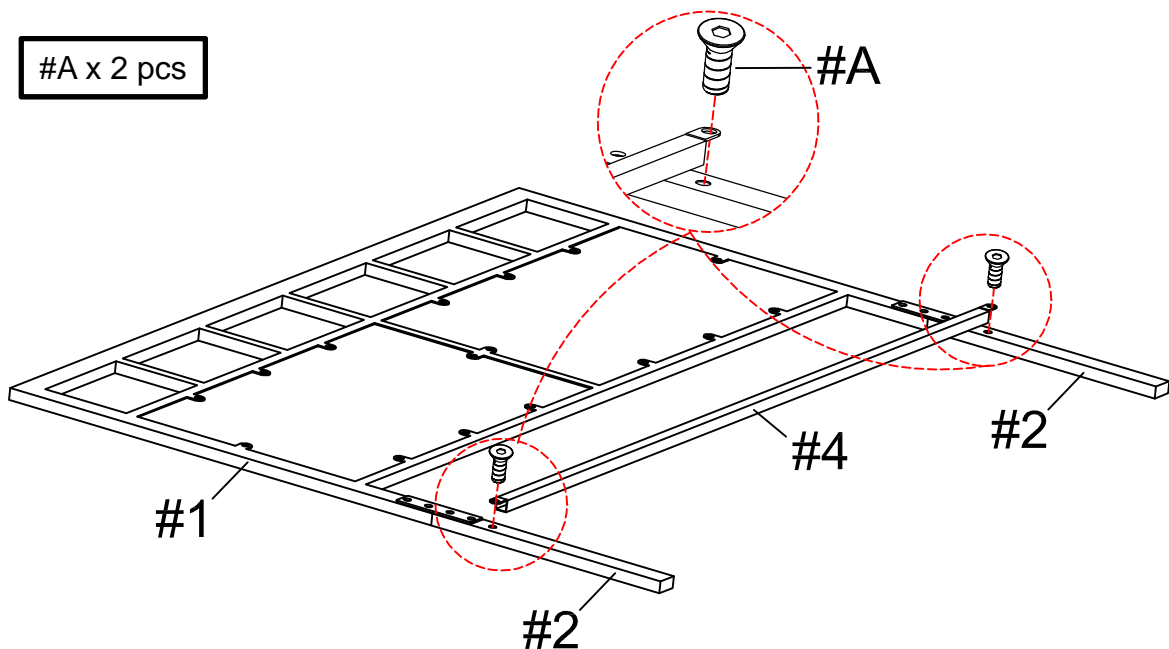

ASSEMBLING THE BED FRAME TO THE HEADBOARD/FOOTBOARD

This is an optional step to assemble the headboard/footboard onto the bed frame (sold separately).

- I. Align the holes of the bed frame with the holes on the headboard legs (#2) of the assembled headboard.
- II. Prepare 4 bolt assemblies by inserting FIRST the lock washer (#E) onto the bolt (#B) and then the flat washer (#D) onto the SAME bolt (#B), in that order.
- III. Insert the bolt assemblies through the bed frame, then insert 4 plastic washers (#C) onto the same bolts (#B) and secure those bolts using the Allen wrench (#F) to lock them in with the headboard legs (#2).
- IV. Repeat the process above to assemble the other ends of the bed frame onto the footboard (#3).

