

Assembly Instructions

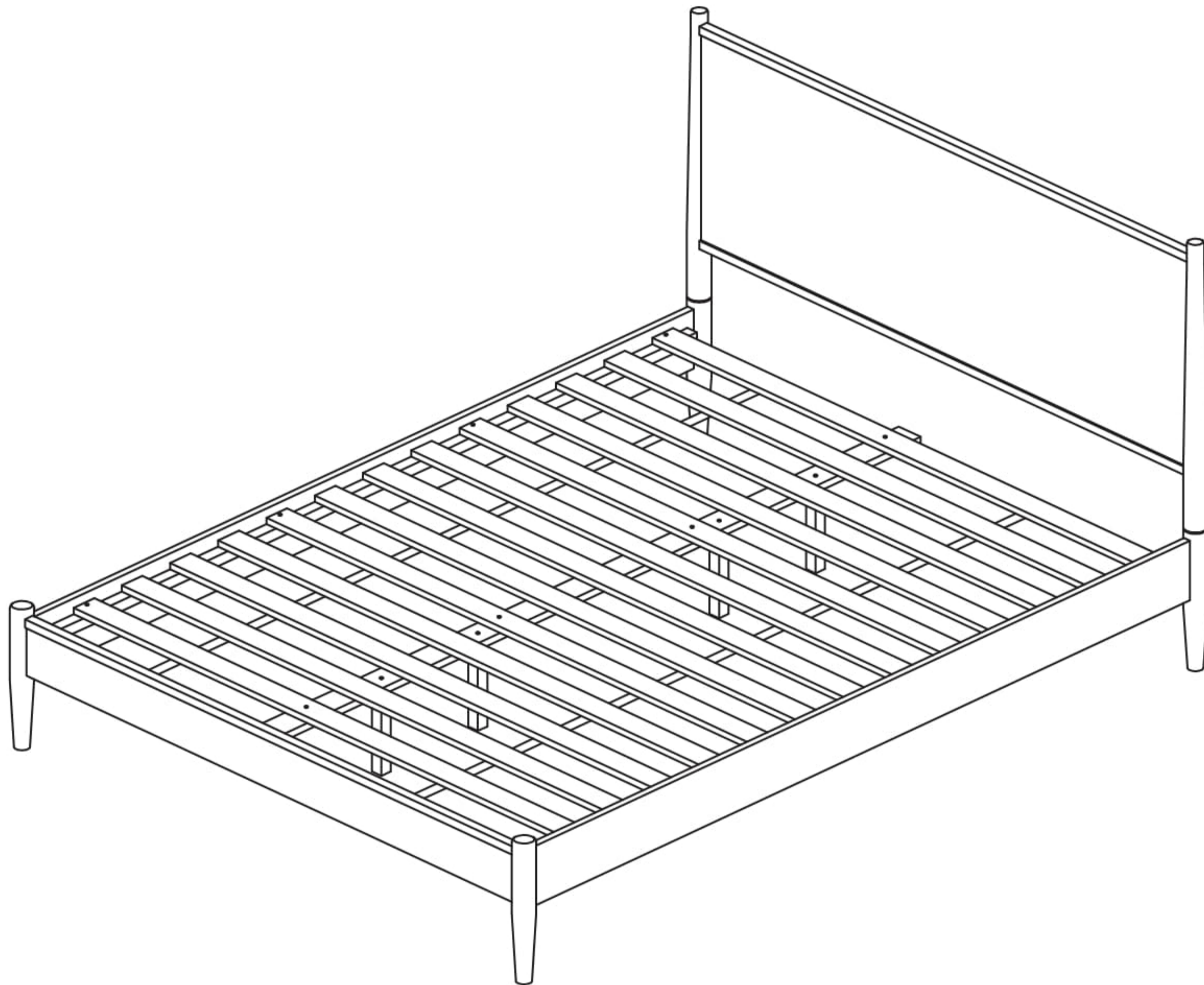

ASSEMBLY RATING

The Assembly Rating is a 5-point system that shows the degree of effort needed in assembling a specific product (with 1 being easy and 5 being difficult). For some products, two persons are recommended.

Tools Required For Assembly:

Allen Wrench

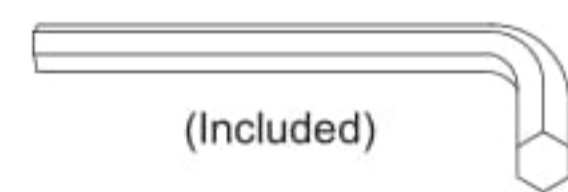

Phillips Screwdriver

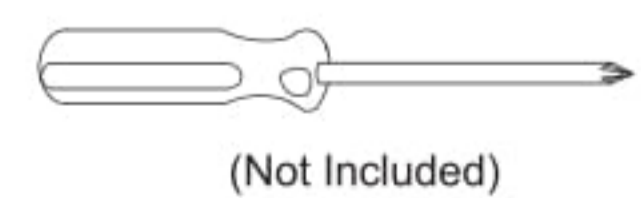

EASY



DIFFICULT



2 PERSONS RECOMMENDED

ASSEMBLY & CARE ADVICE

FOR YOUR FURNITURE TO LAST, CORRECT ASSEMBLY AND PROPER MAINTENANCE ARE NECESSARY. PLEASE FOLLOW THE INFORMATION PROVIDED BELOW TO FULLY ENJOY YOUR FURNITURE.

BASIC ASSEMBLY TECHNIQUES

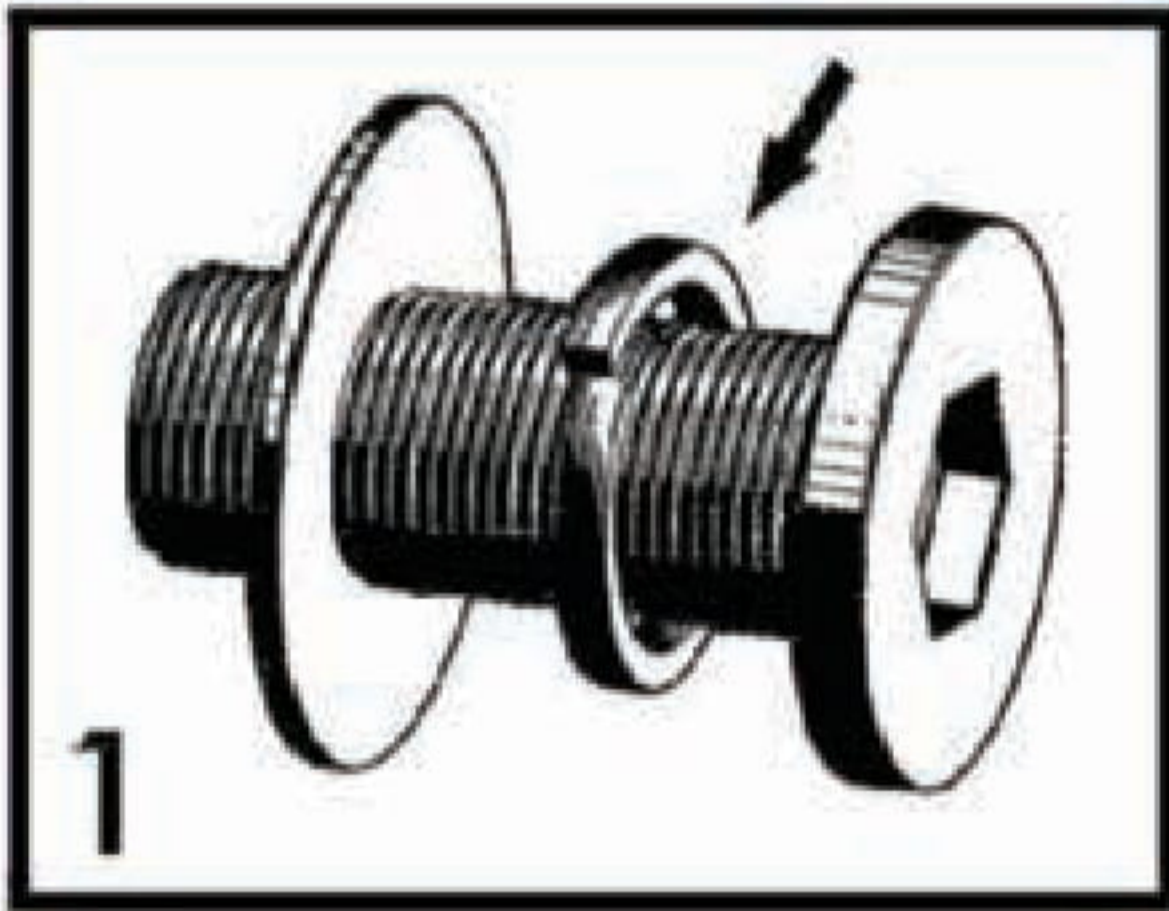

When lock or spring washer is used in an assembly, please make sure the lock or spring washer is placed between the larger flat washer and the head of the screw or bolt.

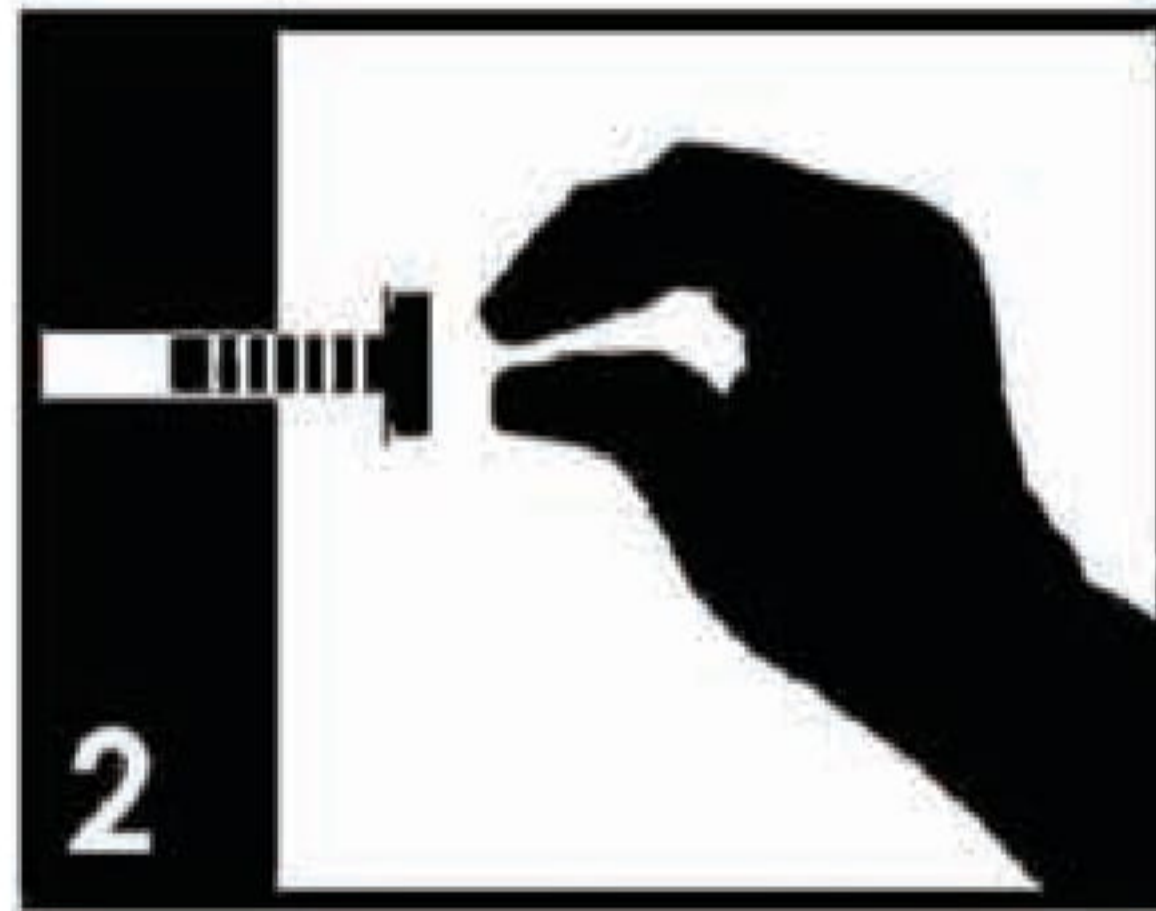

Position each part correctly and insert screws or bolts into their respective holes by hand tighten or using the proper hand tool. Only tighten when step is completed or when instructed to do so.



Use cardboard or carpet area when assembling furniture to prevent scratches. Make sure the furniture rests on a flat and level surface with each leg evenly touching the floor.

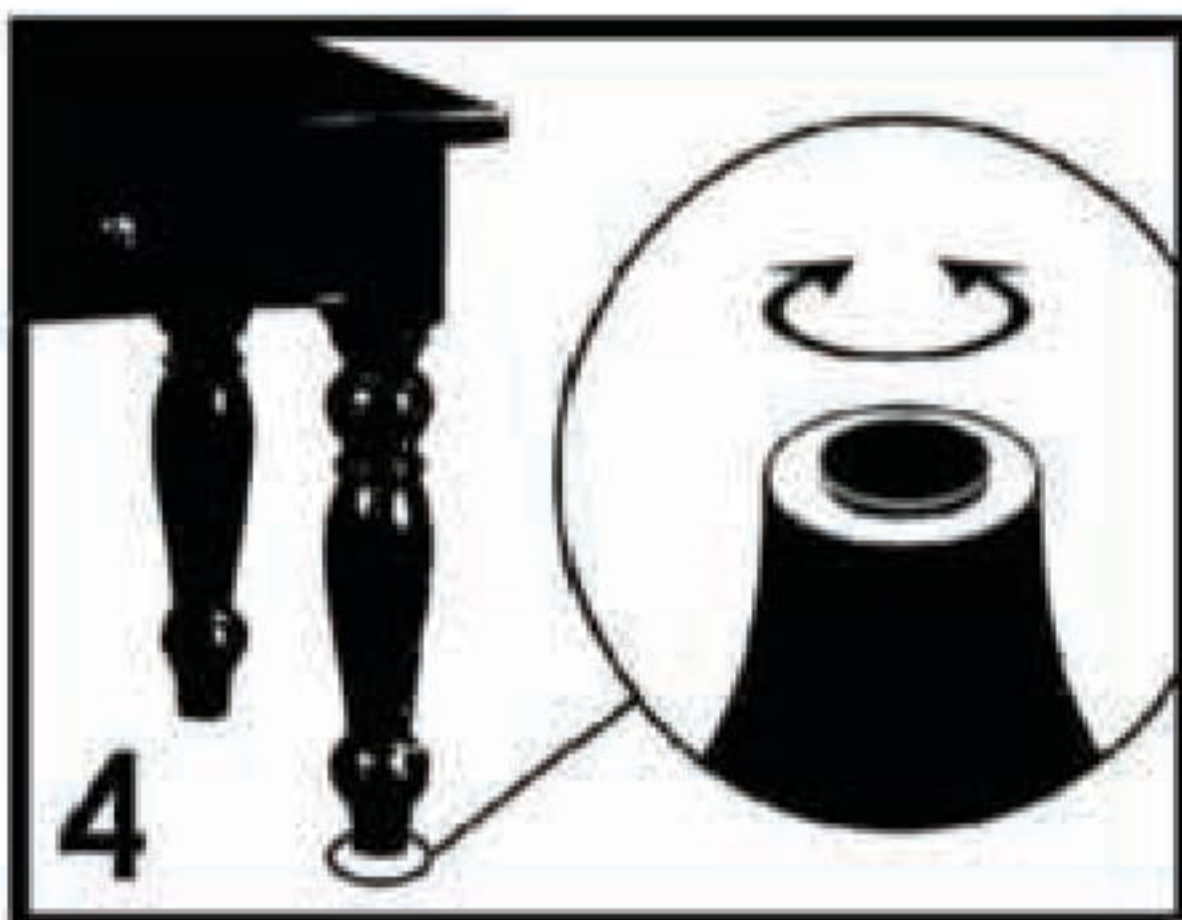

Some furniture comes with height adjustment knobs underneath each leg. To lower or to raise each leg, you need to turn clockwise or counterclockwise, respectively.

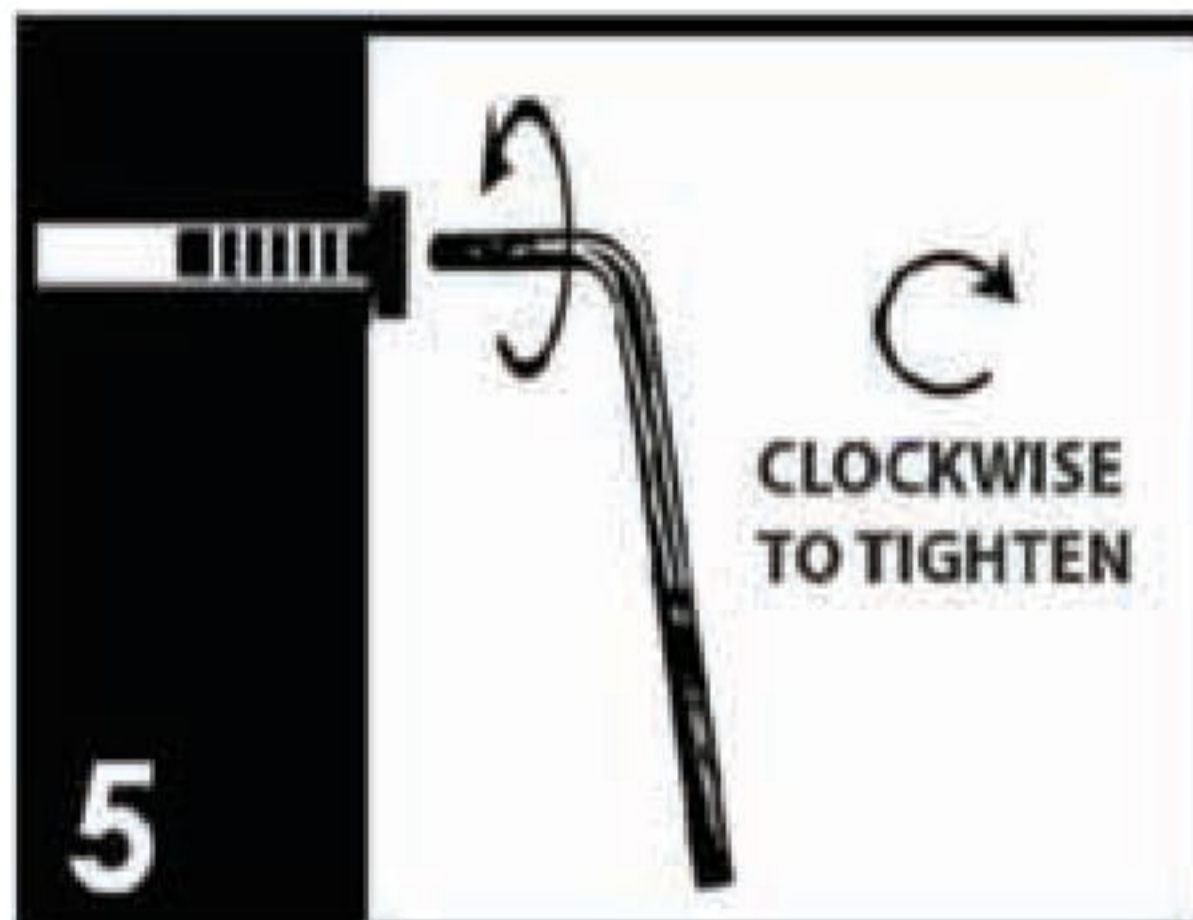

Make sure all parts are properly aligned, then use the appropriate hand tool to completely tighten the bolts or screws. Do not use power tools and do not overtighten.

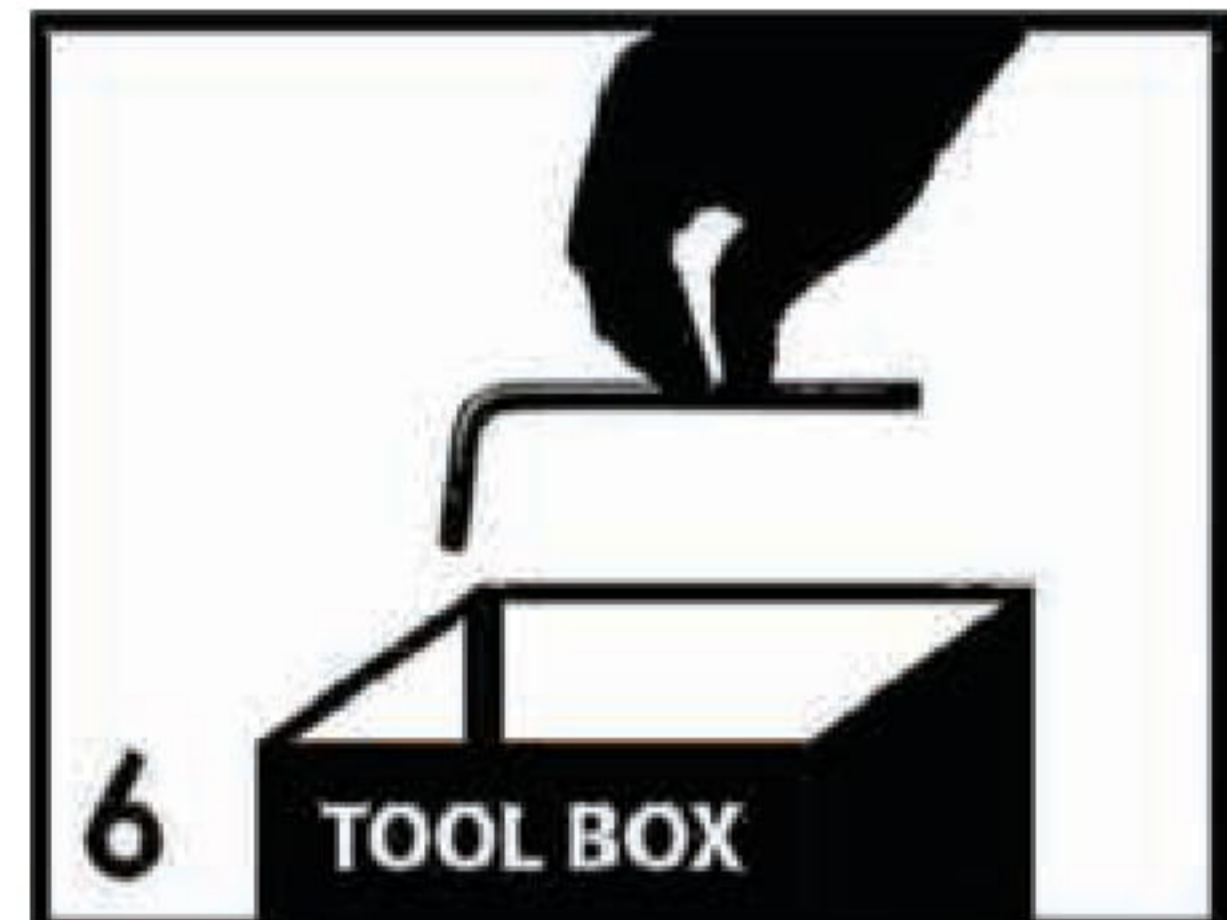

Save the instructions and store the Allen wrench or any supplied tool for later maintenance. After two weeks, check and tighten any loose hardware and repeat again every six months thereafter.

IT IS THE USER'S RESPONSIBILITY TO MAINTAIN THE FURNITURE. THE HARDWARE MAY LOOSEN OVER TIME AND MAY CAUSE THE FURNITURE TO BE WOBBLY AND UNABLE TO SUPPORT ITS INTENDED WEIGHT CAPACITY. THIS MAY LEAD TO COLLAPSE AND MAY CAUSE SERIOUS INJURY.



FAILURE TO FOLLOW THE GUIDELINES ABOVE MAY RESULT IN INJURY AND/OR PROPERTY DAMAGE.



Before you begin, please read Page 2 of "Assembly and Care Advice".

And remember, do not tighten until each step is completed or instructed.

Parts List

Hardware List

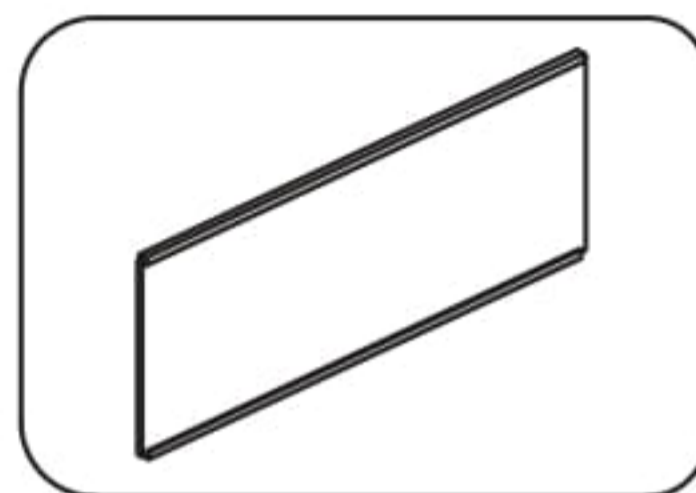

#1 x 1pc
Headboard

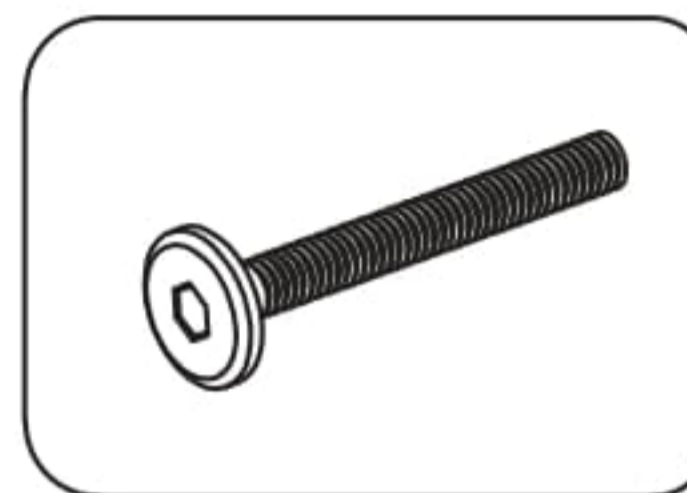

#A x 6pcs
Bolt $\text{Ø}1/4"$ x 1-3/8"

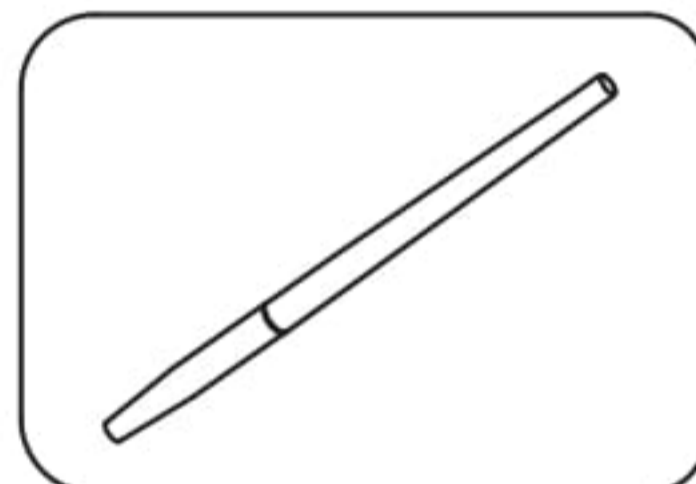

#2 x 2pcs
Headboard Leg (L&R)

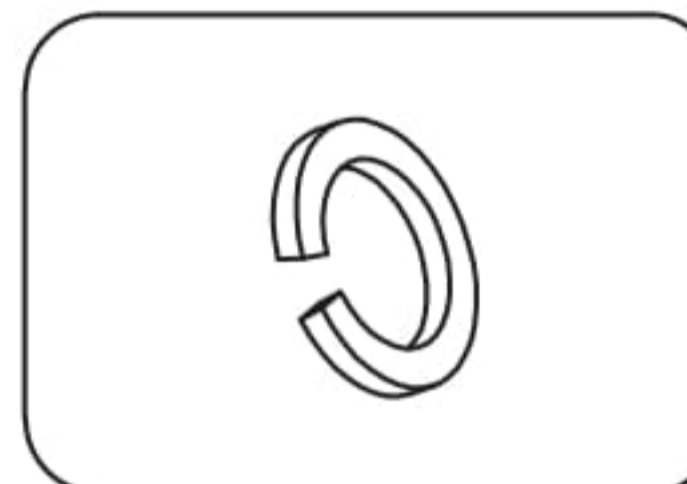

#B x 6pcs
Lock washer $\text{Ø}1/4"$

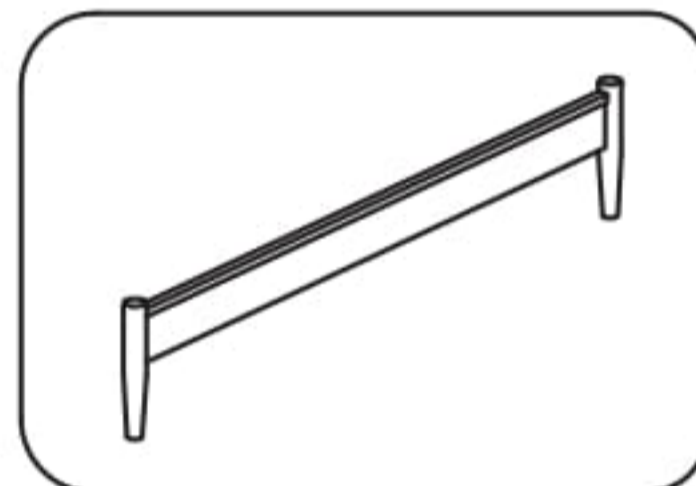

#3 x 1pc
Footboard

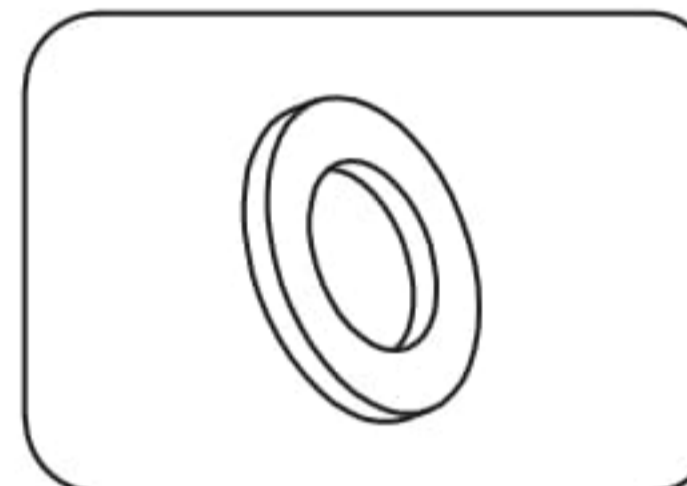

#C x 6pcs
Flat washer $\text{Ø}1/4"$ -3/4"

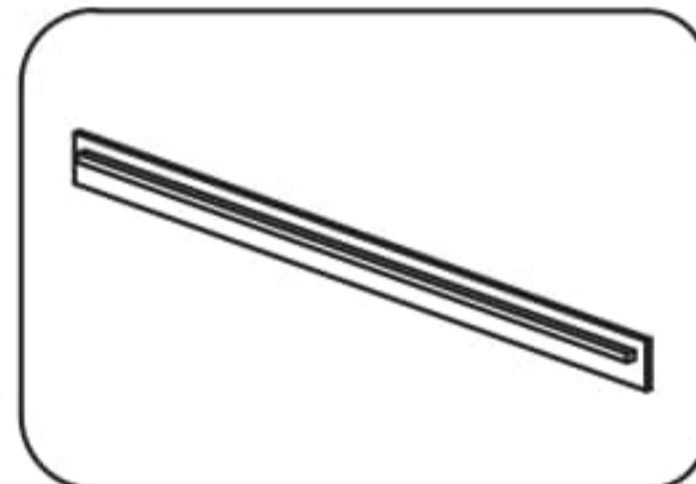

#4 x 2pcs
Rail

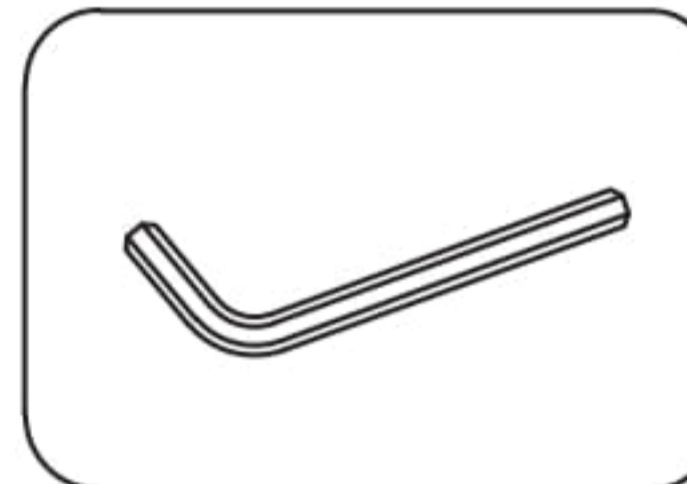

#D x 1pc
Allen wrench M4

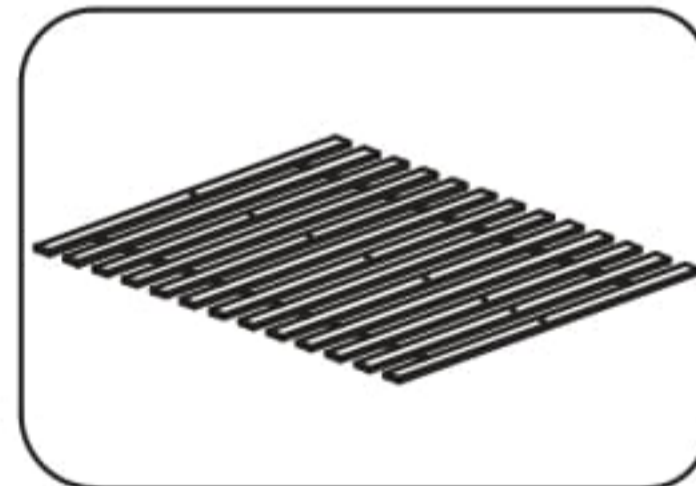

#5 x 1Set (13pcs)
Bed Slat

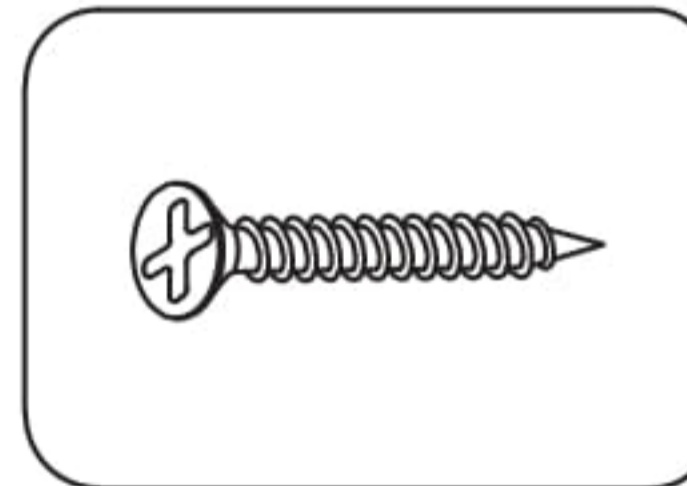

#E x 12pcs
Screw #5/32"x1-3/16"

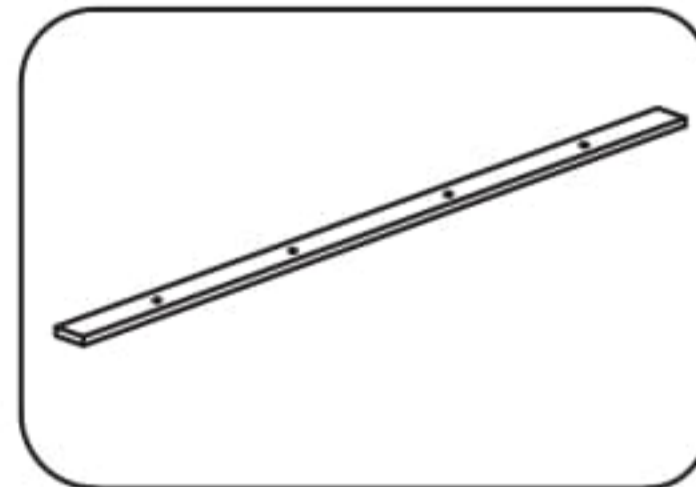

#6 x 1pc
Center Rail

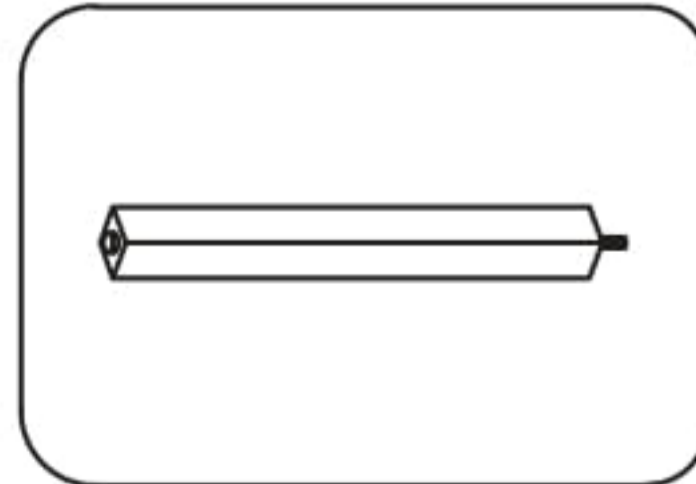

#7 x 4pcs $\text{Ø}5/16$
Support Leg (310x30x30mm)



Prepare 6 bolts assembly by inserting lock washer (#B), then flat washer (#C) onto bolts (#A).
Align headboard legs (#2R/L) to the holes of the headboard (#1). Secure with bolts (#A).

#A x 6pcs
#B x 6pcs
#C x 6pcs

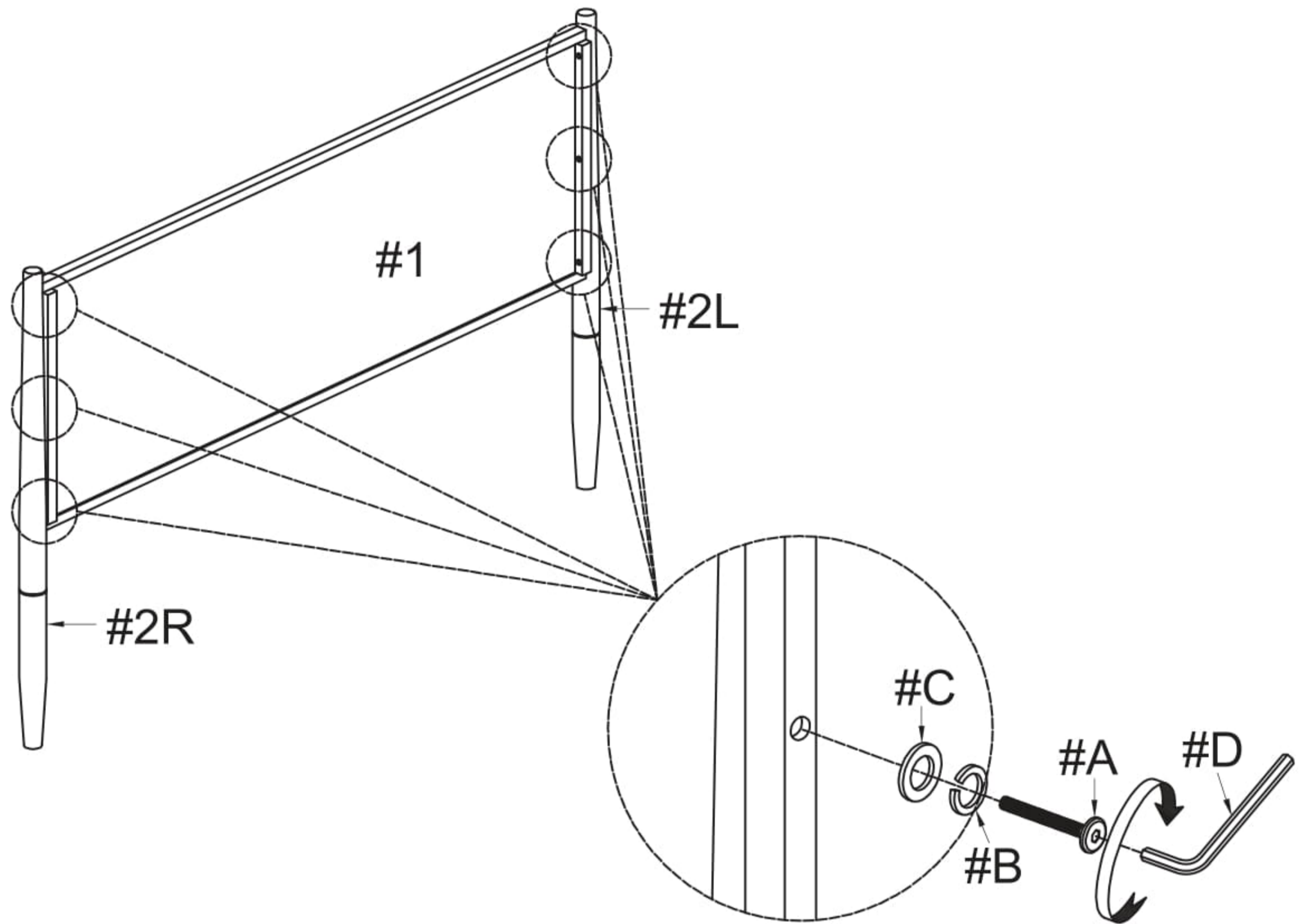

Hook the side rails (#4) to the latch of the headboard (#1) and footboard (#3).
Make sure the side rails (#4) are on firmly.

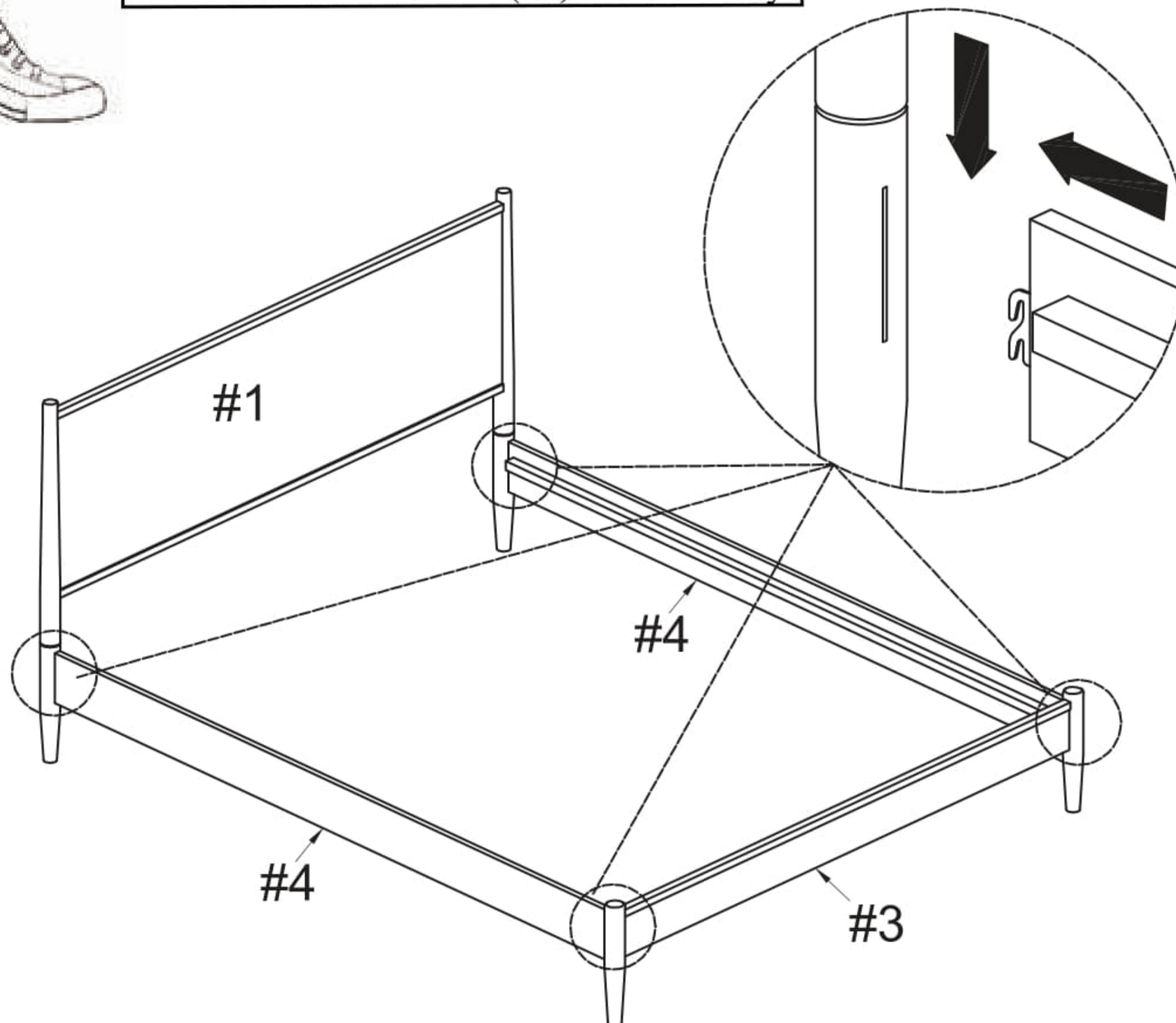



Attach 4 support legs (#7) to center rail (#6). Adjust floor protector according to ground level.

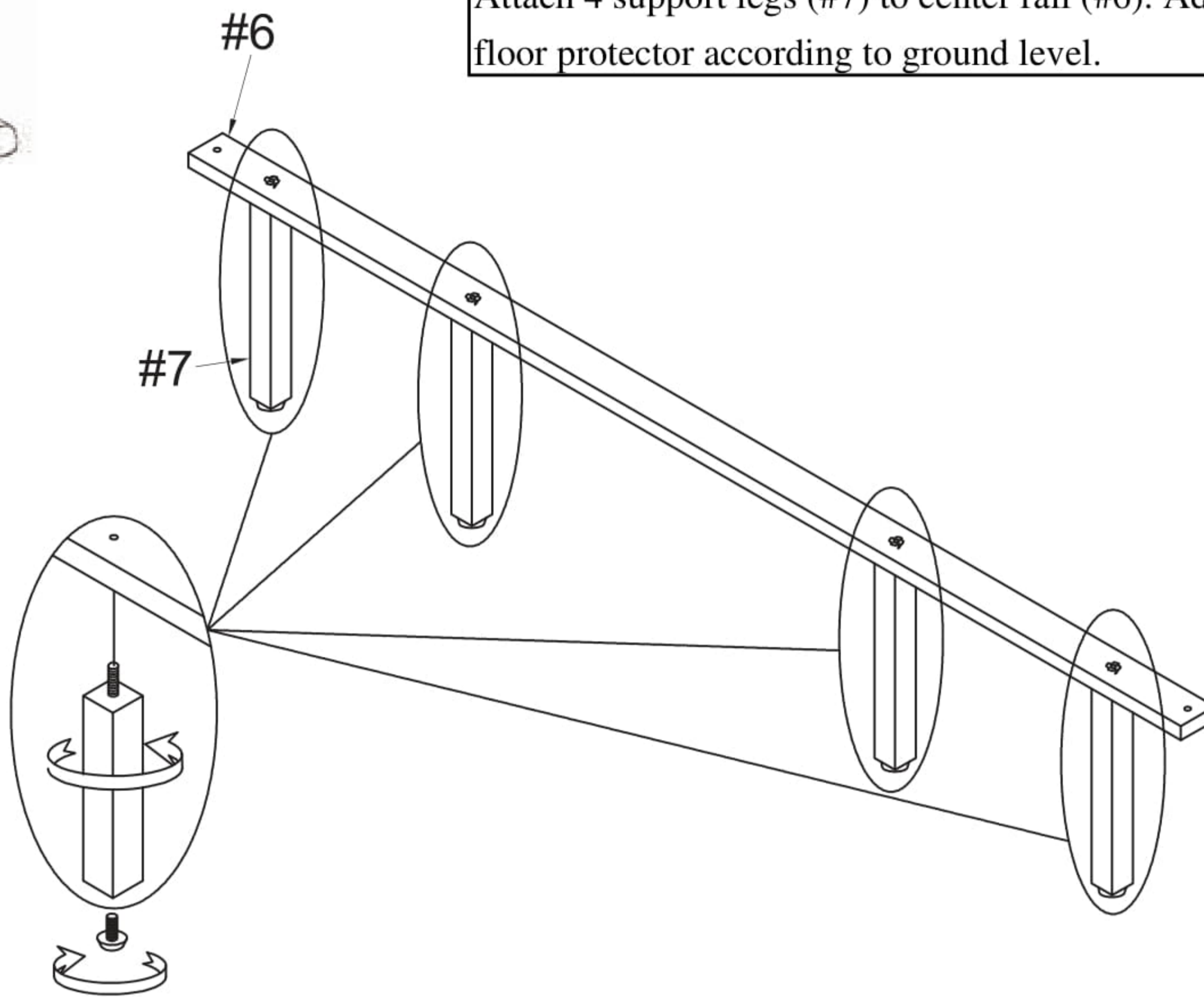

Align slats (#5) to the side rails (#4) and center rail (#6), then secure with screws (#E).

#E x 12pcs

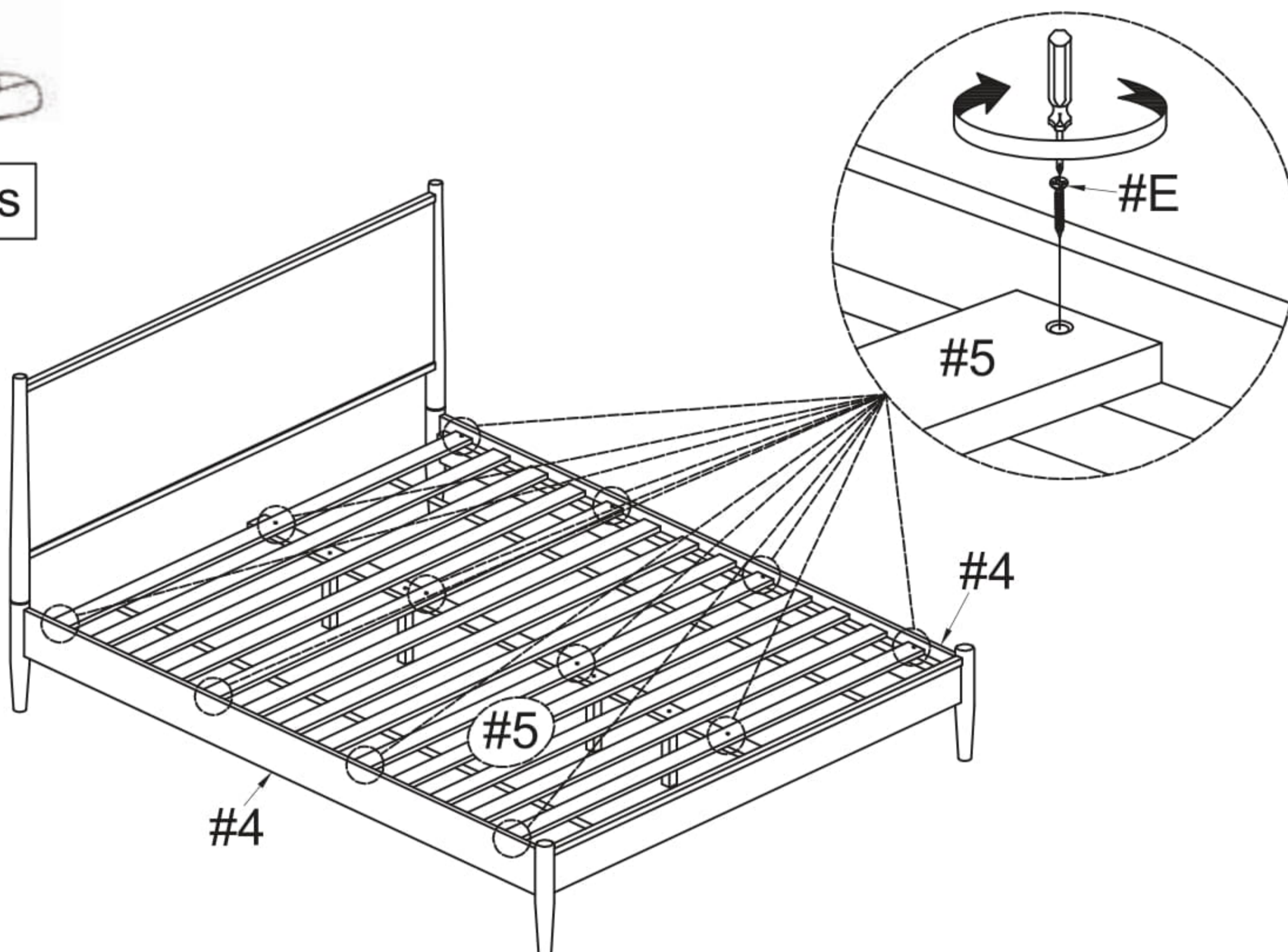

ASSEMBLY IS COMPLETED

Assembly Instructions

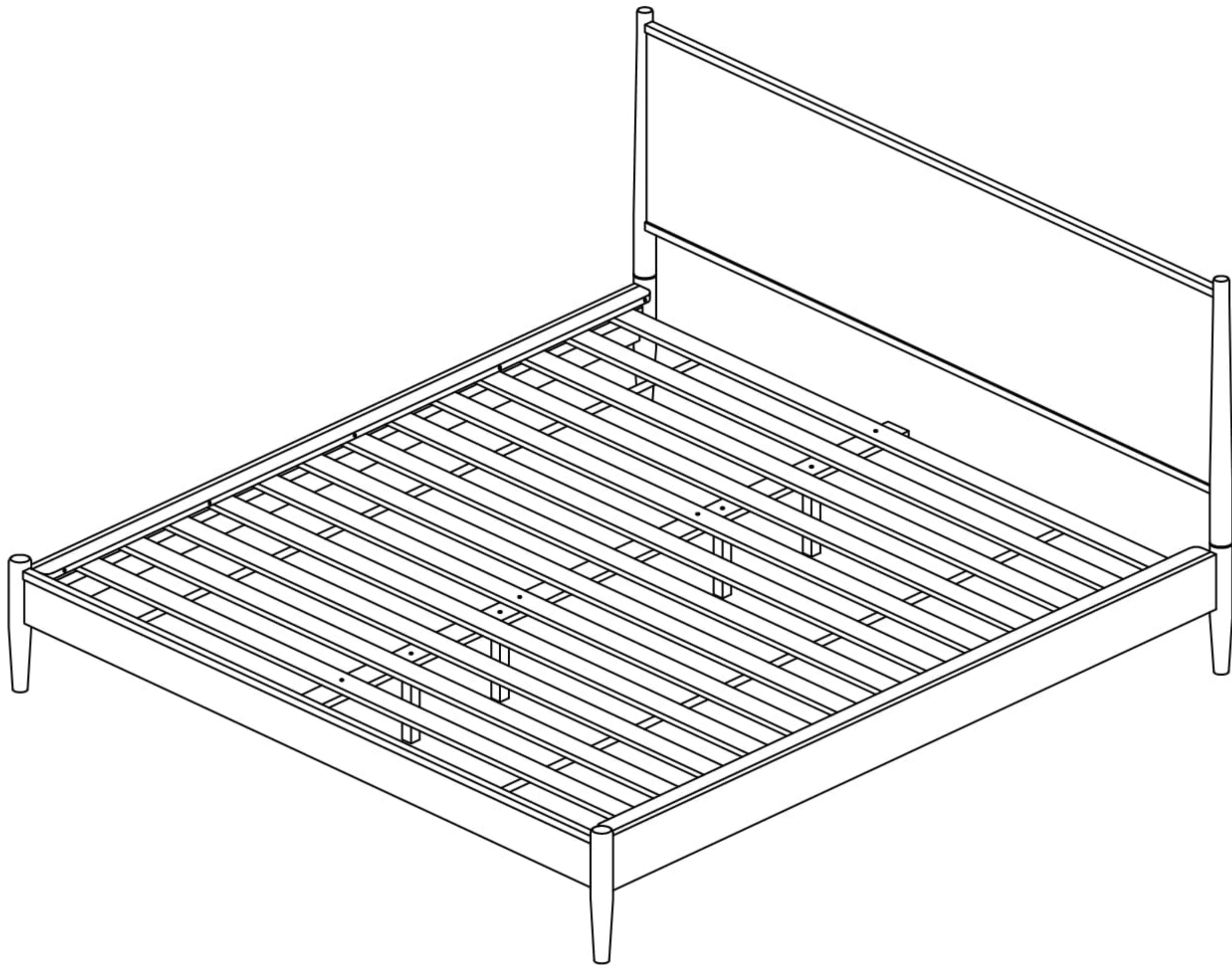

ASSEMBLY RATING

The Assembly Rating is a 5-point system that shows the degree of effort needed in assembling a specific product (with 1 being easy and 5 being difficult). For some products, two persons are recommended.

Tools Required For Assembly:

Allen Wrench

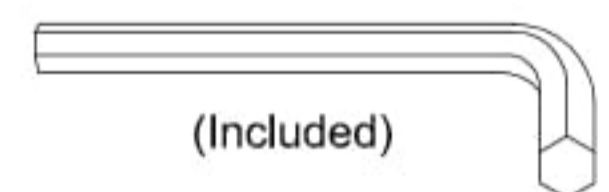

Phillips Screwdriver

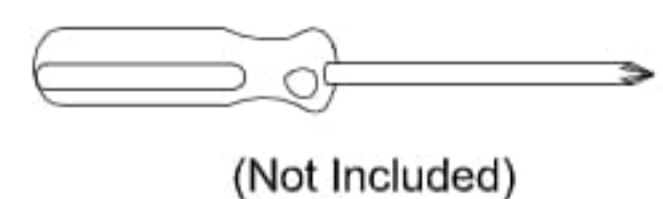

EASY  DIFFICULT



2 PERSONS RECOMMENDED

ASSEMBLY & CARE ADVICE

FOR YOUR FURNITURE TO LAST, CORRECT ASSEMBLY AND PROPER MAINTENANCE ARE NECESSARY. PLEASE FOLLOW THE INFORMATION PROVIDED BELOW TO FULLY ENJOY YOUR FURNITURE.

BASIC ASSEMBLY TECHNIQUES

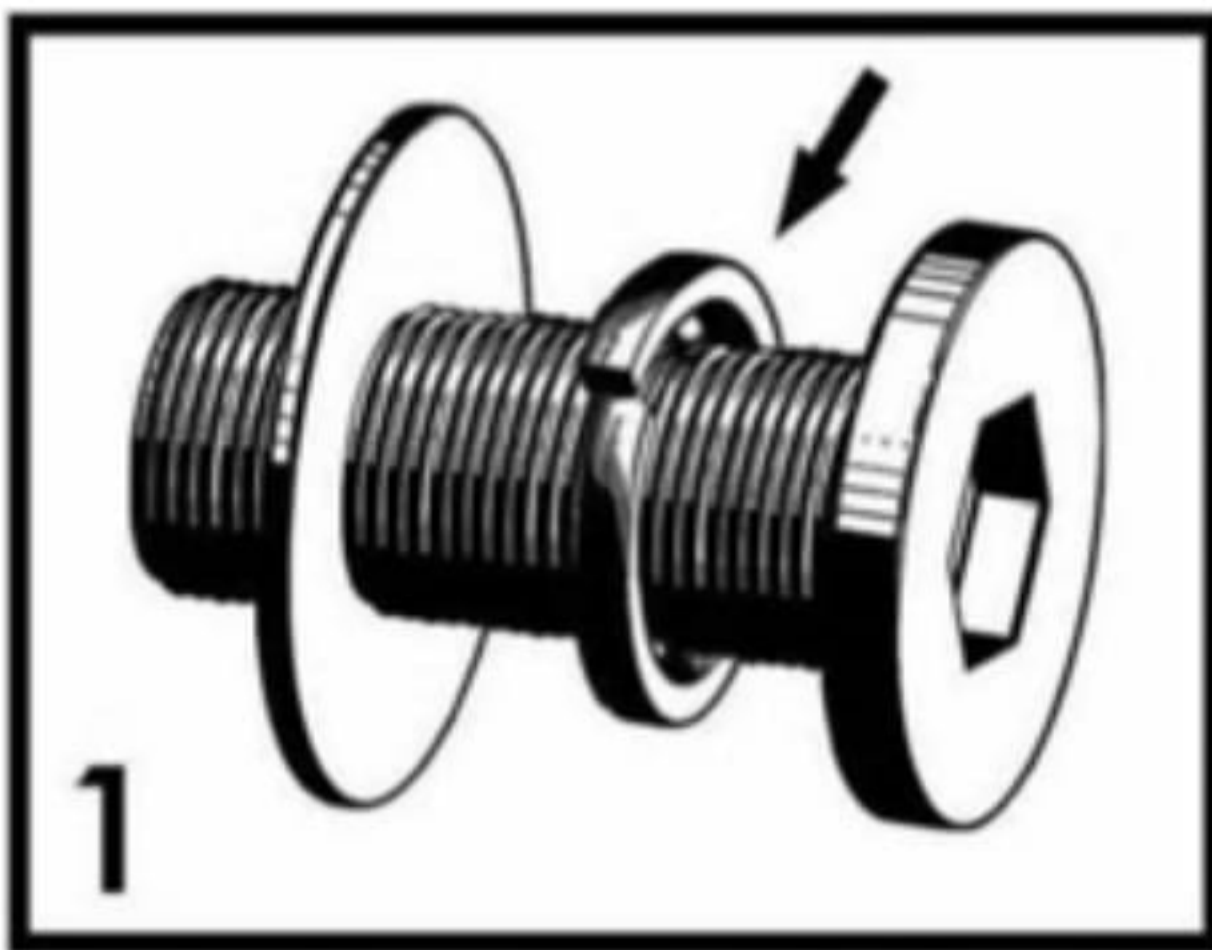

When lock or spring washer is used in an assembly, please make sure the lock or spring washer is placed between the larger flat washer and the head of the screw or bolt.



Position each part correctly and insert screws or bolts into their respective holes by hand tighten or using the proper hand tool. Only tighten when step is completed or when instructed to do so.

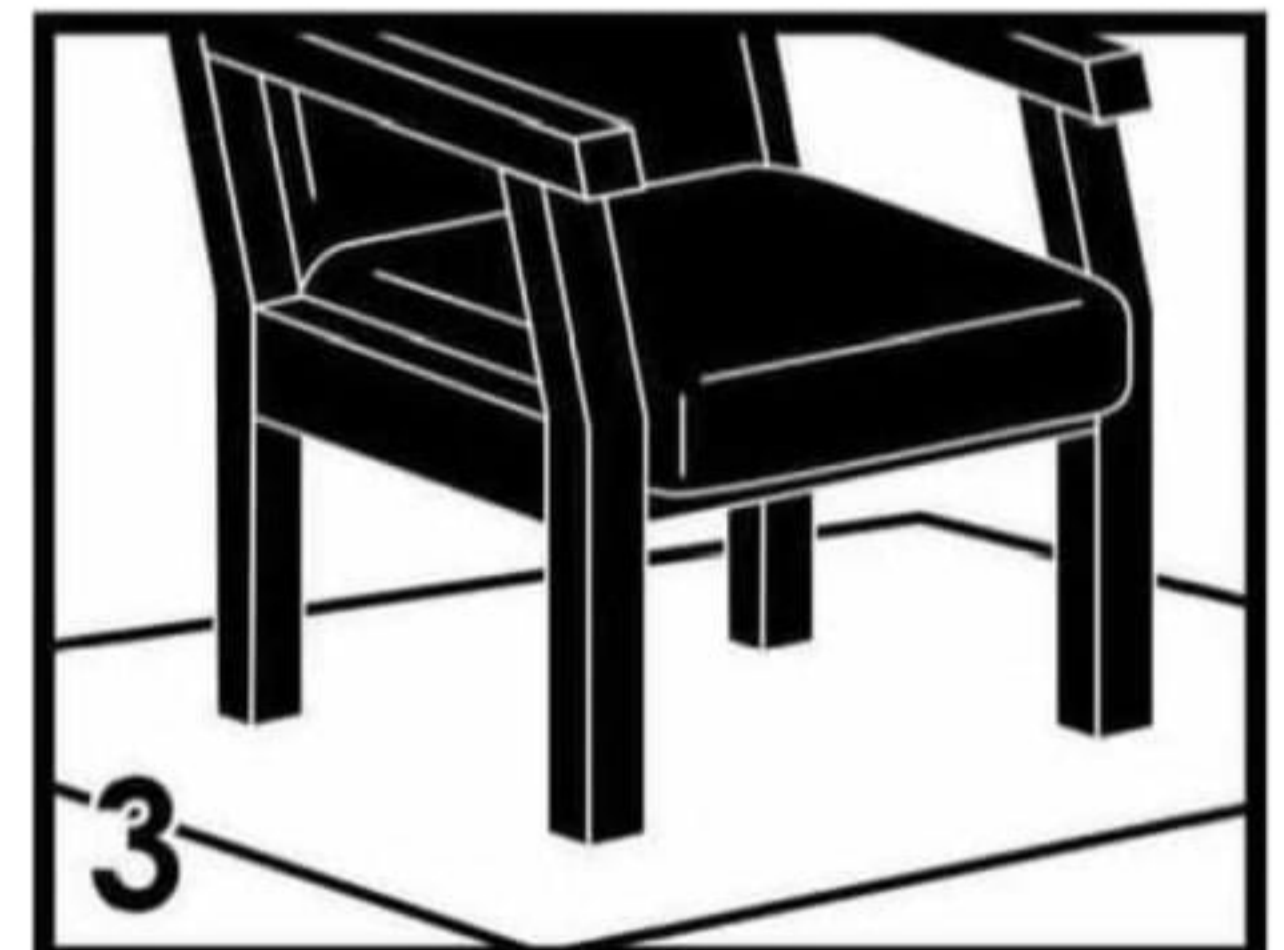

Use cardboard or carpet area when assembling furniture to prevent scratches. Make sure the furniture rests on a flat and level surface with each leg evenly touching the floor.

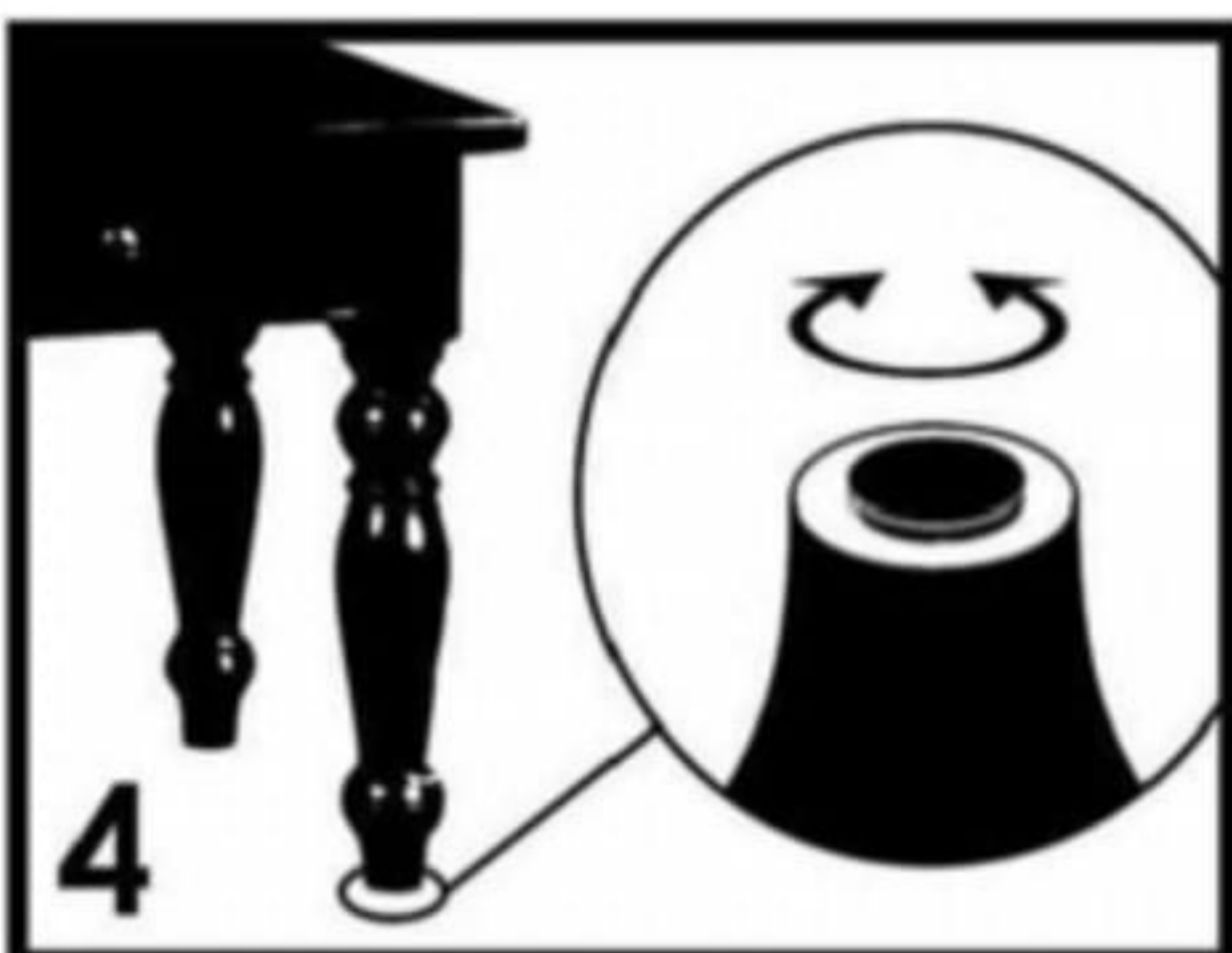

Some furniture comes with height adjustment knobs underneath each leg. To lower or to raise each leg, you need to turn clockwise or counterclockwise, respectively.

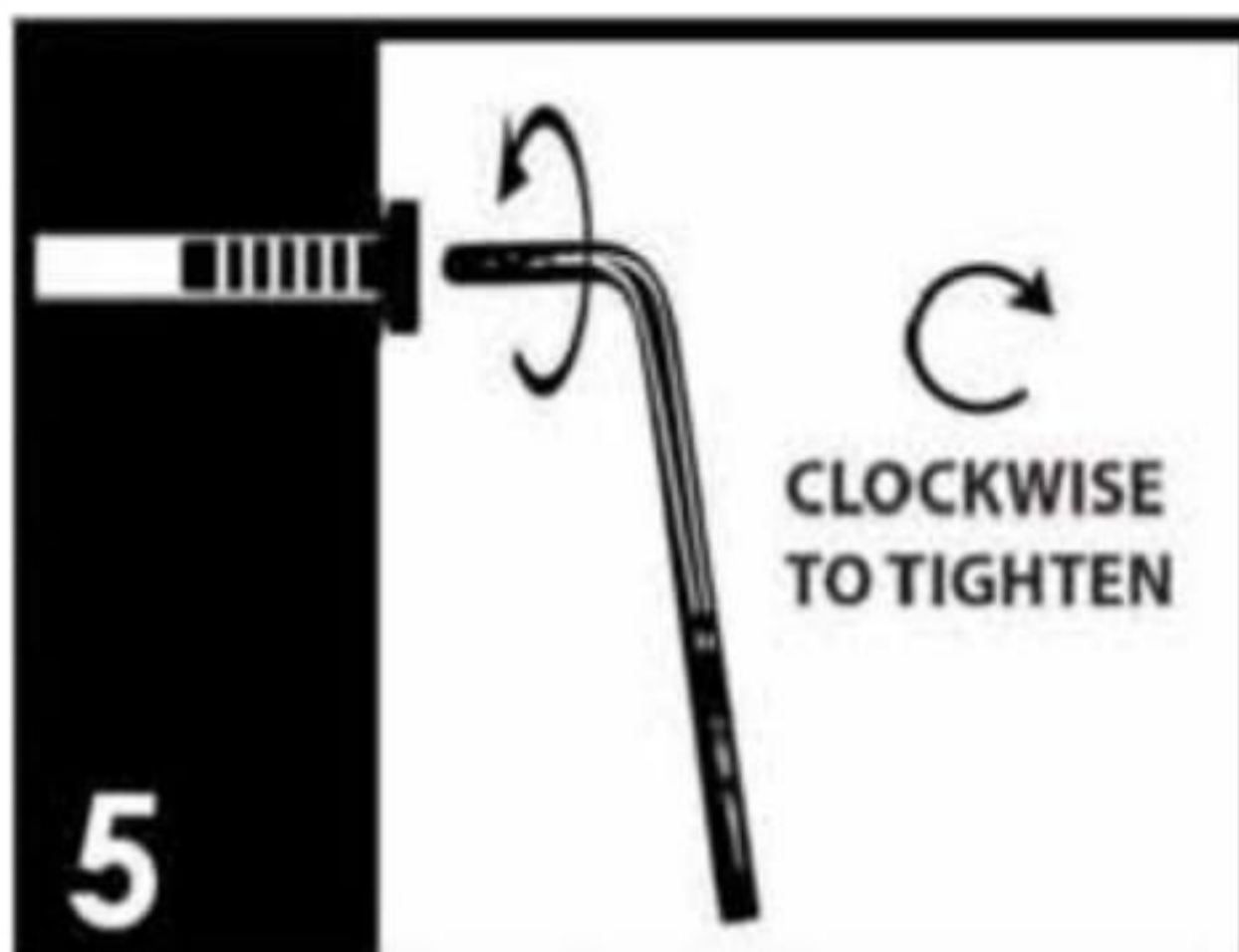

Make sure all parts are properly aligned, then use the appropriate hand tool to completely tighten the bolts or screws. Do not use power tools and do not overtighten.

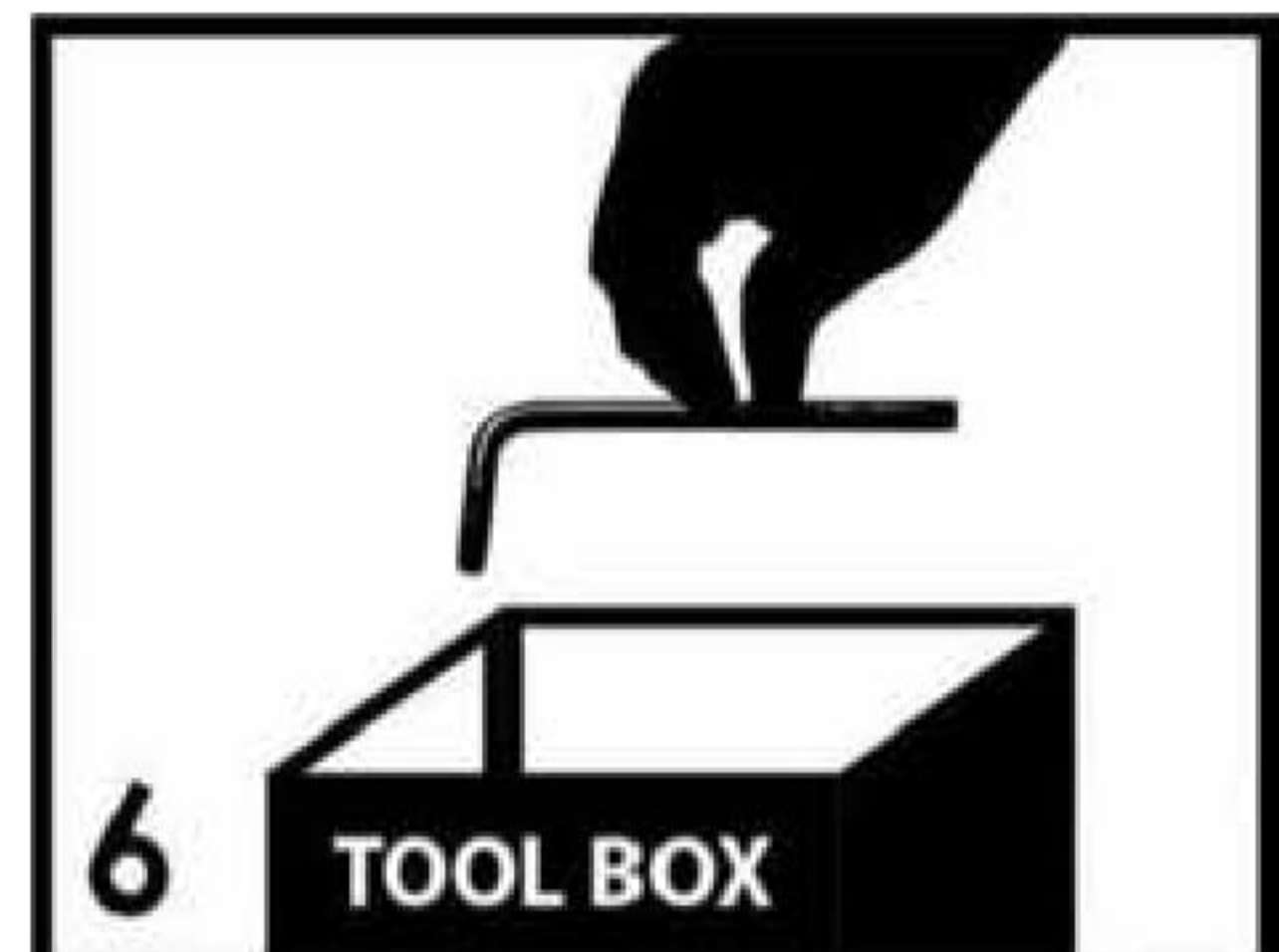

Save the instructions and store the Allen wrench or any supplied tool for later maintenance. After two weeks, check and tighten any loose hardware and repeat again every six months thereafter.

IT IS THE USER'S RESPONSIBILITY TO MAINTAIN THE FURNITURE. THE HARDWARE MAY LOOSEN OVER TIME AND MAY CAUSE THE FURNITURE TO BE WOBBLY AND UNABLE TO SUPPORT ITS INTENDED WEIGHT CAPACITY. THIS MAY LEAD TO COLLAPSE AND MAY CAUSE SERIOUS INJURY.



FAILURE TO FOLLOW THE GUIDELINES ABOVE MAY RESULT IN INJURY AND/OR PROPERTY DAMAGE.



Before you begin, please read Page 2 of "Assembly and Care Advice".

And remember, do not tighten until each step is completed or instructed.

Parts List

Hardware List

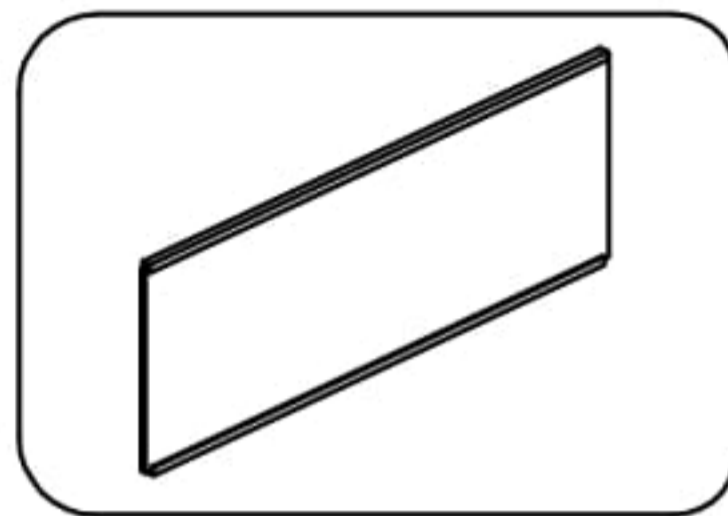

#1 x 1pc
Headboard

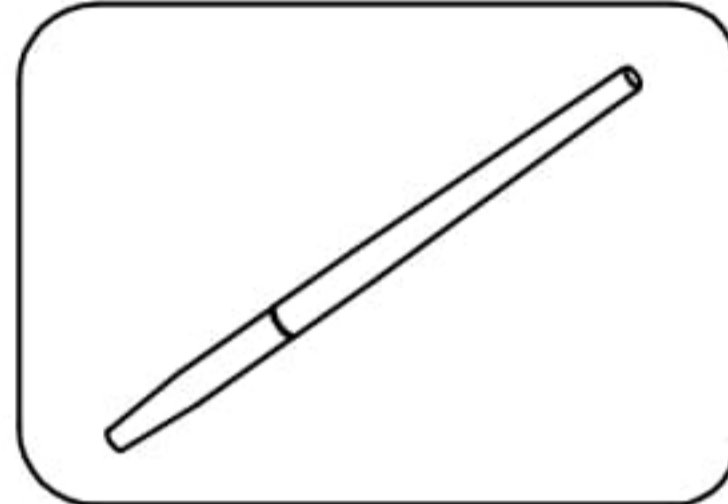

#2 x 2pcs
Headboard Leg (L&R)

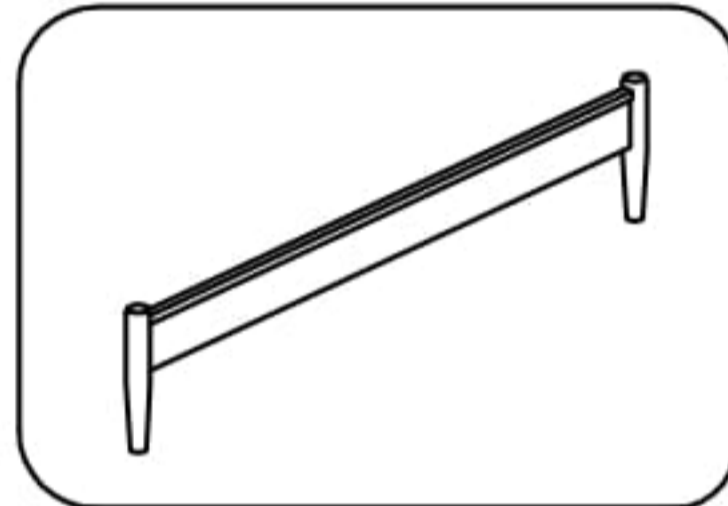

#3 x 1pc
Footboard

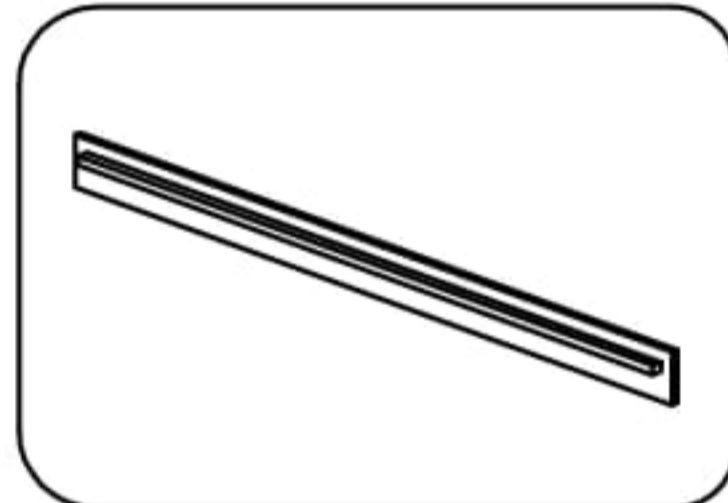

#4 x 2pcs
Side Rail

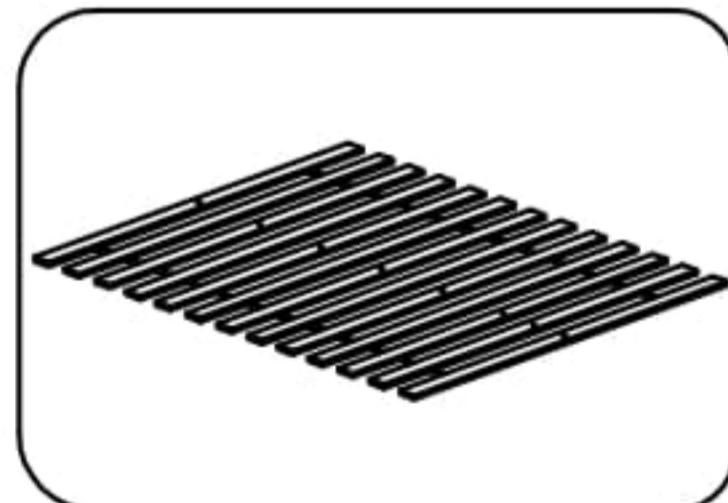

#5 x 1Set (13pcs)
Bed Slat

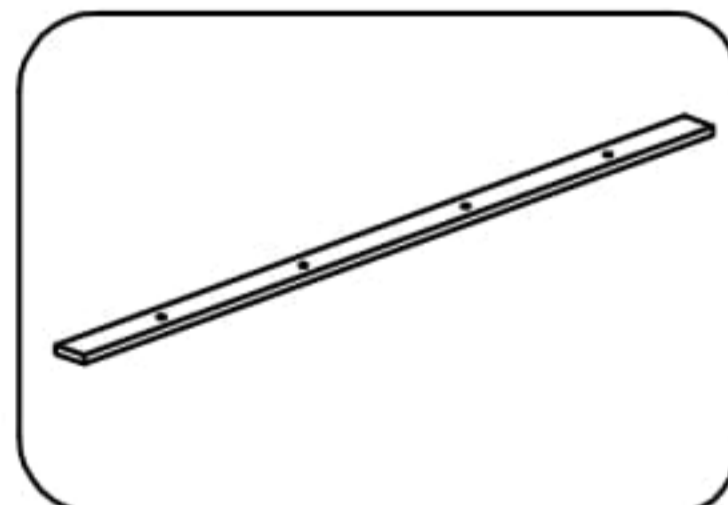

#6 x 1pc
Center Rail

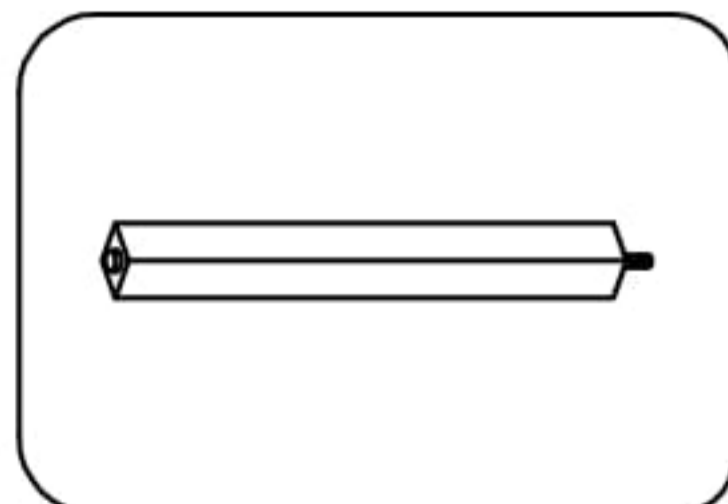

#7 x 4pcs $\varnothing\frac{5}{16}$ "
Support Leg (310x30x30mm)

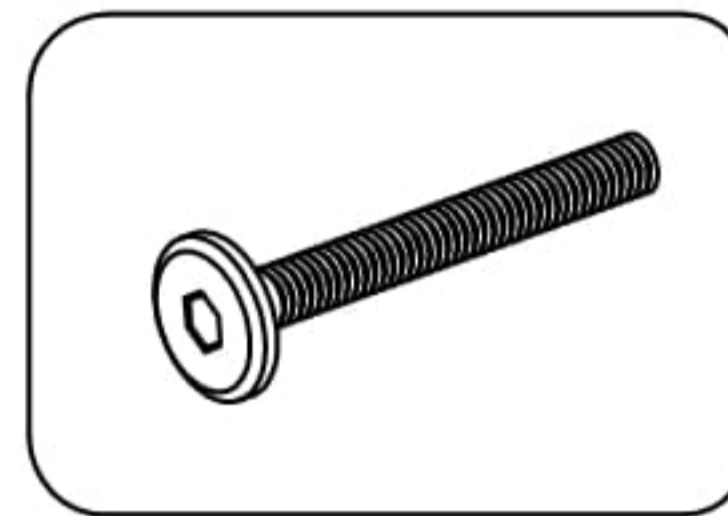

#A x 16pcs
Bolt $\varnothing\frac{1}{4}$ " x 1- $\frac{3}{8}$ "

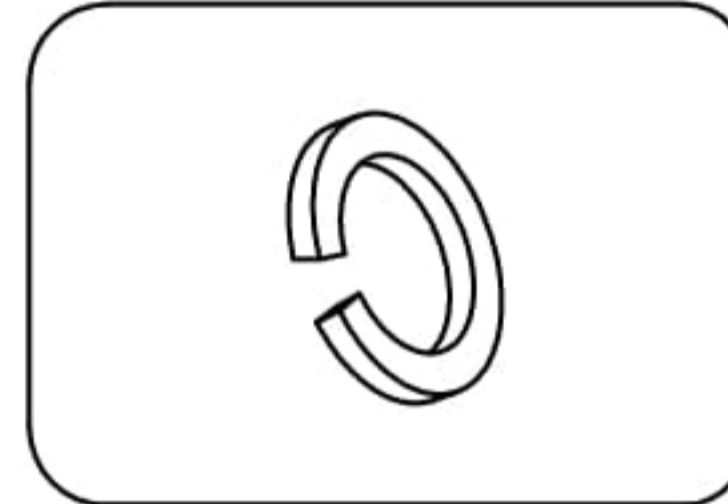

#B x 16pcs
Lock washer $\varnothing\frac{1}{4}$ "

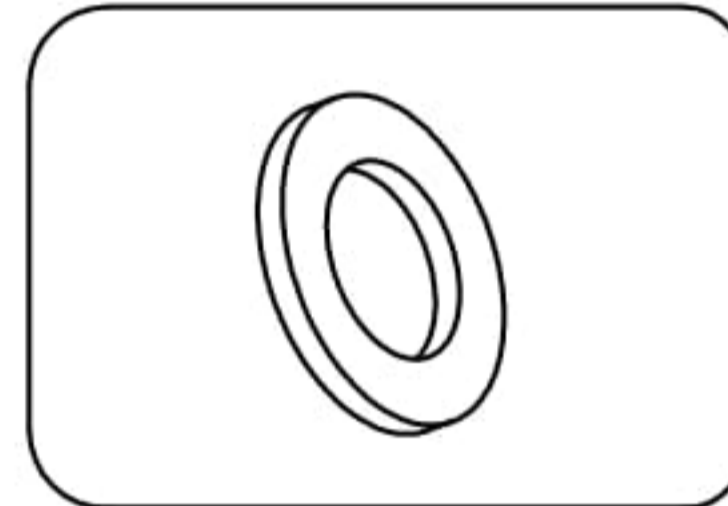

#C x 6pcs
Flat washer $\varnothing\frac{1}{4}$ "- $\frac{3}{4}$ "

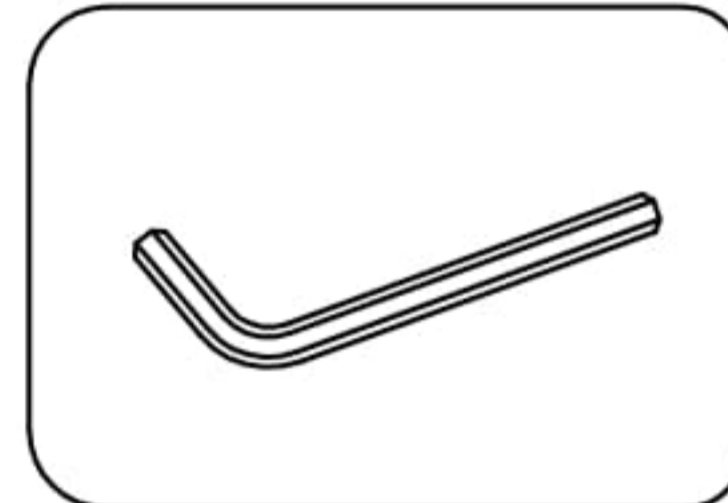

#D x 1pc
Allen wrench M4

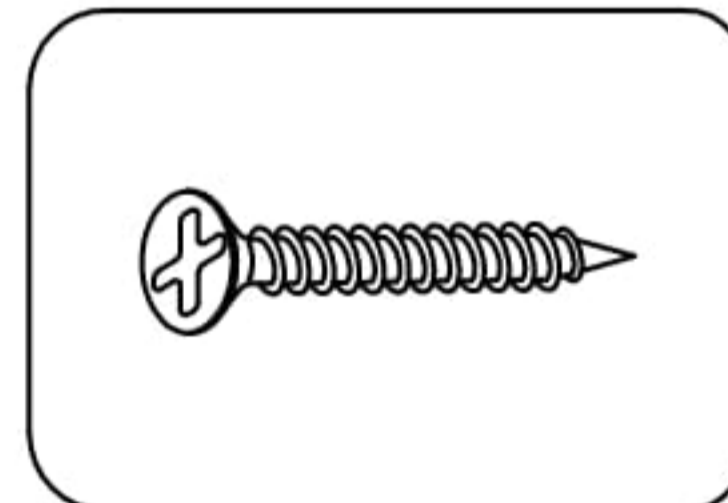

#E x 12pcs
Screw $\frac{5}{32}$ "x1- $\frac{3}{16}$ "

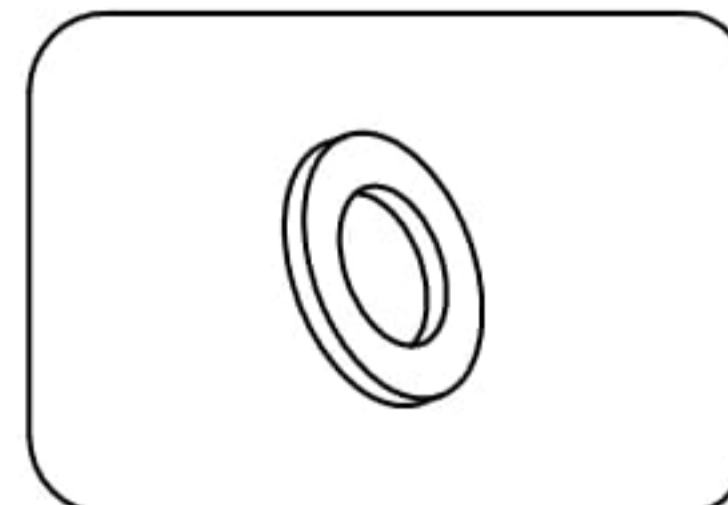

#F x 10pcs
Flat washer $\varnothing\frac{1}{4}$ "- $\frac{1}{2}$ "

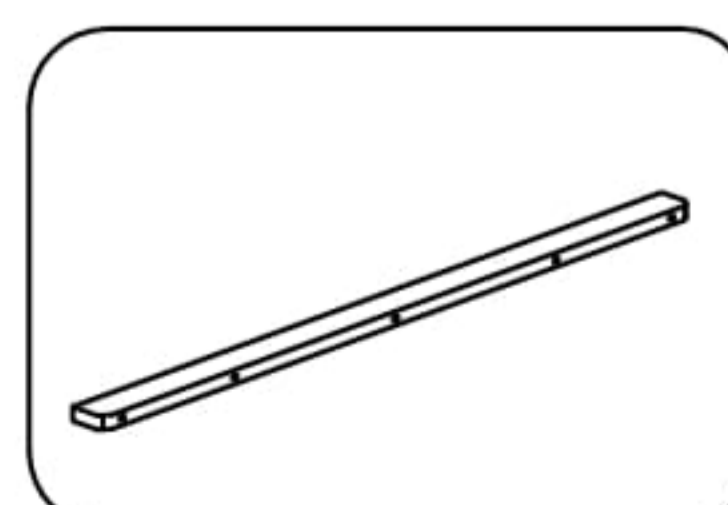

#8 x 2pcs
Side Rail Top Panel



#A x 6pcs
 #B x 6pcs
 #C x 6pcs

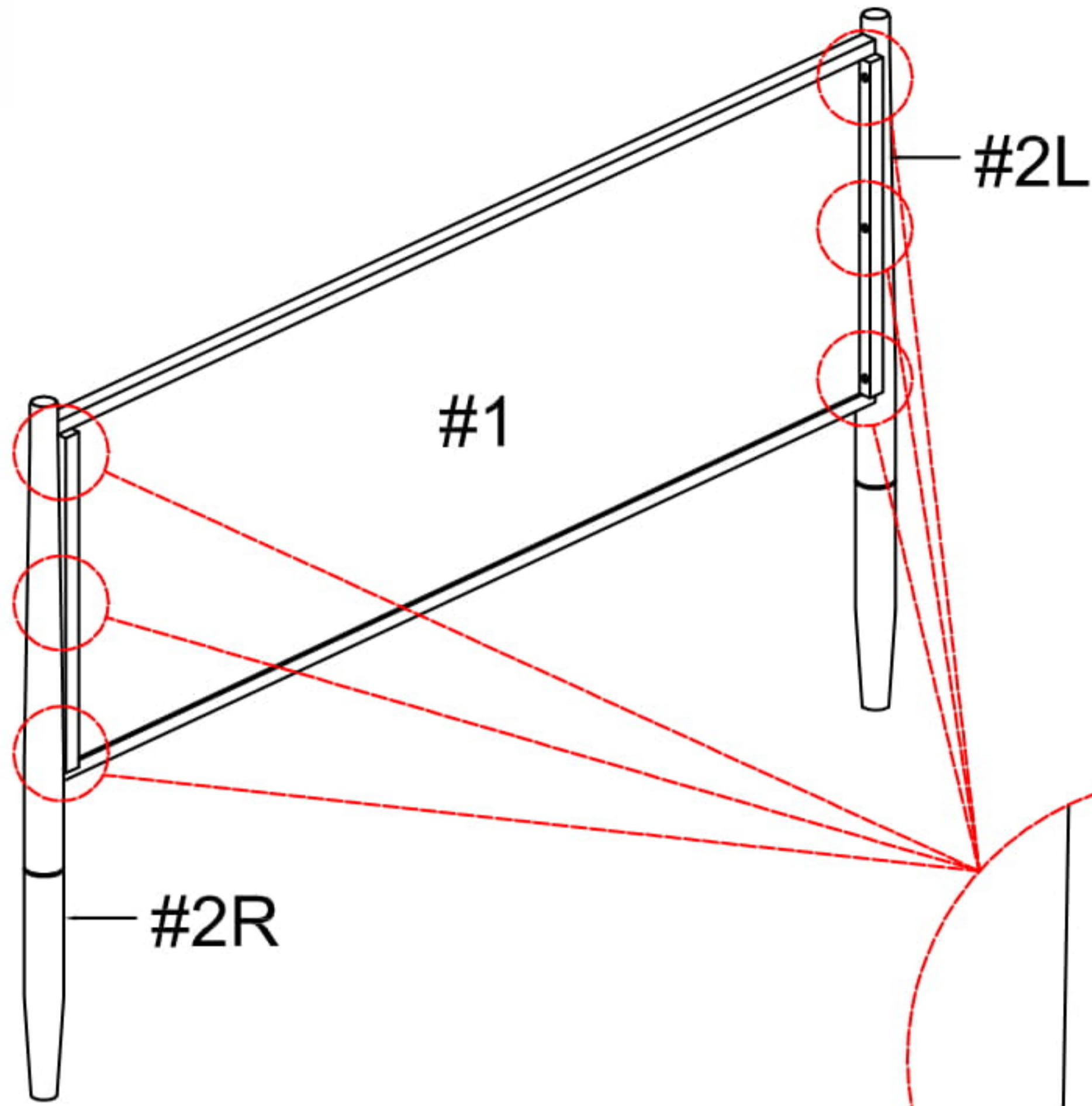

1. Prepare 6 bolt assemblies by first inserting a lock washer (#B) onto the bolt (#A) then a flat washer (#C) onto that same bolt (#A).

2. Align the legs (#2) to the holes along the side of the headboard (#1), then insert the bolts and secure.

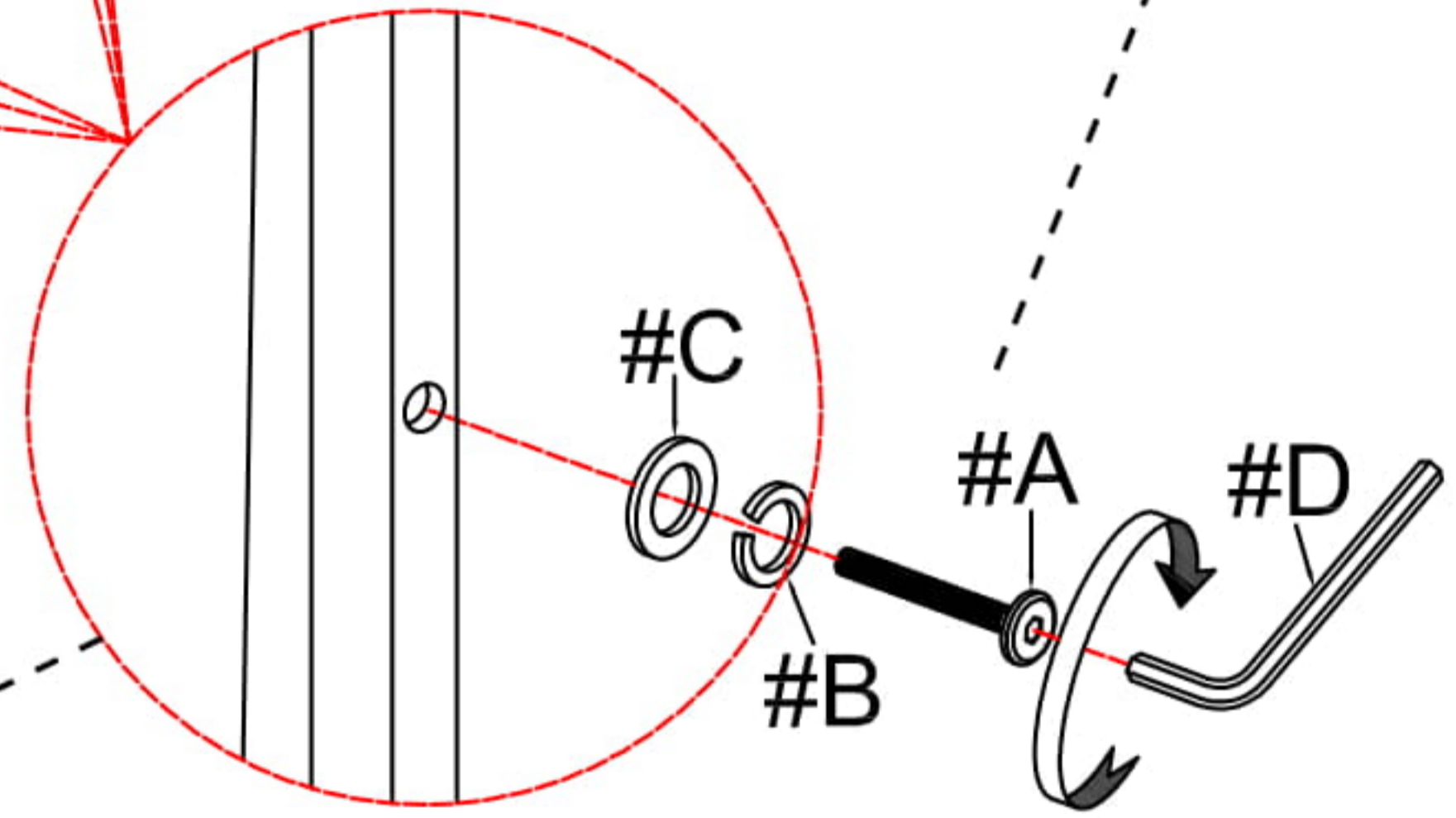

Hook each end of the side rails (#4) onto the slots along the headboard (#1) and foot board (#3).

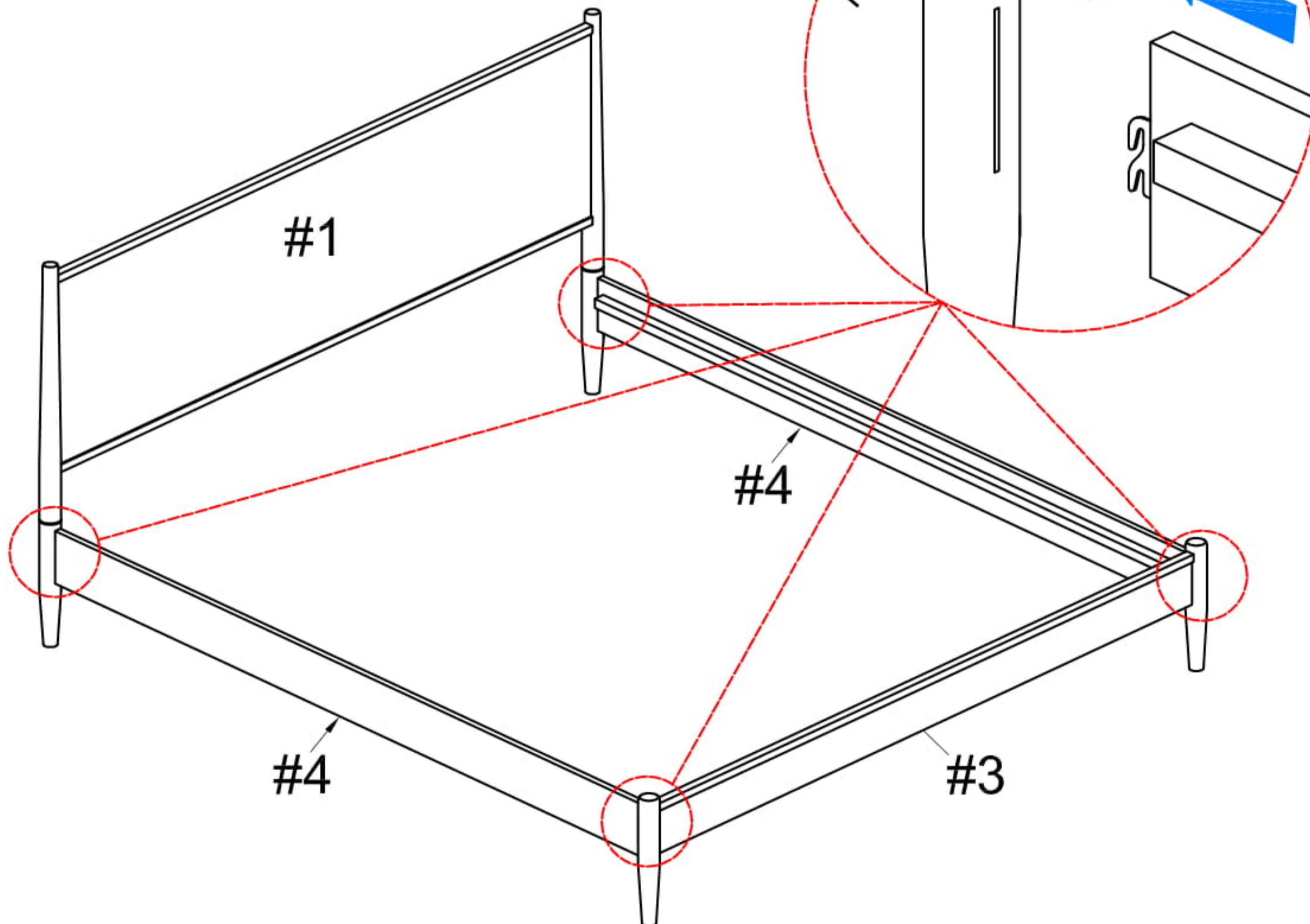

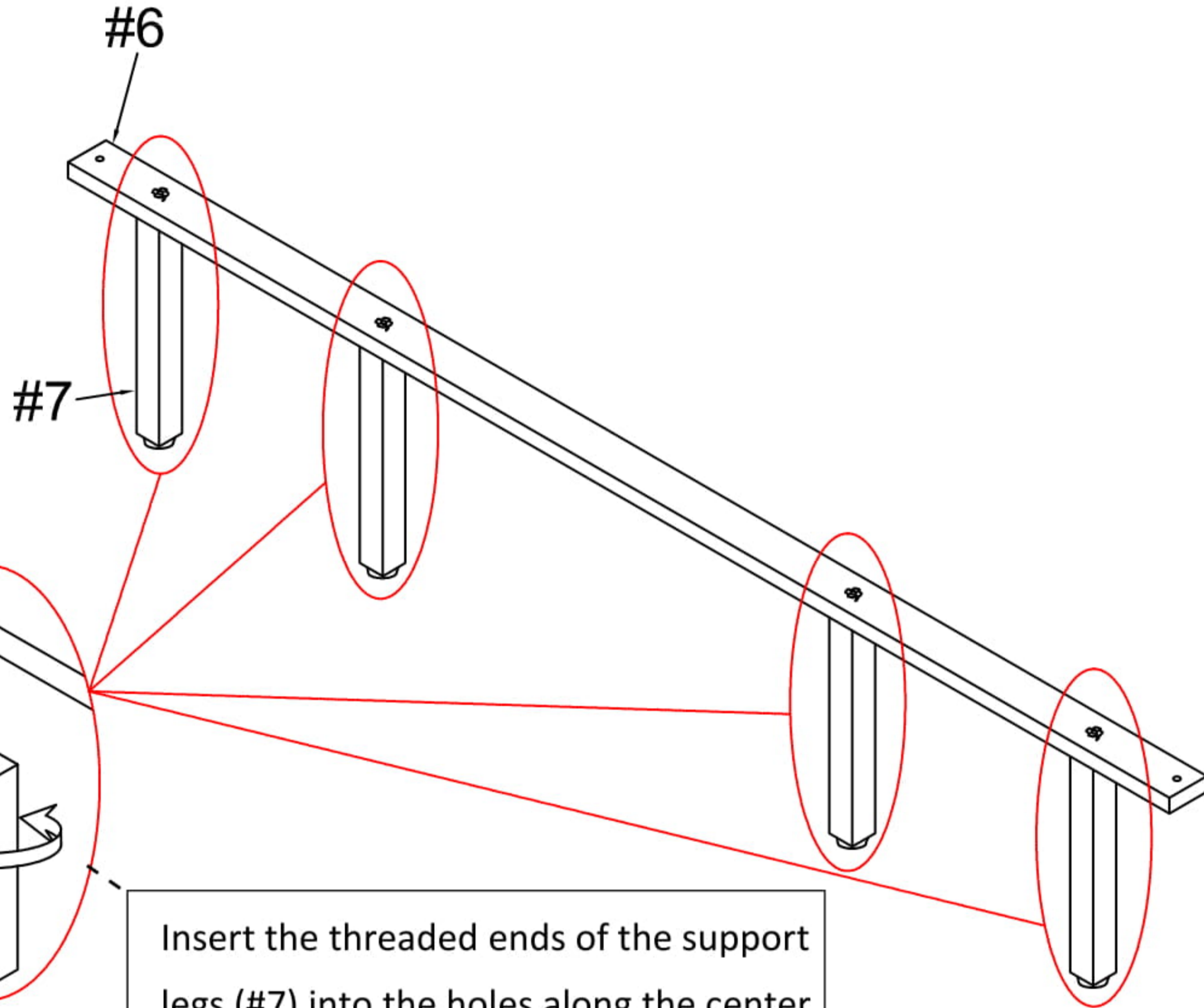

Insert the threaded ends of the support legs (#7) into the holes along the center rail (#6), turn right to tighten.

Adjust according to the ground level.



#E x 12pcs

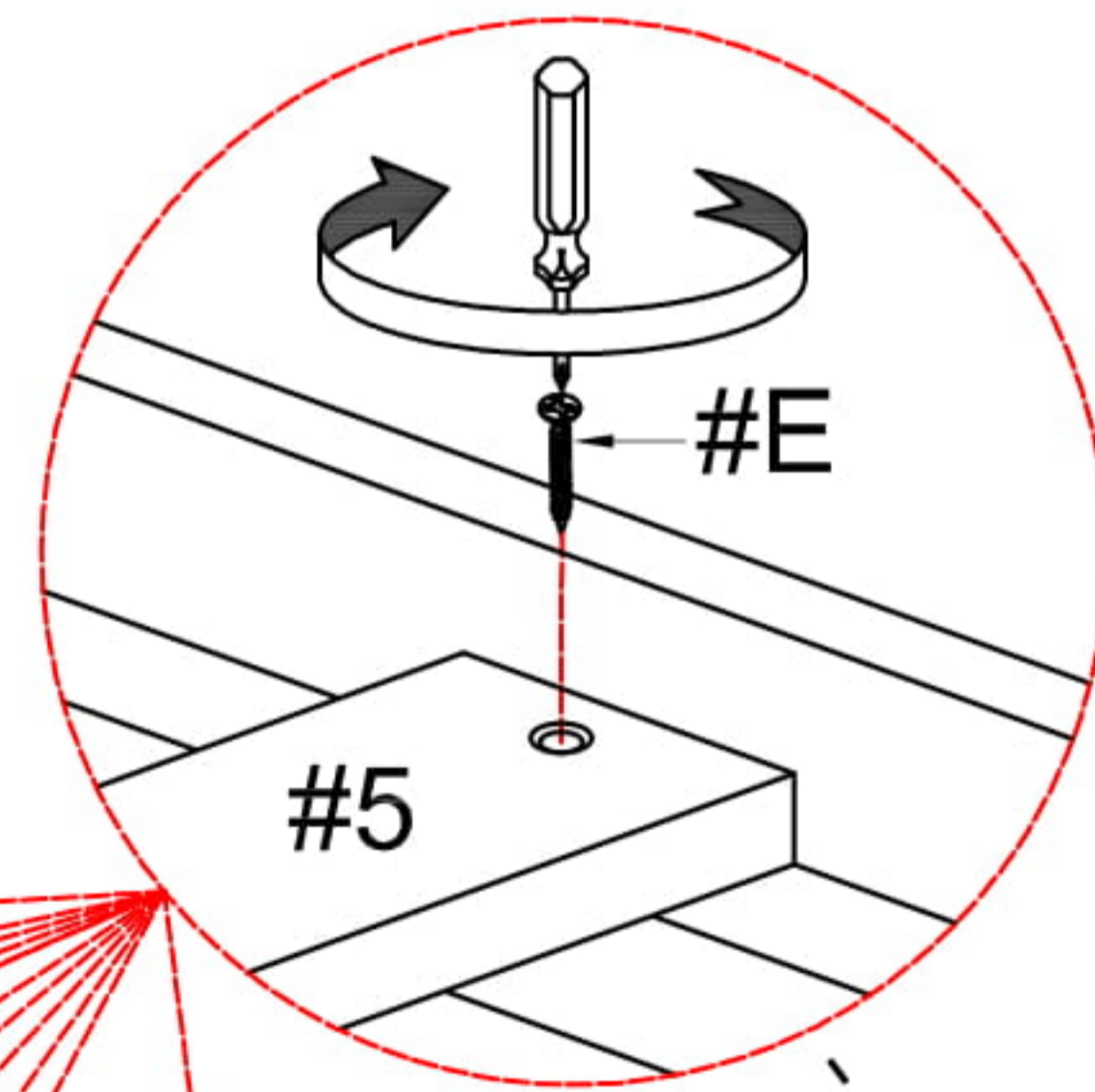
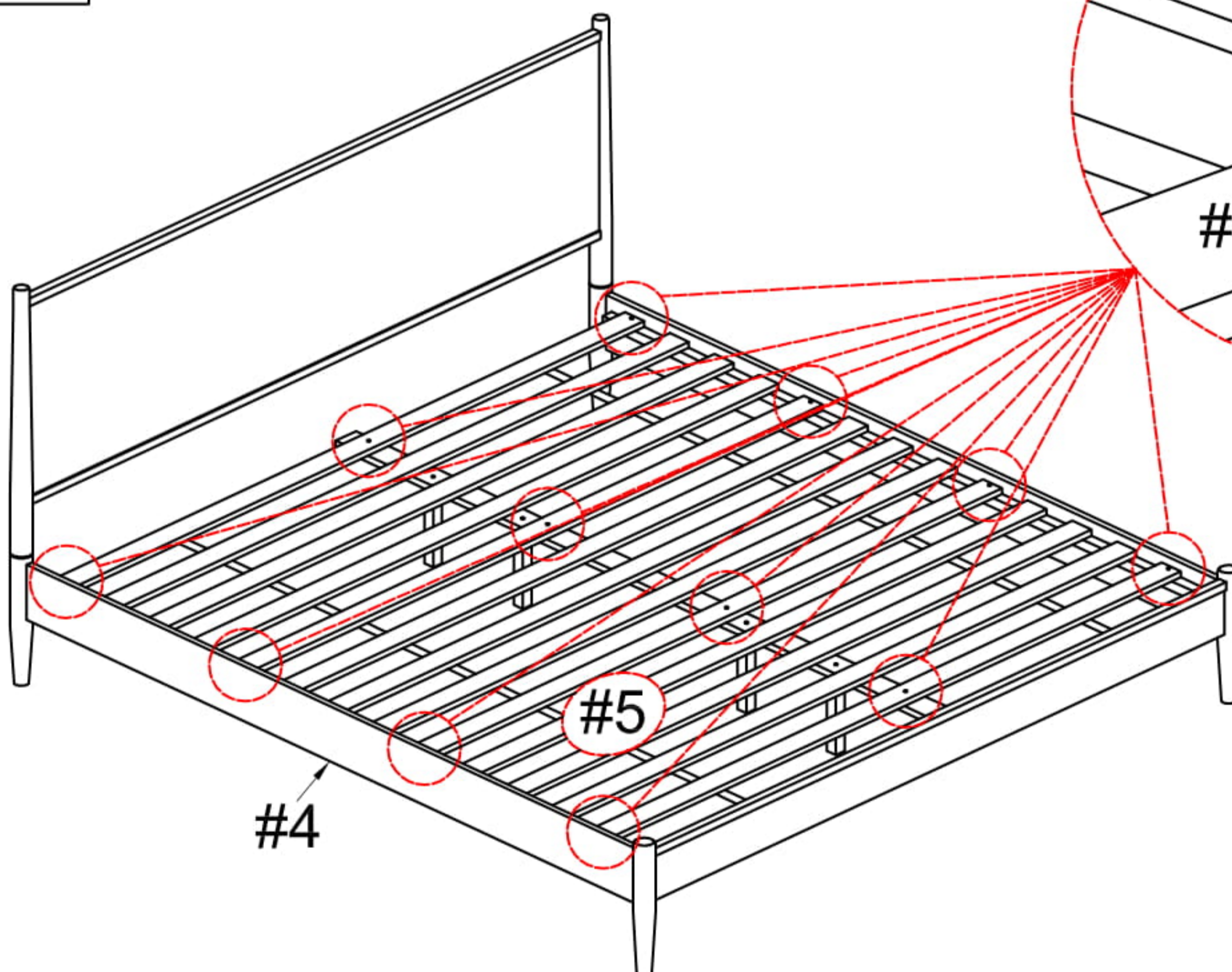

Place the bed slats (#5) onto the rails, then insert a screw (#E) into each hole. Secure using a screwdriver.

Assembly Instructions

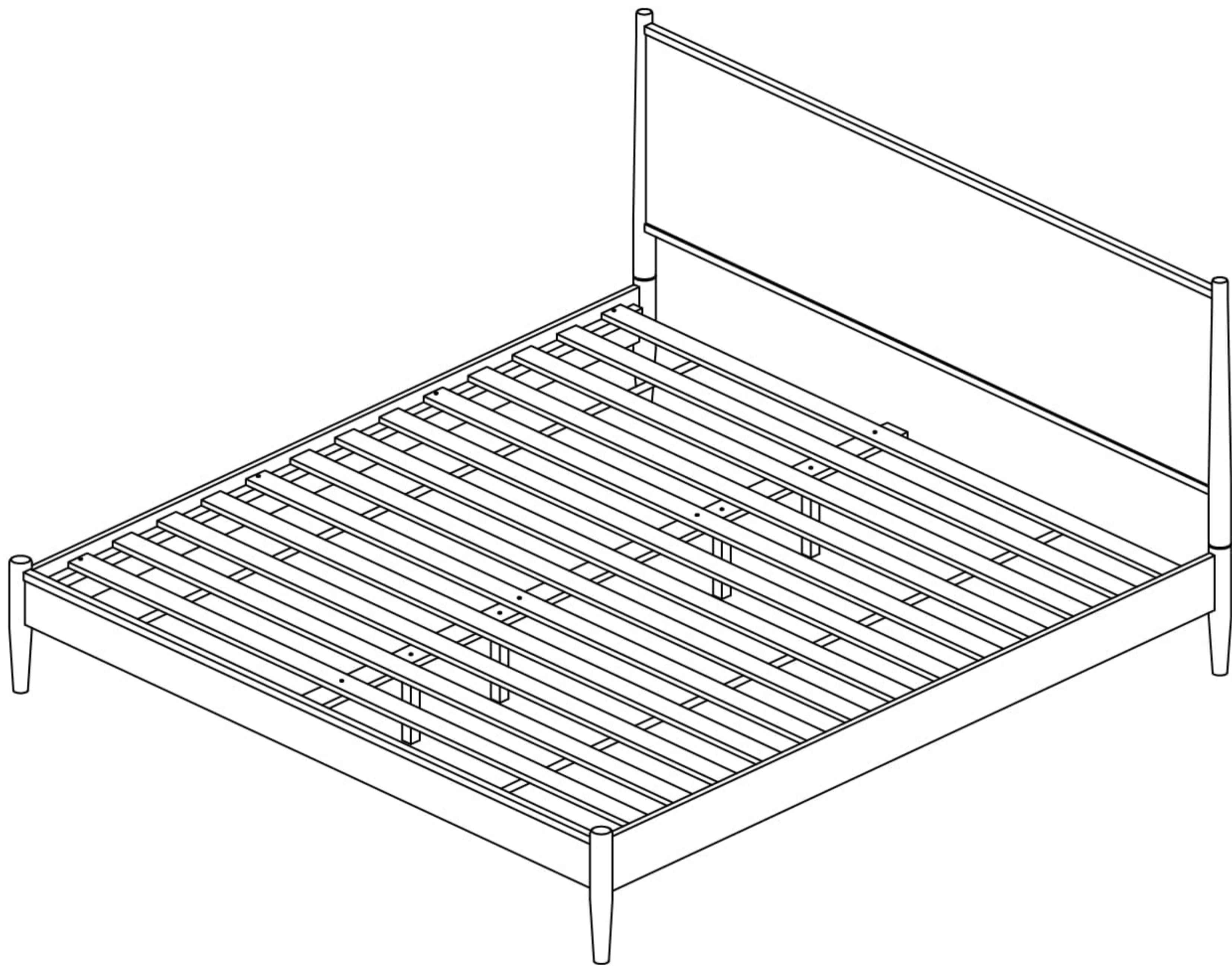

ASSEMBLY RATING

The Assembly Rating is a 5-point system that shows the degree of effort needed in assembling a specific product (with 1 being easy and 5 being difficult). For some products, two persons are recommended.

Tools Required For Assembly:

Allen Wrench

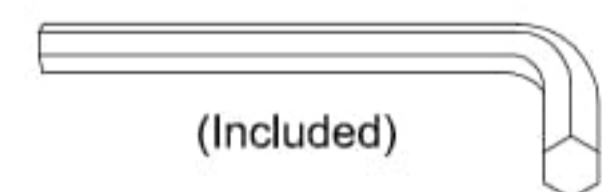

Phillips Screwdriver

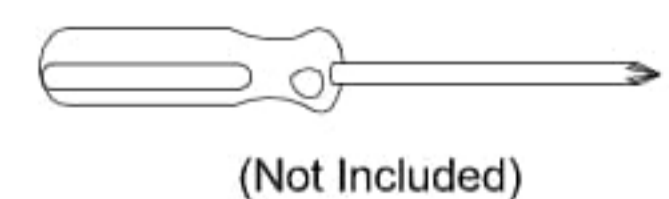

EASY  DIFFICULT



2 PERSONS RECOMMENDED

ASSEMBLY & CARE ADVICE

FOR YOUR FURNITURE TO LAST, CORRECT ASSEMBLY AND PROPER MAINTENANCE ARE NECESSARY. PLEASE FOLLOW THE INFORMATION PROVIDED BELOW TO FULLY ENJOY YOUR FURNITURE.

BASIC ASSEMBLY TECHNIQUES

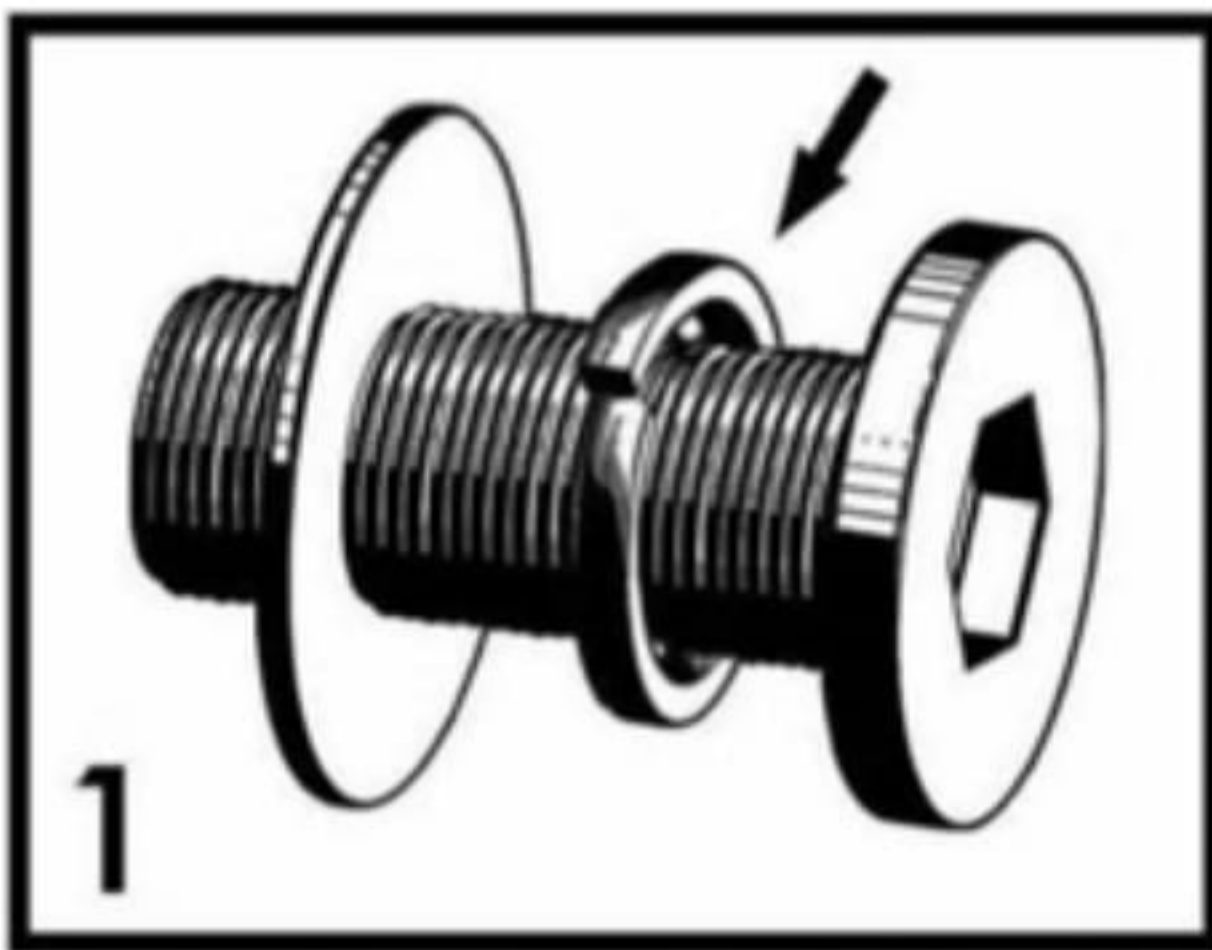

When lock or spring washer is used in an assembly, please make sure the lock or spring washer is placed between the larger flat washer and the head of the screw or bolt.



Position each part correctly and insert screws or bolts into their respective holes by hand tighten or using the proper hand tool. Only tighten when step is completed or when instructed to do so.

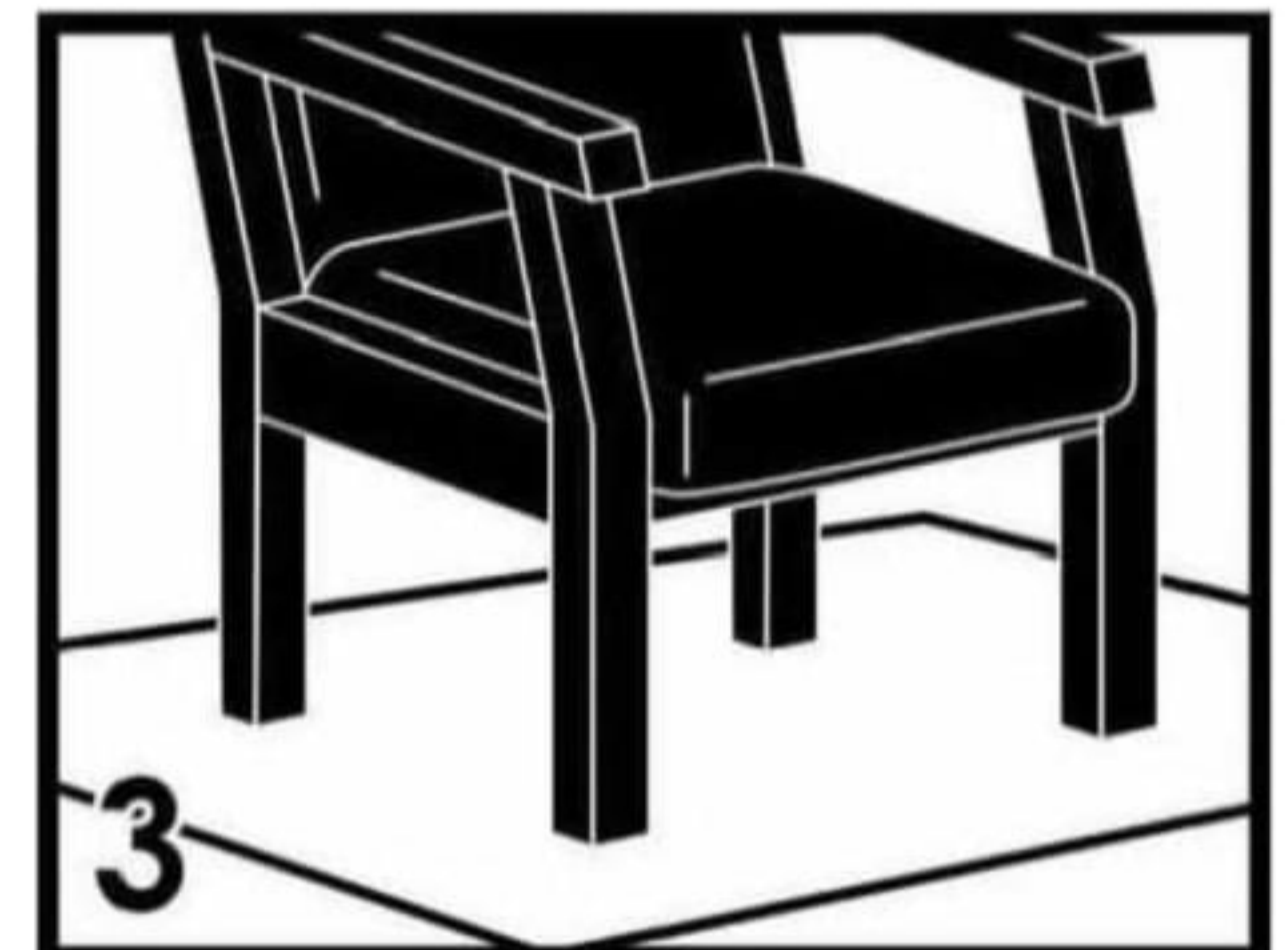

Use cardboard or carpet area when assembling furniture to prevent scratches. Make sure the furniture rests on a flat and level surface with each leg evenly touching the floor.

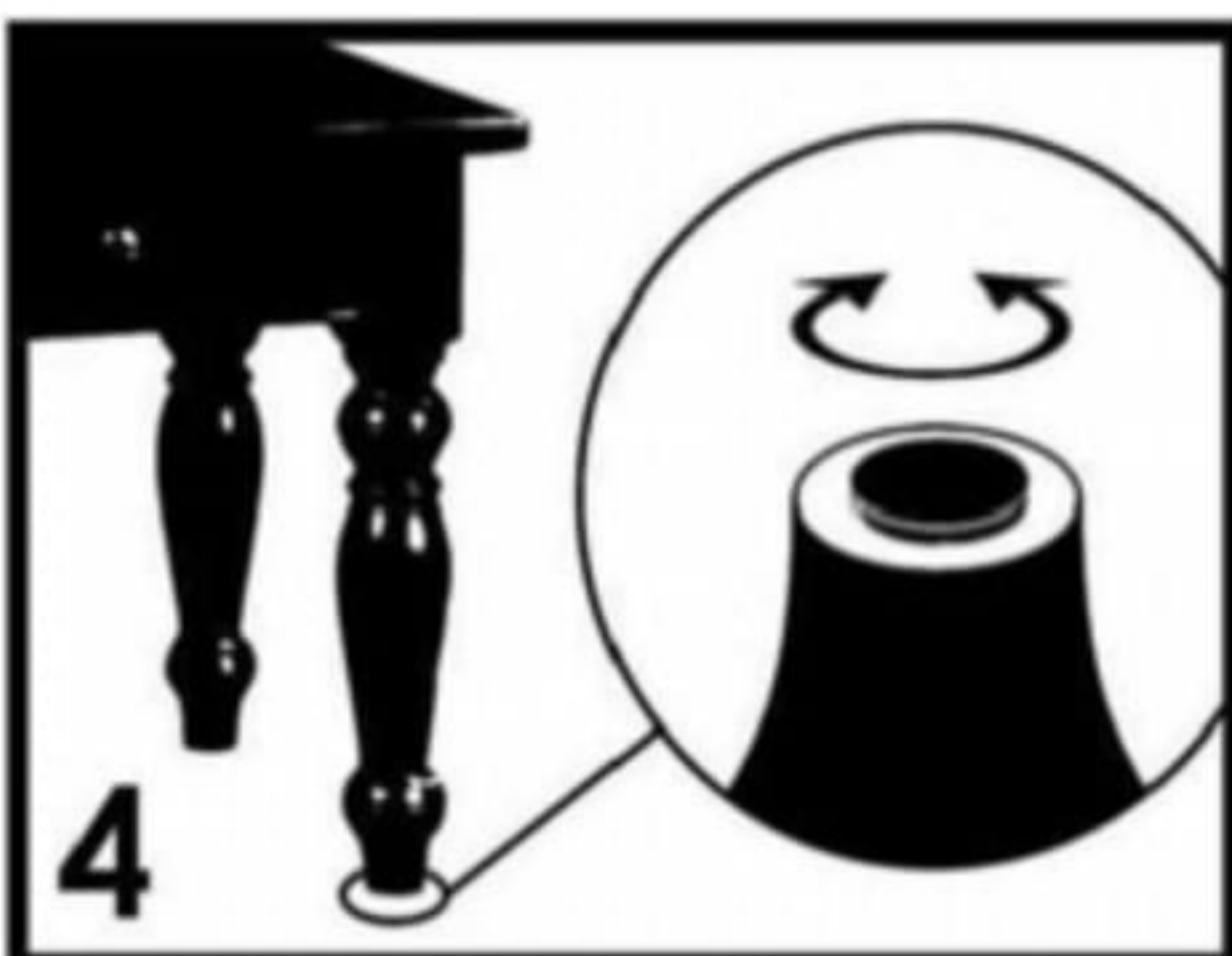

Some furniture comes with height adjustment knobs underneath each leg. To lower or to raise each leg, you need to turn clockwise or counterclockwise, respectively.

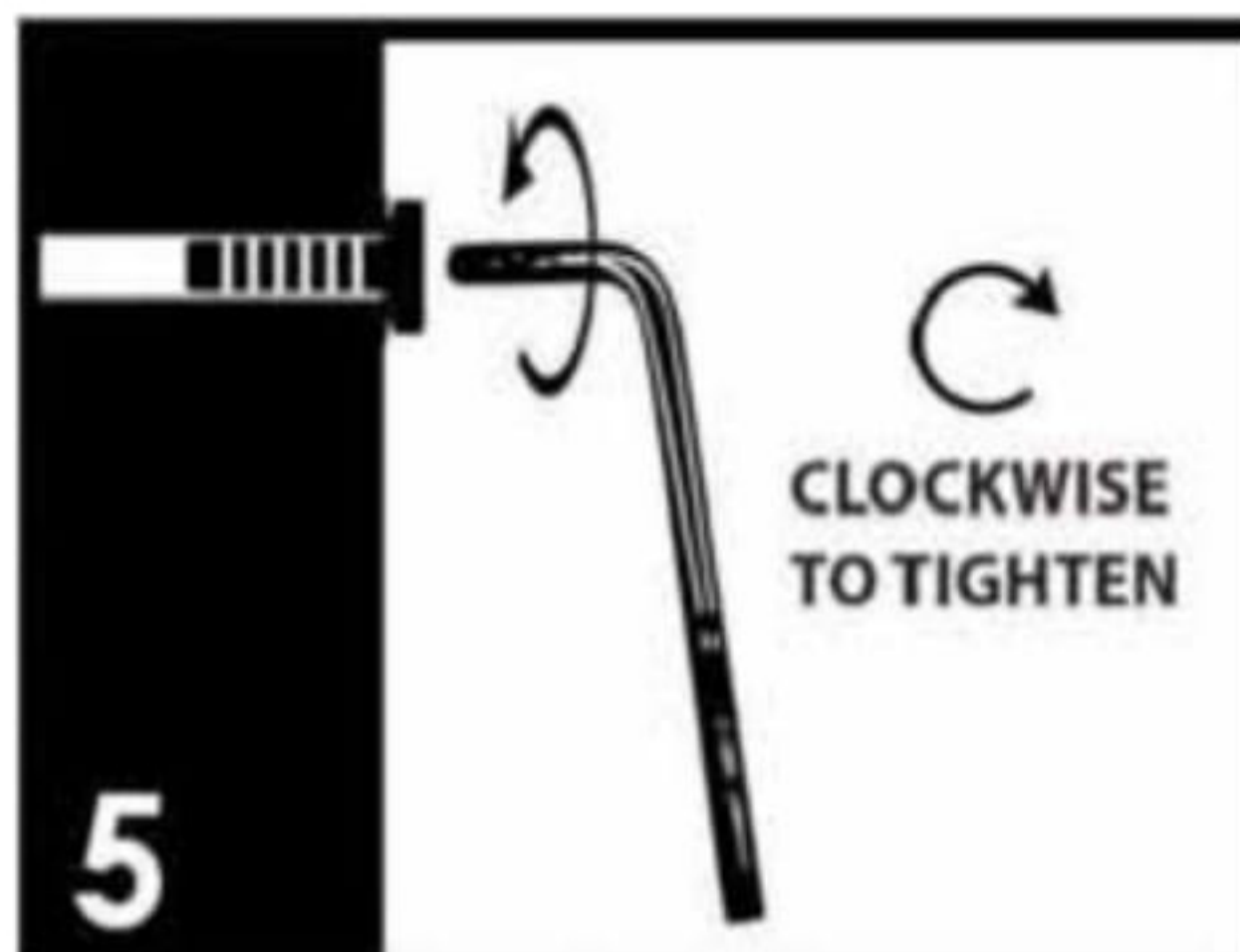

Make sure all parts are properly aligned, then use the appropriate hand tool to completely tighten the bolts or screws. Do not use power tools and do not overtighten.



Save the instructions and store the Allen wrench or any supplied tool for later maintenance. After two weeks, check and tighten any loose hardware and repeat again every six months thereafter.

IT IS THE USER'S RESPONSIBILITY TO MAINTAIN THE FURNITURE. THE HARDWARE MAY LOOSEN OVER TIME AND MAY CAUSE THE FURNITURE TO BE WOBBLY AND UNABLE TO SUPPORT ITS INTENDED WEIGHT CAPACITY. THIS MAY LEAD TO COLLAPSE AND MAY CAUSE SERIOUS INJURY.



FAILURE TO FOLLOW THE GUIDELINES ABOVE MAY RESULT IN INJURY AND/OR PROPERTY DAMAGE.



Before you begin, please read Page 2 of "Assembly and Care Advice".

And remember, do not tighten until each step is completed or instructed.

Parts List

Hardware List

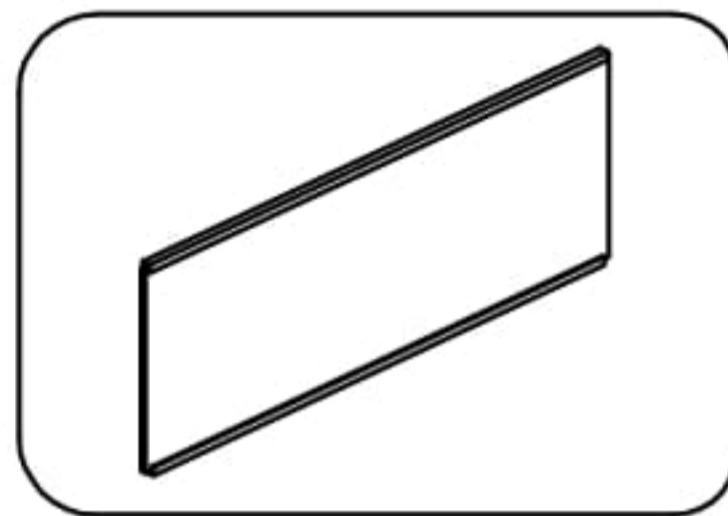

#1 x 1pc
Headboard

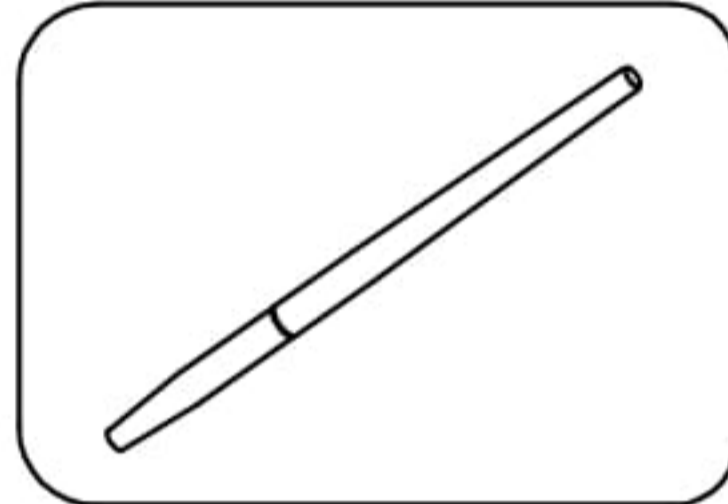

#2 x 2pcs
Headboard Leg (L&R)

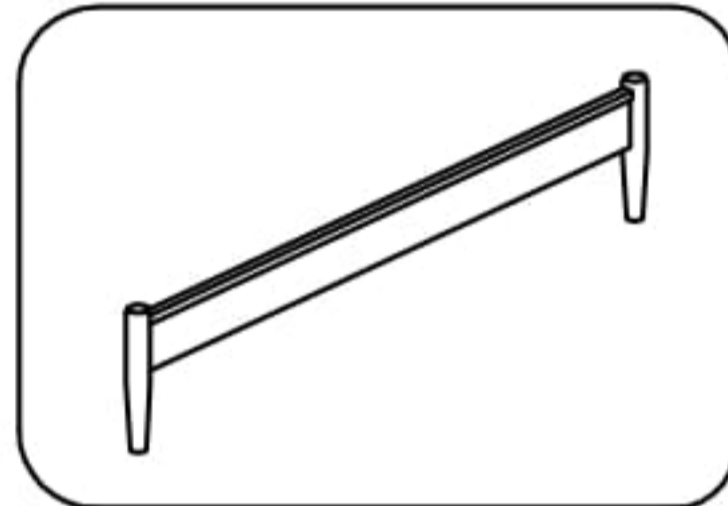

#3 x 1pc
Footboard

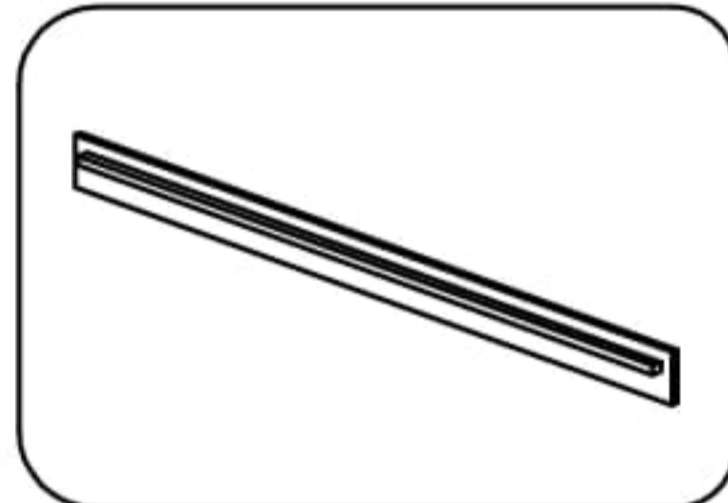

#4 x 2pcs
Side Rail

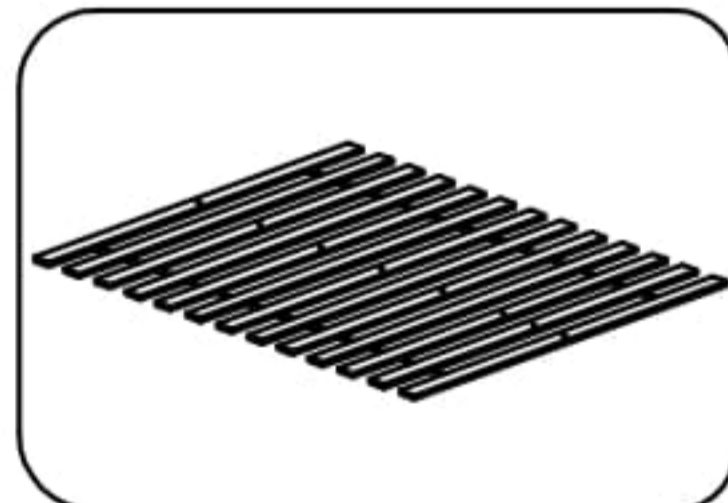

#5 x 1Set (13pcs)
Bed Slat

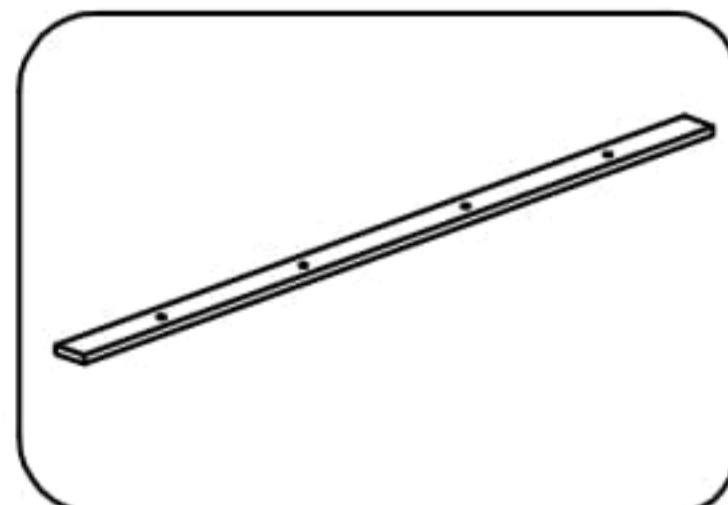

#6 x 1pc
Center Rail

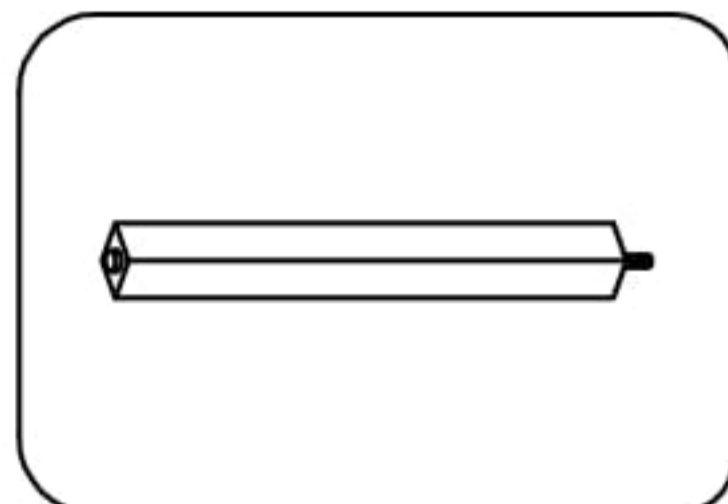

#7 x 4pcs $\varnothing \frac{5}{16}$ "
Support Leg (310x30x30mm)

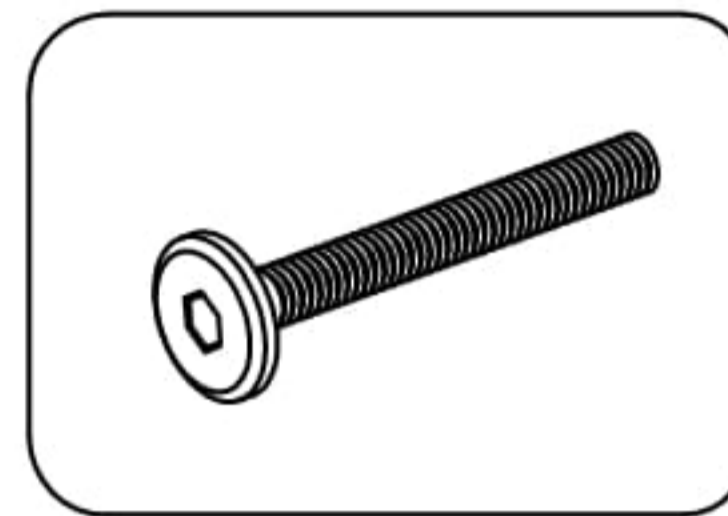

#A x 6pcs
Bolt $\varnothing 1/4$ " x 1-3/8"

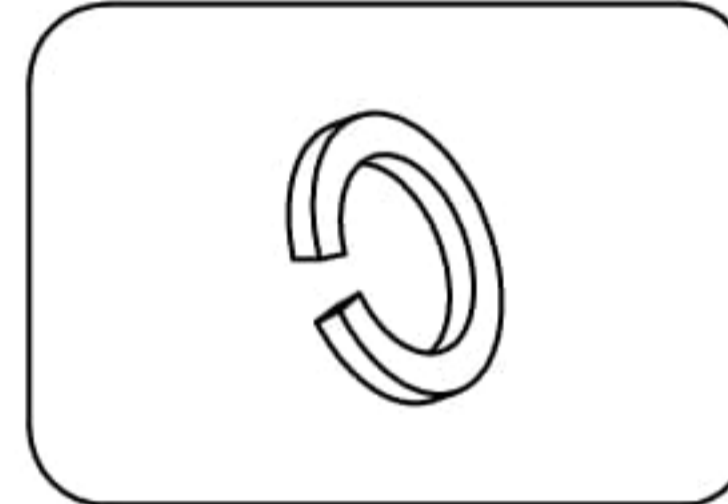

#B x 6pcs
Lock washer $\varnothing 1/4$ "

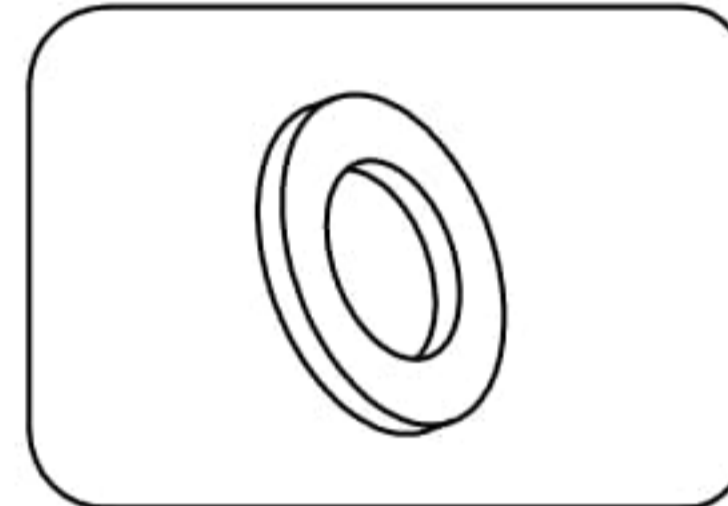

#C x 6pcs
Flat washer $\varnothing 1/4$ "-3/4"

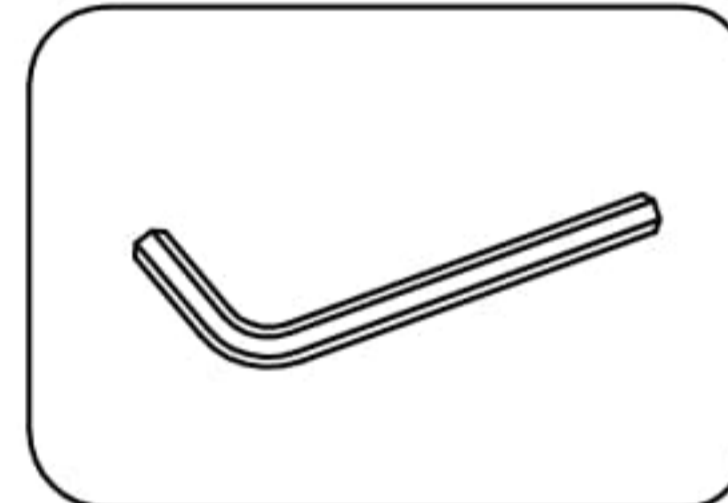

#D x 1pc
Allen wrench M4

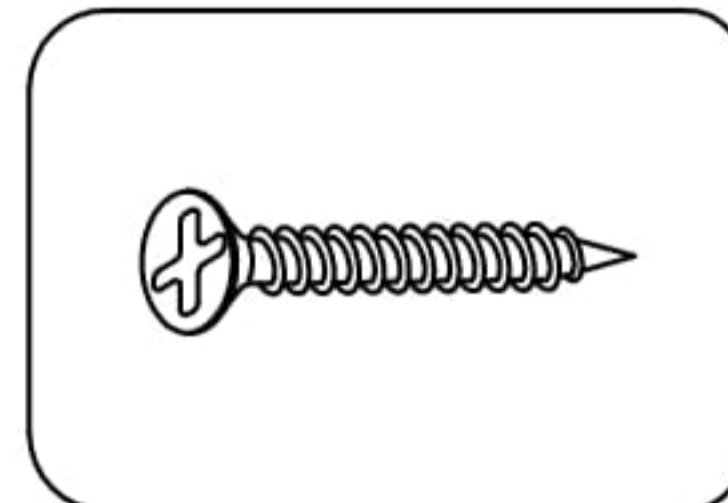

#E x 12pcs
Screw 5/32"x1-3/16"



#A x 6pcs
 #B x 6pcs
 #C x 6pcs

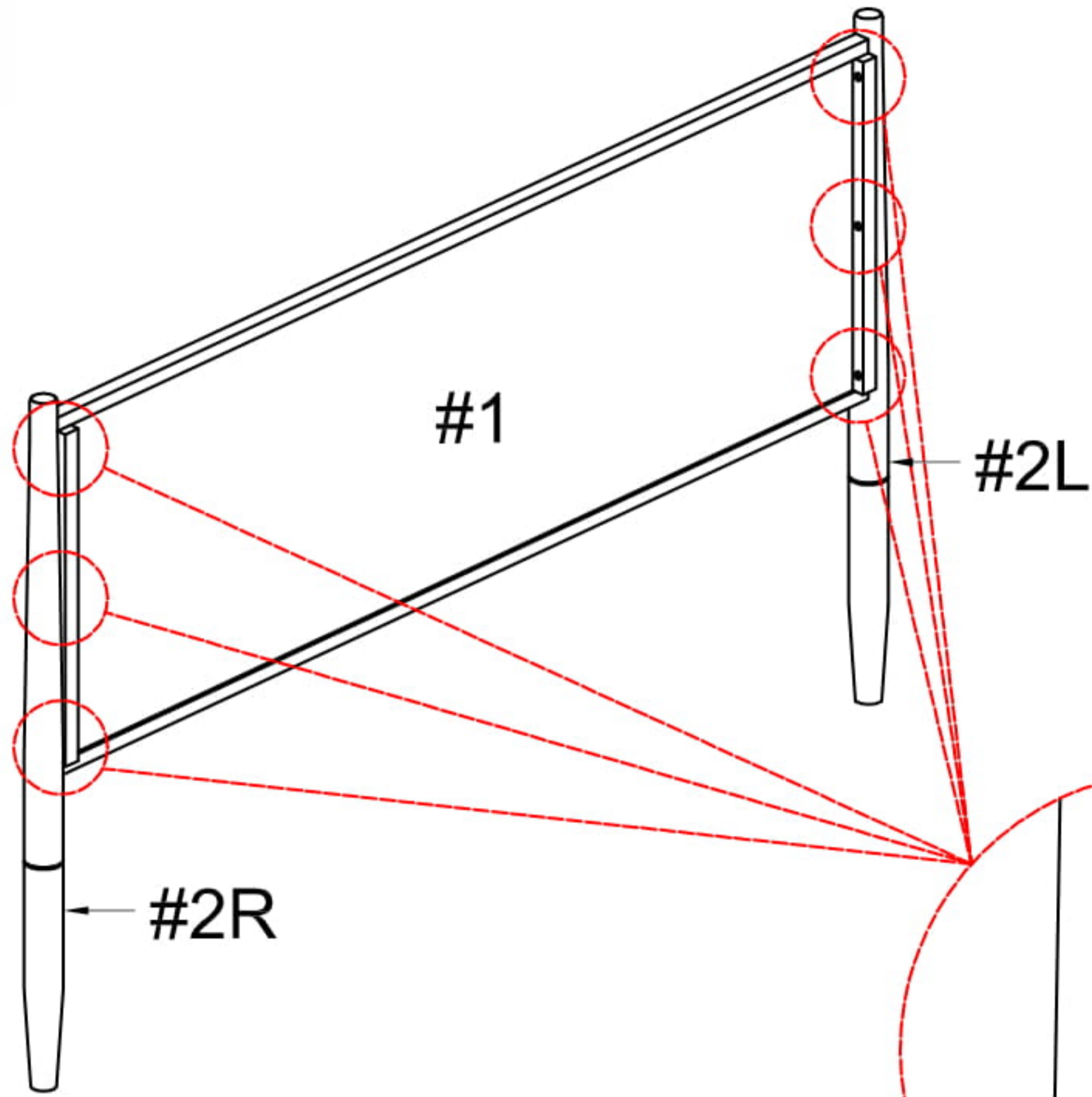

1. Prepare 6 bolt assemblies by first inserting a lock washer (#B) onto the bolt (#A) then a flat washer (#C) onto that same bolt (#A).

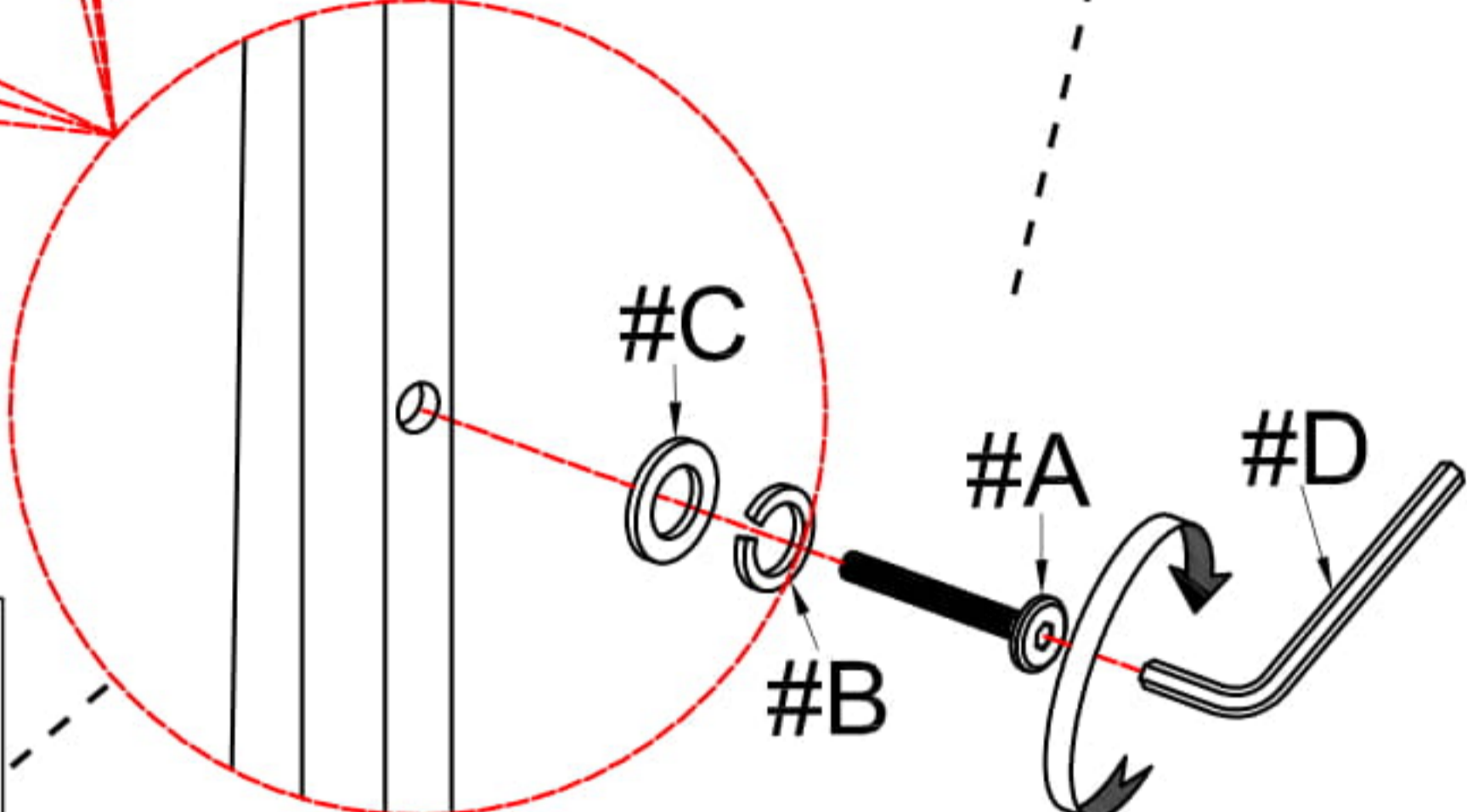

2. Align the legs (#2) to the holes along the side of the headboard (#1), then insert the bolts and secure.



Hook each end of the side rails (#4) onto the slots along the headboard (#1) and foot board (#3).

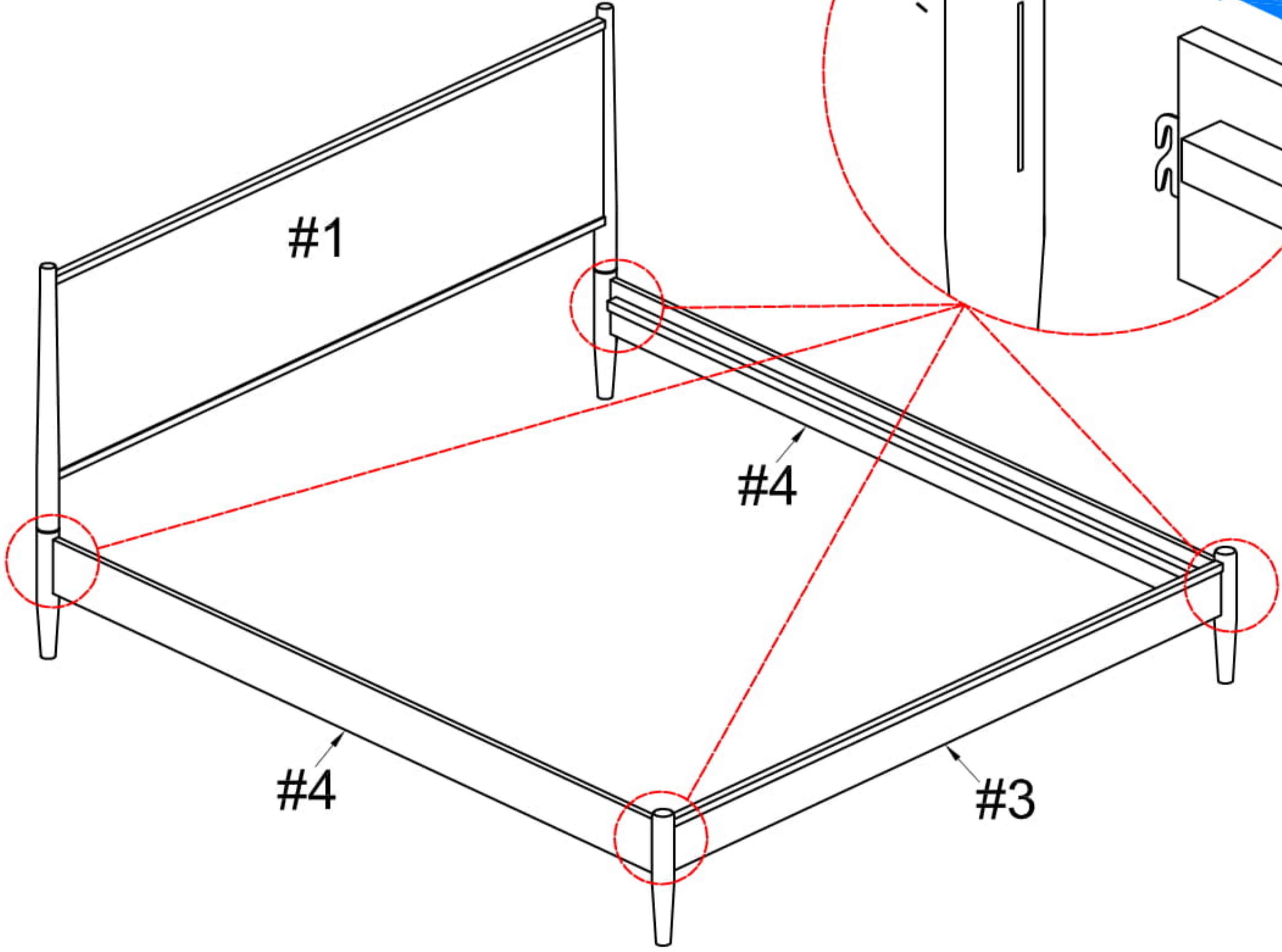

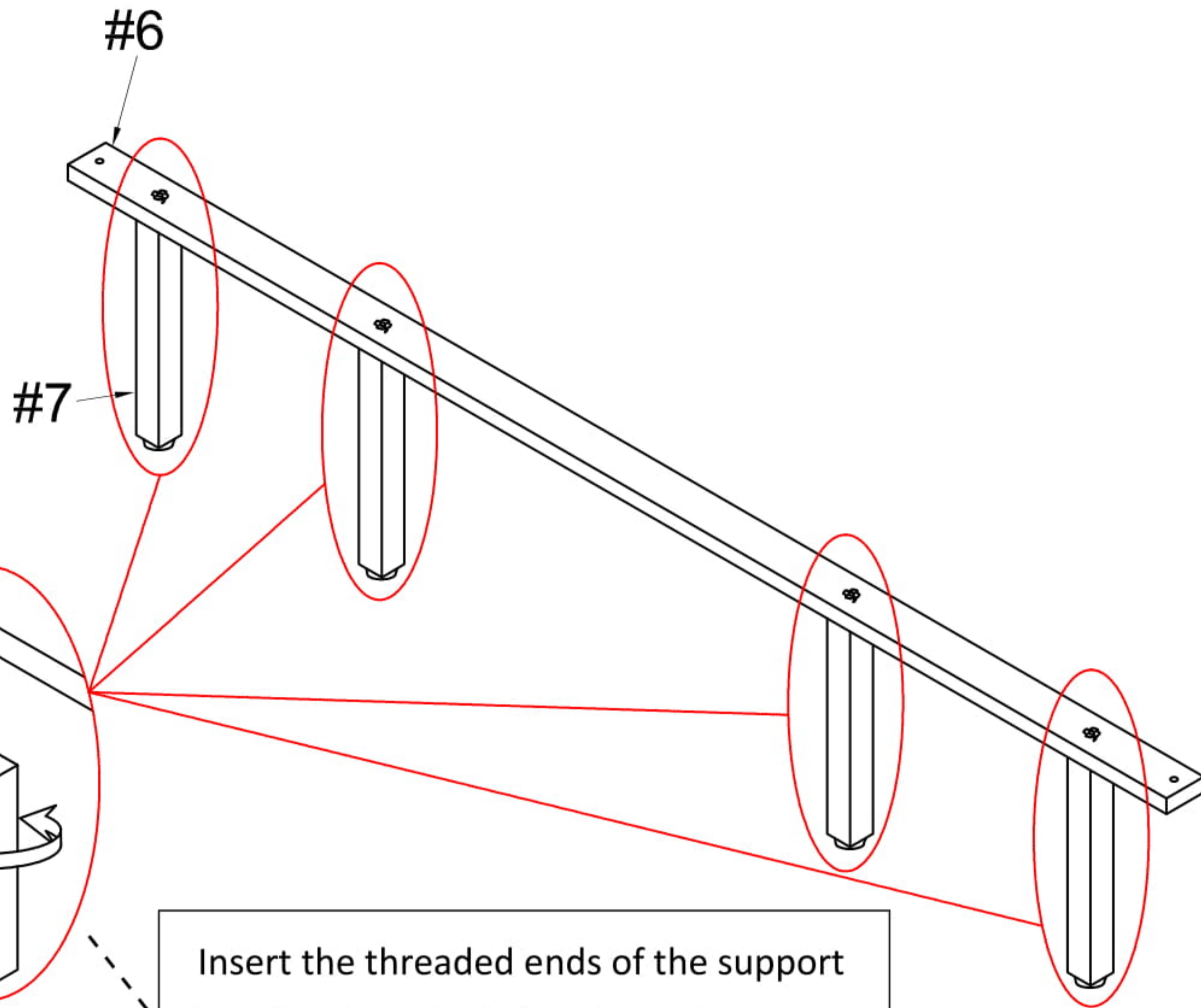

Insert the threaded ends of the support legs (#7) into the holes along the center rail (#6), turn right to tighten.

Adjust according to the ground level.



#E x 12pcs

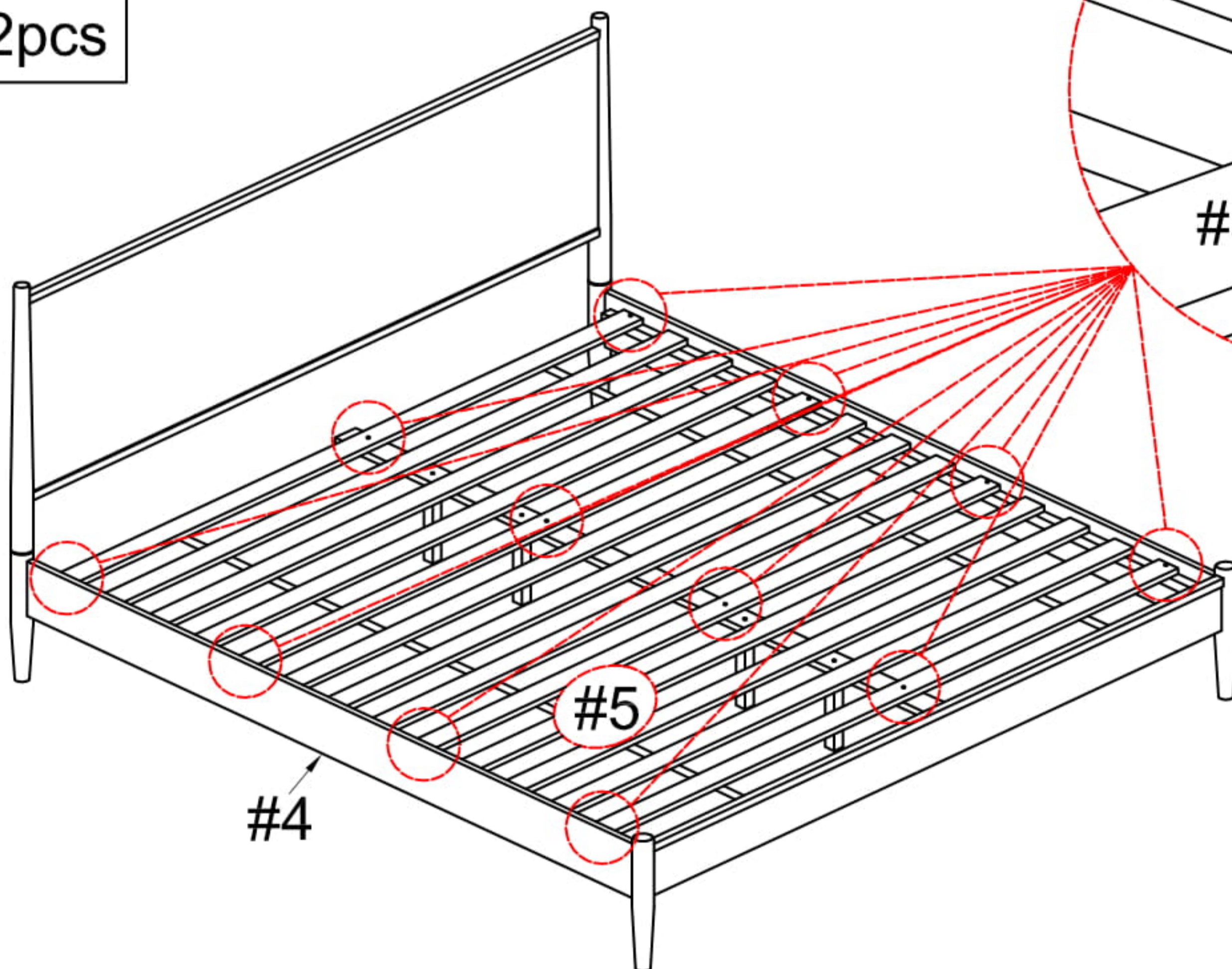

Place the bed slats (#5) onto the rails, then insert a screw (#E) into each hole. Secure using a screwdriver.

ASSEMBLY IS COMPLETED



Furniture of America®

Assembly Instructions

For more information contact our team: service.ec@foagroup.com

CM7386T

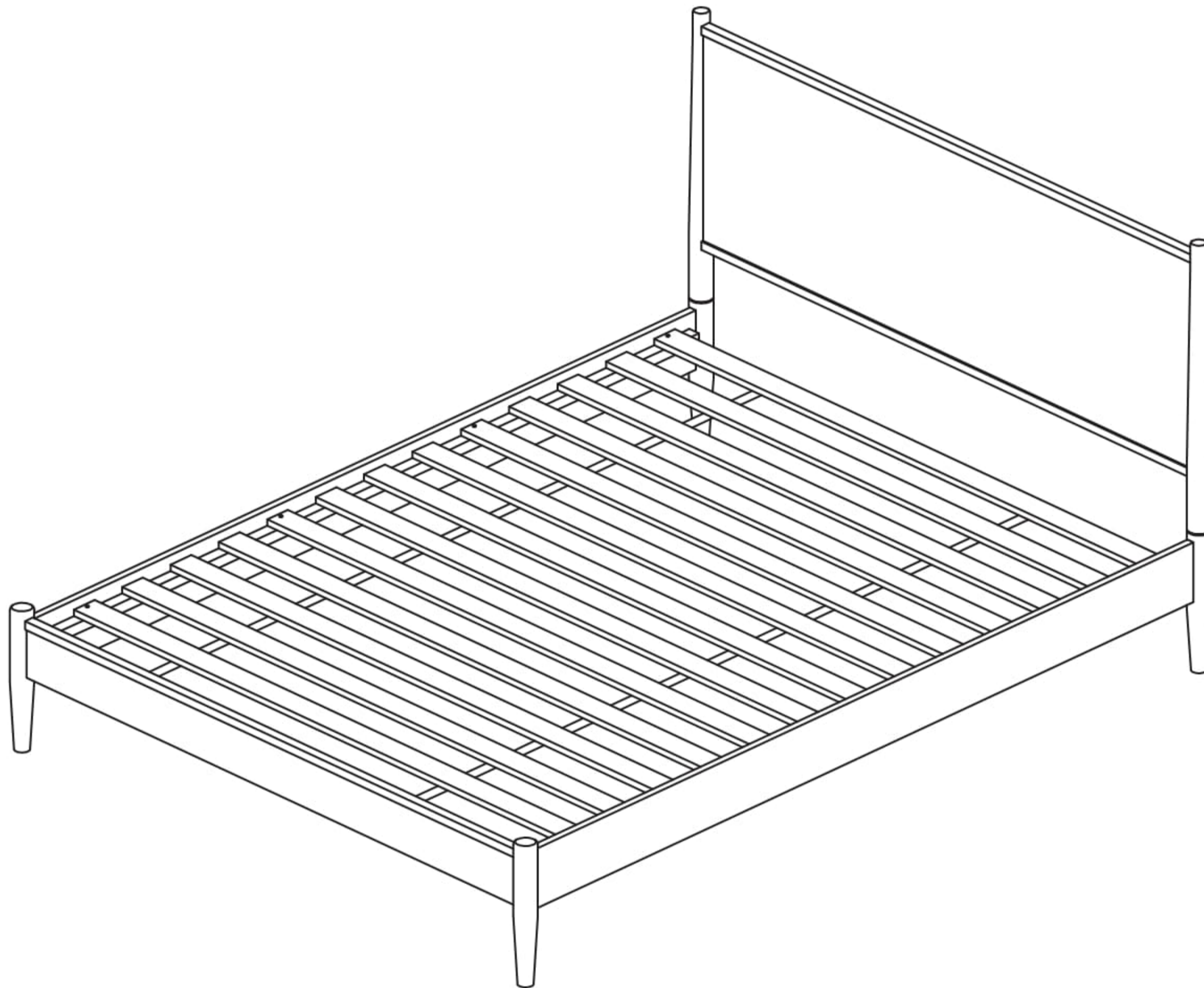

ASSEMBLY RATING

The Assembly Rating is a 5-point system that shows the degree of effort needed in assembling a specific product (with 1 being easy and 5 being difficult). For some products, two persons are recommended.

Tools Required For Assembly:

Allen Wrench

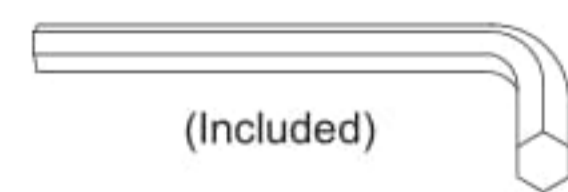

Phillips Screwdriver

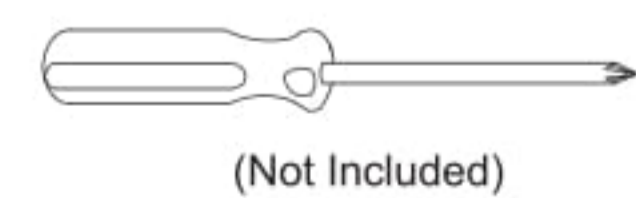

EASY

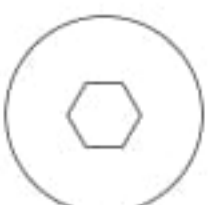
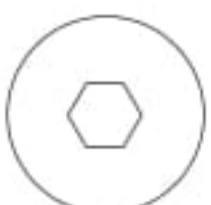

DIFFICULT



2 PERSONS RECOMMENDED

ASSEMBLY & CARE ADVICE

FOR YOUR FURNITURE TO LAST, CORRECT ASSEMBLY AND PROPER MAINTENANCE ARE NECESSARY. PLEASE FOLLOW THE INFORMATION PROVIDED BELOW TO FULLY ENJOY YOUR FURNITURE.

BASIC ASSEMBLY TECHNIQUES

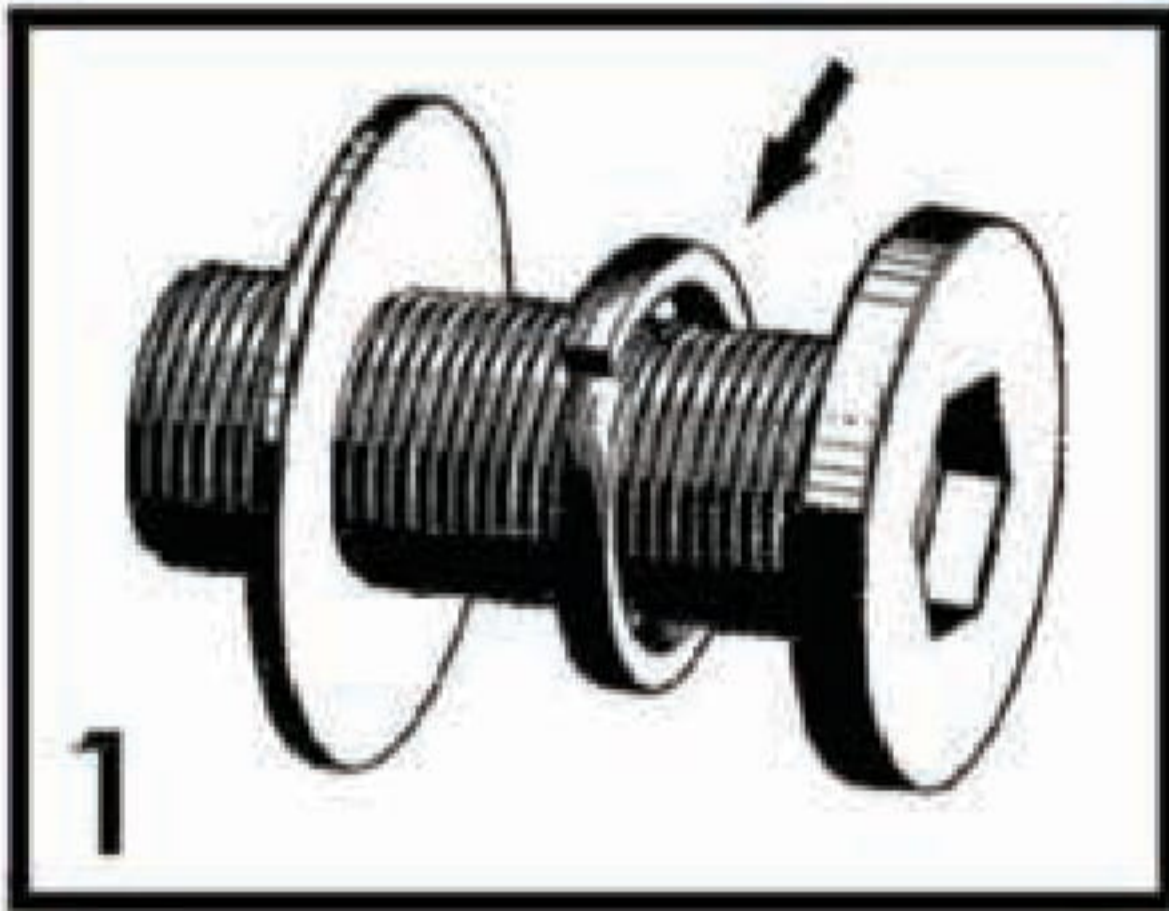

1
When lock or spring washer is used in an assembly, please make sure the lock or spring washer is placed between the larger flat washer and the head of the screw or bolt.

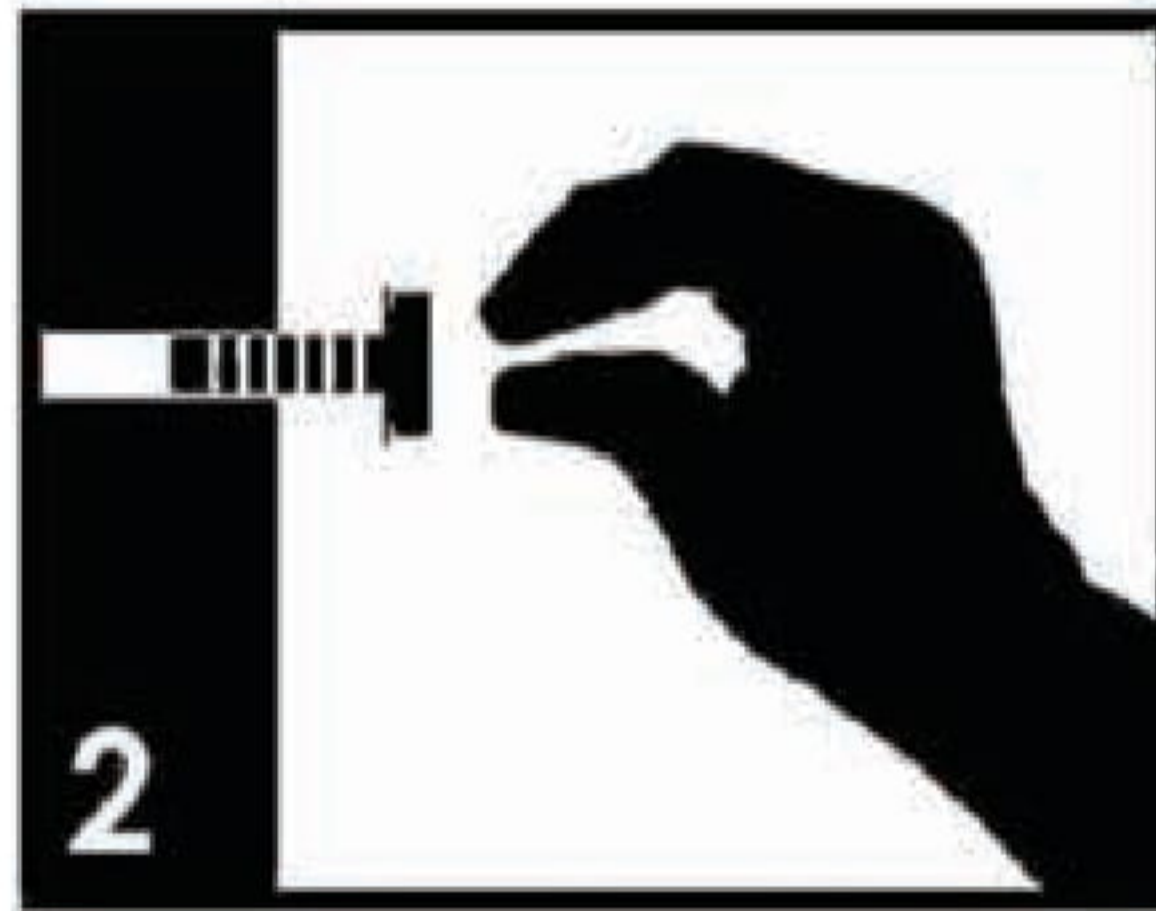

2
Position each part correctly and insert screws or bolts into their respective holes by hand tighten or using the proper hand tool. Only tighten when step is completed or when instructed to do so.



3
Use cardboard or carpet area when assembling furniture to prevent scratches. Make sure the furniture rests on a flat and level surface with each leg evenly touching the floor.

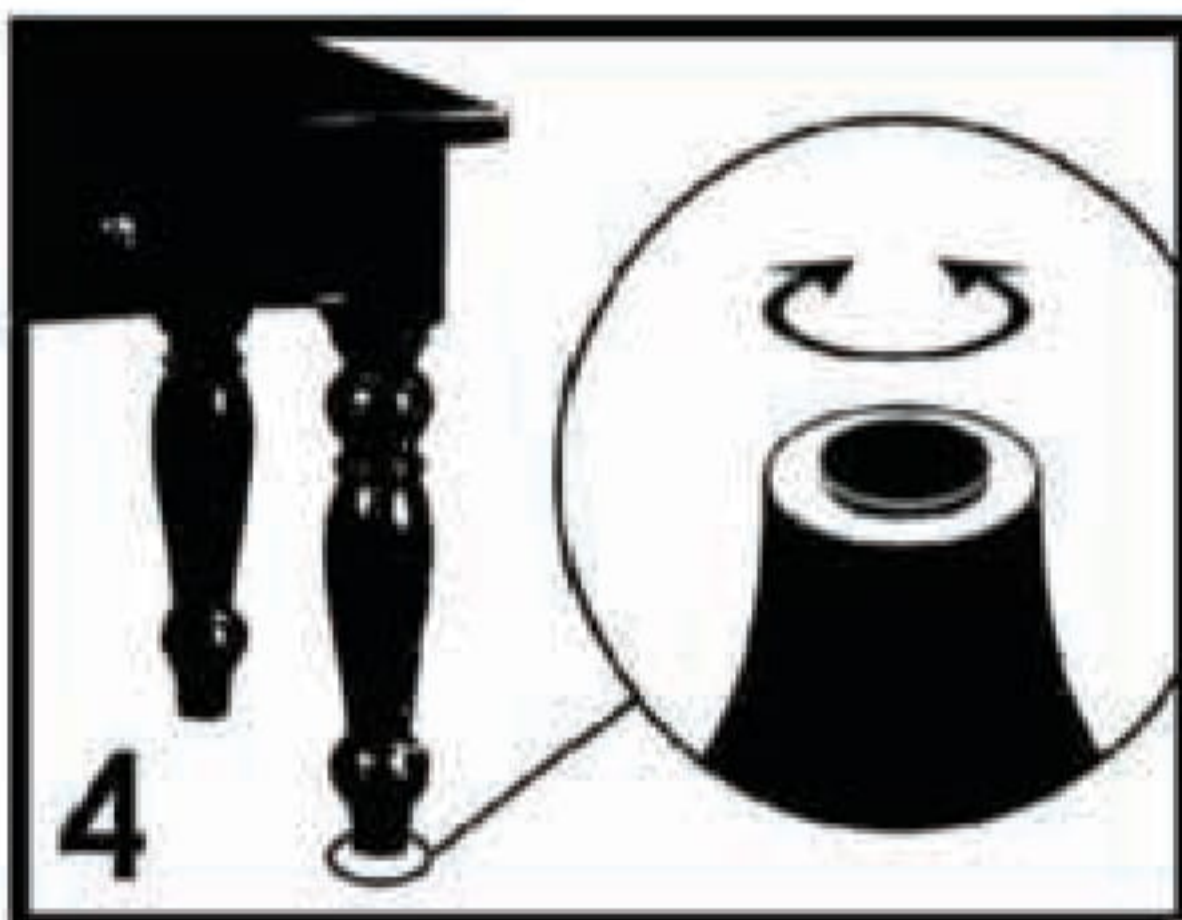

4
Some furniture comes with height adjustment knobs underneath each leg. To lower or to raise each leg, you need to turn clockwise or counterclockwise, respectively.

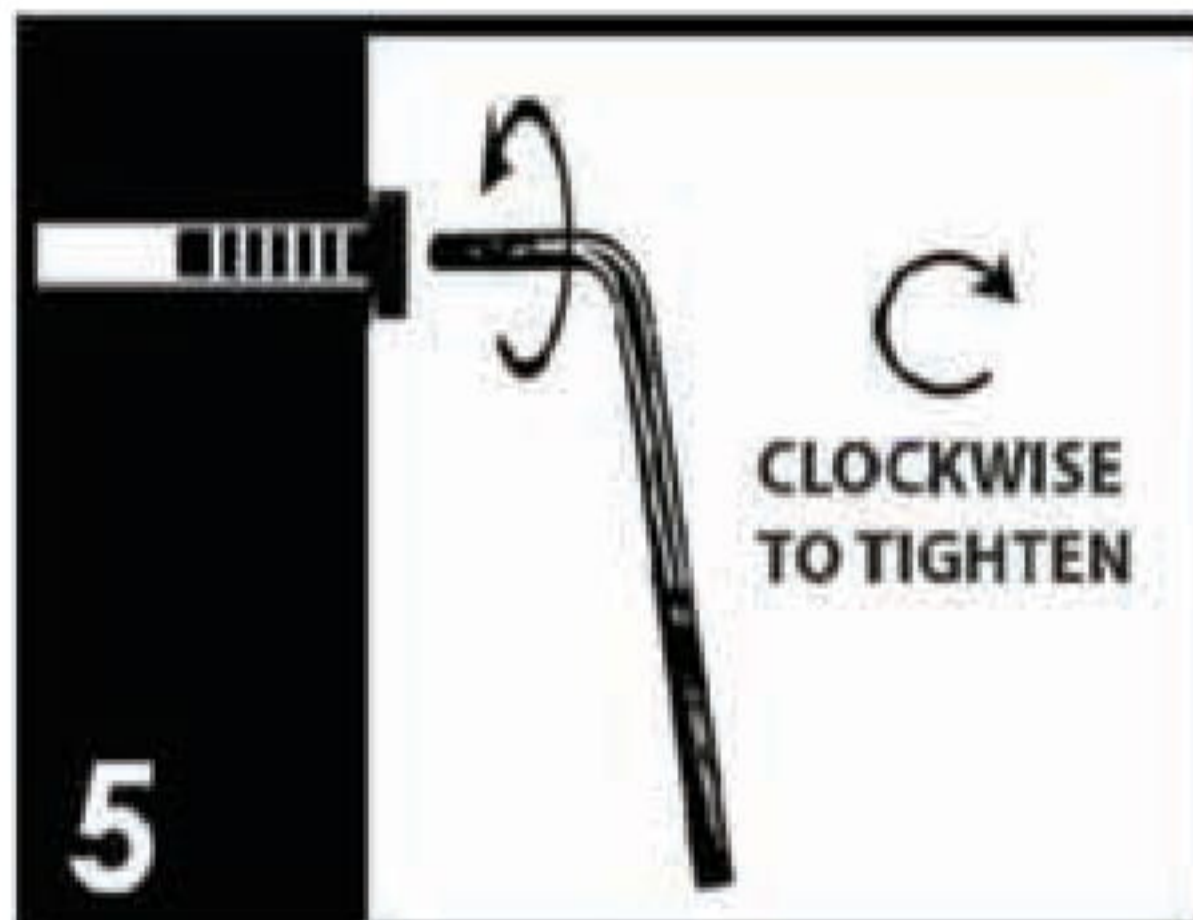

5
Make sure all parts are properly aligned, then use the appropriate hand tool to completely tighten the bolts or screws. Do not use power tools and do not overtighten.

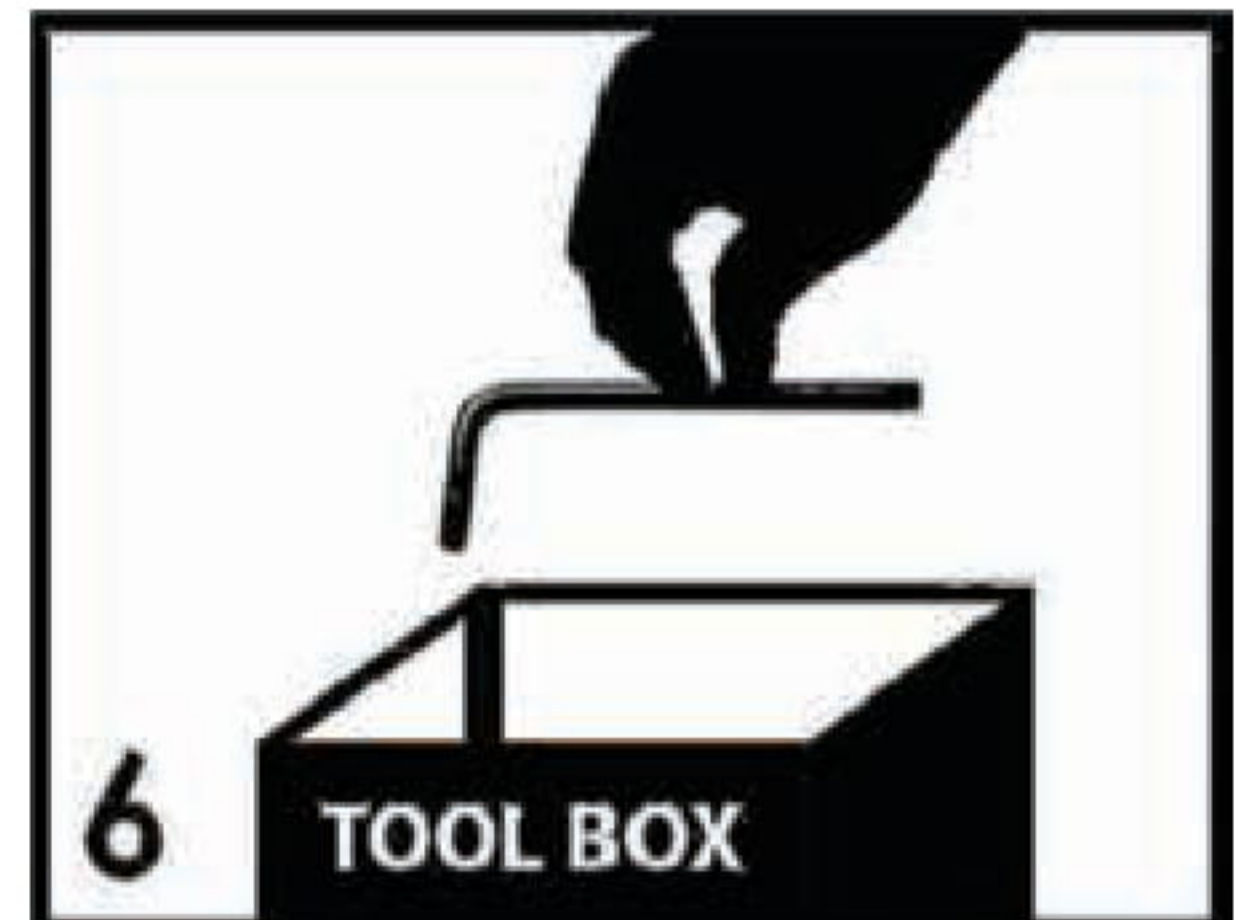

6
Save the instructions and store the Allen wrench or any supplied tool for later maintenance. After two weeks, check and tighten any loose hardware and repeat again every six months thereafter.

IT IS THE USER'S RESPONSIBILITY TO MAINTAIN THE FURNITURE. THE HARDWARE MAY LOOSEN OVER TIME AND MAY CAUSE THE FURNITURE TO BE WOBBLY AND UNABLE TO SUPPORT ITS INTENDED WEIGHT CAPACITY. THIS MAY LEAD TO COLLAPSE AND MAY CAUSE SERIOUS INJURY.



FAILURE TO FOLLOW THE GUIDELINES ABOVE MAY RESULT IN INJURY AND/OR PROPERTY DAMAGE.



Before you begin, please read Page 2 of "Assembly and Care Advice".

And remember, do not tighten until each step is completed or instructed.

Parts List

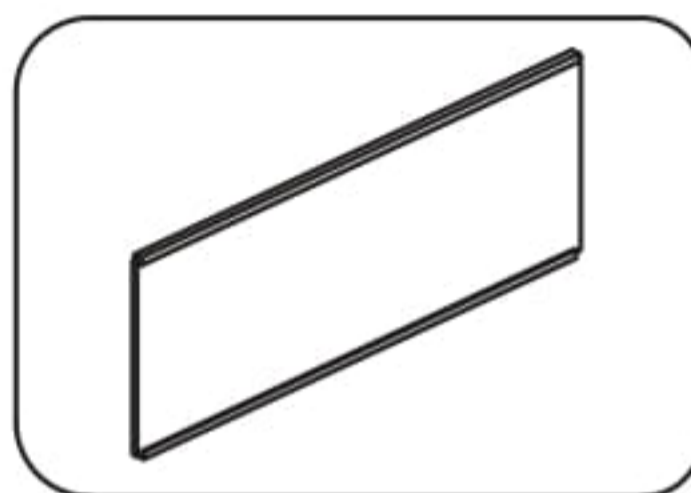

#1 x 1pc
Headboard

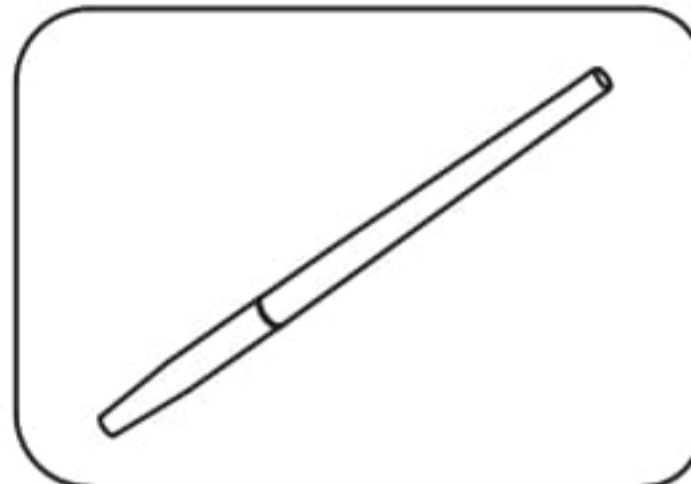

#2 x 2pcs
Headboard Leg (L&R)

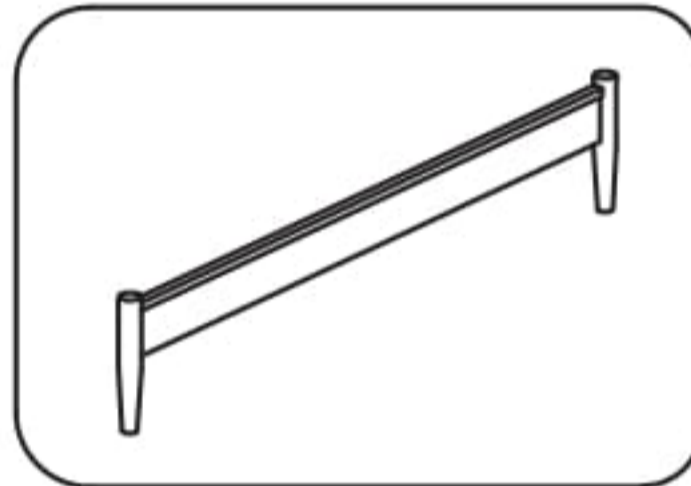

#3 x 1pc
Footboard

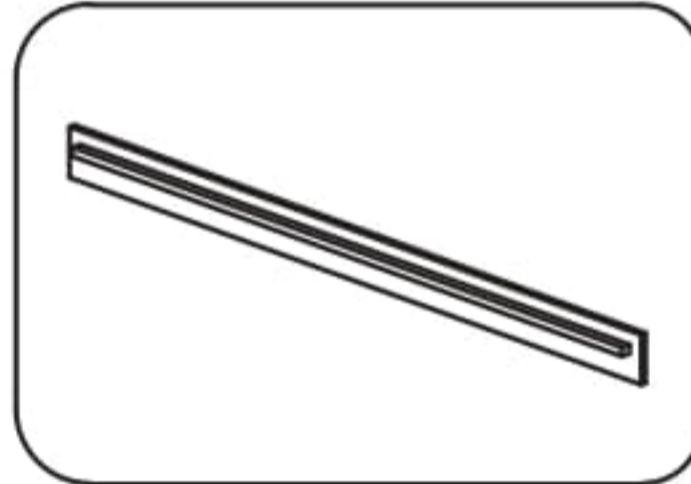

#4 x 2pcs
Rail

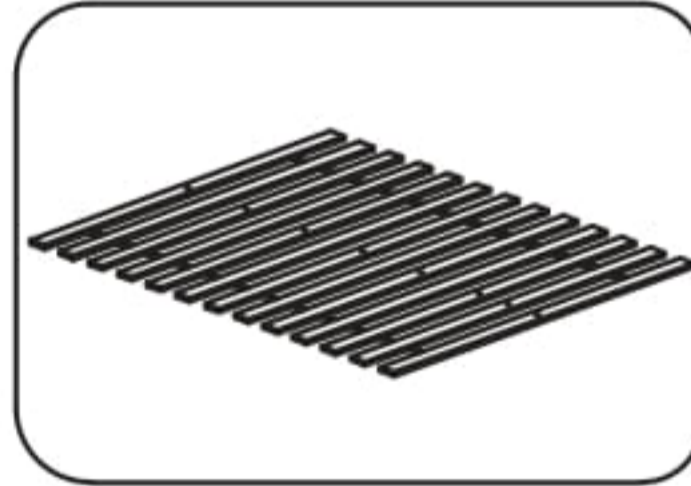

#5 x 1Set (13pcs)
Bed Slat

Hardware List

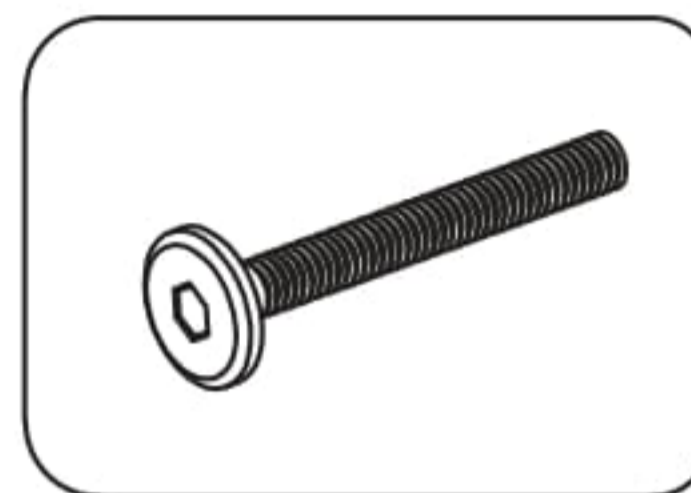

#A x 6pcs
Bolt $\text{Ø}1/4"$ x 1-3/8"

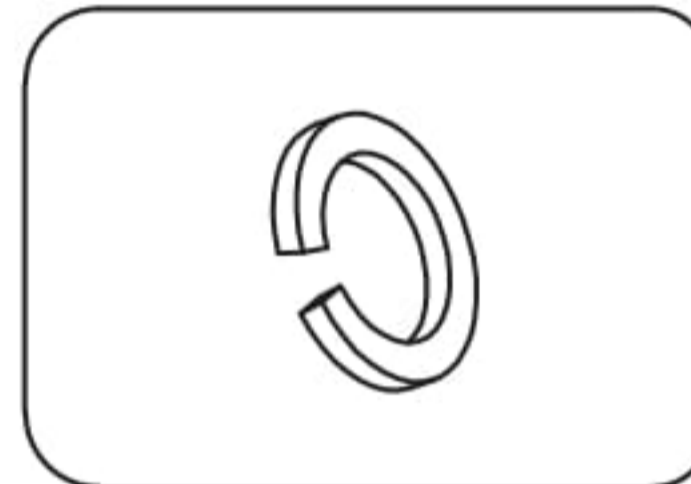

#B x 6pcs
Lock washer $\text{Ø}1/4"$

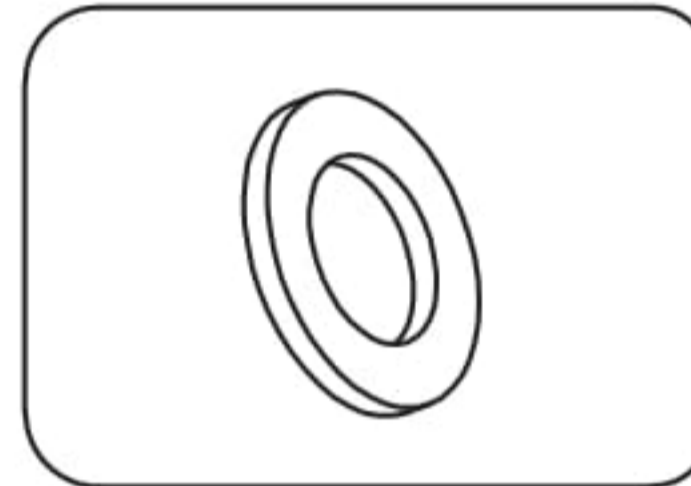

#C x 6pcs
Flat washer $\text{Ø}1/4"$ -3/4"

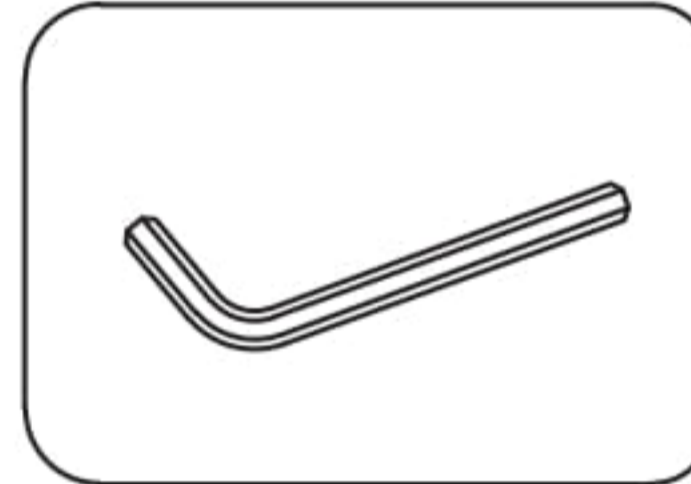

#D x 1pc
Allen wrench M4

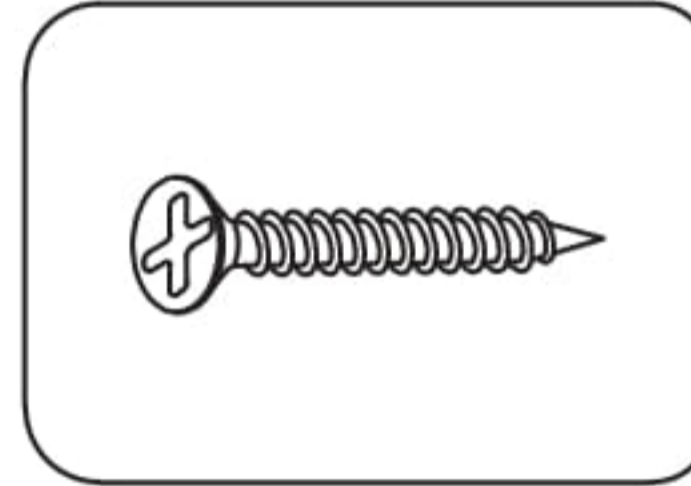

#E x 8pcs
Screw #5/32"x1-3/16"



Prepare 6 bolts assembly by inserting lock washer (#B), then flat washer (#C) onto bolts (#A).
Align headboard legs (#2R/L) to the holes of the headboard (#1). Secure with bolts (#A).

#A x 6pcs
#B x 6pcs
#C x 6pcs

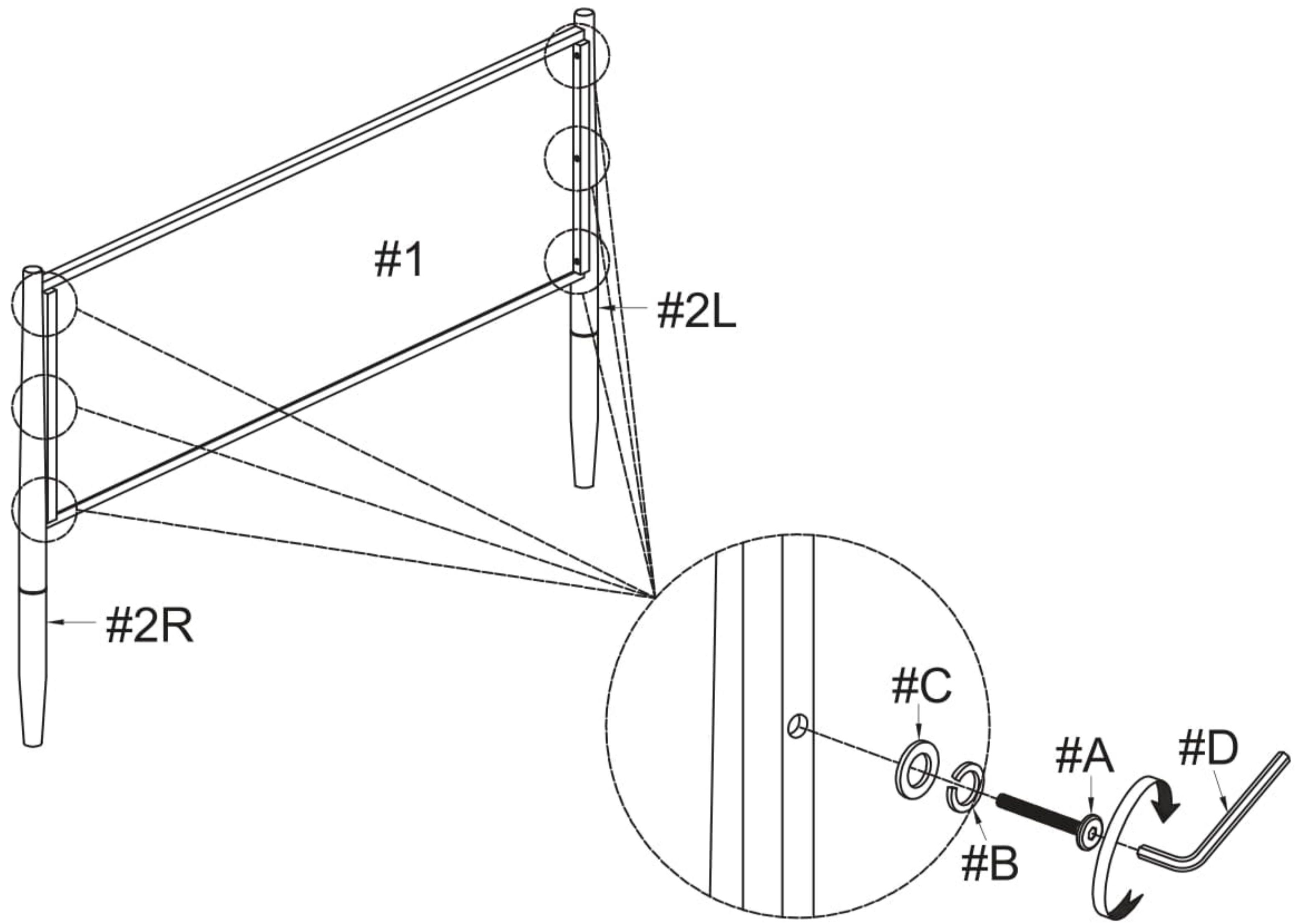

Hook the side rails (#4) to the latch of the headboard (#1) and footboard (#3). Make sure the side rails (#4) are on firmly.

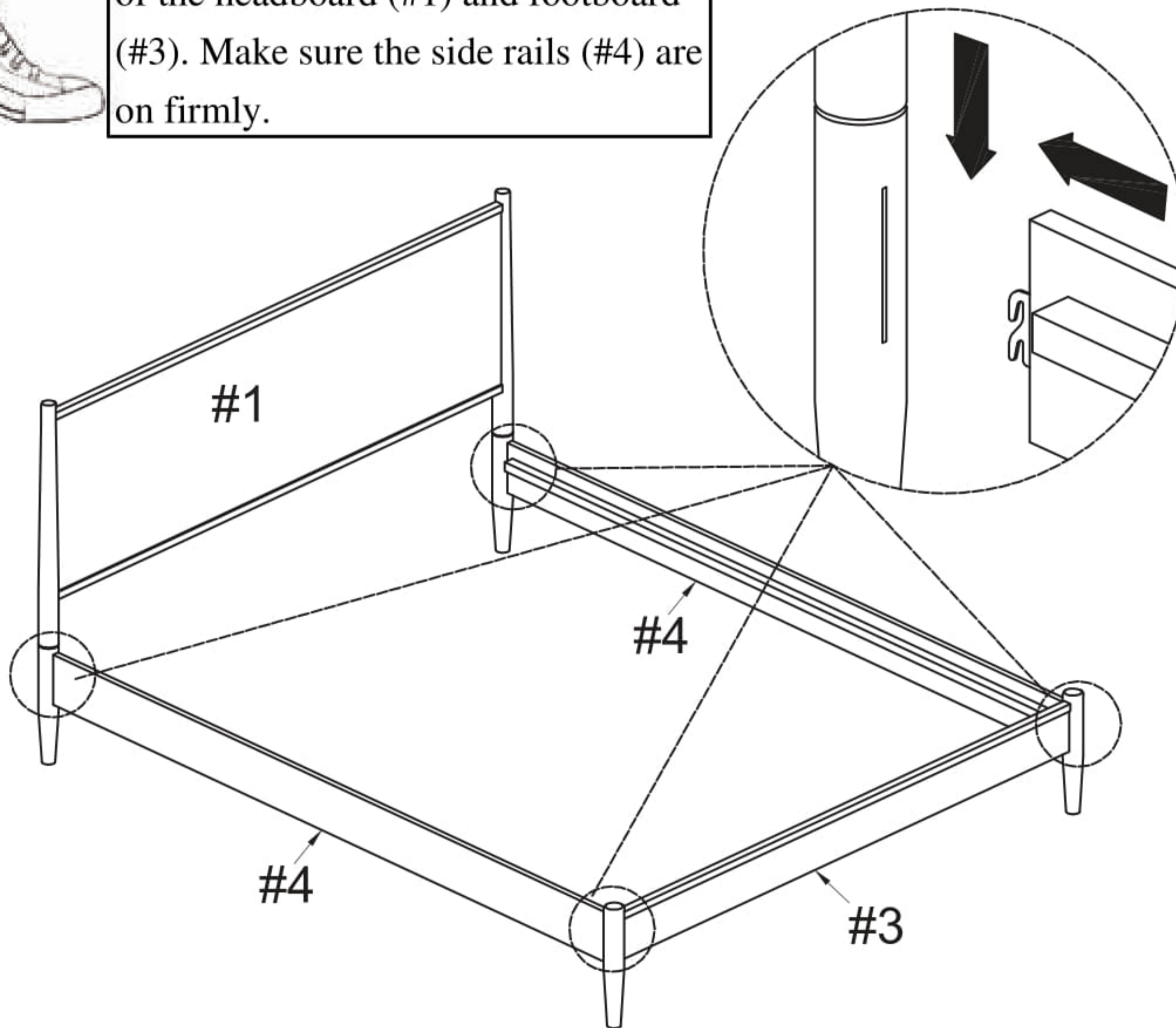

Align slats (#5) to the side rails (#4), then secure with screws (#E).



#E x 8pcs

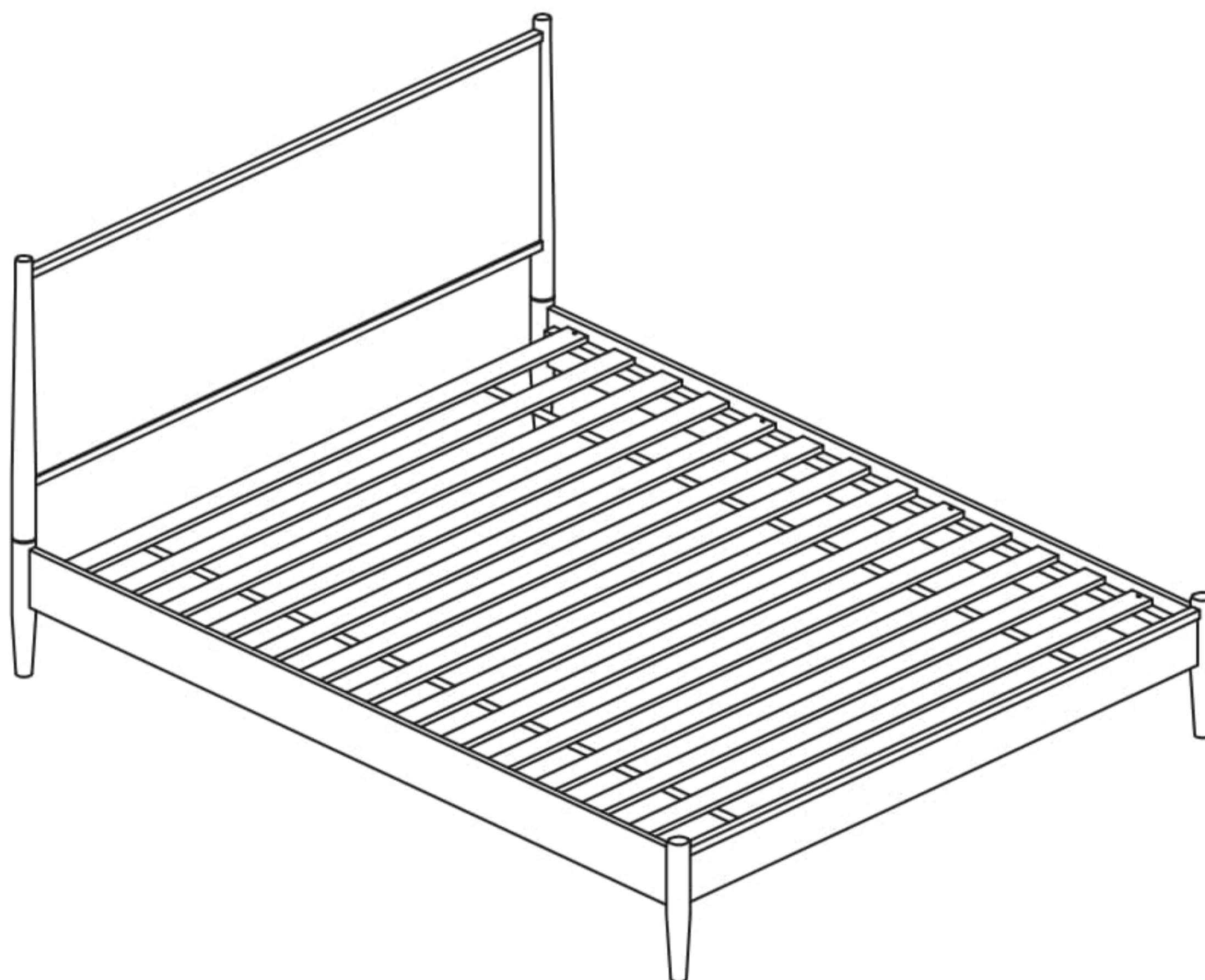
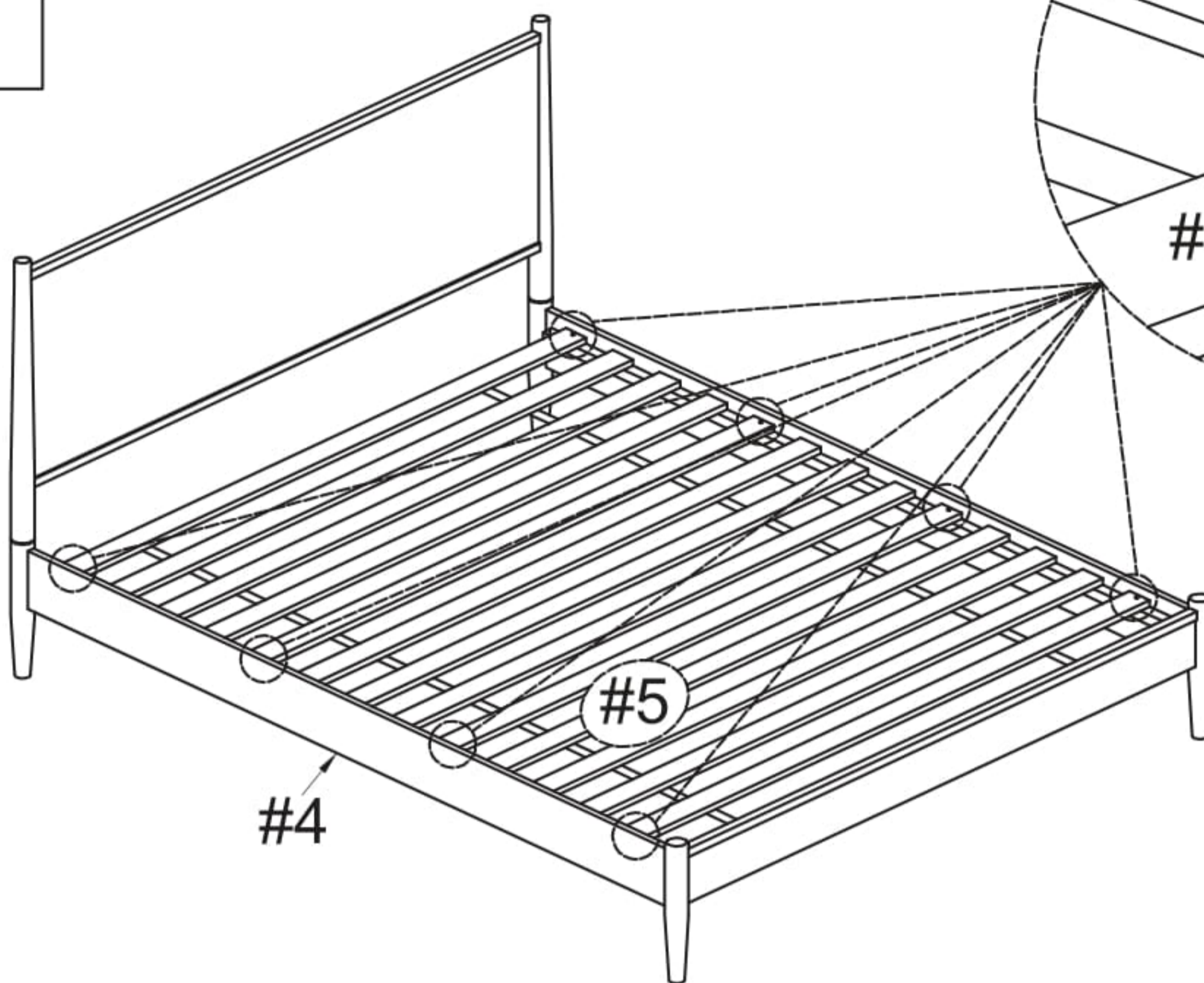

ASSEMBLY IS COMPLETED