

Assembly Instructions

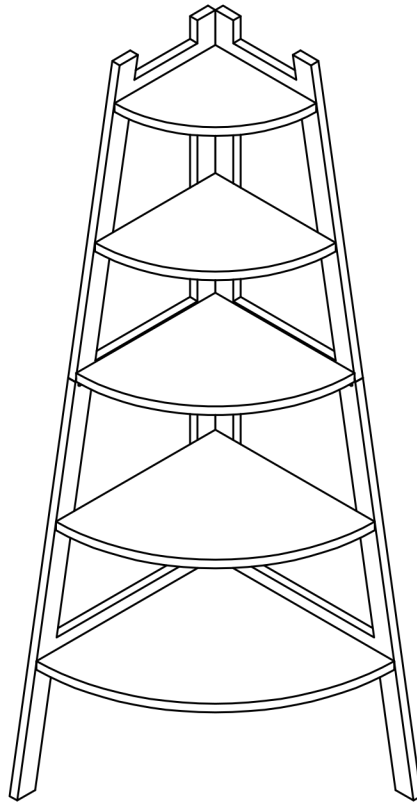

ASSEMBLY RATING

The Assembly Rating is a 5-point system that shows the degree of effort needed in assembling a specific product (with 1 being easy and 5 being difficult). For some products, two persons are recommended.

EASY  DIFFICULT

Tools Required For Assembly:

Allen Wrench

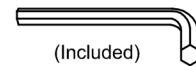

(Included)

Phillips Screwdriver



(Not Included)

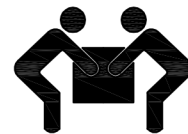

2 PERSONS RECOMMENDED

ASSEMBLY & CARE ADVICE

FOR YOUR FURNITURE TO LAST, CORRECT ASSEMBLY AND PROPER MAINTENANCE ARE NECESSARY. PLEASE FOLLOW THE INFORMATION PROVIDED BELOW TO FULLY ENJOY YOUR FURNITURE.

BASIC ASSEMBLY TECHNIQUES

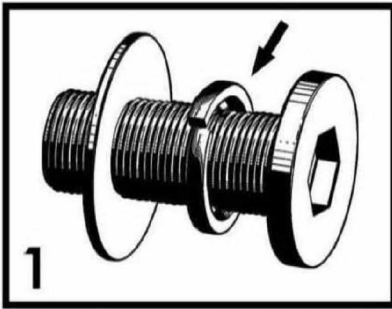

1
When lock or spring washer is used in an assembly, please make sure the lock or spring washer is placed between the larger flat washer and the head of the screw or bolt.

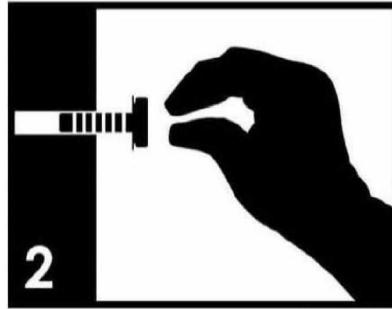

2
Position each part correctly and insert screws or bolts into their respective holes by hand tighten or using the proper hand tool. Only tighten when step is completed or when instructed to do so.

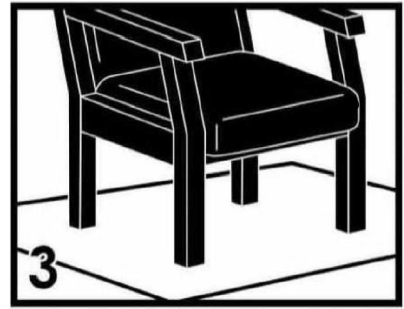

3
Use cardboard or carpet area when assembling furniture to prevent scratches. Make sure the furniture rests on a flat and level surface with each leg evenly touching the floor.

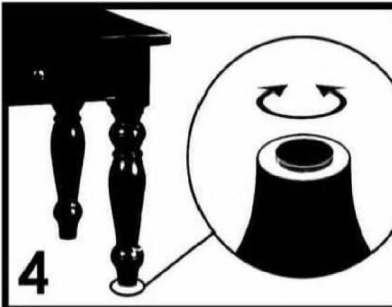

4
Some furniture comes with height adjustment knobs underneath each leg. To lower or to raise each leg, you need to turn clockwise or counterclockwise, respectively.

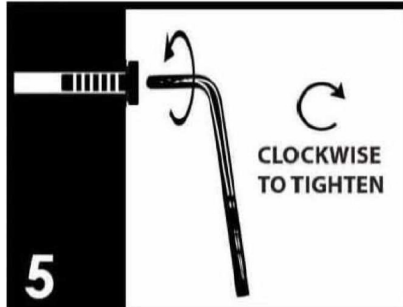

5
Make sure all parts are properly aligned, then use the appropriate hand tool to completely tighten the bolts or screws. Do not use power tools and do not overtighten.



6
Save the instructions and store the Allen wrench or any supplied tool for later maintenance. After two weeks, check and tighten any loose hardware and repeat again every six months thereafter.

IT IS THE USER'S RESPONSIBILITY TO MAINTAIN THE FURNITURE. THE HARDWARE MAY LOOSEN OVER TIME AND MAY CAUSE THE FURNITURE TO BE WOBBLY AND UNABLE TO SUPPORT ITS INTENDED WEIGHT CAPACITY. THIS MAY LEAD TO COLLAPSE AND MAY CAUSE SERIOUS INJURY.





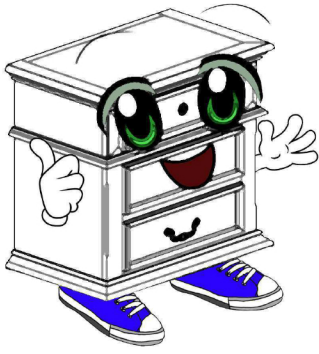





FAILURE TO FOLLOW THE GUIDELINES ABOVE MAY RESULT IN INJURY AND/OR PROPERTY DAMAGE.

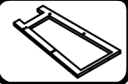
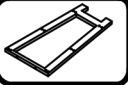







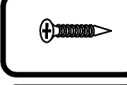

Before you begin, please read Page 2 of "Assembly and Care Advice".

And remember, do not tighten until each step is completed or instructed.

Parts List

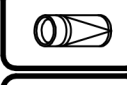
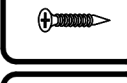
-  #1 x 1pc
TOP-LEFT FRAME
-  #2 x 1pc
TOP-RIGHT FRAME
-  #3 x 1pc
BOTTOM-LEFT FRAME
-  #4 x 1pc
BOTTOM-RIGHT FRAME
-  #5 x 1pc
TOP SHELF SMALLEST SIZE
-  #6 x 1pc
2nd SMALLEST SHELF
-  #7 x 1pc
MIDDLE SHELF
-  #8 x 1pc
2nd LARGEST SHELF
-  #9 x 1pc
BOTTOM SHELF LARGEST SIZE

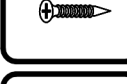
Hardware List

-  #A x 20pcs
PHILIP HEAD SCREW 3/16X45MM
-  #B x 4pcs
FLAT HEAD WOOD SCREW 4X35MM
-  #C x 20pcs
"T" NUT 3/16X8MM
-  #D x 19pcs
WOOD DOWEL 6X30MM
-  #E x 20pcs
WOOD PLUG 13X9MM
-  #F x 1pc
GLUE
-  #G 2pcs
3X15MM
-  #H 4pcs
4X10MM
-  #I 2pcs
3.5X20MM
-  #J 2pcs
-  #K 2pcs
20X150MM

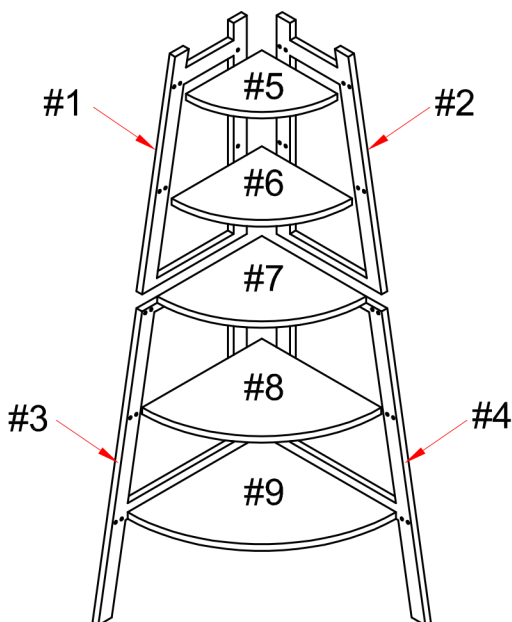



#1

#A x 6 pcs
#C x 6 pcs
#D x 6 pcs

Note: shelf size coordinates with the size of the frame.

1. Apply glue onto the wood dowels (#D) and insert into the top right frame (#2). Apply glue onto the other ends and insert shelves (#5,6,7).

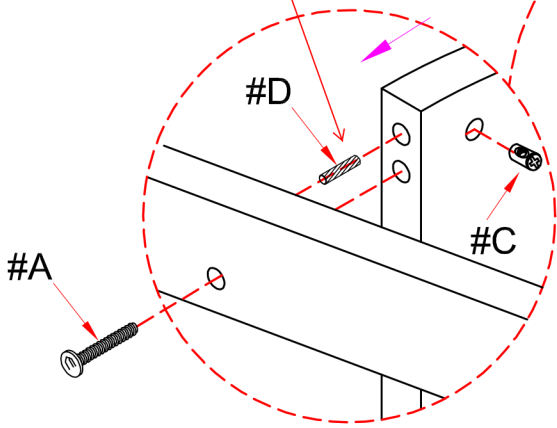
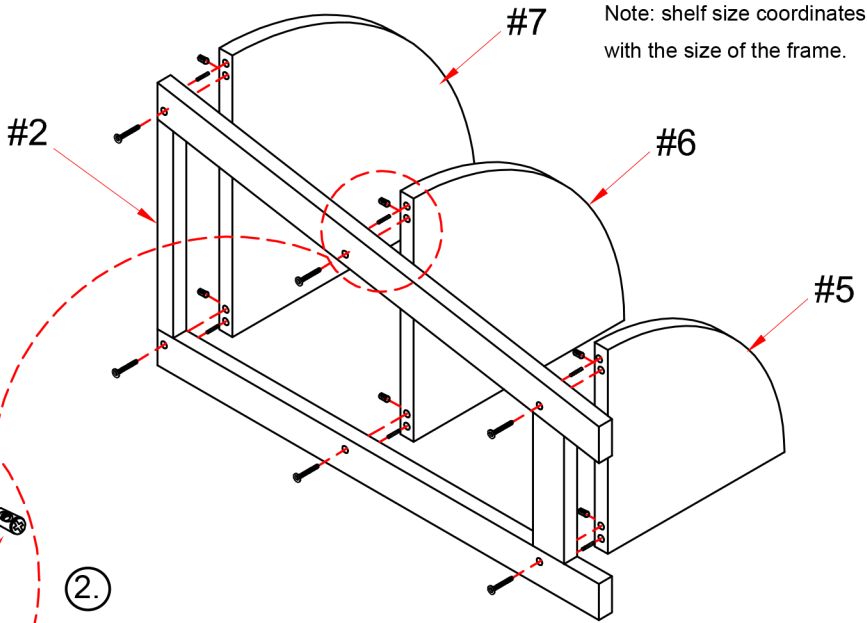

2.

- I. Insert the barrel nut (#C), Slide the Phillip head screw (#A) through the hole on the side of the post piece until it bumps against the nut.
- II. Use your screwdriver to rotate the barrel nut (#C) until the hole is lined up with the end of the screw. Hold the barrel nut in position with your screwdriver. Simultaneously use the wrench to turn the screw. Continue tightening until the bolt is fully seated.



#2

#A x 6 pcs
#C x 6 pcs
#D x 3 pcs

1. Apply glue onto the wood dowels (#D) and insert into the top left frame (#1). Apply glue onto the other ends and insert shelves (#5,6,7).

- I. Insert the barrel nut (#C), Slide the Phillip head screw (#A) through the hole on the side of the post piece until it bumps against the nut.
- II. Use your screwdriver to rotate the barrel nut (#C) until the hole is lined up with the end of the screw. Hold the barrel nut in position with your screwdriver. Simultaneously use the wrench to turn the screw. Continue tightening until the bolt is fully seated.

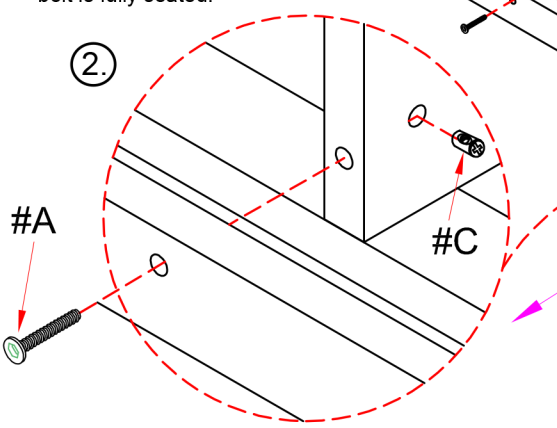
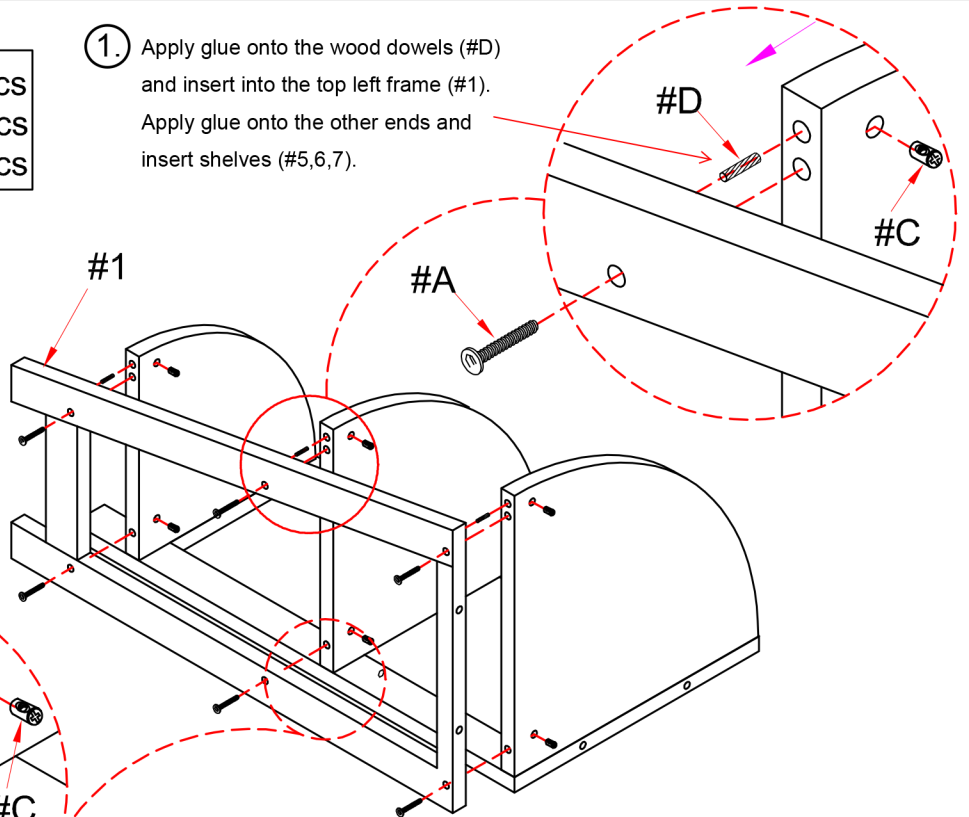

2.

Do not tighten screws until completely assembled.



#3

- #A x 4 pcs
- #C x 4 pcs
- #D x 4 pcs

1. Apply glue onto the wood dowels (#D) and insert into the bottom right frame (#4). Apply glue onto the other ends and insert shelves (#8,9).

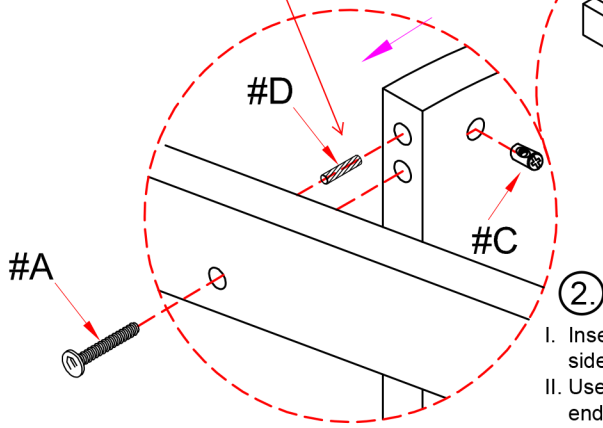
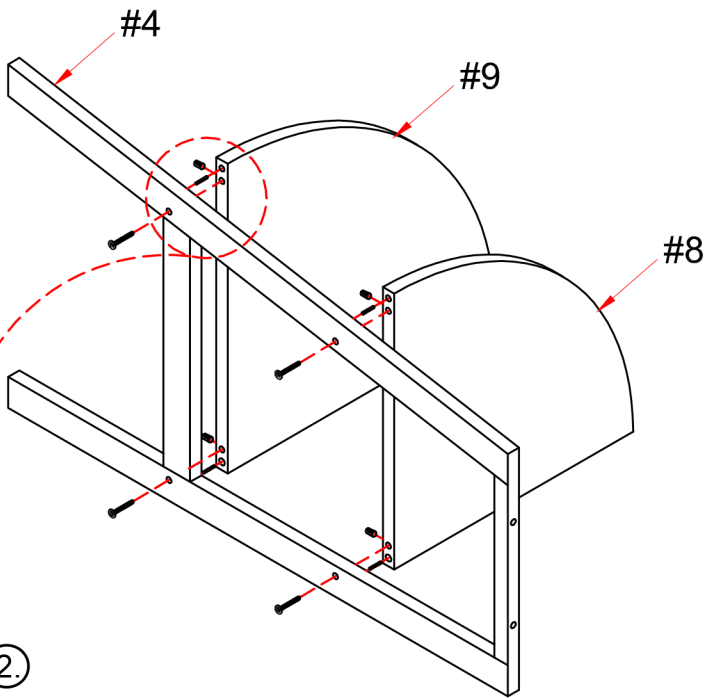

- I. Insert the barrel nut (#C), Slide the Phillip head screw (#A) through the hole on the side of the post piece until it bumps against the nut.
- II. Use your screwdriver to rotate the barrel nut (#C) until the hole is lined up with the end of the screw. Hold the barrel nut in position with your screwdriver. Simultaneously use the wrench to turn the screw. Continue tightening until the bolt is fully seated.



#4

- #A x 4 pcs
- #C x 4 pcs
- #D x 4 pcs

1. Apply glue onto the wood dowels (#D) and insert into the bottom left frame (#3). Apply glue onto the other ends and insert shelves (#8,9).

2.

- I. Insert the barrel nut (#C), Slide the Phillip head screw (#A) through the hole on the side of the post piece until it bumps against the nut.
- II. Use your screwdriver to rotate the barrel nut (#C) until the hole is lined up with the end of the screw. Hold the barrel nut in position with your screwdriver. Simultaneously use the wrench to turn the screw. Continue tightening until the bolt is fully seated.

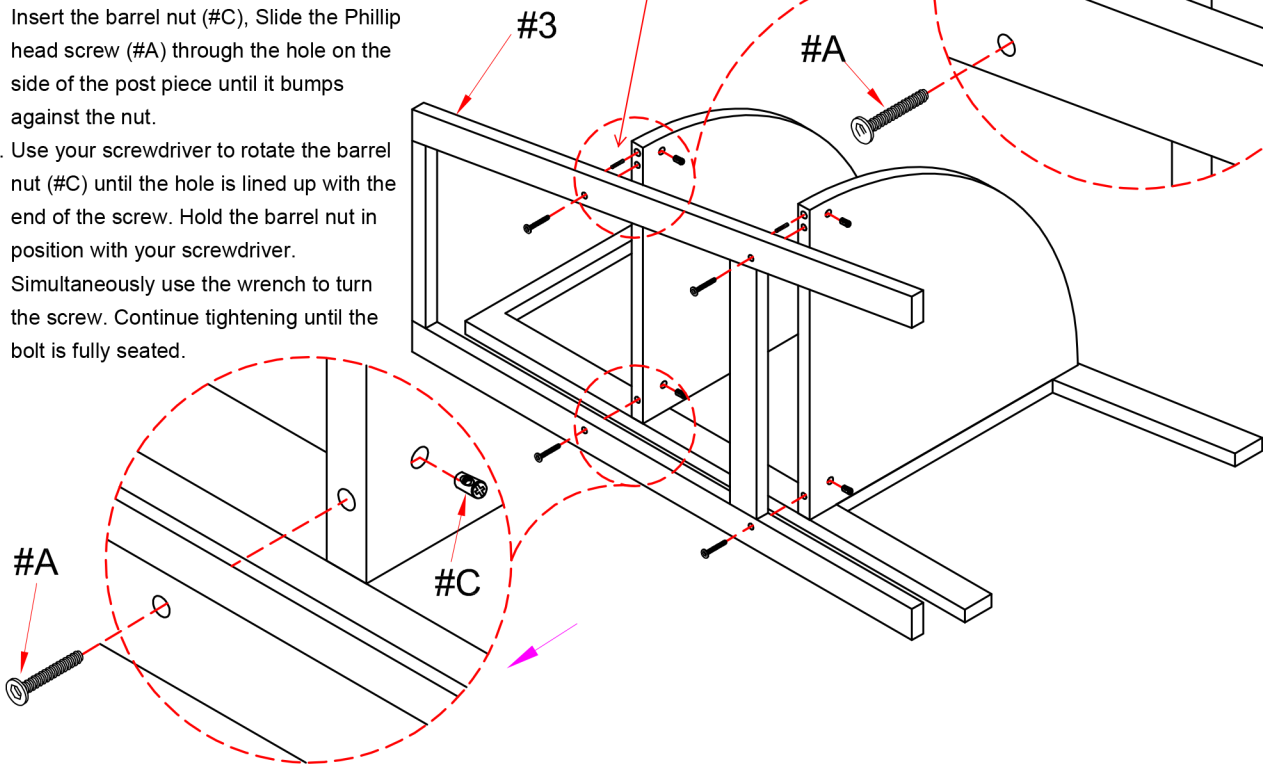
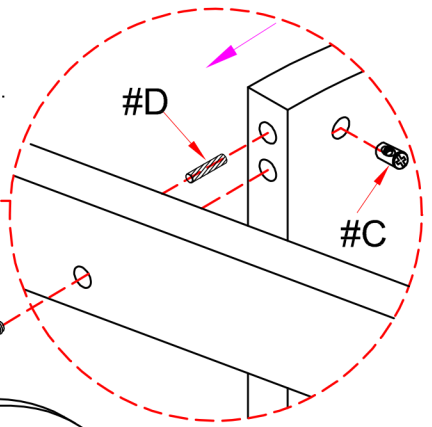

Do not tighten screws until completely assembled.



- #B x 4 pcs
- #D x 4 pcs
- #E x 20 pcs
- #G x 2 pcs
- #H x 4 pcs
- #I x 2 pcs
- #J x 2 pcs
- #K x 2 pcs

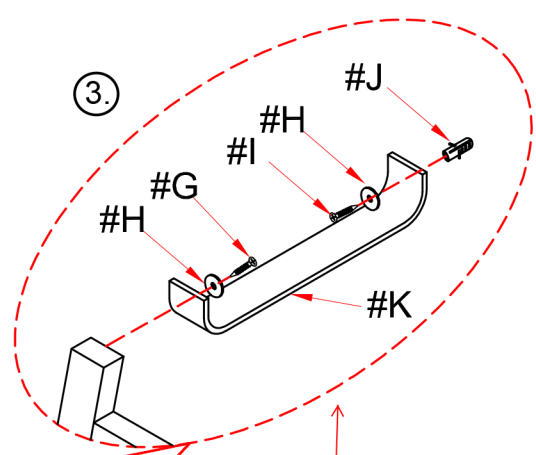

Insert a total of 20 wood plugs to fill the bolt holes.

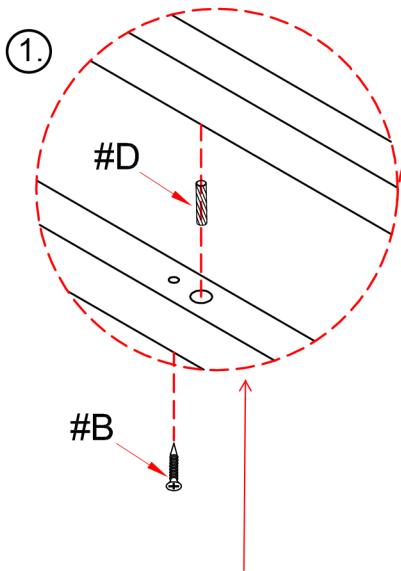
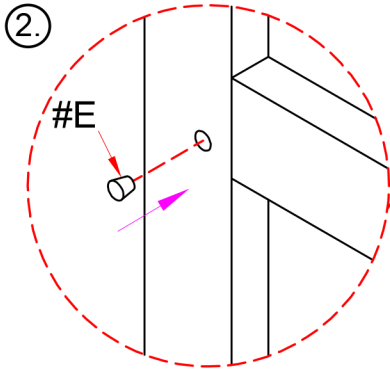

- I. Determine exactly where you want to drill a hole and mark the spot(s). Be sure that you hold the drill perpendicular to the wall. You should drill a hole that is approximately the same size as the screw.
- II. Insert a flat washer (#H) into screw (#I). Insert screw assembly into one end of (#K) and screw into the plug on the wall.
- III. Insert a flat washer (#H) into screw (#G). Insert screw assembly into the other end of (#K) and screw into the corners of the top frame. Repeat process for the other side.

- I. Insert 4 wood dowels (#D) with glue into the large pre-drilled holes on top of the bottom frames. Then, apply the top frames onto the other end of the wood dowels.
- II. Insert 4 screws (#B) into the bottom frames. Insert from below and secure using a Phillips screwdriver.