

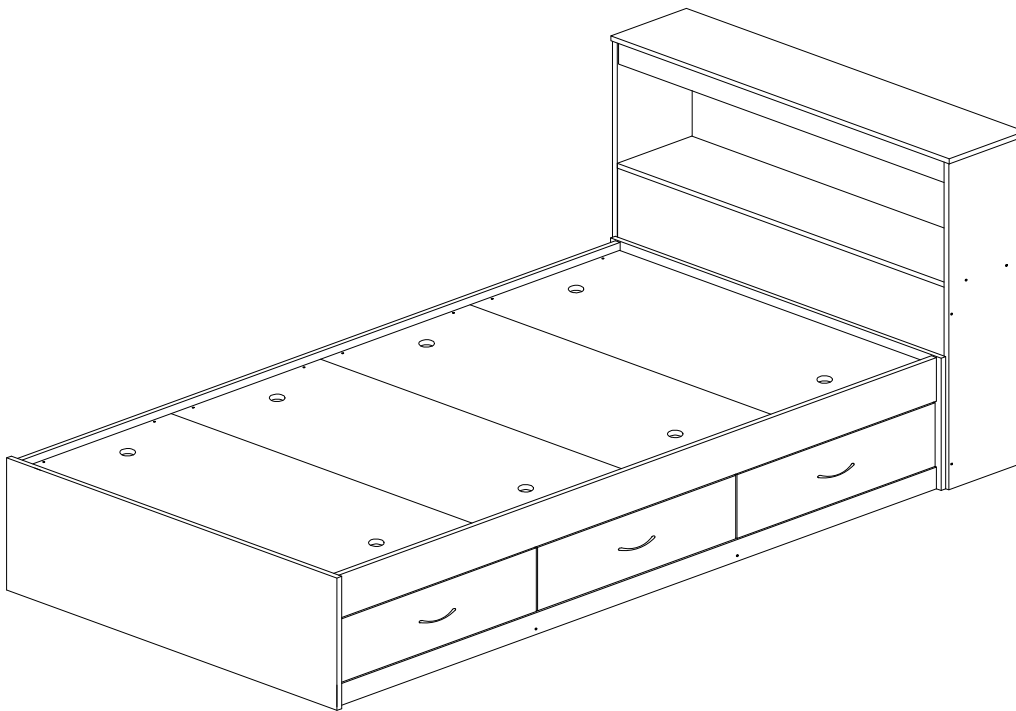

Hodedah
www.hodedah.com
[support @hodedah.com](mailto:support@hodedah.com)

ASSEMBLY INSTRUCTION HIBT 60-MOPV (SINGLE BED)

- ~ Before assembly, please read the instructions ~
- ~ Keep these instructions for future reference ~
- ~ Follow these steps to assemble the Bed ~



THIS INSTRUCTION BOOKLET CONTAINS IMPORTANT INFORMATION ABOUT ASSEMBLY AND SAFETY. PLEASE READ AND KEEP FOR FUTURE REFERENCE.



Parts

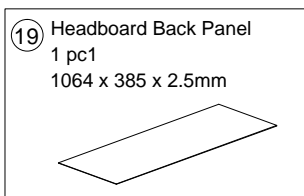
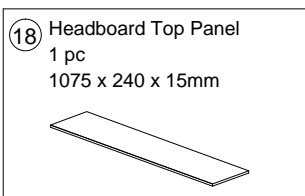
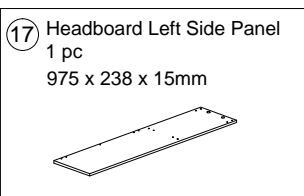
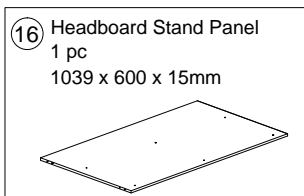
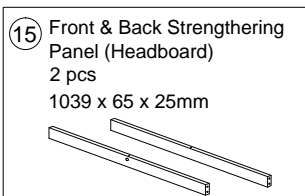
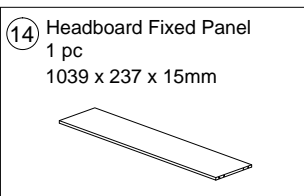
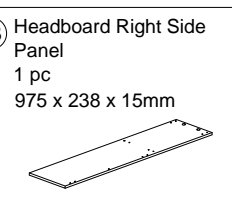
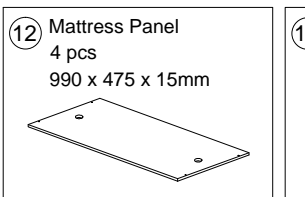
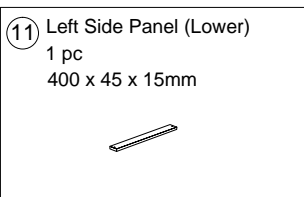
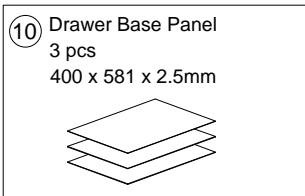
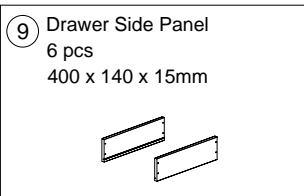
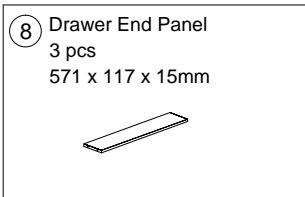
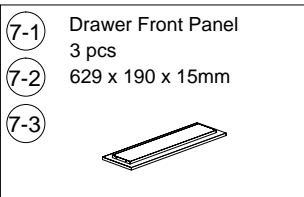
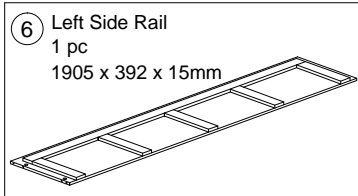
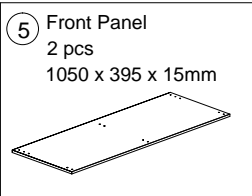
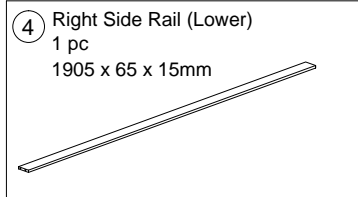
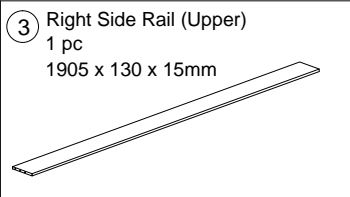
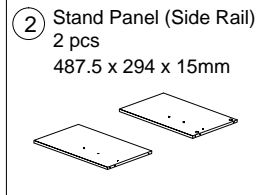
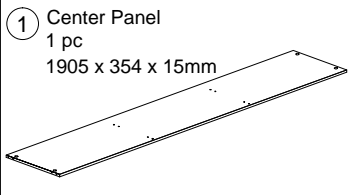

The parts of the product are packed in one box.
 There are inner box(es) or package(s) that included components and accessories required to complete the assembly



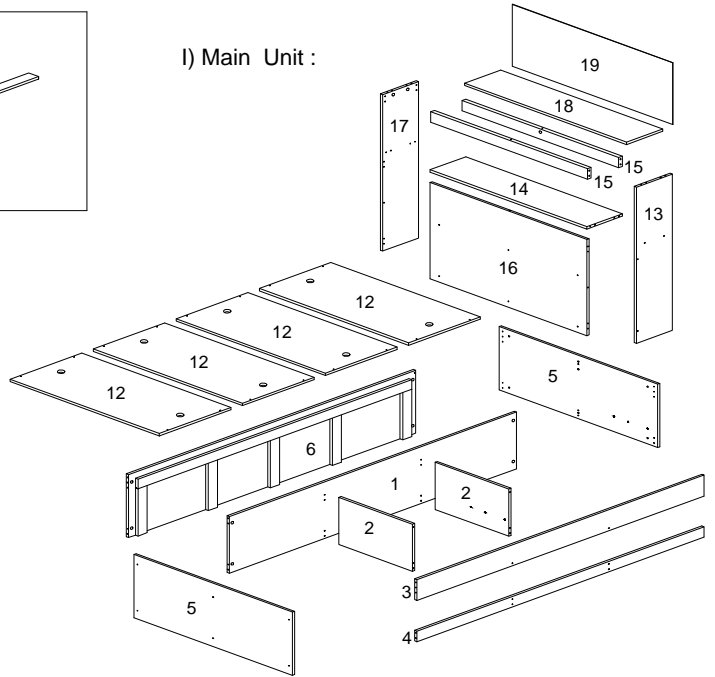



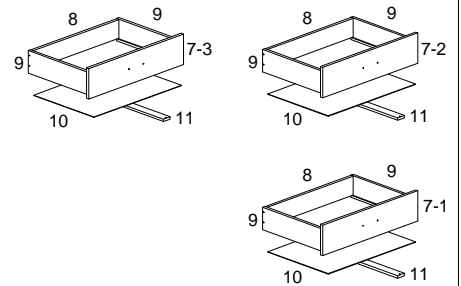





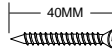
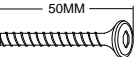

I) Main Unit :



II) Drawer :

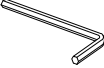

Hardware And Accessories

<p>A Plastic Dowel M8 x 25mm 46 pcs</p> 	<p>B CB Screw M3.5 x 12mm 36 pcs</p> 	<p>C CB Screw M4 x 25mm 6 pcs</p> 	<p>D CB Screw M4 x 30mm 6 pcs</p> 	<p>E CB Screw M4 x 35mm 46 pcs</p> 	<p>F CSK Cap Screw M6 x 40mm 14 pcs</p> 
<p>G JCBC Bolt M6 x 50mm 12 pcs</p> 	<p>H Barrel Nut 12 pcs</p> 	<p>I Nail 58 pcs</p> 	<p>J1 Minifix 5654 - Housing 9 pcs</p> 	<p>J2 Minifix 5654 - Screw 9 pcs</p> 	<p>K Pvc Cap 18 pcs</p> 
<p>L1 Handle IP994 96mm - Pvc 3 pcs</p> 	<p>L2 P/H Screw M4 x 40mm 6 pcs</p> 	<p>M Plastic Pin 24 pcs</p> 	<p>N Allen Key 1 pc</p> 	<p>O1 Drawer Slide - A 400mm 6 pcs</p>  <p><small>* Fix On Panels # 5 & 7</small></p>	<p>O2 Drawer Slide - B 400mm 6 pcs</p>  <p><small>* Fix On Drawer Side Panels</small></p>





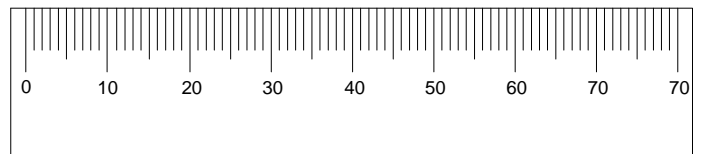

IMPORTANT

Check the measure of the bolts on the scale below or with a measuring tape before applying them in the parts

Observe correctly the application and the position of each bolt accessory, as the step-by-step instructions, before applying them in the parts.



Required Or Recommended Tools

<p>Sample Screwdriver</p> 	<p>Sample Hammer</p> 	<p>Sample Measuring Tape</p> 	<p>Sample Electric Screwdriver</p> 
---	--	---	--



IMPORTANT !

The required or recommended tools for assembly are not supplied with the product.



Hodedah
www.hodedah.com
[support @hodedah.com](mailto:support@hodedah.com)

- This product contains small components, please ensure that they are kept away from small children.
- THIS INSTRUCTION BOOKLET CONTAINS IMPORTANT SAFETY INFORMATION. PLEASE READ AND KEEP FOR FUTURE REFERENCE.

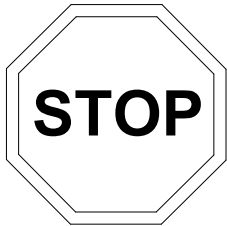

DO NOT RETURN PRODUCT TO THE STORE.

If a part is missing or damaged, email our customer service. We will gladly ship your replacement parts FREE of charge.

Need Parts or Assistance?

email us at

support@hodedah.com

For prompt, reliable service; please have your assembly manual ready.



Hodedah
www.hodedah.com
[support @hodedah.com](mailto:support@hodedah.com)

Thank you for purchasing from Hodedah

To learn more about hodedah and our products visit
www.hodedah.com

READ BEFORE BEGINNING ASSEMBLY

- Read each step carefully. It is very important that each step of instruction is performed in the correct order. If these steps are not followed in sequence, assembly difficulties will occur.
- Make sure all parts are included. Most parts are labeled or stamped on the raw edge.
- Work in spacious area, preferably on a carpet, near the place the unit will be used.
- Do not use power tools to assemble your furniture. Power tools may strip or damage the parts.

HELPFUL HINTS

- Call us if you need assistance.
- Move your new furniture carefully, with two people lift and carry the unit to it's new location.
- Never push, drag or pull your furniture (especially on carpet).

Warranty Information

Hodedah warrants this product to be free from defects in material and workmanship agrees to remedy any such defect. This warranty covers one year from the date of original purchase. This is solely limited to be repair or replacement of defective parts and no assembly labor is included.

This warranty does not apply to any product which has been improperly assembled, subjected to misuse or abuse or which has been altered or repaired in any way.

To obtain warranty, purchaser must present original bill of sale. Components repaired or replaced warranted through the remainder of the original warranty period only. The defective components will be repaired or replaced without charge, subject to the terms and conditions described above.

For help with assembly, identifying parts, product information or to order parts, please contact us :

Call us at :
718-456-0505
Monday - Friday
9:00am - 5:00pm

Visit our website :
www.hodedah.com

Pre - Assembly

Insert 4 Pvc Dowel A into the edge of Panel #1, 4 & 6 where are non-thru holes indicators, using hammer gently tap them in.

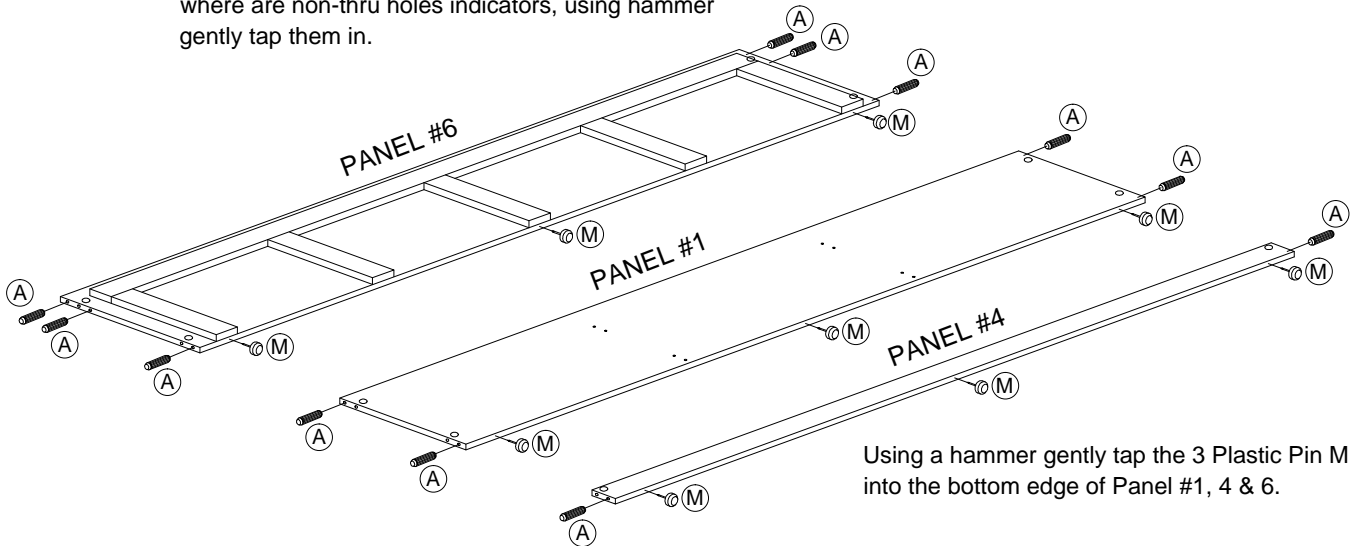

Using a hammer gently tap the 3 Plastic Pin M into the bottom edge of Panel #1, 4 & 6.

Insert Pvc Dowel A into the edge of Panel #13, 16 & 17 where are non-thru holes indicators, using hammer gently tap them in.

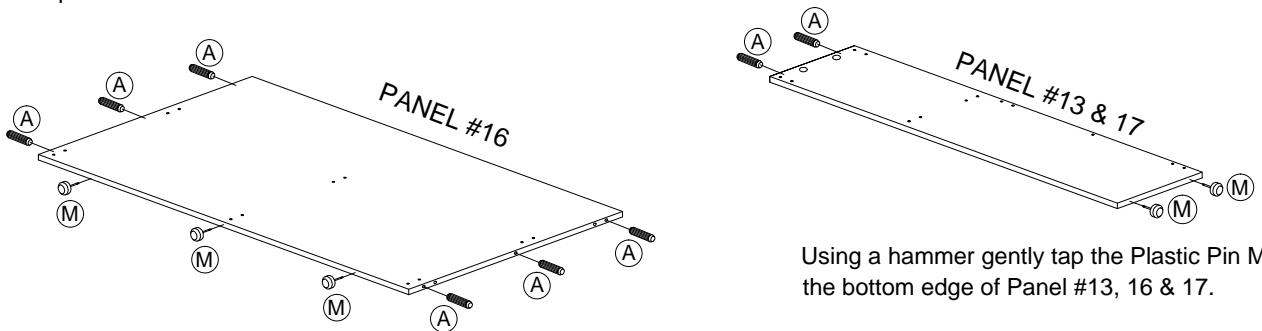

Using a hammer gently tap the Plastic Pin M into the bottom edge of Panel #13, 16 & 17.

Insert Pvc Dowel A into the edge of Panel #15 where are non-thru holes indicators, using hammer gently tap them in.

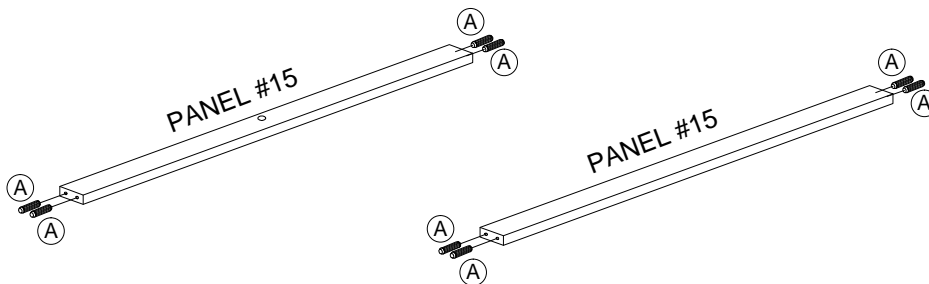

Pre - Assembly

Insert 4 Pvc Dowel A into the edge of Panel #2, 5 & 7 where are non-thru holes indicators, using hammer gently tap them in.

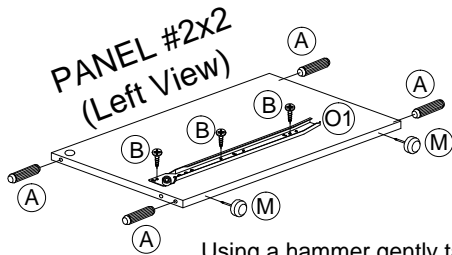

Using a hammer gently tap the 3 Plastic Pin M into the bottom edge of Panel #9, 11 & 13.

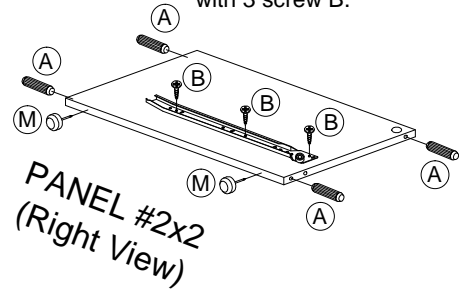

Place the drawer slide O1 onto the 3 marking area shown at side Panel #2. Then tighten it with 3 screw B.

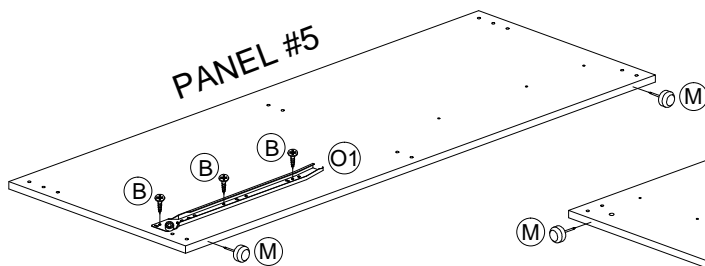

Using a hammer gently tap the 3 Plastic Pin M into the bottom edge of Panel #2, & 5.

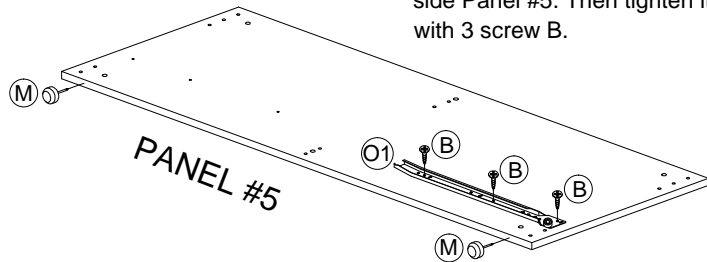

Place the drawer slide O1 onto the 3 marking area shown at side Panel #5. Then tighten it with 3 screw B.

Insert 4 Pvc Dowel A into the edge of Panel #3 where are non-thru holes indicators, using hammer gently tap them in.

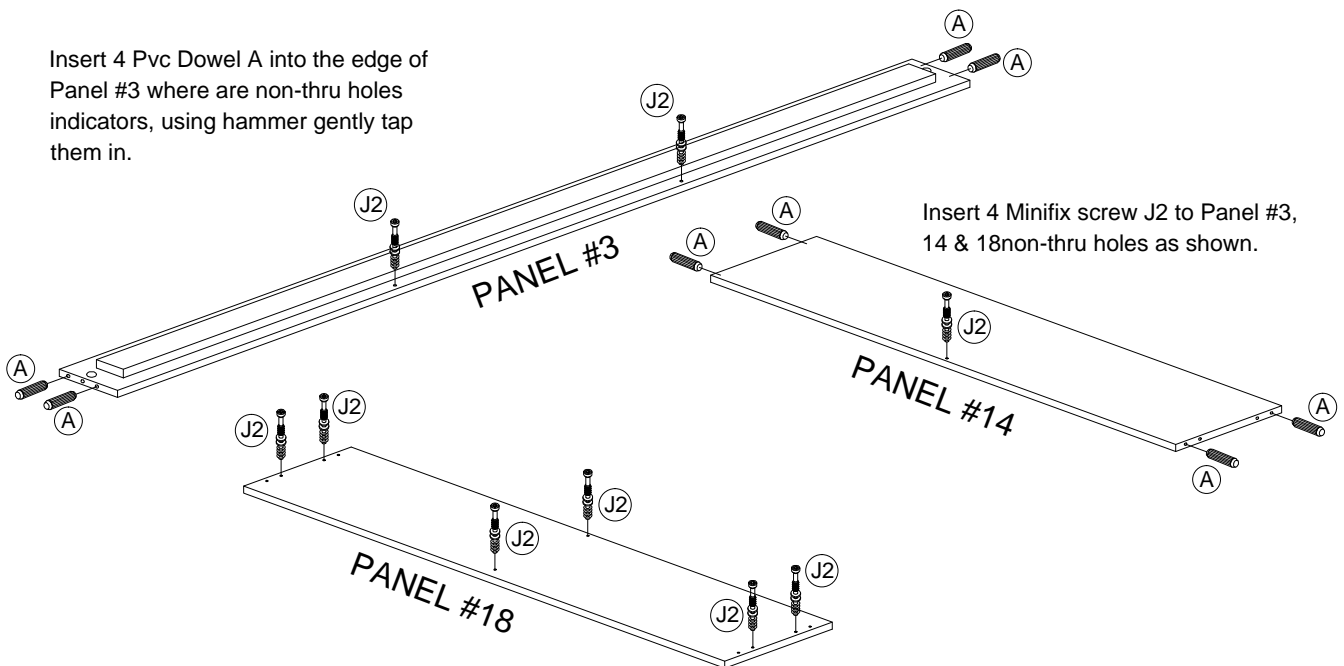

Insert 4 Minifix screw J2 to Panel #3, 14 & 18 non-thru holes as shown.

Assembly Of Drawer

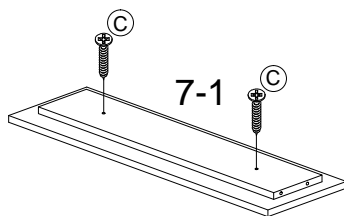

(1)

- Tighten 2 screw C to Panel #7-1 inner thru hole.
- Repeat same step for next Panel #7-2 & 7-3.

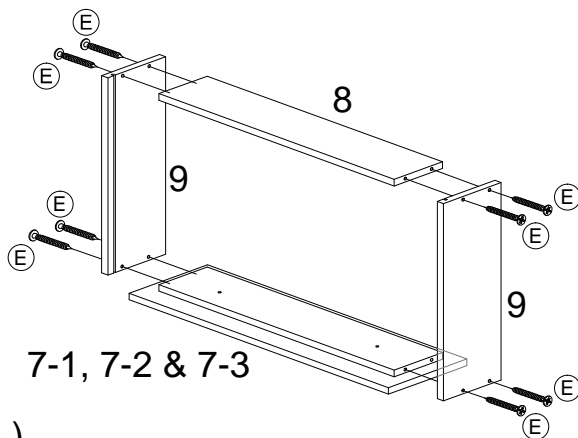

(2)

- Place Panel #7-1 on each side of Panel #9 as shown.
- Then, tighten screw F to Panel #9 lower thru holes to fix them onto Panel #7-1.
- Place Panel #8 on upper side of Panel #9 as shown.
- Next tighten screw E to Panel #9 upper thru holes to fix up to the Panel #8.

(3)

- Flip drawer upside down, place Panel #10 onto the edges of Panel #9. Then, use Nails I & gently hammer the borders of Panel #8 spacing it every 3 to 4 inches.

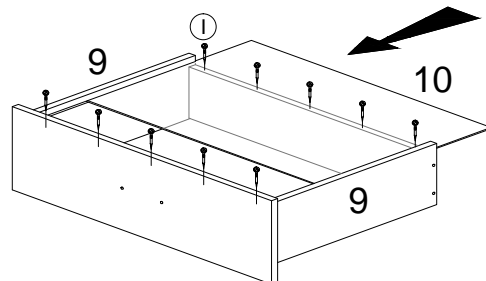

(4)

- Place the Drawer Slide O2 with small white roller facing outward and the end of the tip touching opposite panel. Then tighten each 3 screws B on side Panel #9.
- Place Panel #11 into the drawer base and tighten screw E to fix up to the Panel #7 & 8.

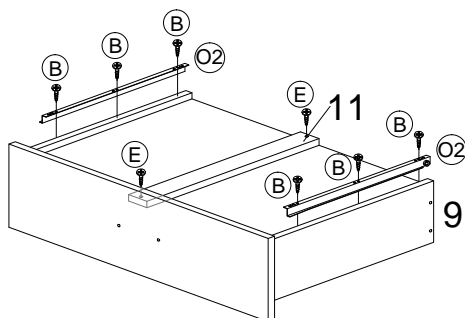

(5)

7-1, 7-2 & 7-3

- Flip the drawer over.
- Tighten 2 screw L2 from inner side of Panel #7-1, 7-2 & 7-3 into the Handle L1 holes.

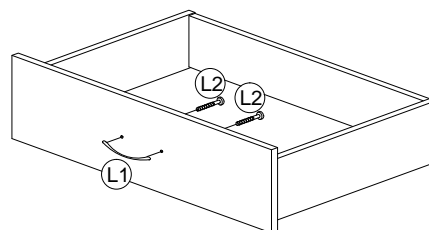

COMPLETED

Assembly Instruction Set A Step 1

- Fix both Panel #2 onto Panel #1 by inserting the dowels onto the respective non-thru holes at Panel #1.
- Use Allen Key N to tighten 4 screw F from the thru-holes of Panel #1 to non-thru hole of both Panel #2, as shown.

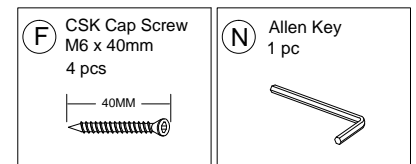
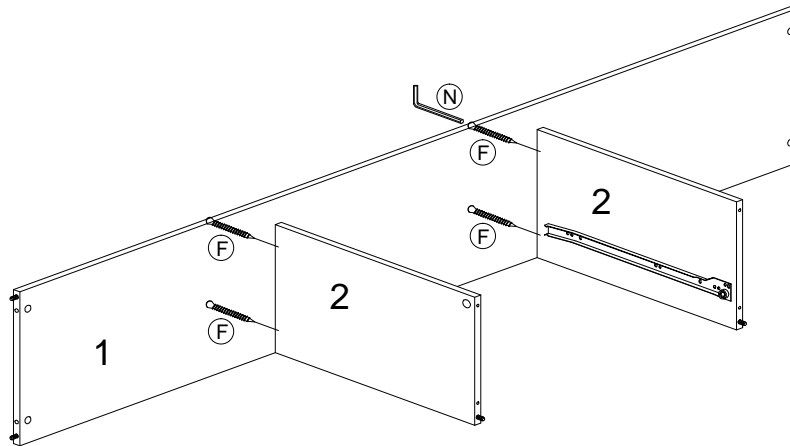

- Fix Panel #3 onto Panels #2 upper . Align properly by inserting the dowel of Panel #3 onto non-thru holes of Panels #2.
- Pushing & light tapping of Panel #3 to have Panel #2 & 3 fix tightly.
- Insert 2 Minifix Housing J1 onto non-thru holes at Panel #2.
- Fix Panel #4 onto Panels #2 lower. Align properly by inserting the dowel of Panel #4 onto non-thru holes of Panels #2.
- Pushing & light tapping of Panel #4 to have Panel #2 & 4 fix tightly.
- Insert 2 Screw G onto thru holes at Panel #4. Use Allen key P to tighten all the Screws G & Minifix J1.

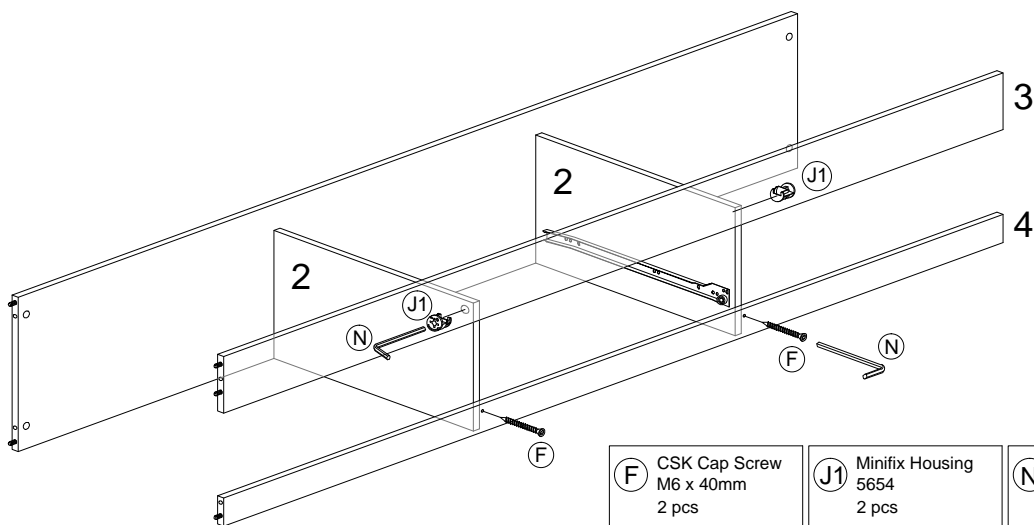

CAUTION

When inserting the Dowels to non-thru holes, don't push to hard. Otherwise, the side panels (2) may be damage.

Assembly Instruction Set A Step 2

- Fix Panel #5 onto Panel #1 by inserting the dowels onto the respective non-thru holes at Panel #1.
- Insert 2 Barrel Nuts H to non-thru holes at Panel #1, 3 & 4.
- Use Allen Key N to tighten 4 screw G from the thru-holes of Panel #5 to non-thru hole of both Panel #1, 3 & 4, as shown.

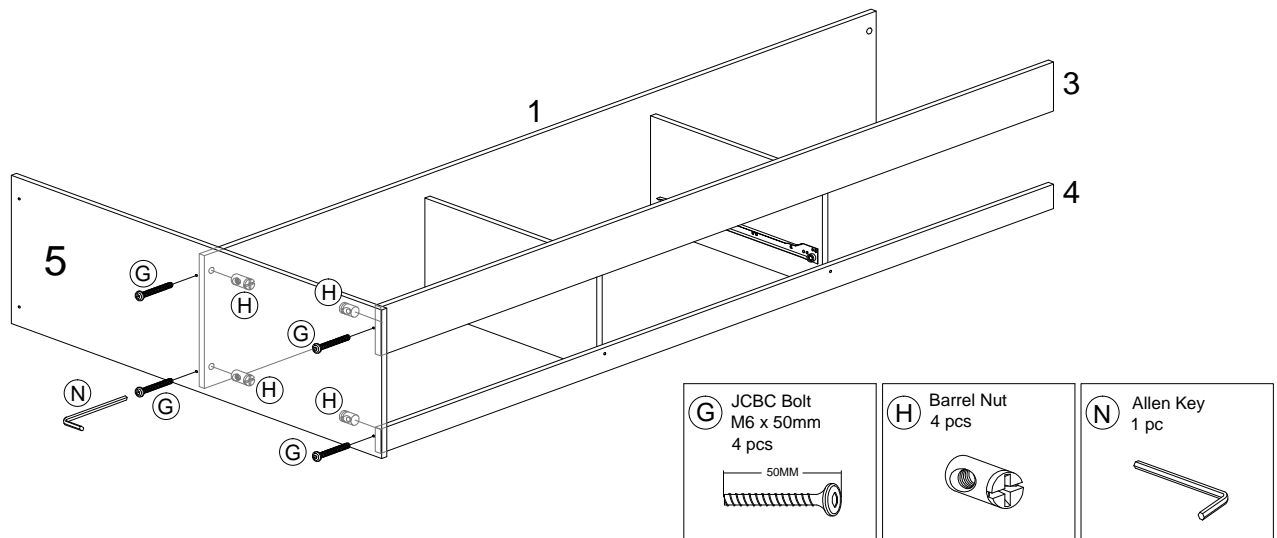

- Fix Panel #6 onto Panels #5. Align properly by inserting the dowel of Panel #6 onto non-thru holes of Panels #5.
- Pushing & light tapping of Panel #6 to have Panel #6 fix tightly.
- Insert 2 Barrel Nuts H to non-thru holes at Panel #6.
- Then, insert 2 Screw G onto thru holes at Panel #5. Use Allen key N to tighten all the Screws G.

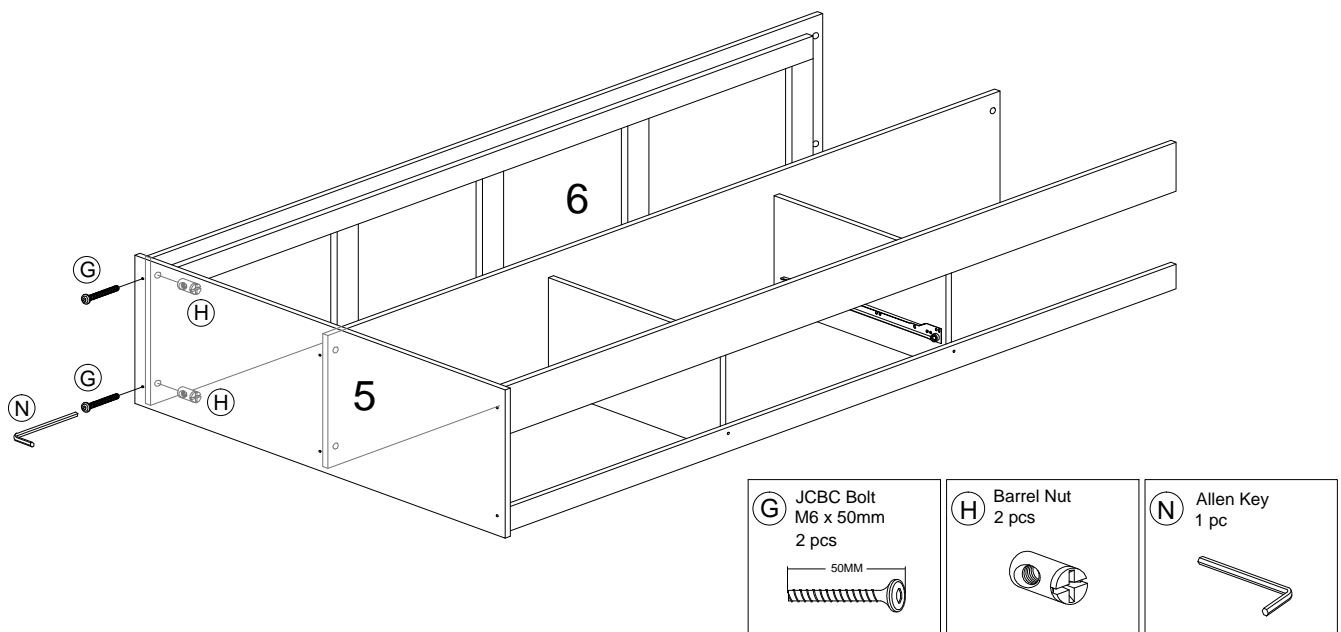

CAUTION

When inserting the Dowels to non-thru holes, don't push to hard. Otherwise, the side panels (1, 3, 4 & 6) may be damage.

Assembly Instruction Set A Step 3

- Fix Panel #5 onto Panels #1, 3, 4 & 6. Align properly by inserting the dowel of Panel #1, 3, 4 & 6 onto non-thru holes of Panels #5.
- Pushing & light tapping of Panel #5 to have Panel #1, 3, 4, 5 & 6 fix tightly.
- Insert 6 Barrel Nut H onto non-thru holes at Panel #1, 3, 4 & 6.
- Then, insert 6 Screw G onto thru holes at Panel #5. Use Allen key N to tighten all the Screws G.

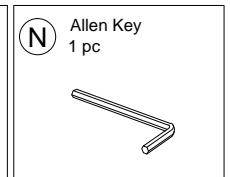
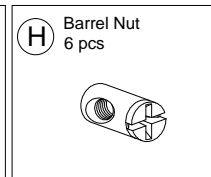
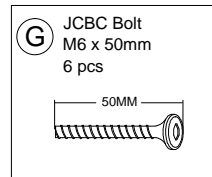
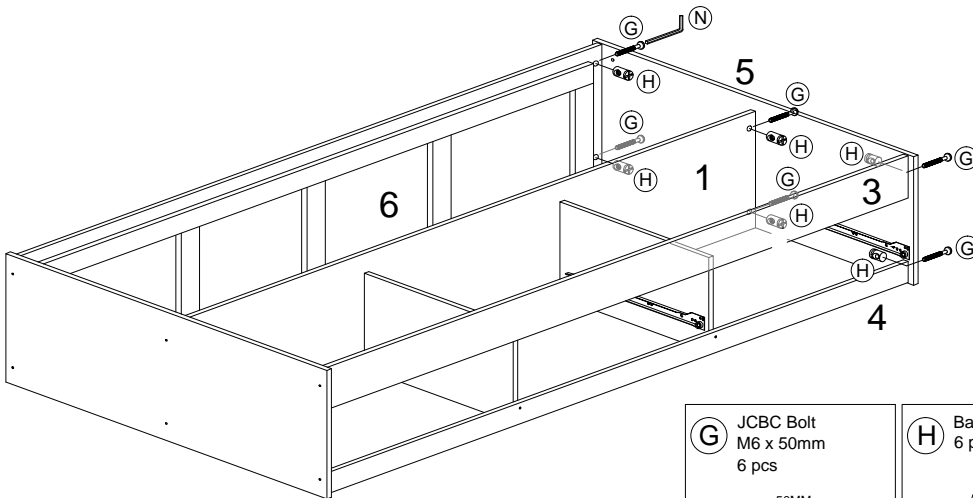

- Place 4 Panels #12 onto the middle of bed.
- Insert screw E onto the thru holes at Panel #12.

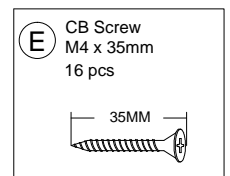
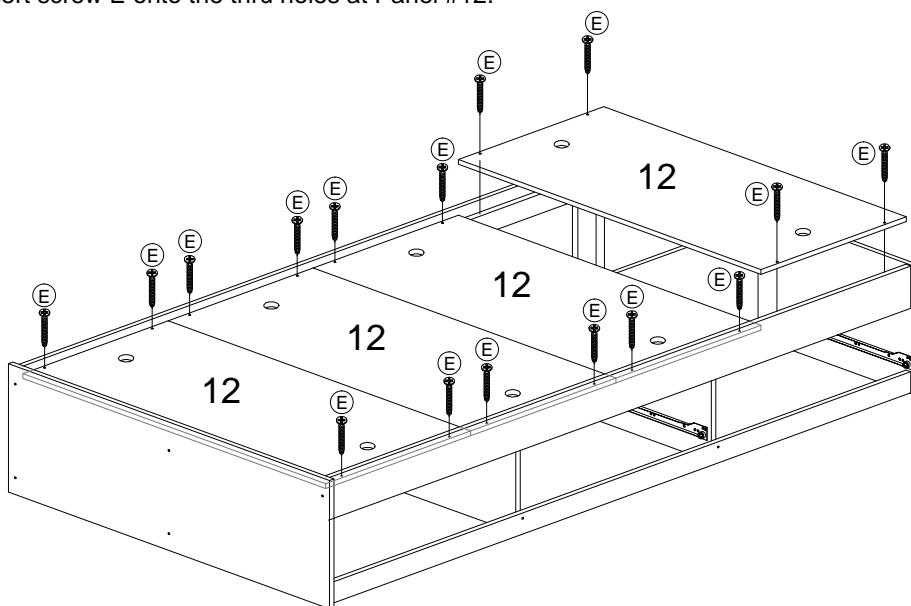

CAUTION

When inserting the Dowels to non-thru holes, don't push to hard. Otherwise, the side panels (1, 3, 4 & 6) may be damage.

Assembly Instruction Set B Step 1

- Fix Panel #15 onto Panel #13 by inserting the dowels onto the respective non-thru holes at Panel #13.
- Next, fix Panel #14 onto Panel #13 by inserting the dowels onto the non-thru holes at panel #13.
- Use Allen Key N to tighten 2 screw F from the thru-holes of Panel #13 to non-thru hole of Panel #14, as shown.

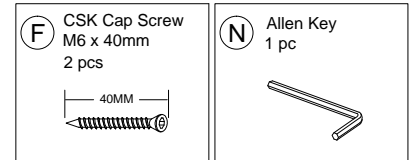
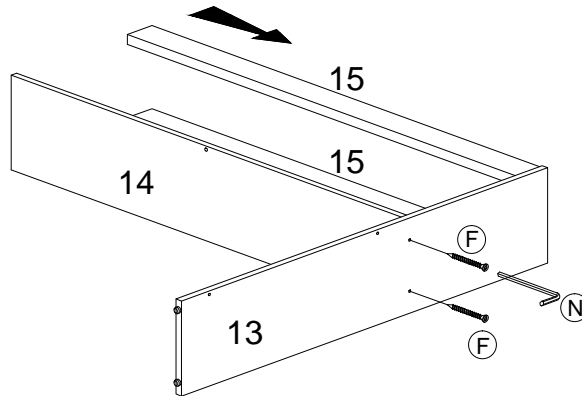

- Fix Panel #16 onto Panels #13. Align properly by inserting the dowel of Panel #16 onto non-thru holes of Panel #13.
- Pushing & light tapping of Panel #16 to have Panel #16 & 13 fix tightly.
- Insert 2 screw F onto thru holes at Panel #13.
- Fix Panel #15 & 16 onto Panels #17. Align properly by inserting the dowel of Panel #15 & 16 onto non-thru holes of Panel #17.
- Insert 4 screw F onto thru holes at Panel #19.

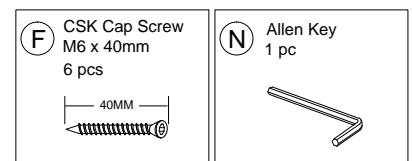
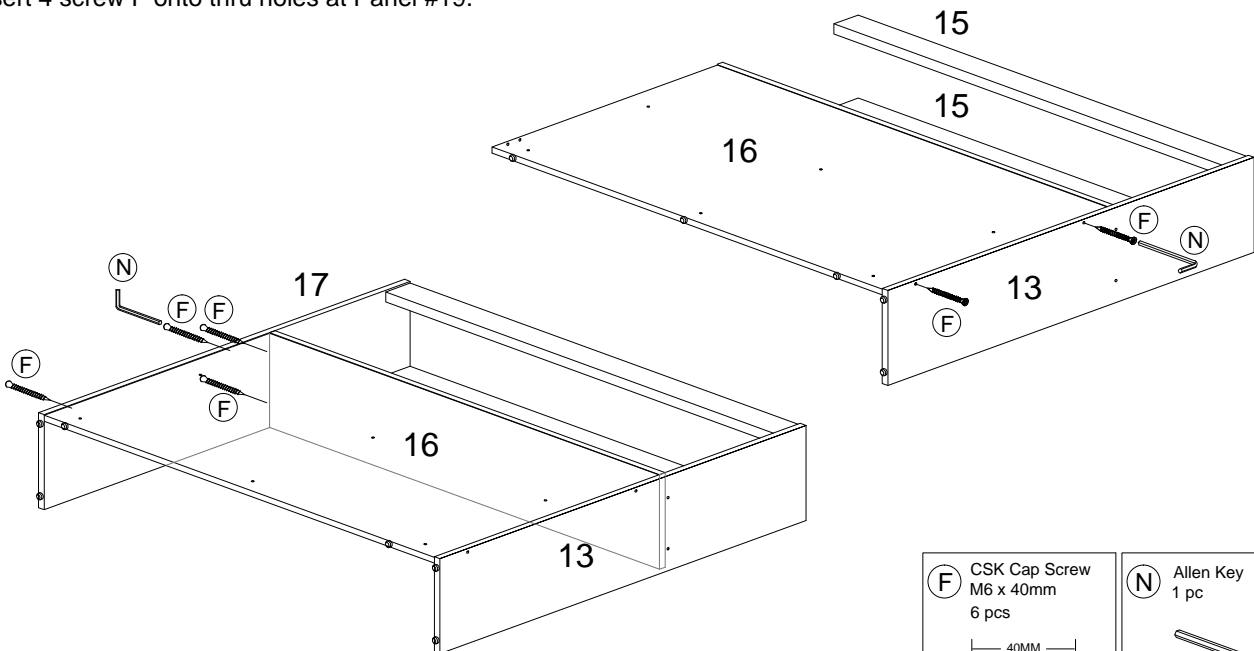

CAUTION

When inserting the Dowels to non-thru holes, don't push to hard. Otherwise, the side panels (15, 14 & 16) may be damage.

Assembly Instruction Set B Step 2

- Lift up the unit & fix Panel #18 by inserting the dowels onto the non-thru holes at Part #18.
- Insert Minifix Housing J1 onto non-thru holes at Panel # 13 & 17.
- Use Allen Key N to tight 6 Minifix Housing J1 from the non-thru holes at Panel #13 & 17.

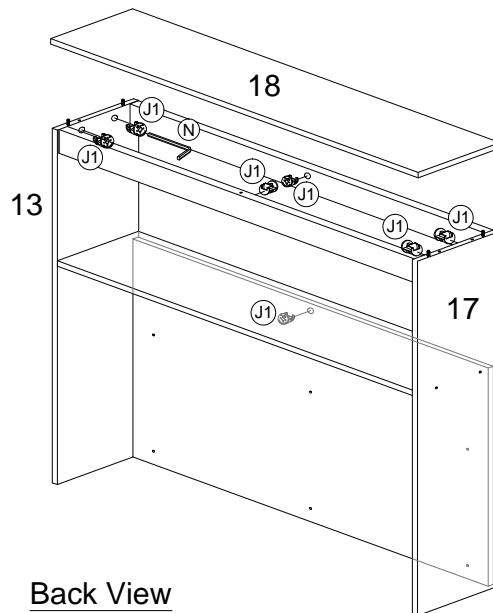

Back View

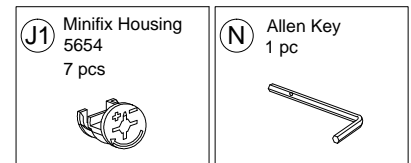

- Place Panel #19 onto back of the completed set B.
- Then, align the Panel #19 properly for nailing.
- Use a hammer to nail the 28pcs of nails I one by one of 4 side edges. Gap between 2 nails should be about 100mm for all.

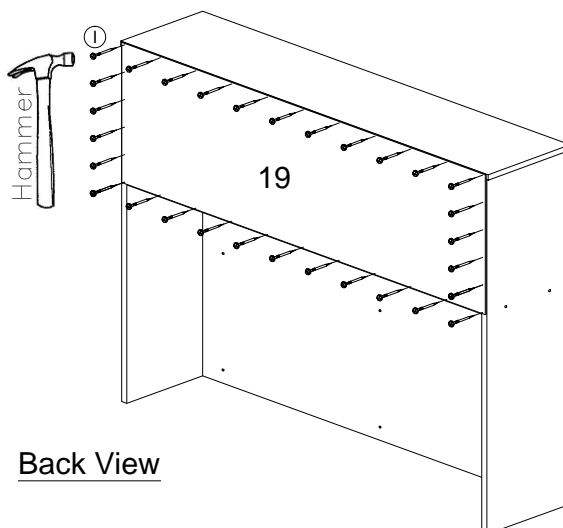

Back View

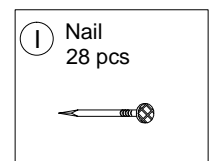

CAUTION

When inserting the Dowels to non-thru holes, don't push to hard. Otherwise, the side panels (13 & 17) may be damage.

Assembly Instruction Set B Step 3

- Joint the completed set A to set B. Insert 6 screw D From the inner of set B.

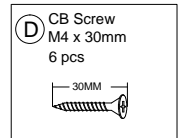
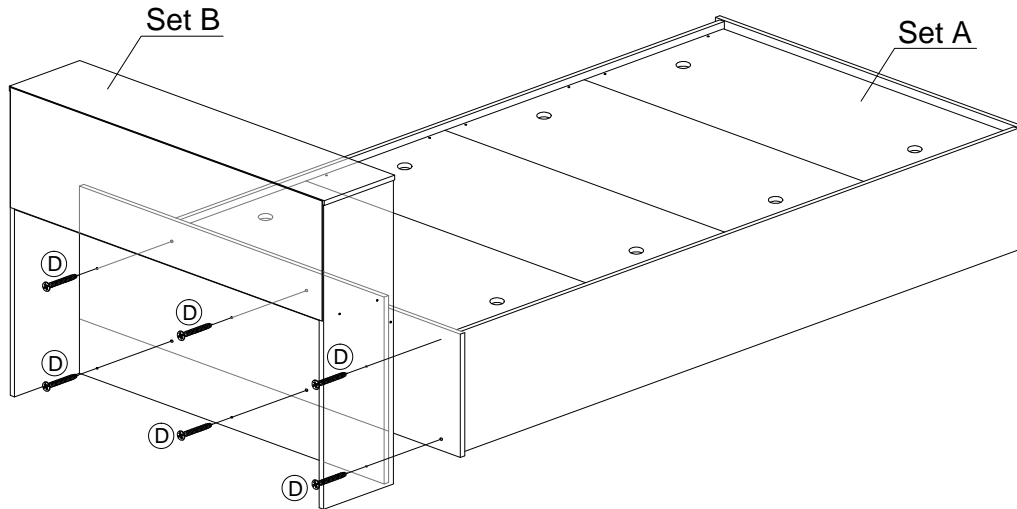

- Take Drawer and slide them (the white rollers at drawer slide at both side of drawers are to go into the track of the slides at each side panel all the way gently.

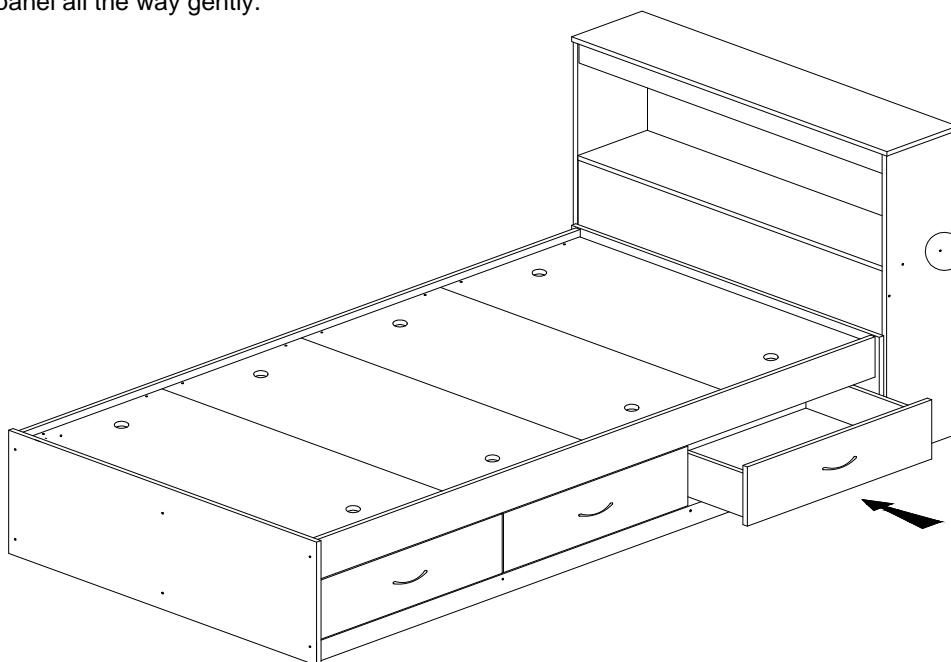

Cover all the screw F and minifix housing J1 head with Pvc cap K provided by pushing cover's stem onto the hole of screw heads one by one for all screws.

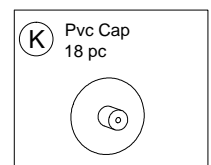

Completion

In the interest of our environment please dispose of all packaging thoughtfully.