

ASSEMBLY INSTRUCTIONS

HIK 72 (MOP KITCHEN CABINET)

- ~ Before assembly, please read the instructions ~ ~ Follow these steps to assemble the Microwave Cart ~
~ Keep these instructions for future reference ~

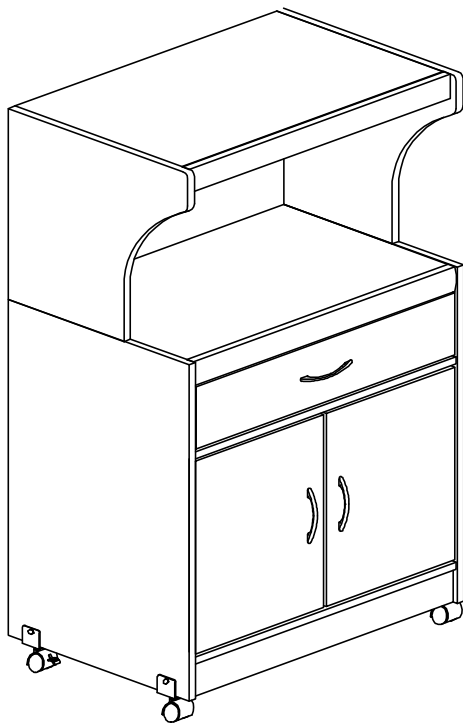

FRONT VIEW

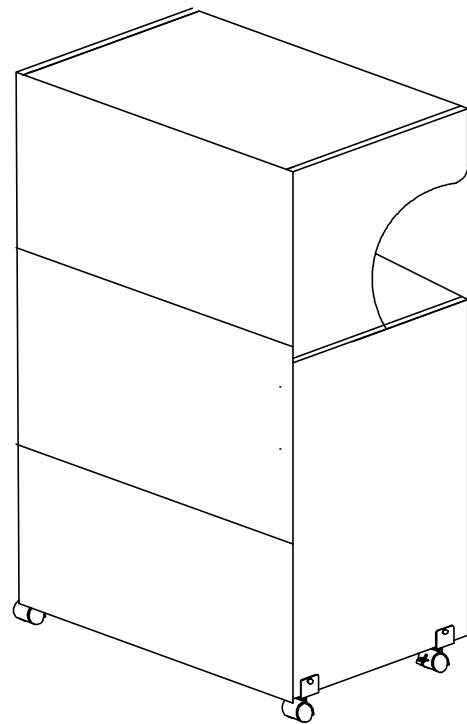

REAR VIEW



THIS INSTRUCTION BOOKLET CONTAINS IMPORTANT INFORMATION ABOUT ASSEMBLY AND SAFETY. PLEASE READ AND KEEP FOR FUTURE REFERENCE.

Parts

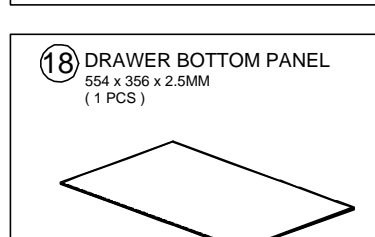
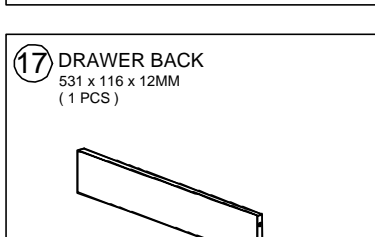
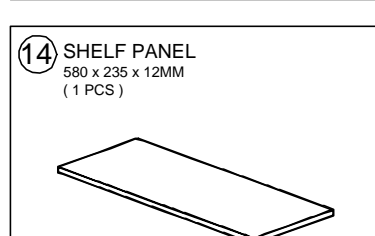
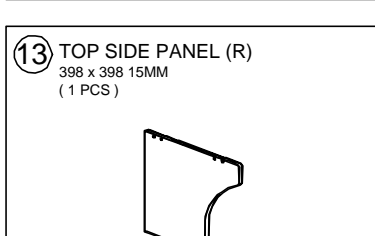
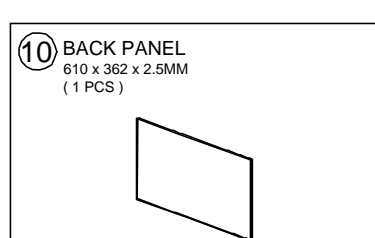
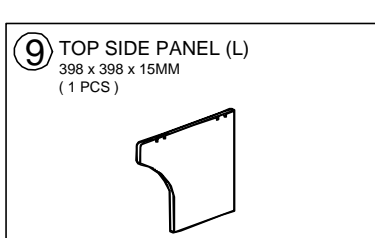
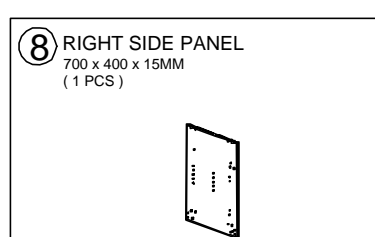
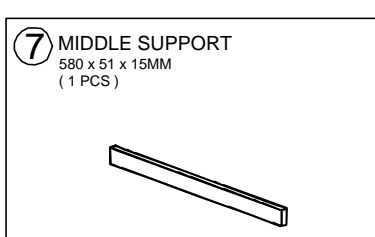
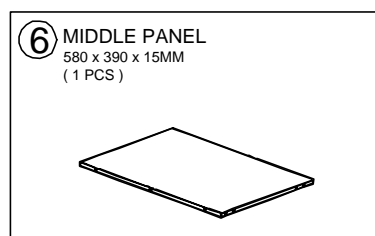
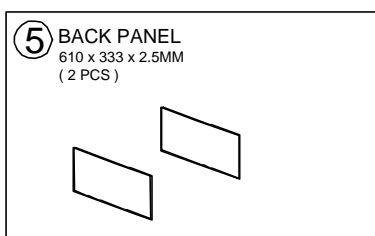
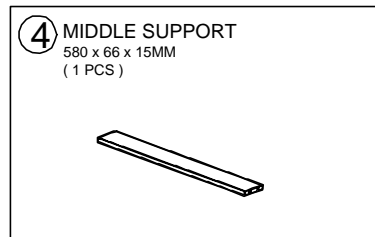
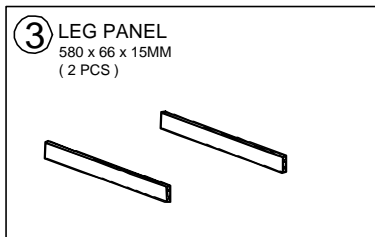
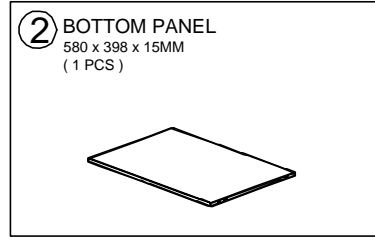
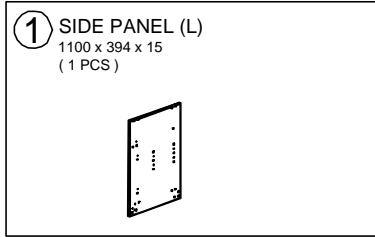

The parts of the product are packed in one box.
These are inner box(es) or package(s) that included components and accessories required to complete the assembly.

I) Main Unit :

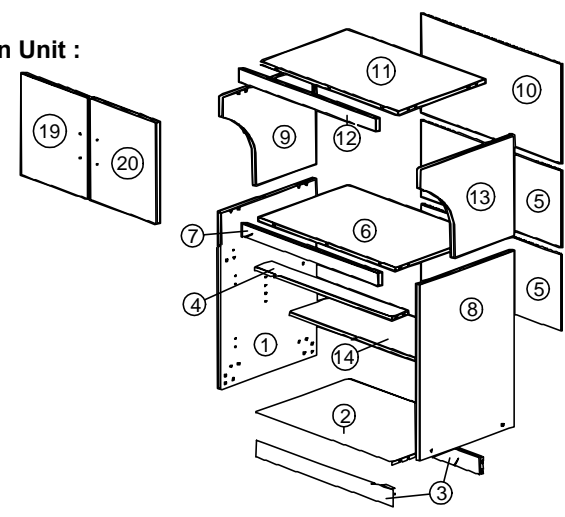

II) Door & Drawer :

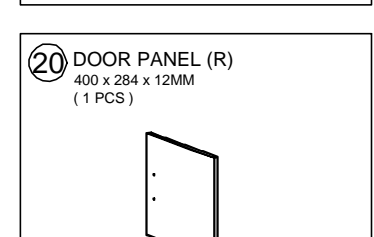
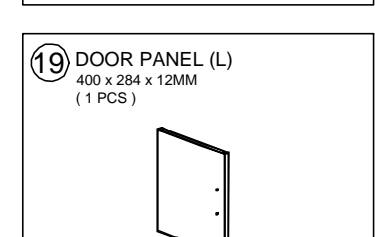
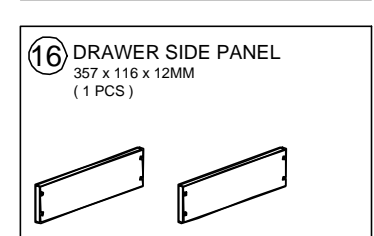
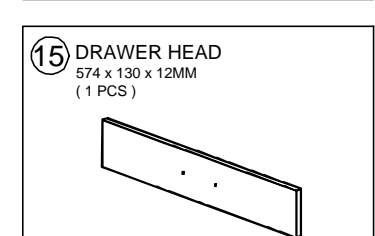
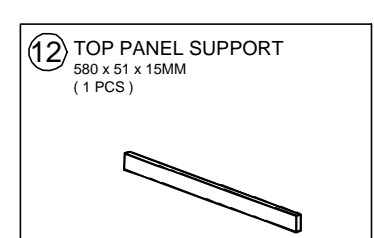
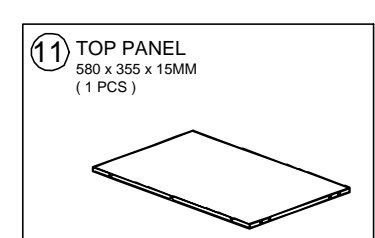
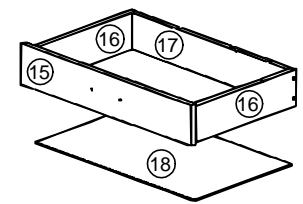

Hardware And Accessories

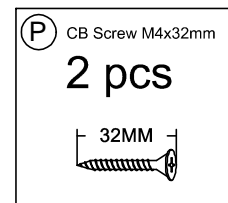
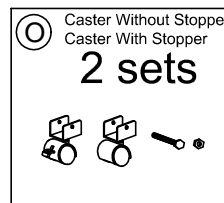
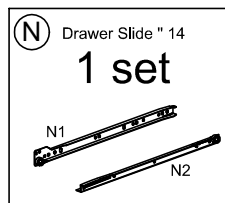
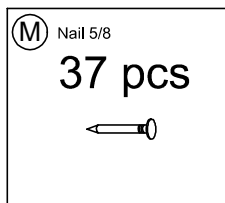
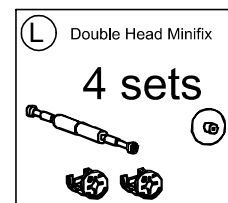
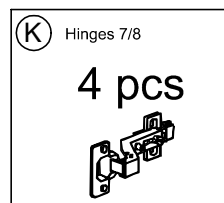
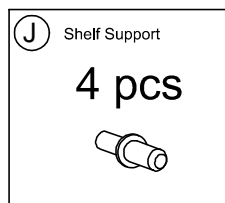
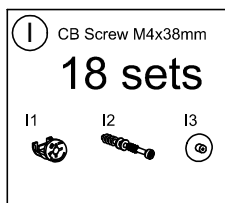
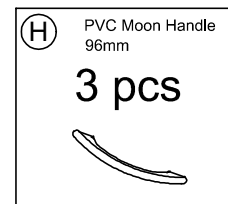
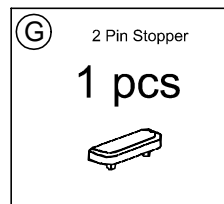
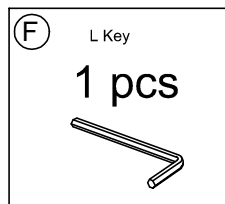
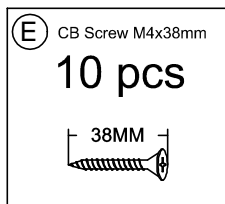
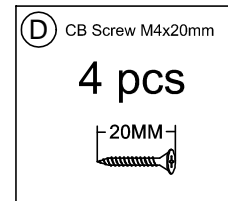
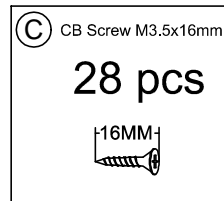
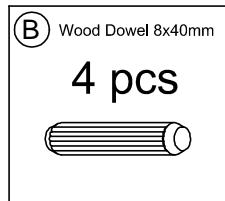
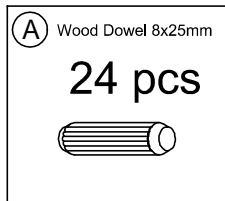

IMPORTANT

Check the measure of the bolts on the scale below or with a measuring tape before applying them in the parts

Observe correctly the application and the position of each bolt accessory, as the step-by-step instructions, before applying them in the parts.

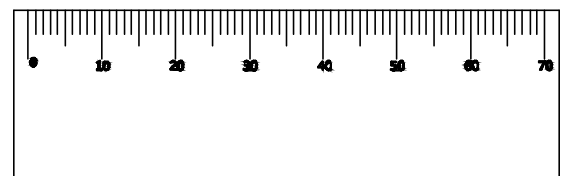

Required Or Recommended Tools

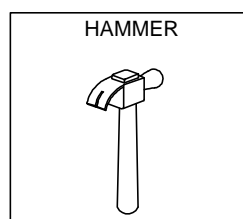
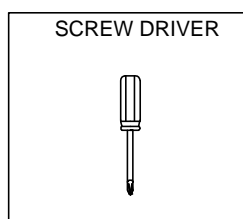

IMPORTANT!

The required or recommended tools for assembly are not supplied with the product



Hodedah

www.hodedah.com
support@hodedah.com

- This product contains small components, please ensure that they are kept away from small children.
- THIS INSTRUCTION BOOKLET CONTAINS **IMPORTANT SAFETY INFORMATION**.PLEASE READ AND KEEP FOR FUTURE REFERENCE.

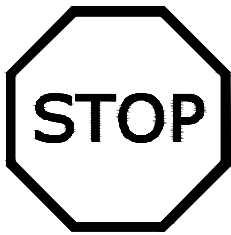

DO NOT RETURN PRODUCT TO THE STORE.

If a part is missing or damaged, email our customer service. We will gladly ship your replacement parts **FREE** of charge.

Need Parts or Assistance?

email us at

support@hodedah.com

For prompt, reliable service; please have your assembly manual ready.

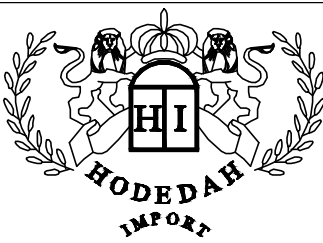

Hodedah

www.hodedah.com
support@hodedah.com

Thank you for purchasing from Hodedah

**To learn more about hodedah and our products visit
www.hodedah.com**

READ BEFORE BEGINNING ASSEMBLY

- Read each step carefully. It is very important that each step of instruction is performed in the correct order. If these steps are not followed in sequence, assembly difficulties will occur.
- Make sure all parts are included. Most parts are labeled or stamped on the raw edge.
- Work in spacious area, preferably on a carpet, near the place the unit will be used.
- Do not use power tools to assemble your furniture. Power tools may strip or damage the parts.

HELPFUL HINTS

- Call us if you need assistance.
- Move your new furniture carefully, with two people lift and carry the unit to its new location.
- Never push, drag or pull your furniture (especially on carpet).

Warranty Information

Hodedah warrants this product to be free from defects in material and workmanship agrees to remedy any such defect. This warranty covers one year from the date of original purchase. This is solely limited to be repair or replacement of defective parts and no assembly labor is included.

This warranty does not apply to any product which has been improperly assembled, subjected to misuse or abuse or which has been altered or repaired in any way.

To obtain warranty service, purchaser must present original bill of sale. Components repaired or replaced warranted through the remainder of the original warranty period only. The defective components will be repaired or replaced without charge, subject to the terms and conditions described above.

For help with assembly, identifying parts, product information or to order parts, please contact us:

Call us at:
718-456-0505
Monday-Friday
9:00am-5:00pm

Visit our website:
www.hodedah.com

Pre - Assembly

Insert Wood Dowels (A) in
B, C, D, F and K.
Using Hammer To Gently
Tap Them In.

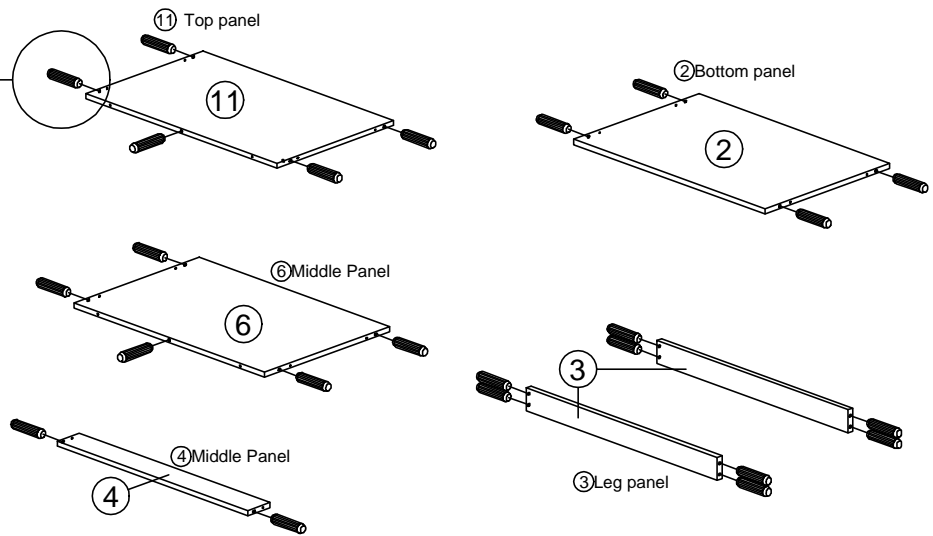
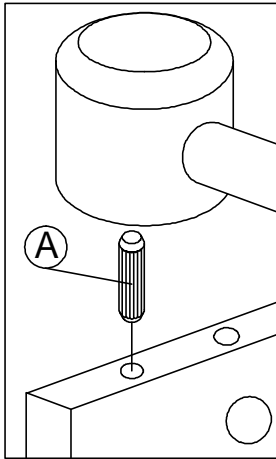

Tighten Minifix (12) To Panel
A, G, H, I, L and M.

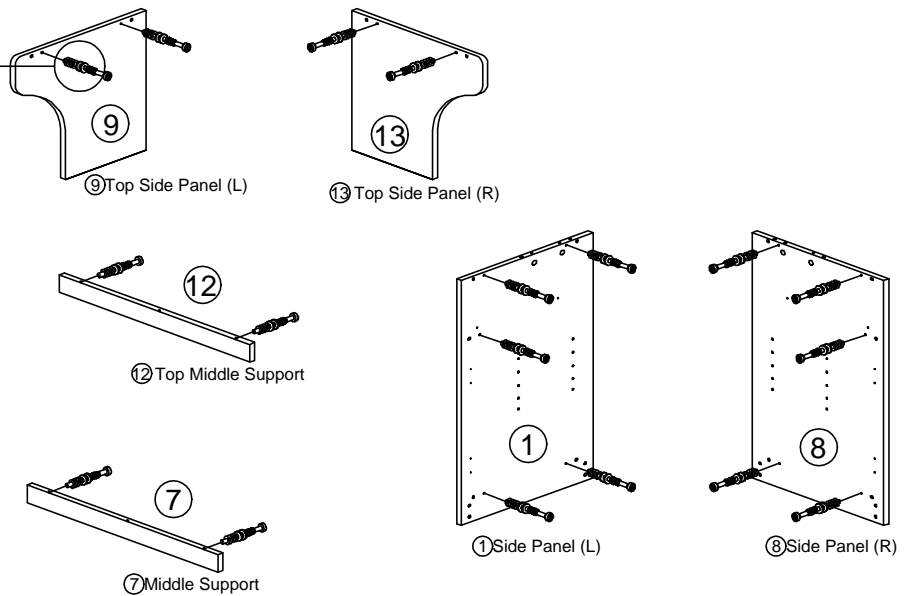
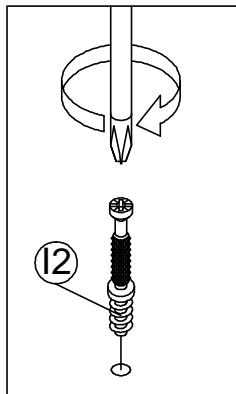

Pre - Assembly

Place The Drawer Slide On To 3 Holes Area Shown At Right Side Panel (1). Then Tighten It With 3 Screw (C).

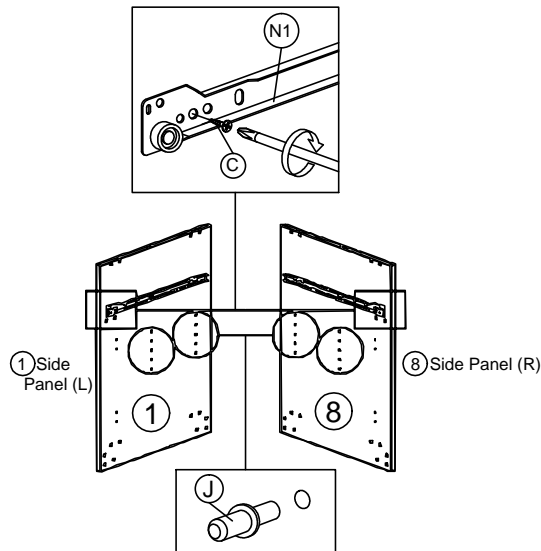

Place The Drawer Slide On To 3 Holes Area Shown At Right Side Panel (8). Then Tighten It With 3 Screw (C).

Insert 2 Shelf Support (J) On Panel (1).

Insert 2 Shelf Support (J) On Panel (8).

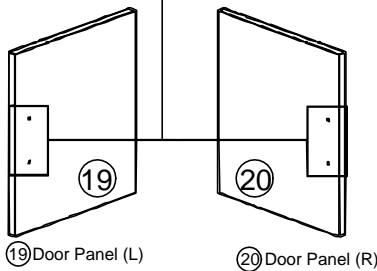
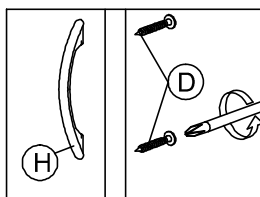

Tighten 2 Screw (D) From Door Panel (19, 20) Into The Handle (H) Hole.

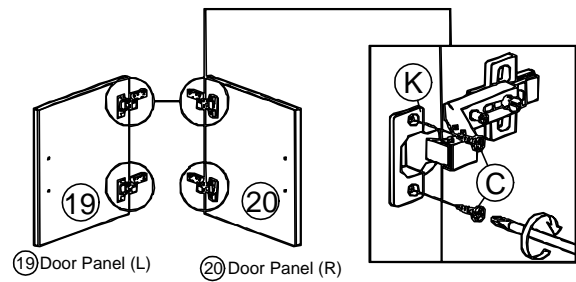

Insert Slot Hinges (K) Into Upper Door Panel (19, 20) Non-Thru Holes As Shown, Then Tighten Screw (C) Through Hinges (K) Thru Hole.

<p>(N1) Drawer Slide " 14</p> <p>2</p>	<p>(J) Shelf Support</p> <p>4</p>	<p>(H) PVC Moon Handle 96mm</p> <p>2</p>
<p>(K) Hinges 7/8</p> <p>4</p>	<p>(C) CB Screw M3.5x16mm</p> <p>14</p>	<p>(D) CB Screw M4x20mm</p> <p>4</p>

Pre - Assembly

STEP 6

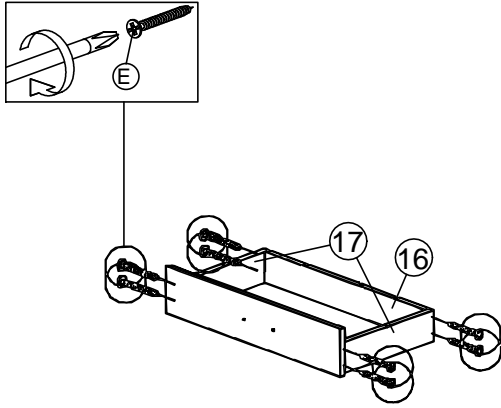

STEP 7

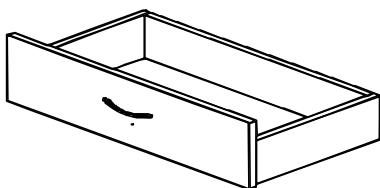
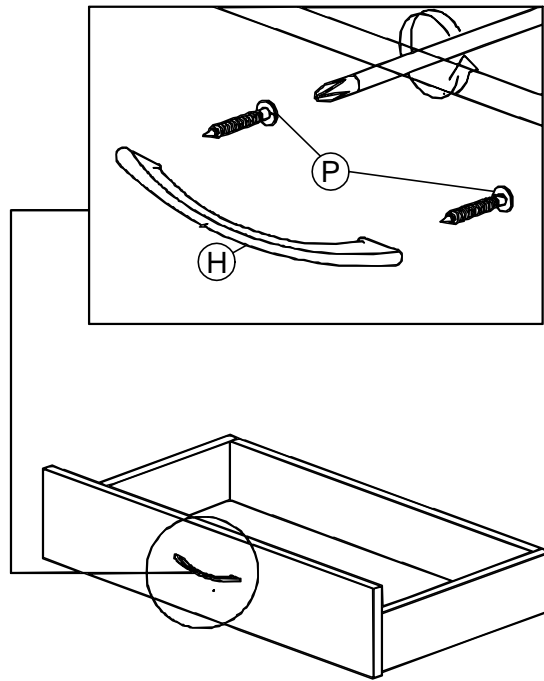
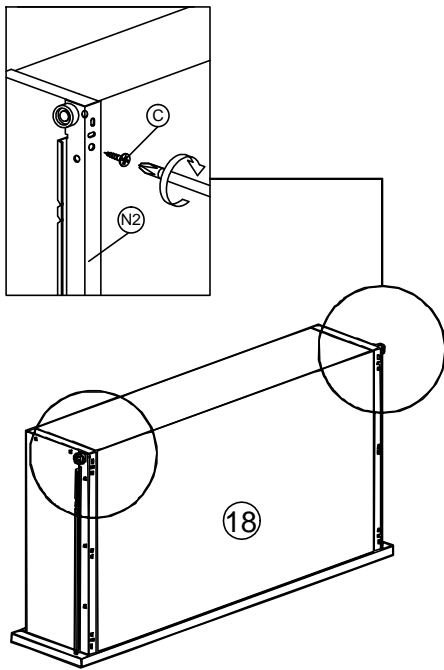
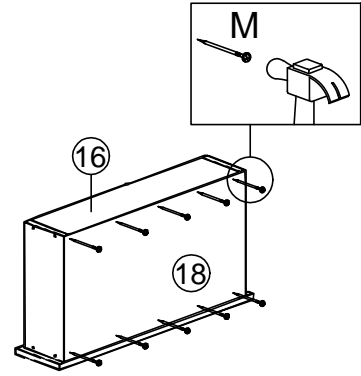

COMPLETED

<p>(E) CB Screw M4x38mm</p> <p>8</p>	<p>(M) Nail 5/8</p> <p>10</p>	<p>(N) Drawer Slide " 14</p> <p>2</p> <p>N2</p>
<p>(H) PVC Moon Handle 96mm</p> <p>1</p>	<p>(C) CB Screw M3.5x16mm</p> <p>6</p>	<p>(P) CB Screw M4x32mm</p> <p>2</p>

Assembly Instruction Step 1

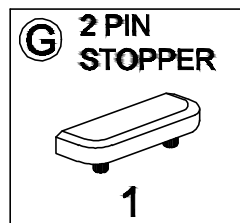
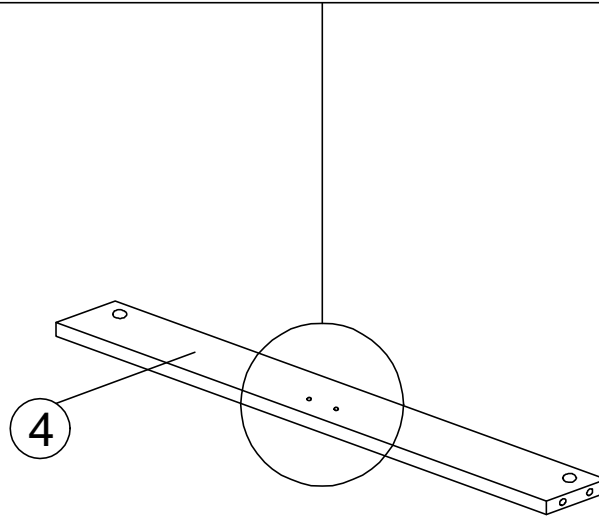
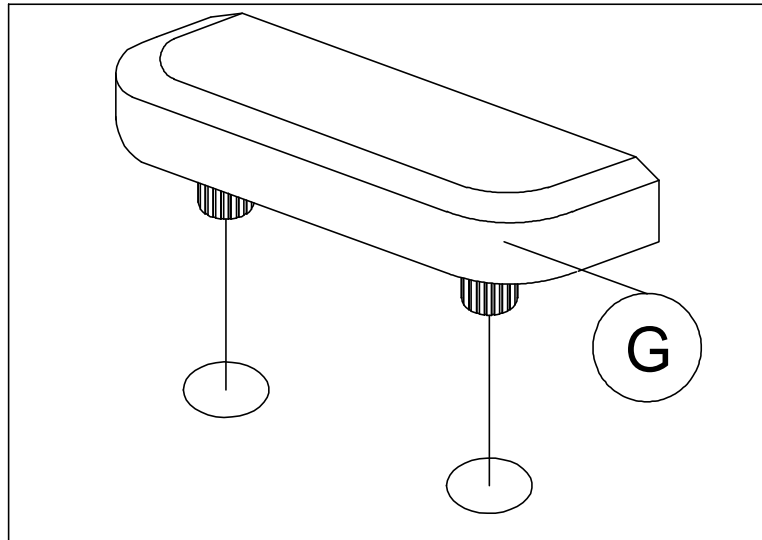

Insert Lower Stopper (**G**) Onto Panel (**4**) 's Non-thru Holes As Shown.

Assembly Instruction Step 2

Fix Panel **(3)** Onto Panel **(1)** By Pushing The 2 (LEFT) Dowels Onto The Non-thru Holes At Lower Corner Area Of Panel **(3)**.

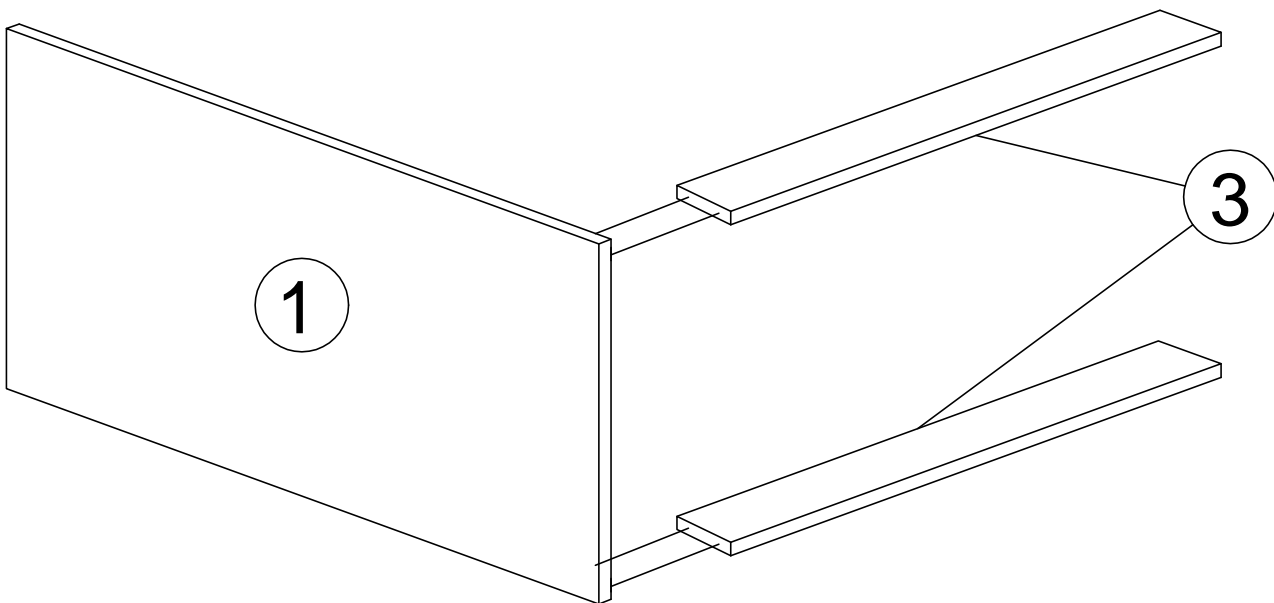

Insert Ter Wood Supporting Panel

Assembly Instruction Step 3

Fix Panel (2,3 and 4) Onto Panel (1) By Inserting Minifix (I1) Into Panel (2,3 and 4)'s L-thru Holes And Using Allen Key (F) To Tighten It After That Insert Minifix Cap (I3).

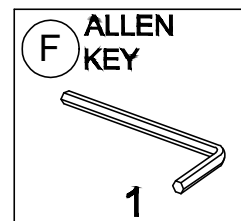
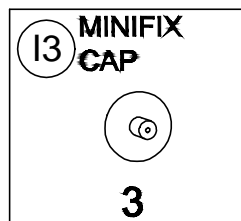
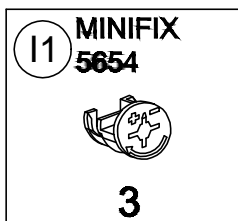
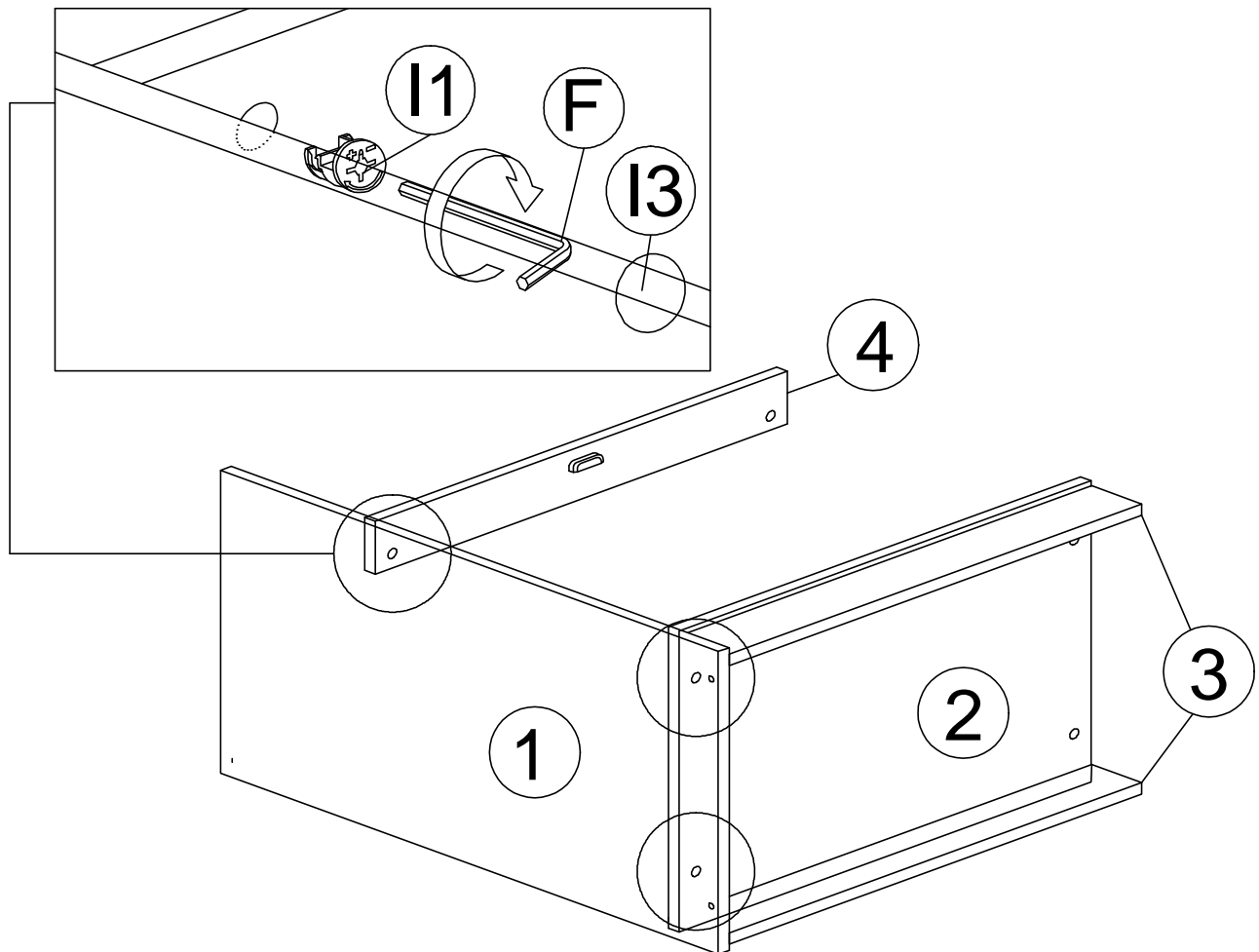

Assembly Instruction Step 4

Fix Panel (6,7) Onto Panel (1) By Inserting Minifix (I1) Into Panel (6,7) 's L-thru Holes And Using Allen Key (F) To Tighten It After That Insert Minifix Cap (I3).

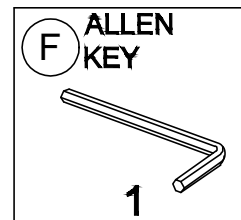
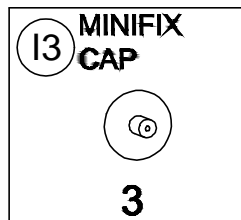
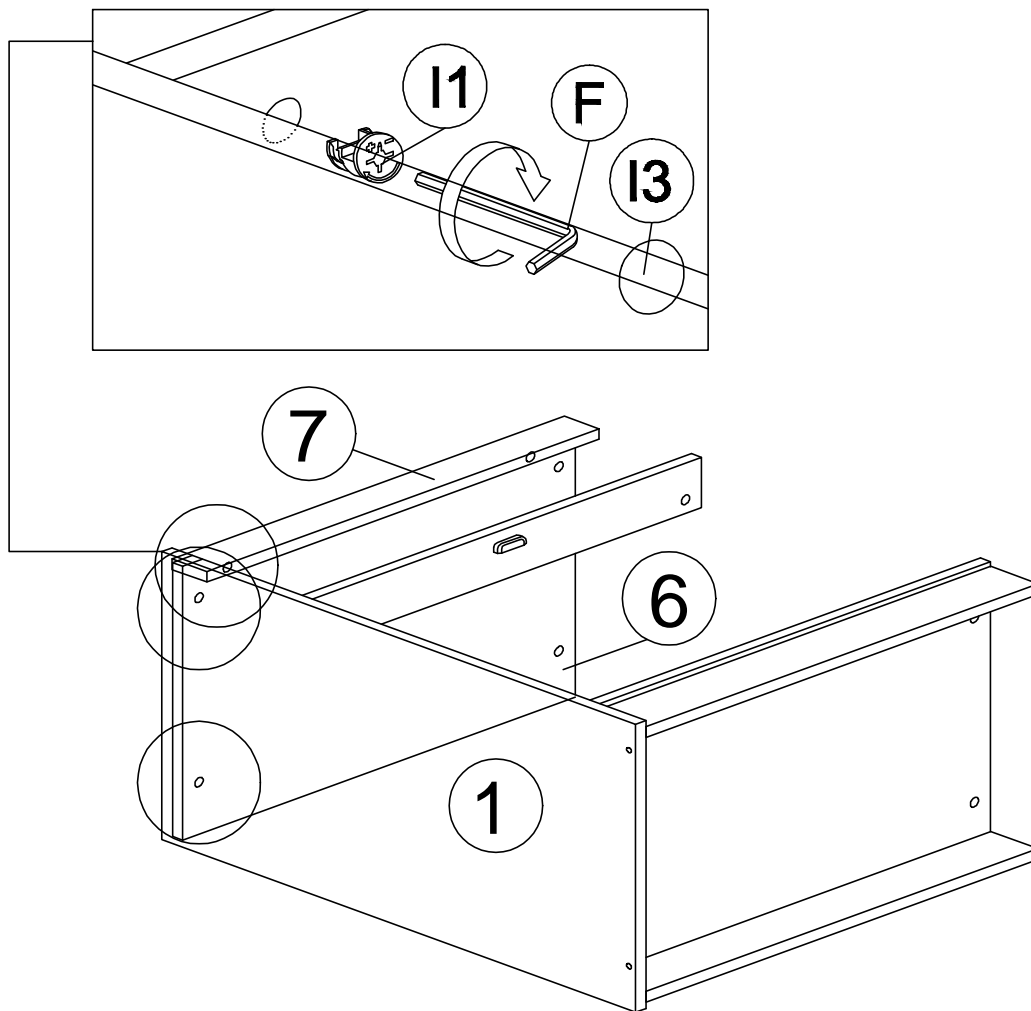

Assembly Instruction Step 5

Fix Panel (2,6 and 7) Onto Panel (8) By Inserting Minifix (I1) Into Panel (2,6 and 7) 's L-thru Holes And Using Allen Key (F) To Tighten It After That Insert Minifix Cap (I3).

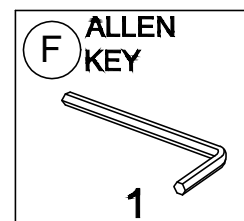
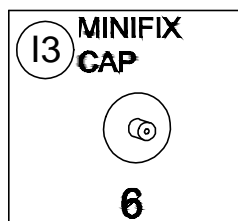
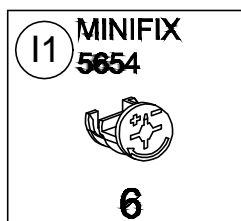
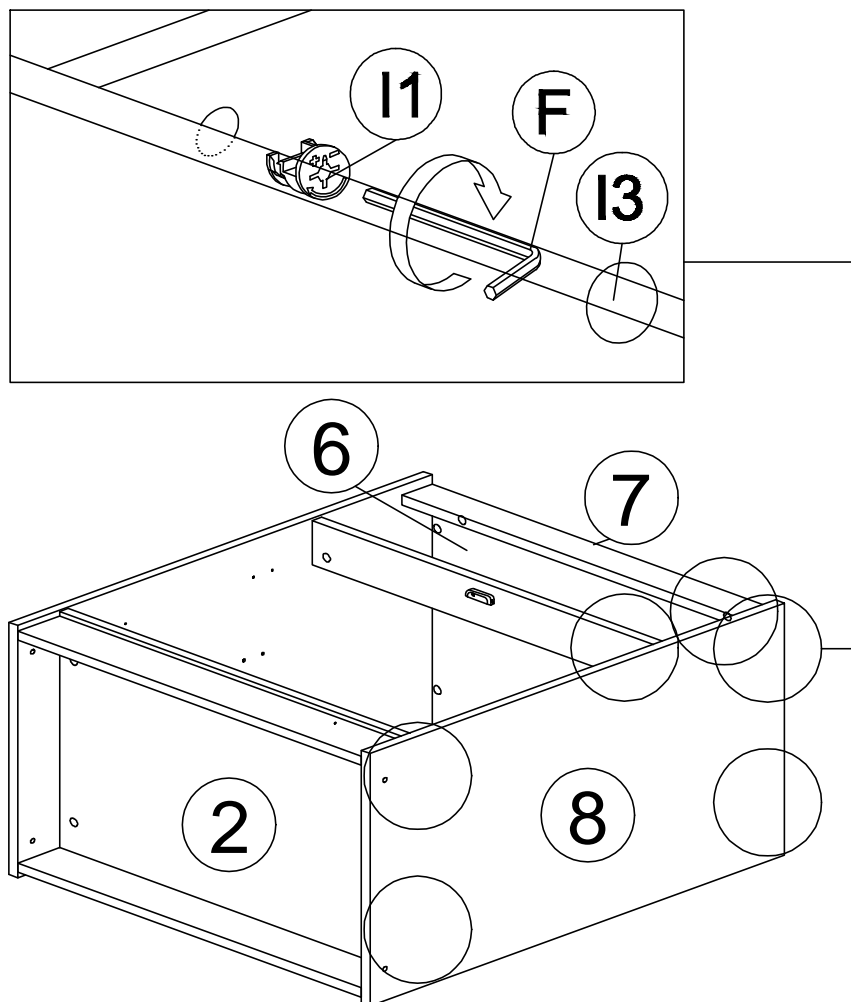

Assembly Instruction Step 6

Take Caster **O1** & **O2** (One By One). Slot The "U" Metal Part Of Caster Onto The Bottom Edge (At Each Corner Area), Insert And Push The Caster's Screw Thru From Outside To Inside To Inside, Then Tighten The Nut As Shown For All 4 Casters.

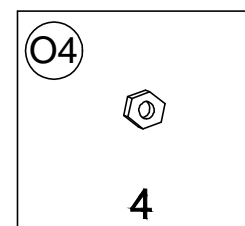
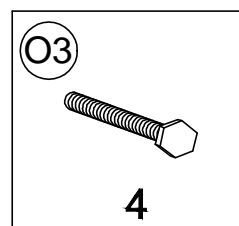
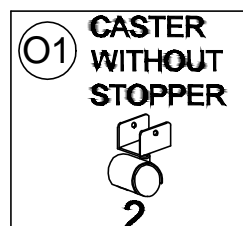
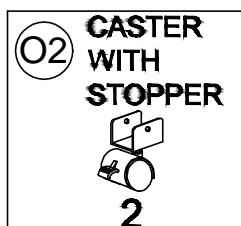
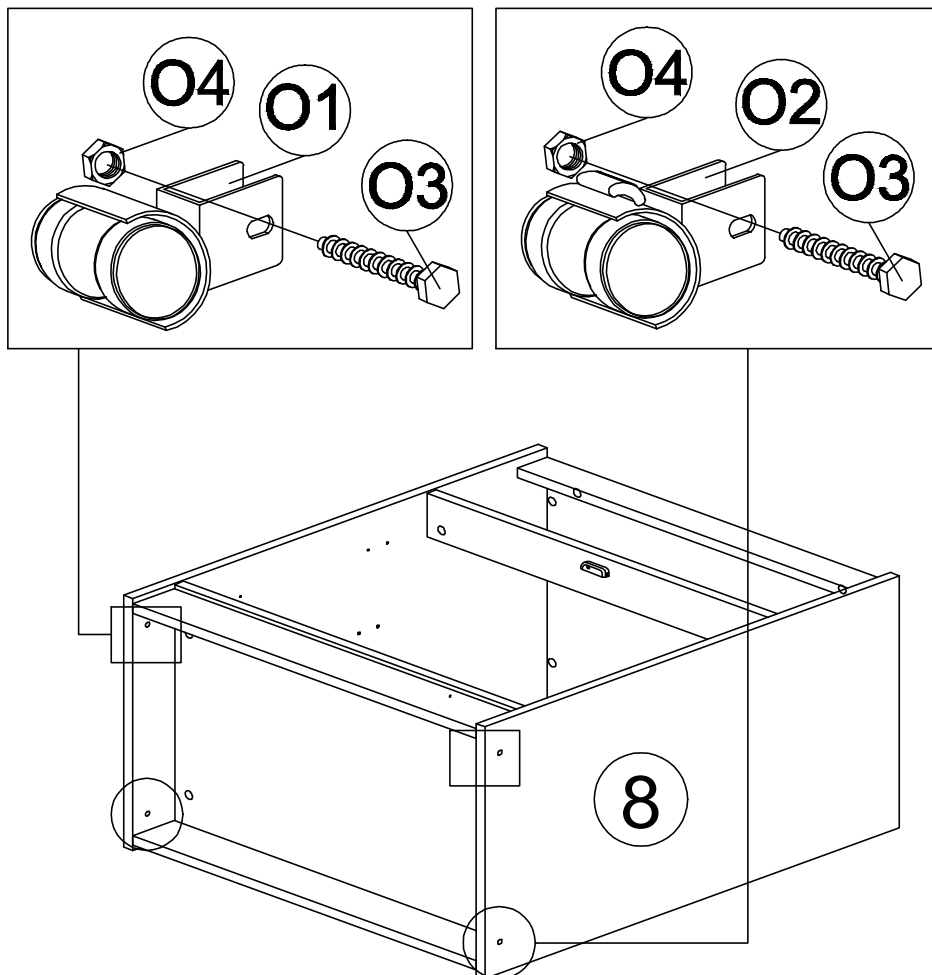

PART 1

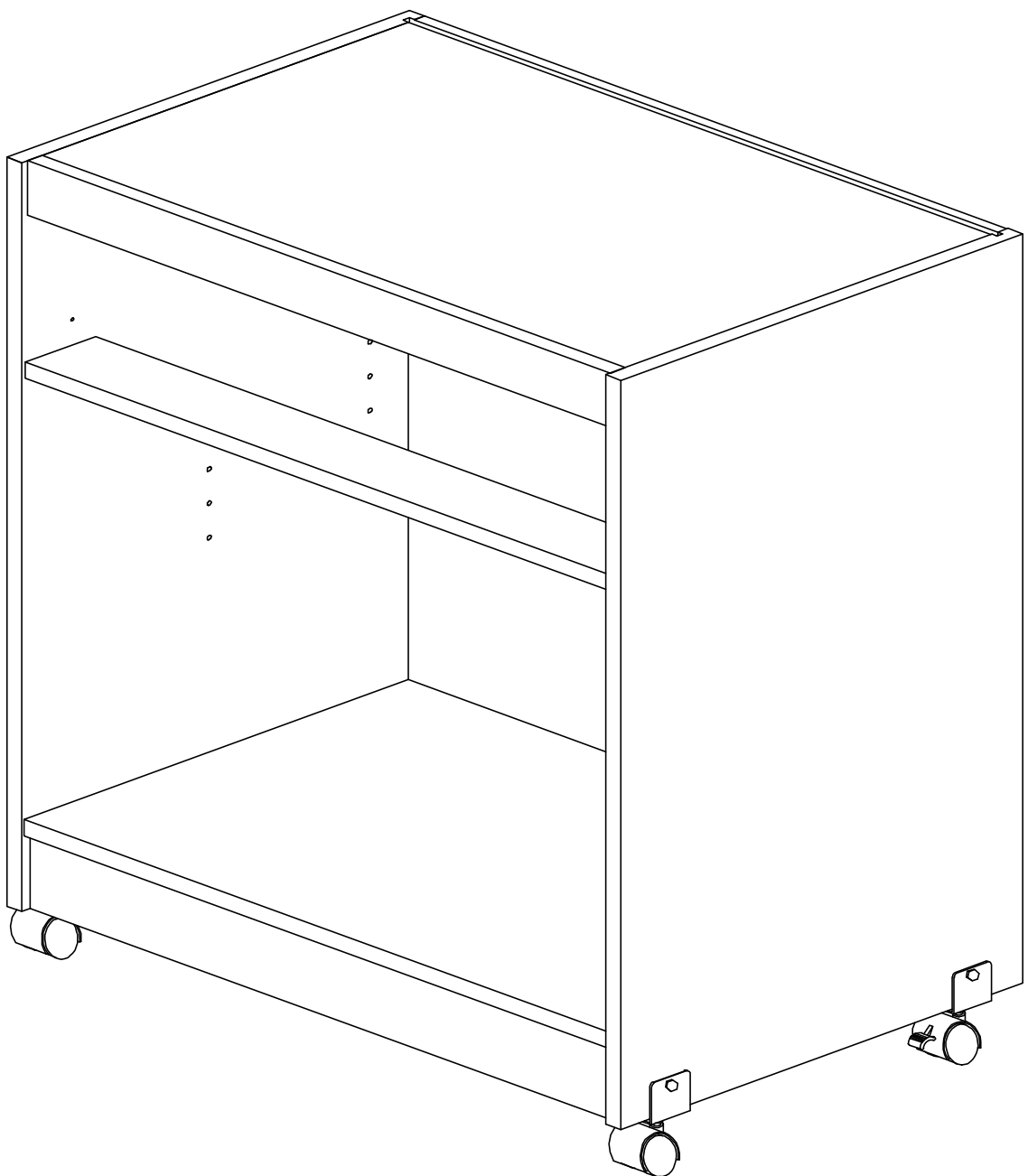

Assembly Instruction Step 7

Fix Panel (11,12) Onto Panel (9) By Inserting Minifix (I1) Into Panel (11,12) 's L-thru Holes And Using Allen Key (F) To Tighten It After That Insert Minifix Cap (I3).

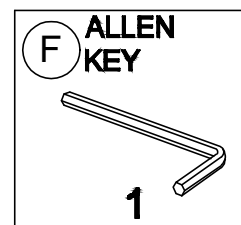
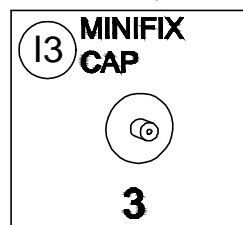
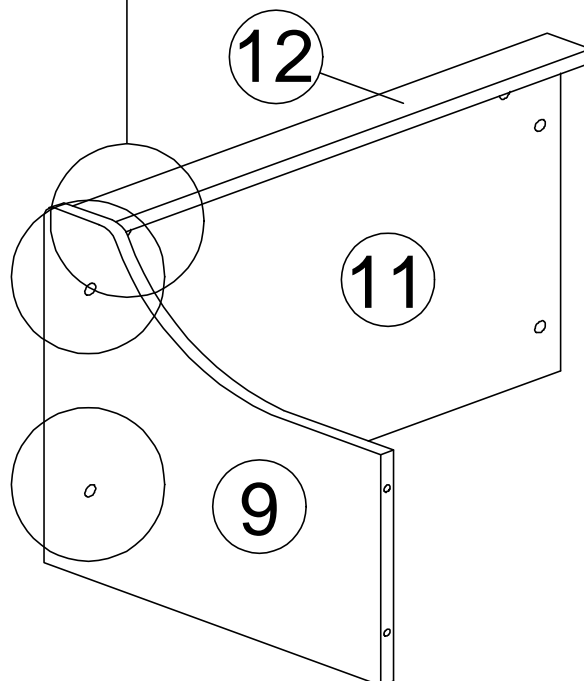
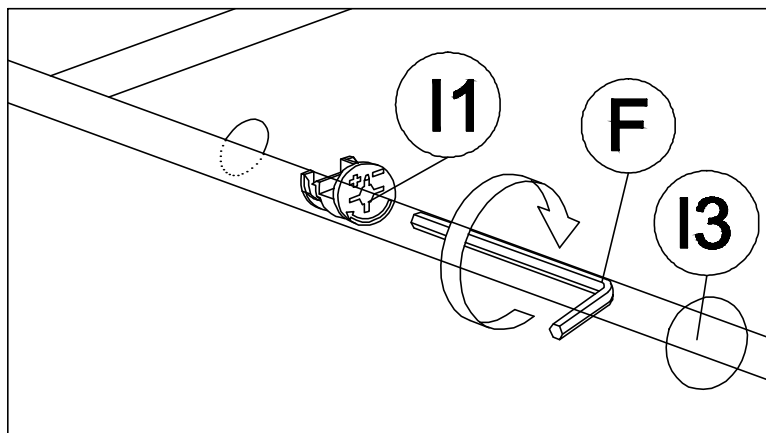

Assembly Instruction Step 8

Fix Panel (11,12) Onto Panel (13) By Inserting Minifix (I1) Into Panel (11,12) 's L-thru Holes And Using Allen Key (F) To Tighten It After That Insert Minifix Cap (I3).

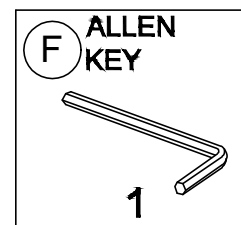
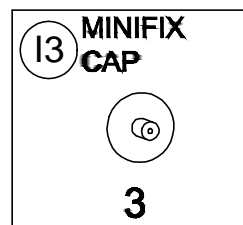
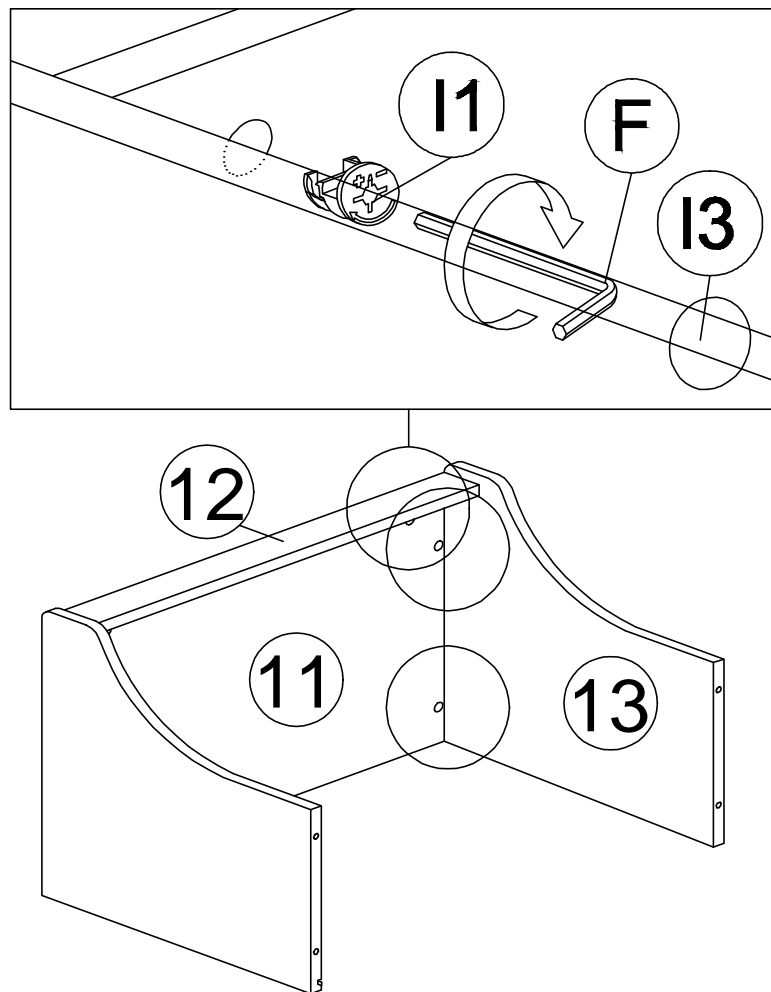

PART 2

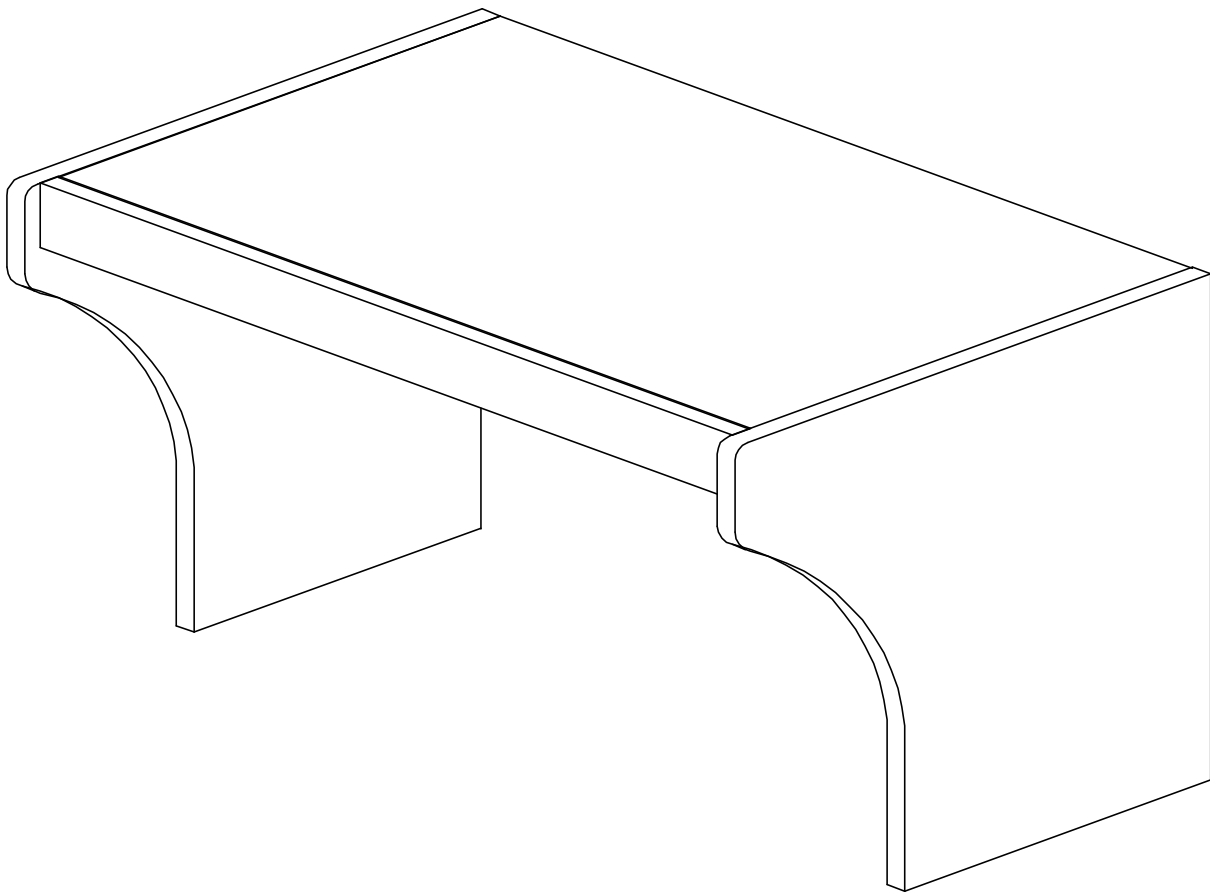

Assembly Instruction Step 9

Insert Dowel (**B**) And Double Head Minifix (**L1**) Into Panel (**9,13**) And Panel (**1,8**) And Minifix (**L2**) Into Panel (**9,13**) And Panel (**1,8**)'s L 'thru Holes And Using Allen Key (**F**) To Tighten It After That Insert Minifix Cap (**L3**).

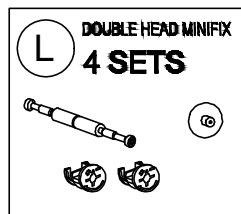
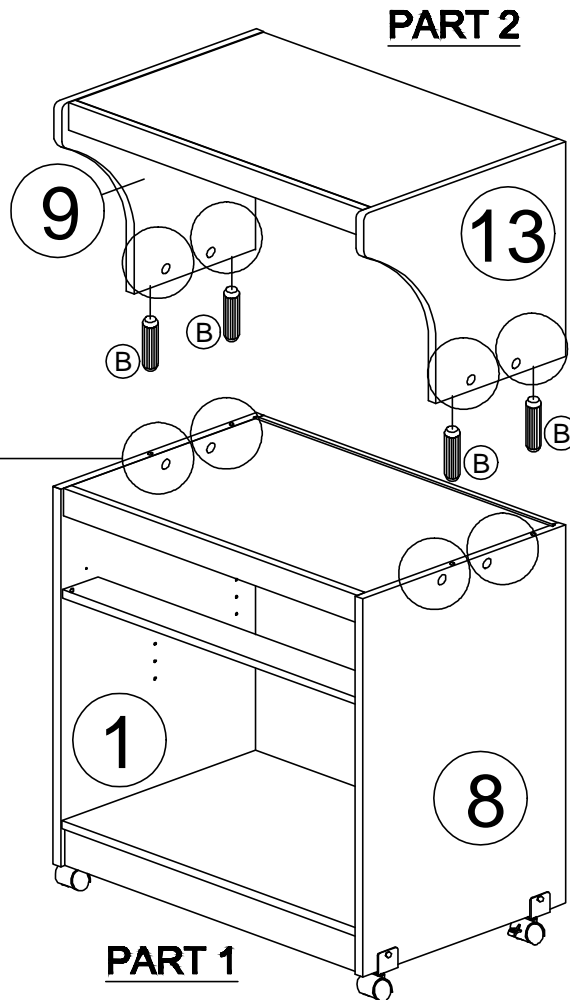
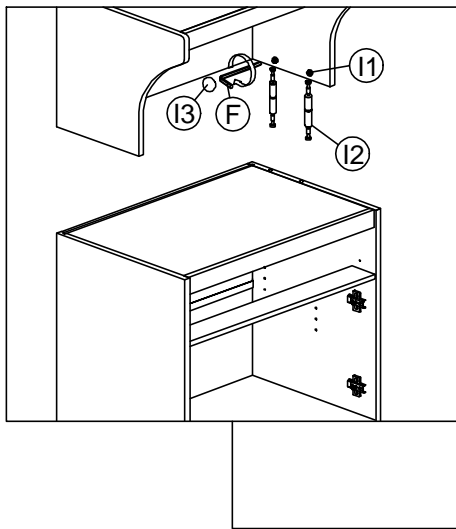

Assembly Instruction Step 10

At Face Down Position, Place Back Panel (5,10) Onto The Back Of Main Unit, And Align It Properly For Nailing. Use Hammer To Nail The Nails One By One On The Line Drawer And At Center Of 4 Side Edges. Gap Between 2 Nails Is About 100mm For All.

