

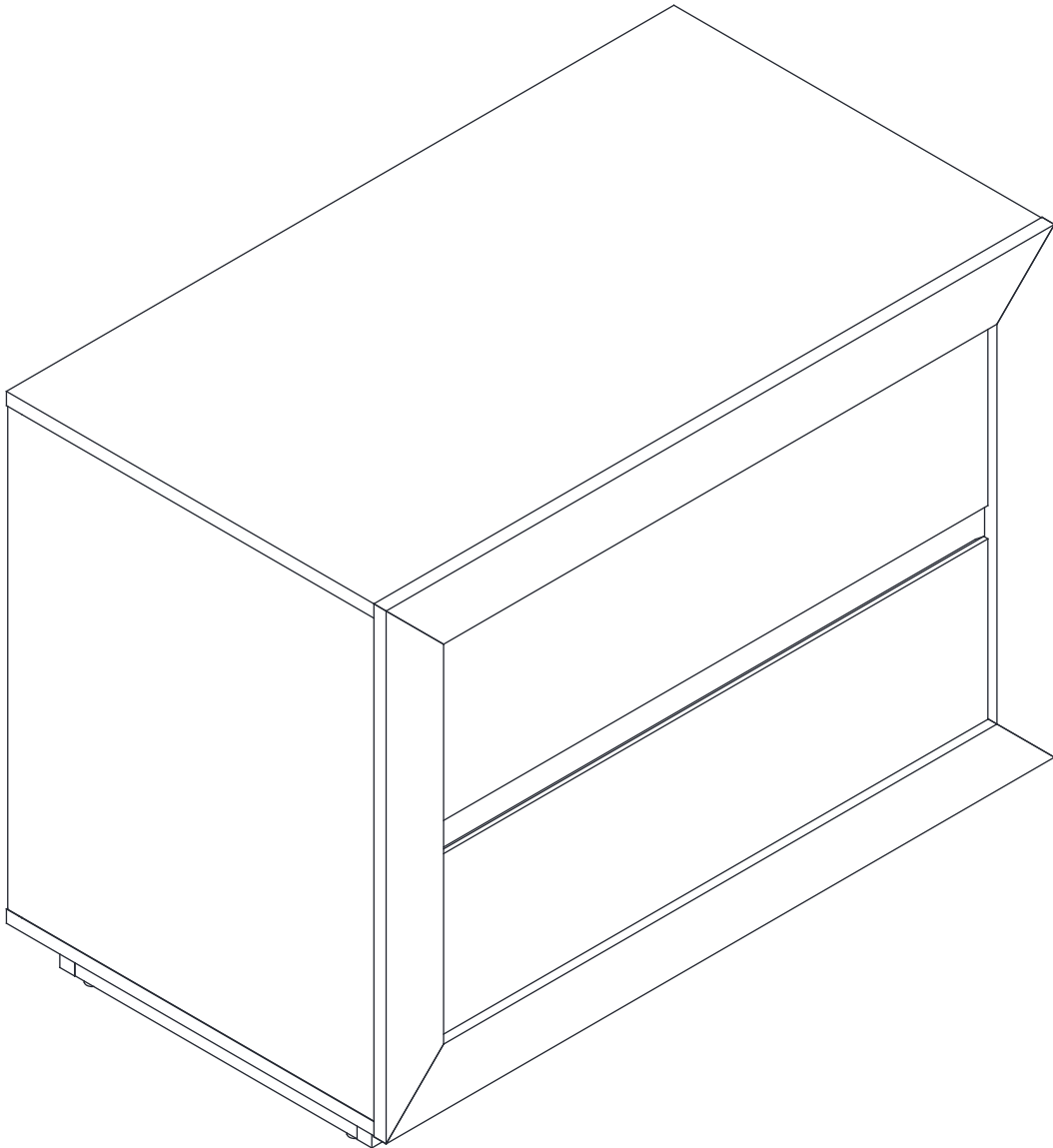

# MANHATTAN COMFORT

---

## NS1876





# STOP!

Before beginning the assembly process, ensure all boxes and parts have been delivered.

## FOR BEST RESULTS:

- Do not throw away packaging materials until assembly is complete.
- Assemble item on a soft surface, such as cardboard or carpet, to protect finish.
- Proper assembly requires two people.

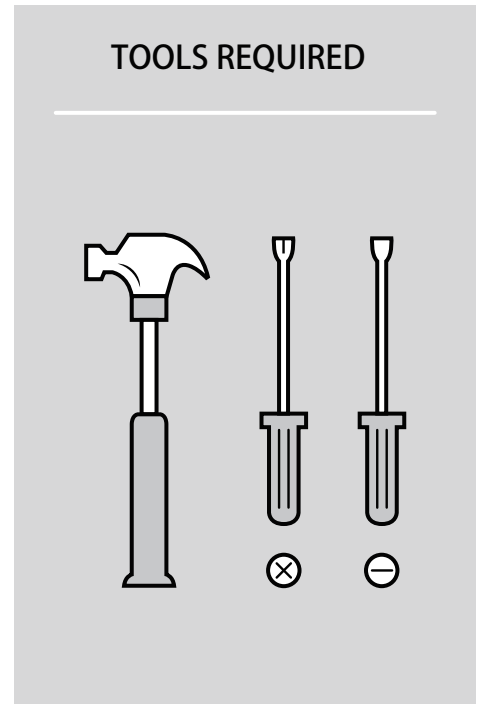
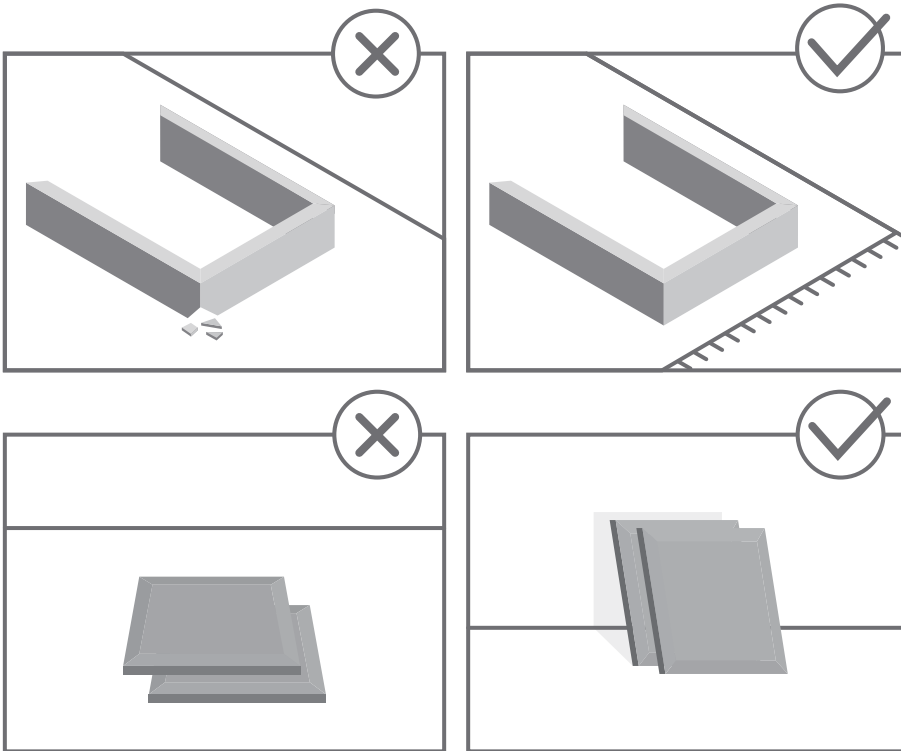

View our assembly video online:  
[WWW.MANHATTANCOMFORT.COM](http://WWW.MANHATTANCOMFORT.COM)



Stuck? Question? We are here to help.  
tel: 908-888-0818  
e-mail: [help@manhattancomfort.com](mailto:help@manhattancomfort.com)

Support Site



# Included in this package:

- A:Top Panel (1)
- B:Bottom Panel (1)
- C:Left Side Panel (1)
- D:Right Side Panel (1)
- E:Back Panel (1)
- F:Deco Frame (1)
- G:Front and Back Plinth (2)
- H:Left and Right Plinth (2)
- J:Top Drawer Front Panel (1)
- K:Drawer Side Panel Left (2)
- L:Drawer Side Panel Right (2)
- M:Drawer Back Panel (2)
- N:Drawer Bottom Panel (2)
- P:Bottom Drawer Front Panel (1)
- Q:Connecting Panel(1)

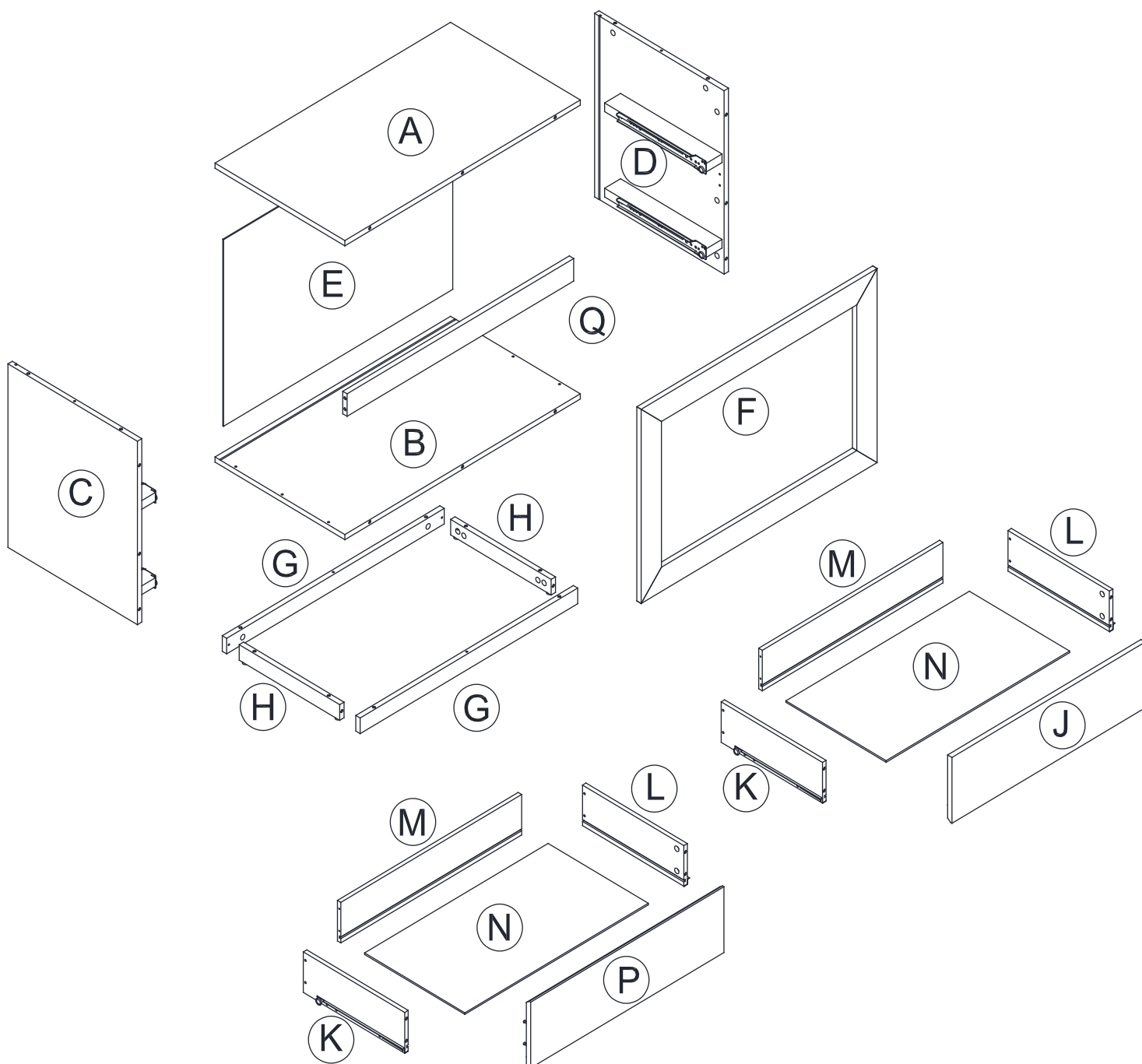

# Hardware Identification

---

① CAM SCREW - 40pcs

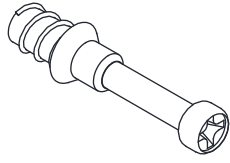

② HIDDEN CAM - 40pcs

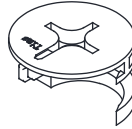

③ WOOD DOWEL - 6pcs

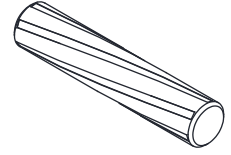

④ APPLIQUE CARD - 7pcs

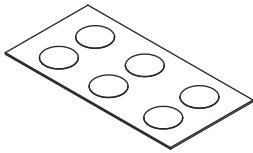

⑤ BACK PANEL CLIPS - 10pcs

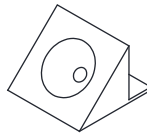

⑥ PAN HEAD SCREW  
M5\*35 - 12pcs

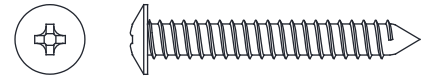

⑦ FLAT HEAD SCREW  
M3\*16 - 10pcs



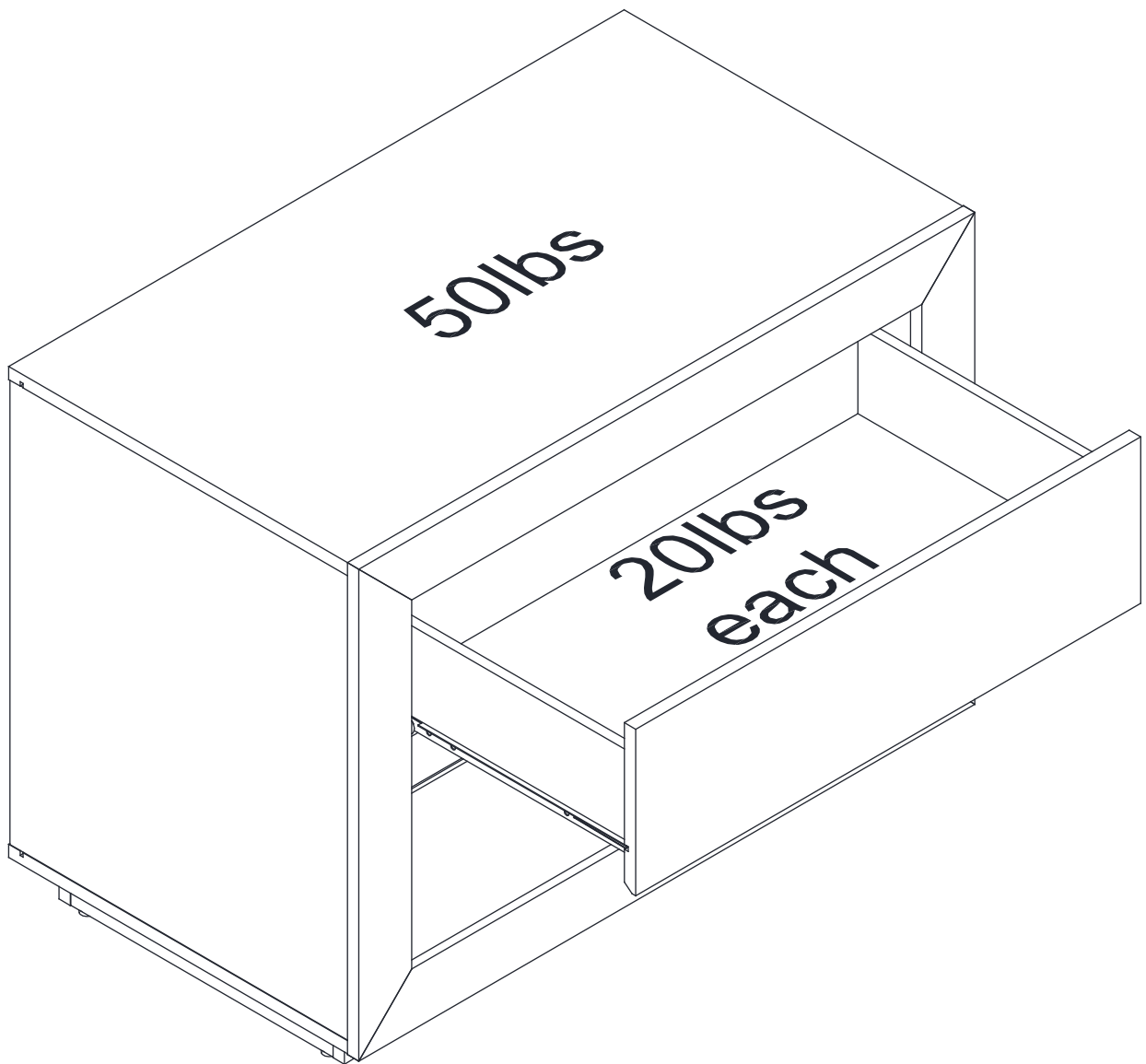

# Step 1

- ◆ Screw 40 Cam Screw (1) into the Top Panel (A), the Bottom Panel (B), Left and Right Side Panel (C,D), the Deco Frame (F), the Front and Back Plinth (G), the Top Drawer Front Panel (J) and the Bottom Drawer Front Panel (P).

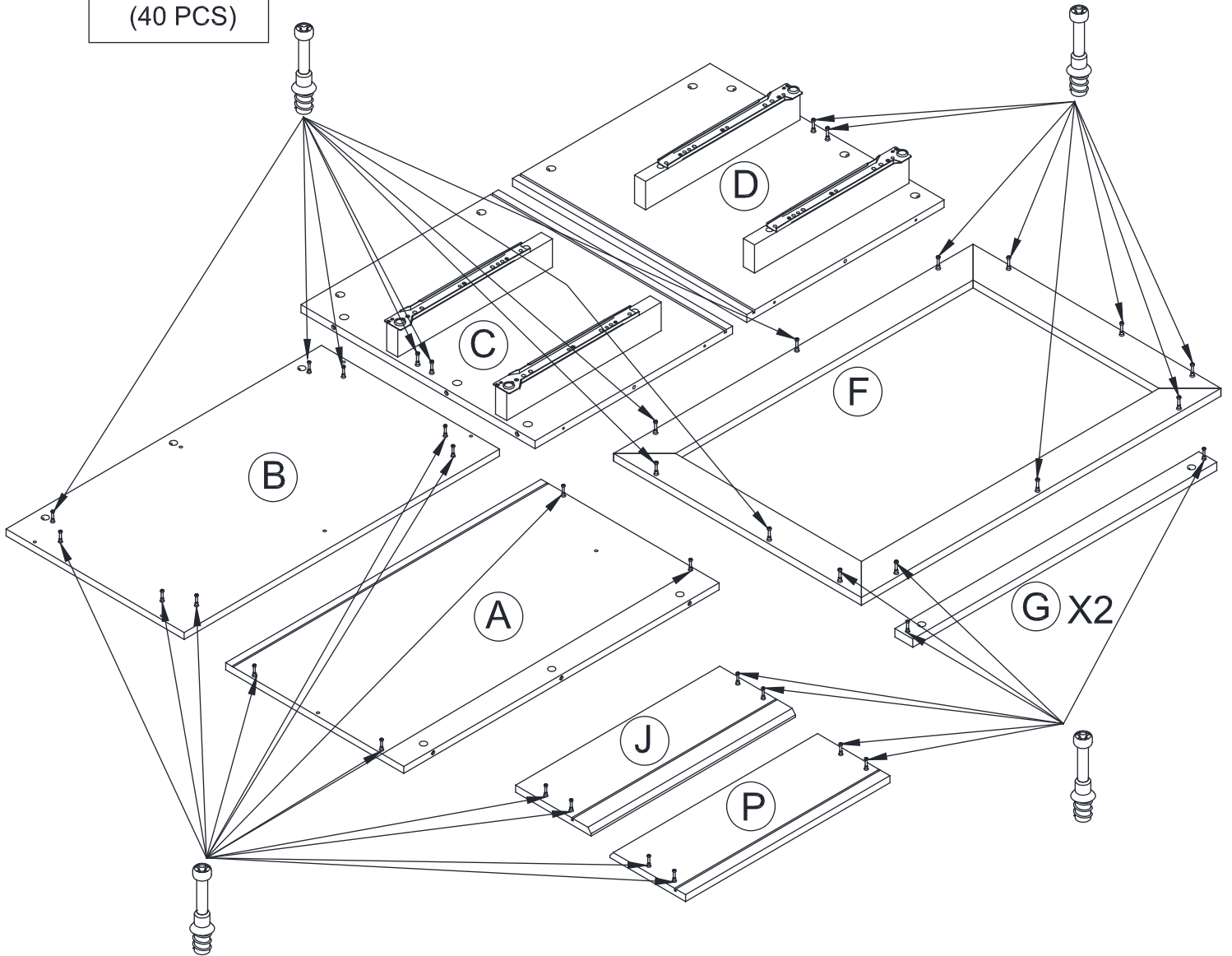
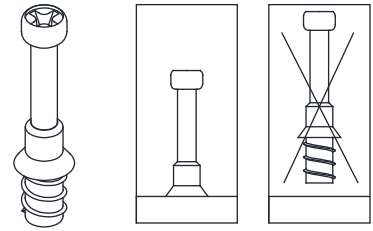
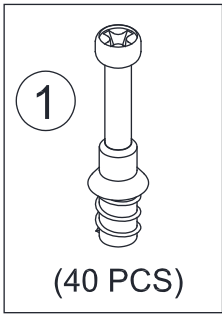

# Step 2

- ◆ Insert 40 Hidden Cam (2) into the Top Panel (A), the Bottom Panel (B), the Left and Right Side Panel (C, D), the Front and Back Plinth (G), Left and Right Plinth (H), the Connecting Panel (Q), the Drawer Side Panel Left and Right (K,L).

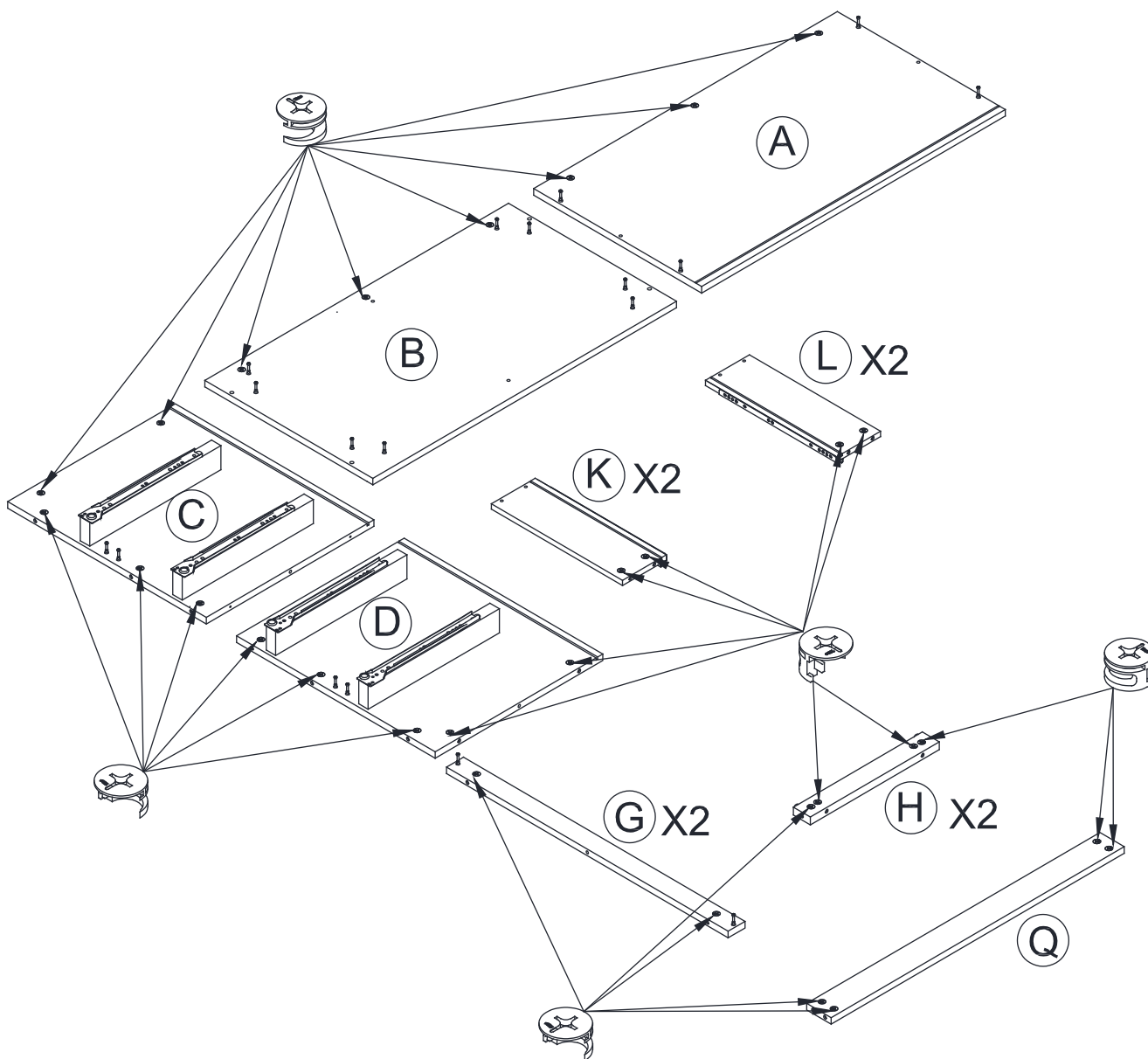
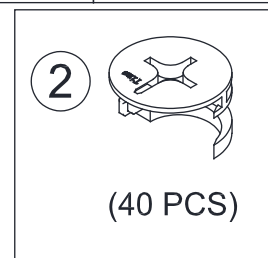
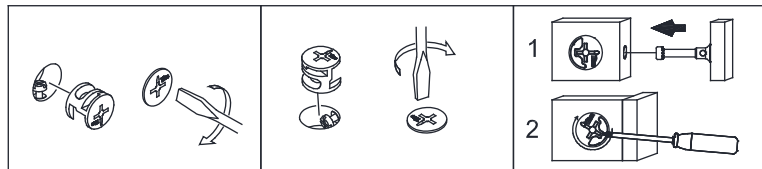

# Step 3

- ◆ Use Wood Dowel (3) and Pan Head Screw (6), secure the Left Side Panel (C) to the Bottom Panel (B).

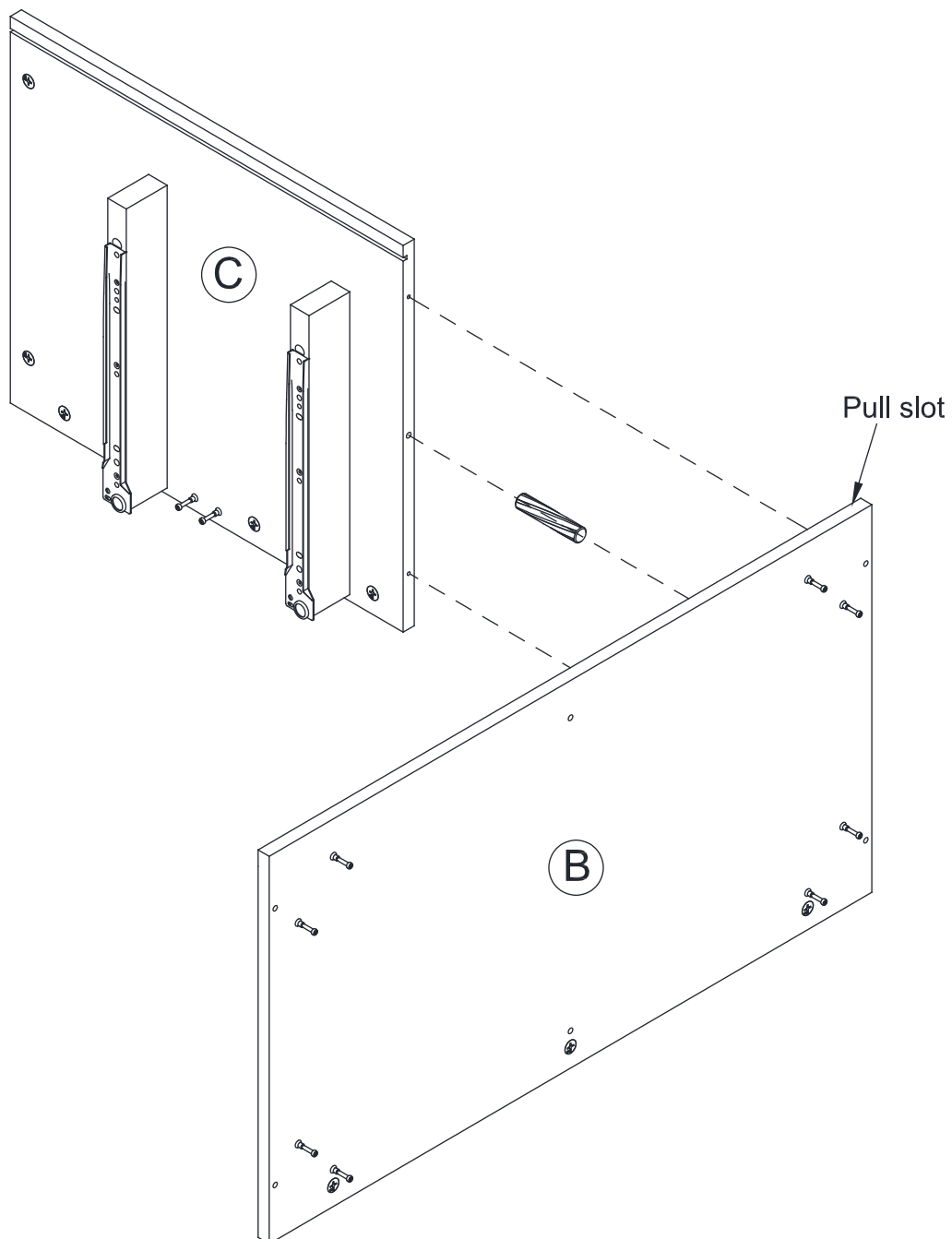
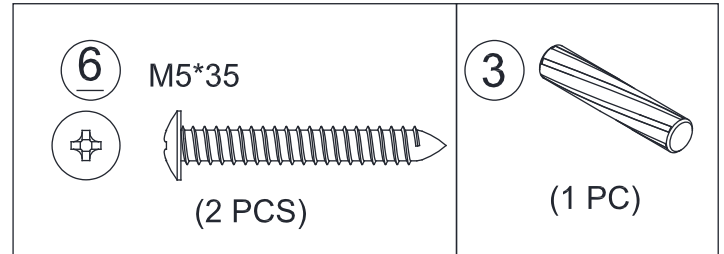

# Step 4

- ◆ Secure the Right Side Panel (D) to the Bottom Panel (B) using Wood Dowel (3) and Pan Head Screws (6). Then use cam locks to fix the Connecting Panel (Q) to the Left and Right Side Panel (C,D).

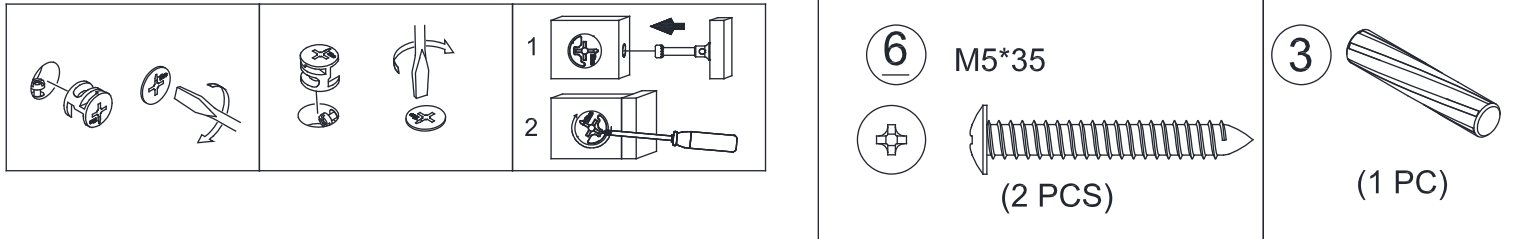

After attaching the connecting panel to the left side panel, do not tighten it fully. Once the right side panel is connected with the hidden cam, tighten all fittings together.

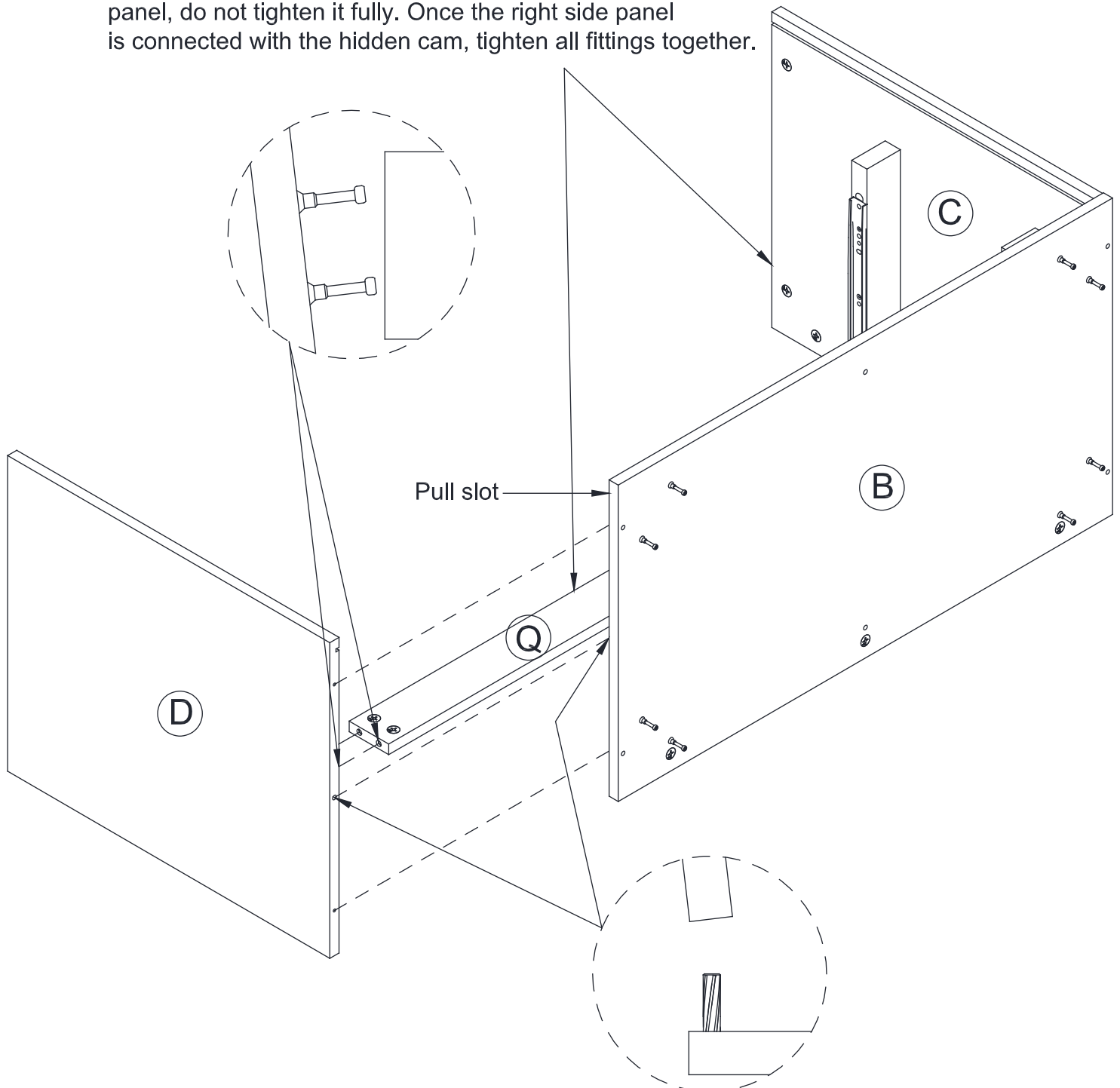

# Step 5

- ◆ Using Hidden Cam (2), secure the Front and Back Plinth (G) to the Left and Right Plinth (H).

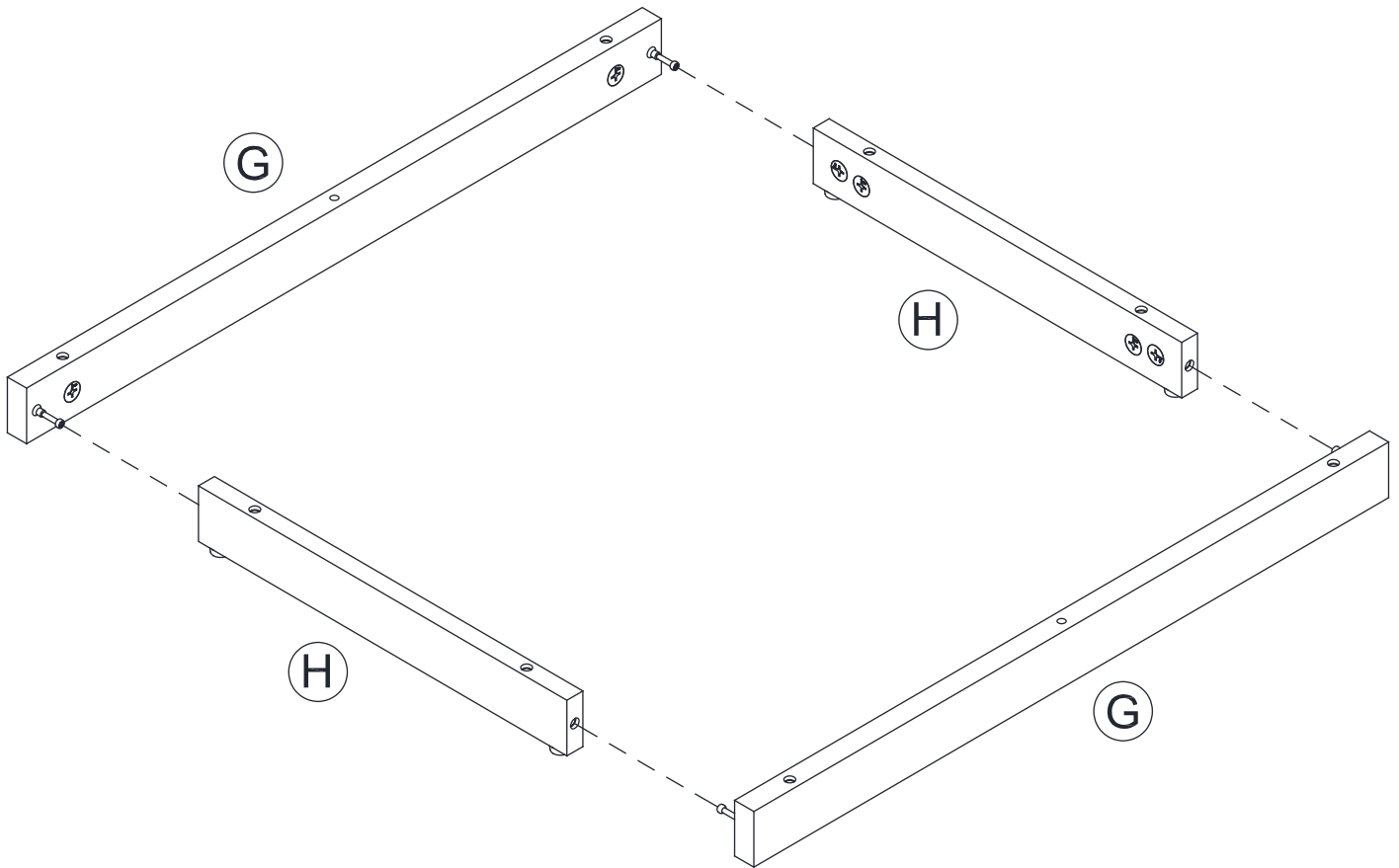
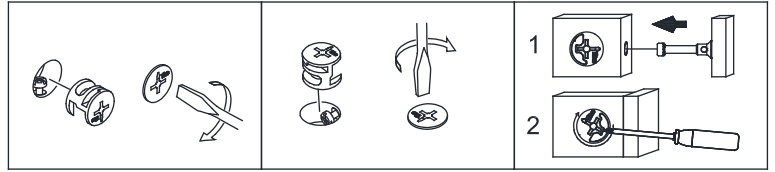

# Step 6

- ◆ Using Wood Dowel (3) and Hidden Cam (2), secure the Front and Back Plinth (G) and the Left and Right Plinth (H) to the Bottom Panel (B).

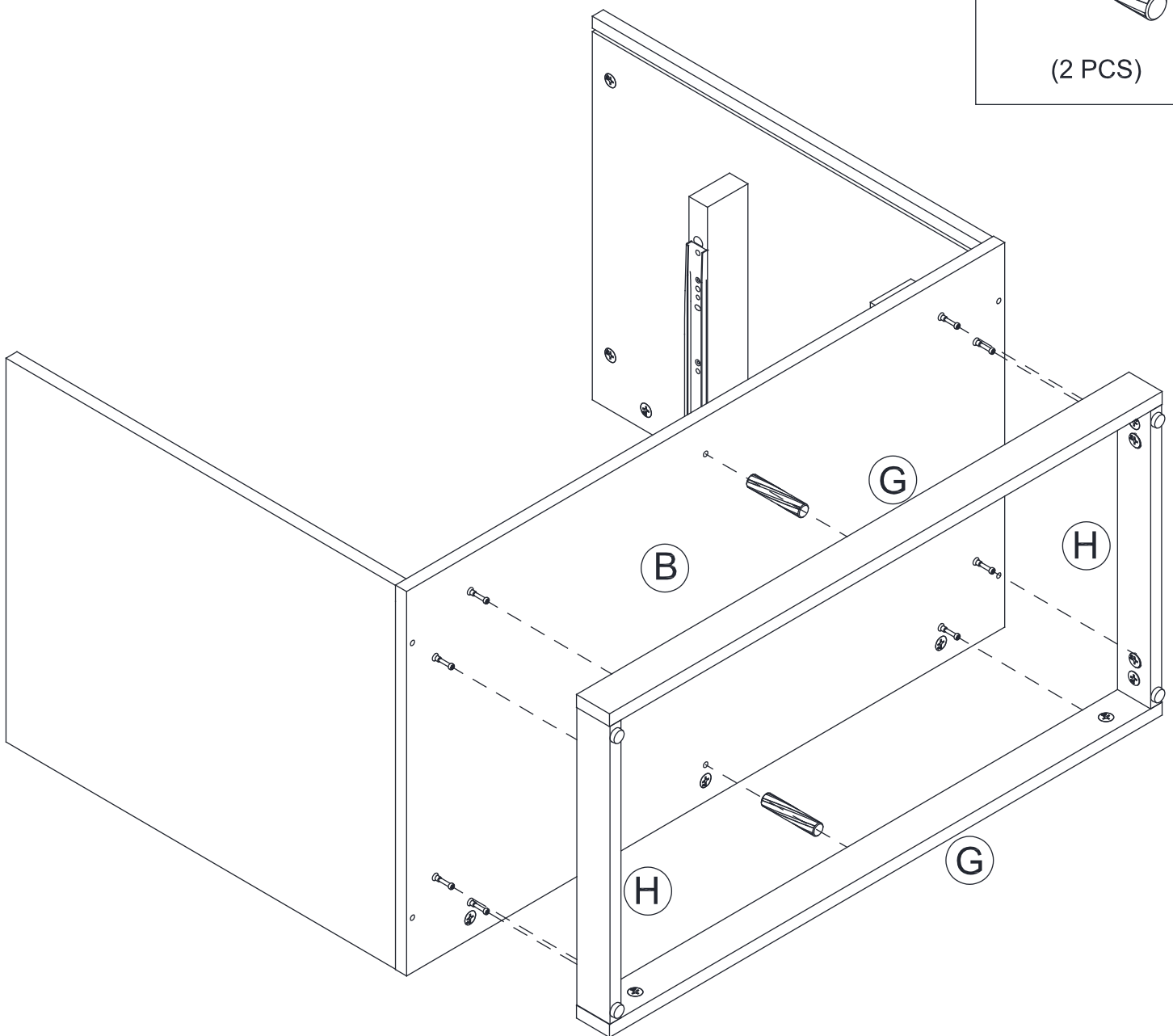
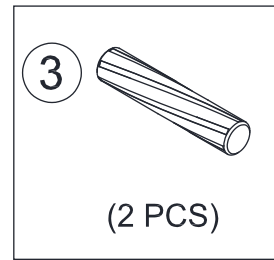
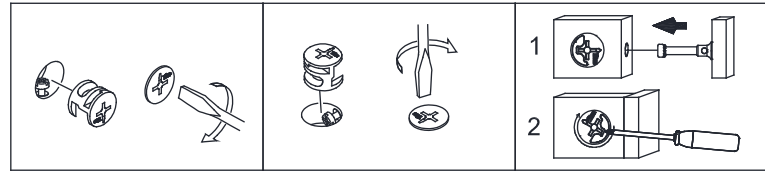

# Step 7

- ◆ Slide the Back Panel (E) into the grooves of the Left and Right Side Panel (C,D) and the Bottom Panel (B).

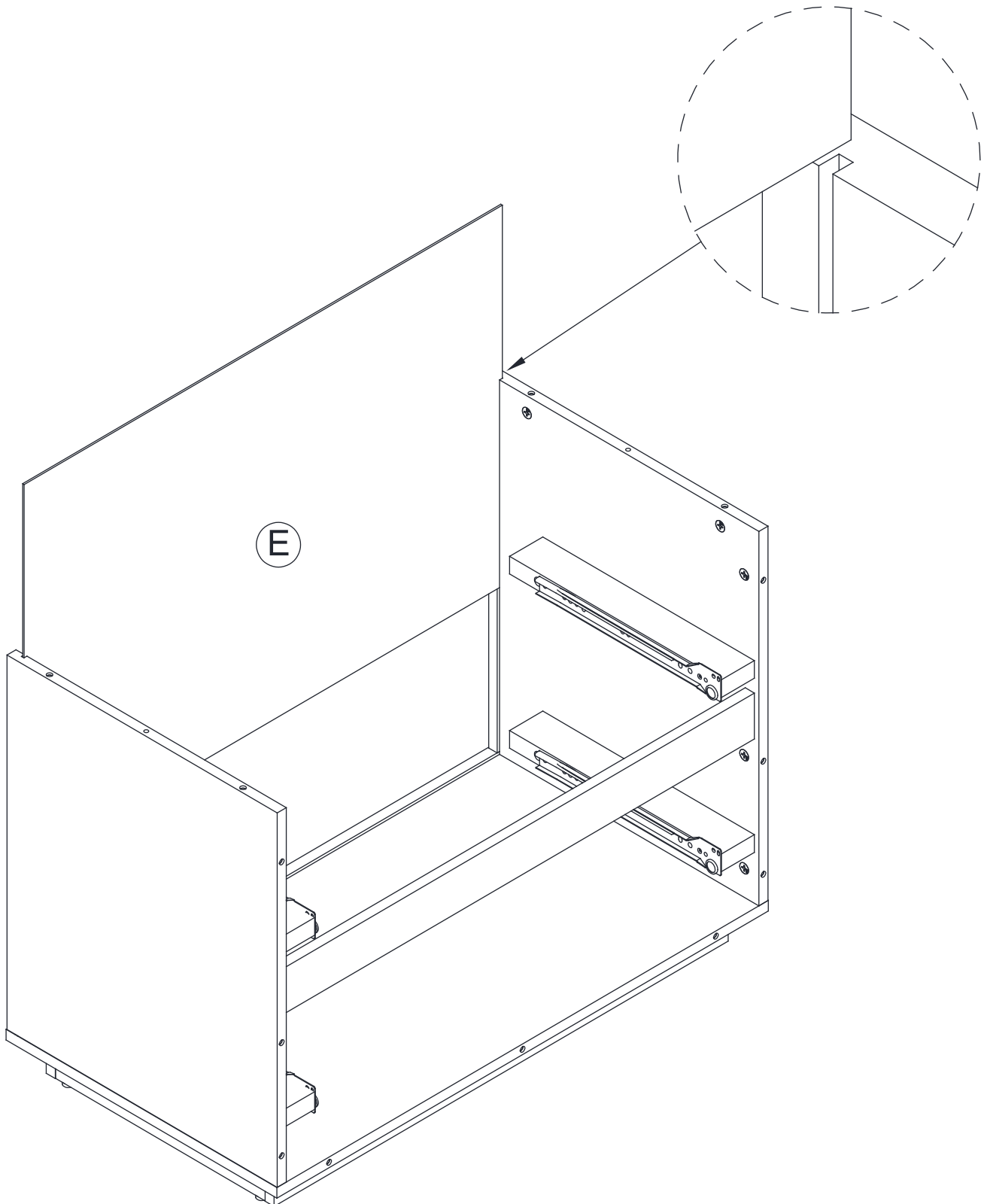

# Step 8

- ◆ Using Wood Dowel (3) and Hidden Cam (2), secure the Top Panel (A) to the Left and Right Side Panel (C,D).

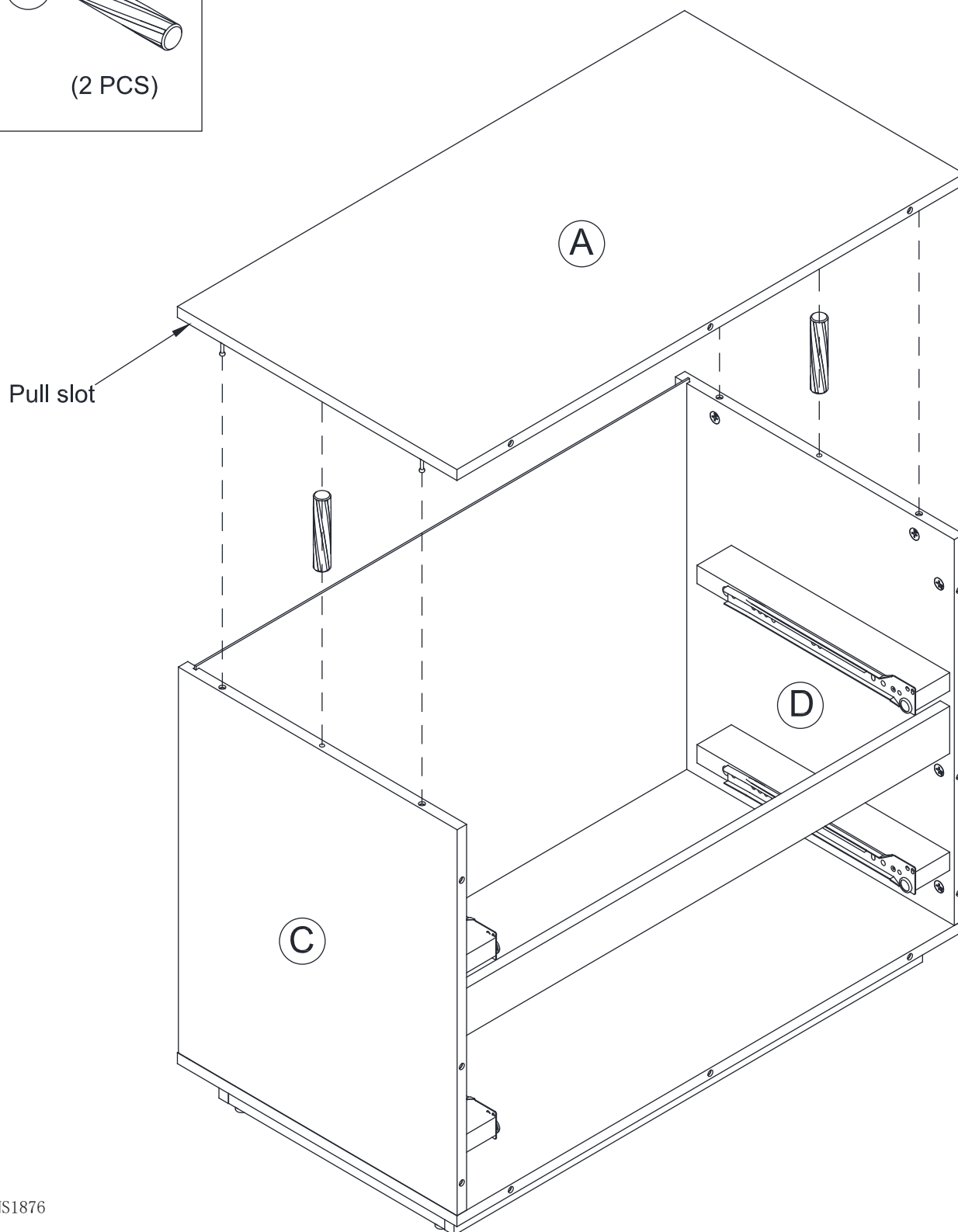
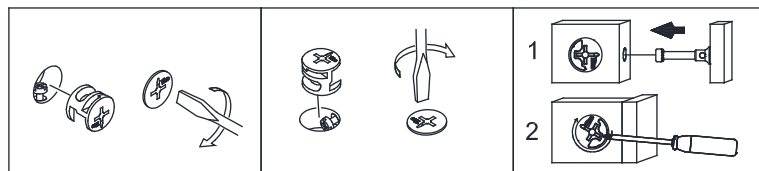
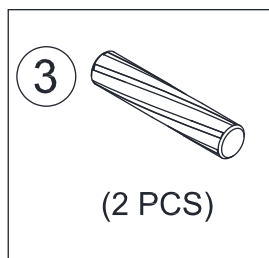

# Step 9

- ◆ Using Hidden Cam (2), secure the Deco Frame (F) to Top Panel (A), the Bottom Panel (B) and the Left and Right Side Panel (C,D).

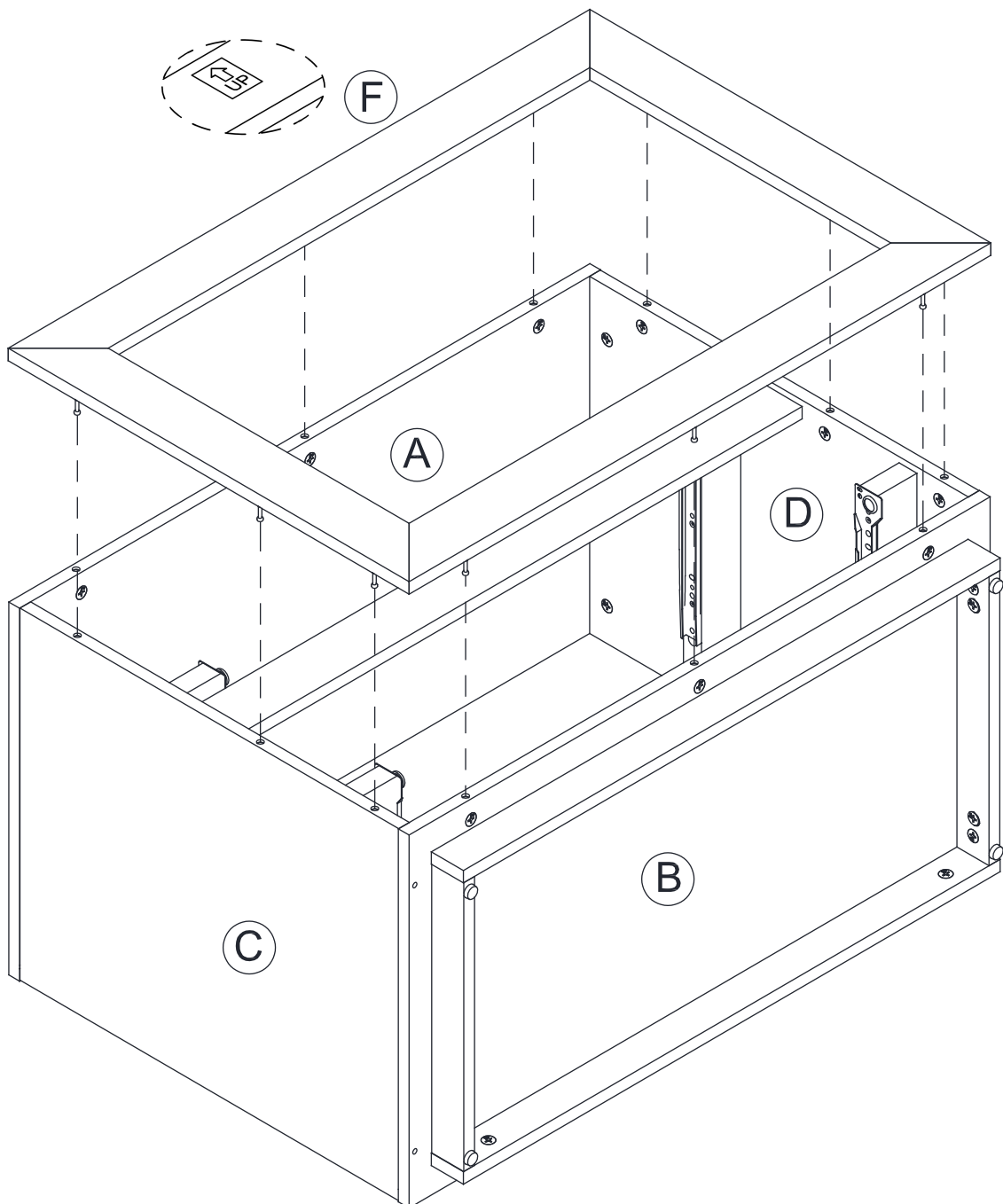
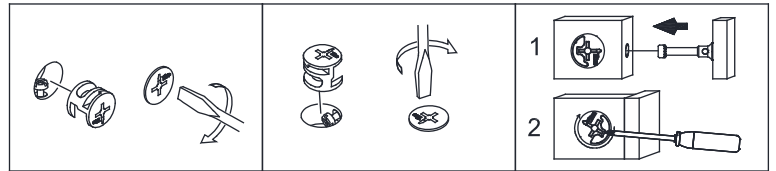

# Step 10

- ◆ Fasten the Drawer Side Panel Left (K) and Drawer Side Panel Right (L) to the Drawer Back Panel (M) using Pan Head Screws (6).

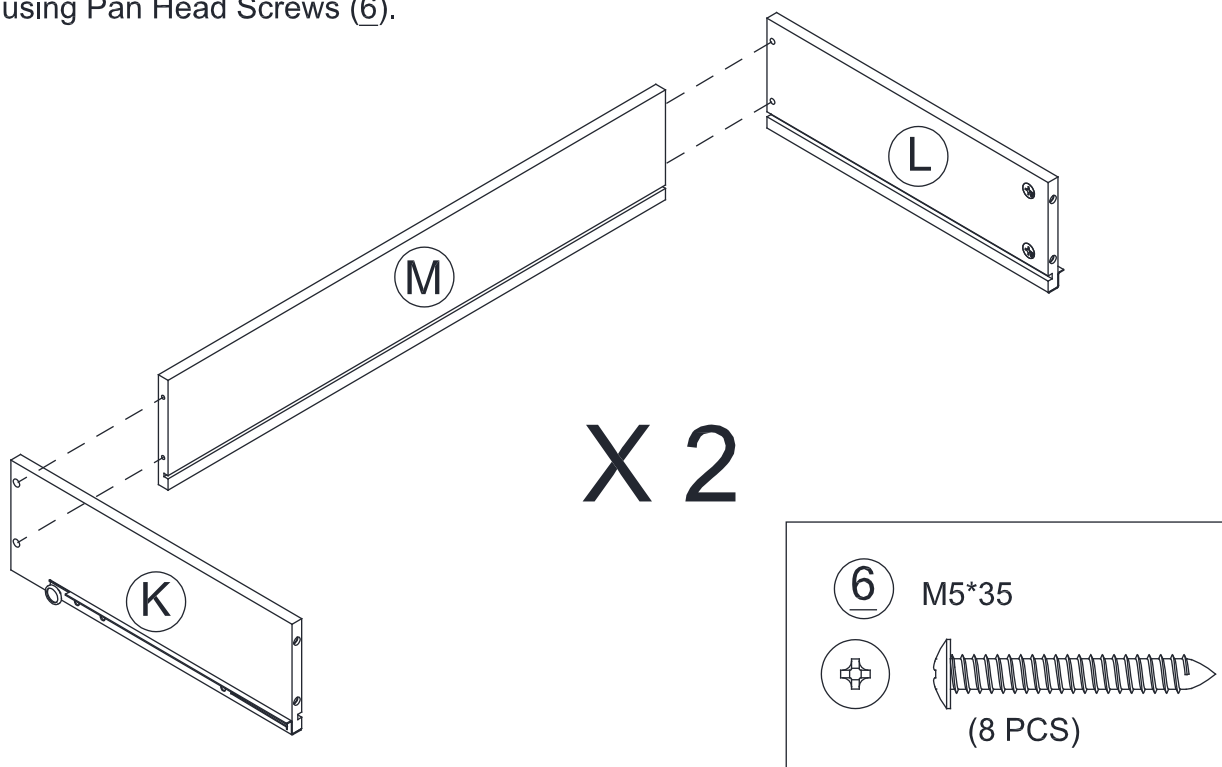

- ◆ Slide the Drawer Bottom Panel (N) into the grooves of the Drawer Side Panel Left and Right (K, L) and the Drawer Back Panel (M).

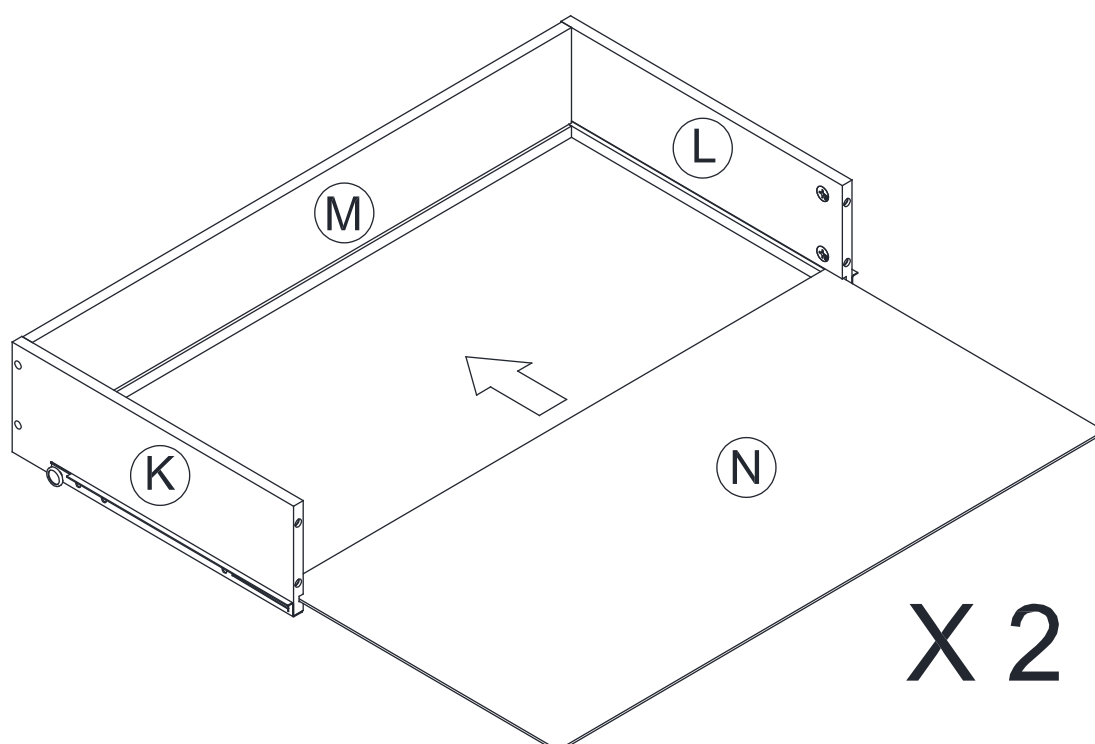

# Step 11

◆ Fasten the Bottom Drawer Front Panel (P) to the Drawer Side Panel Left and Right (K, L) using Hidden Cam (2).

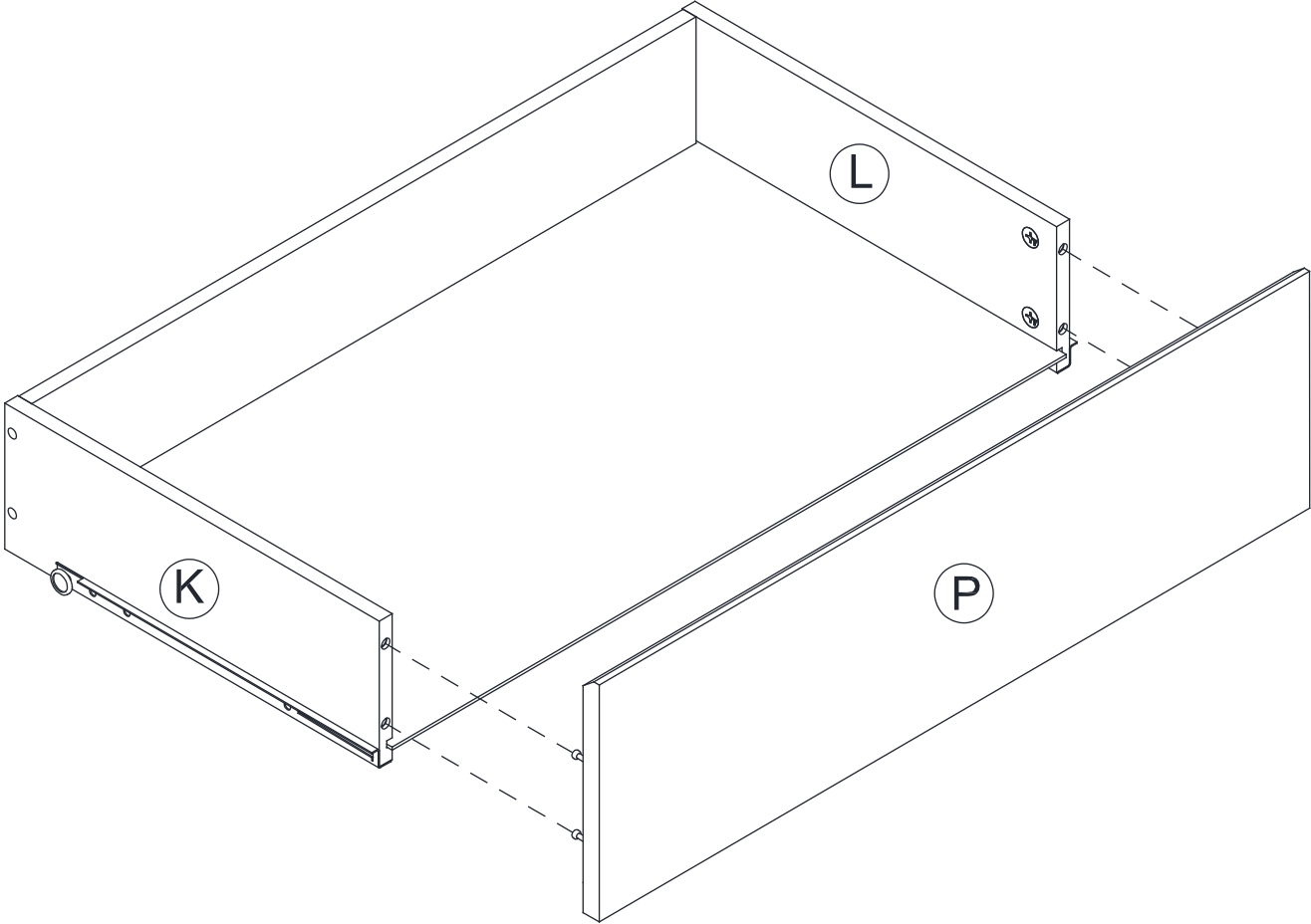
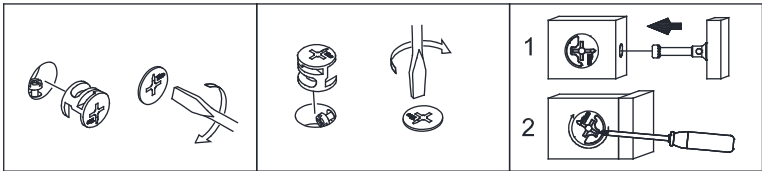

# Step 12

- ◆ Fasten the Top Drawer Front Panel (J) to the Drawer Side Panel Left and Right (K, L) using Hidden Cam (2).

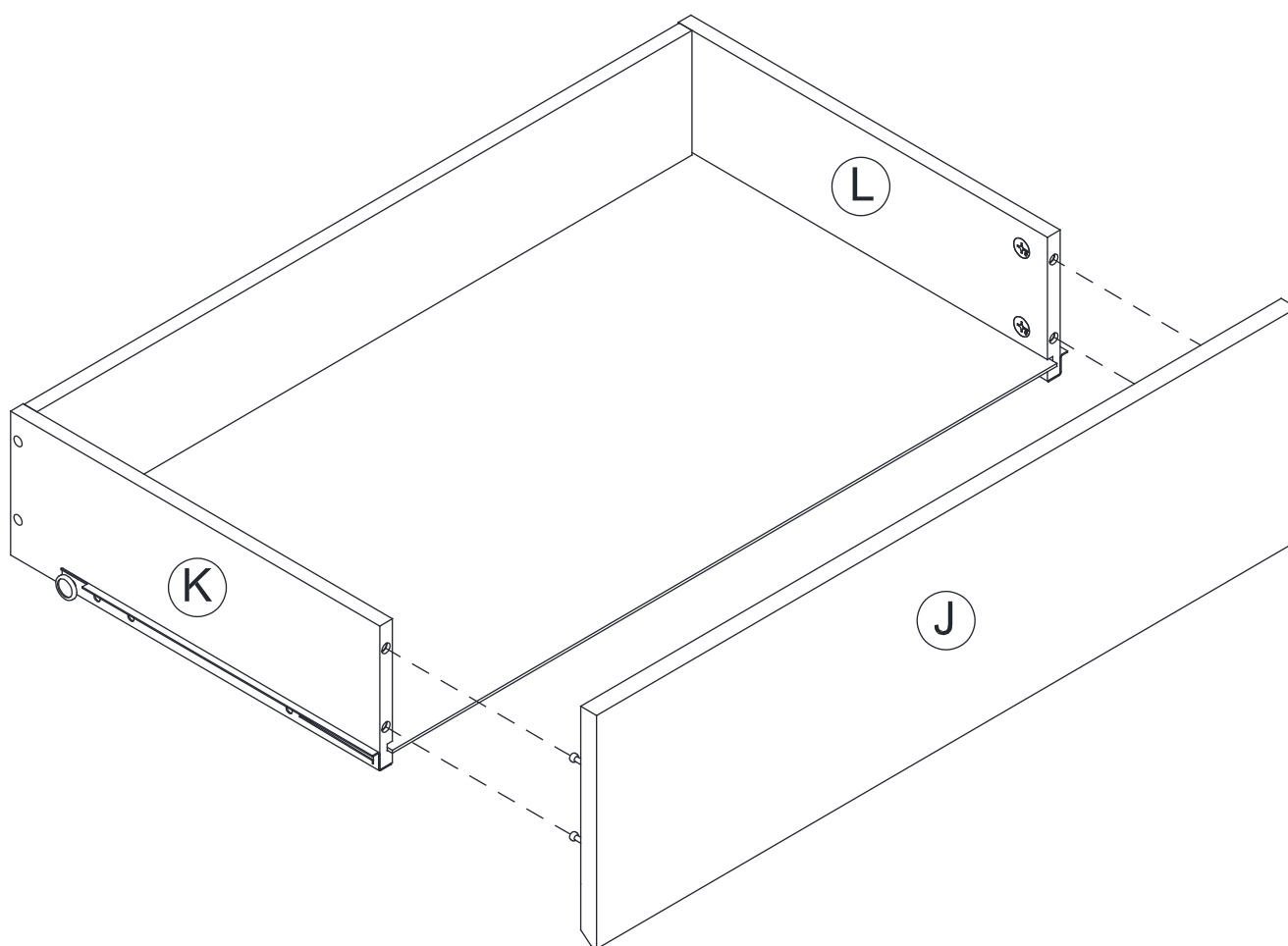
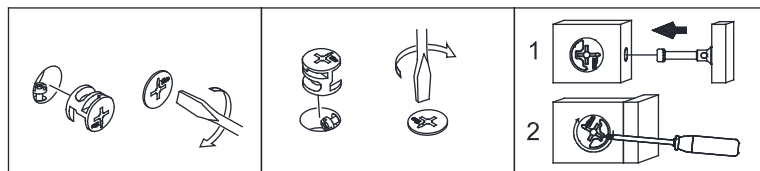

# Step 13

- ◆ Insert the drawers into the cabinet.

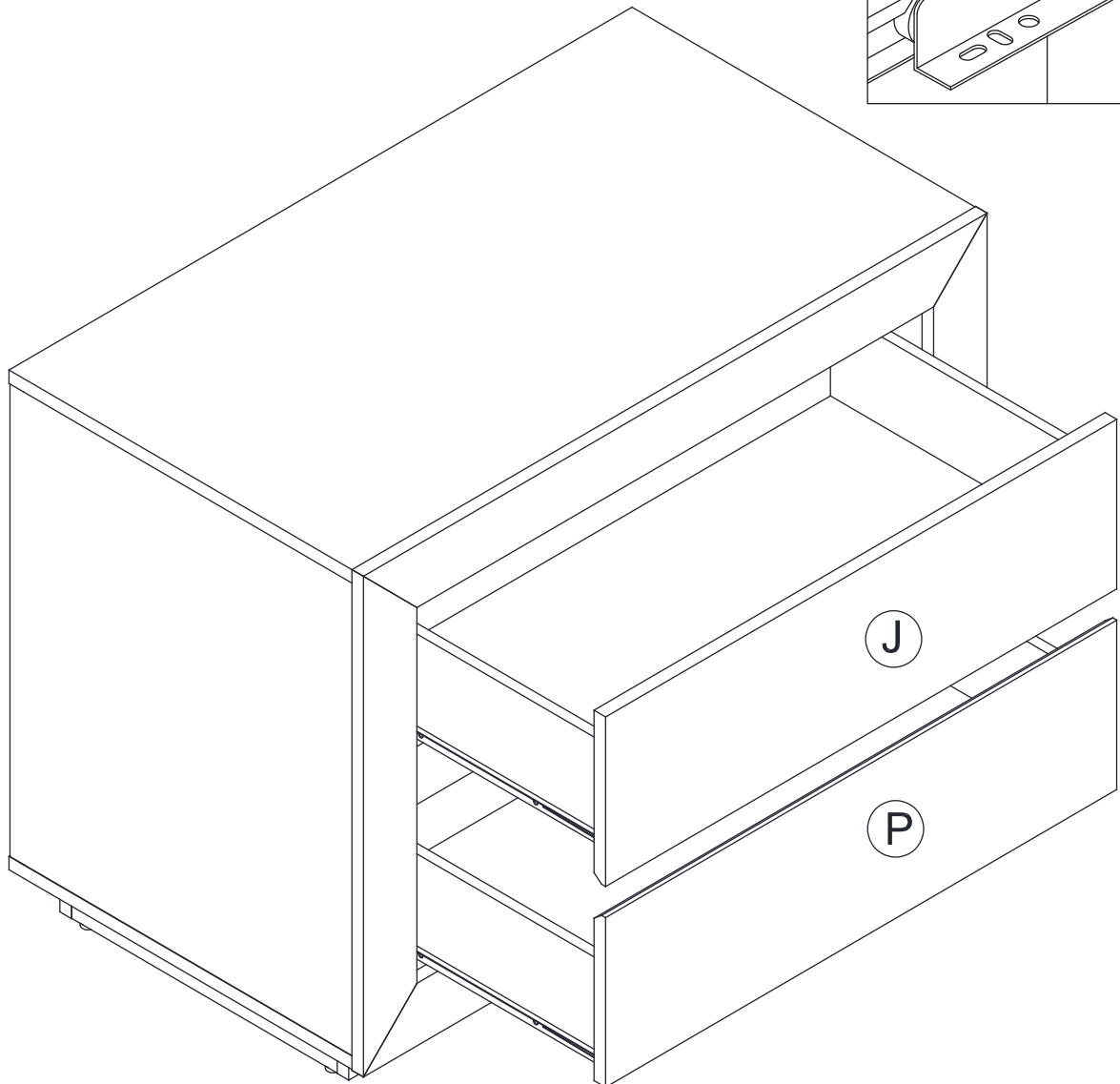
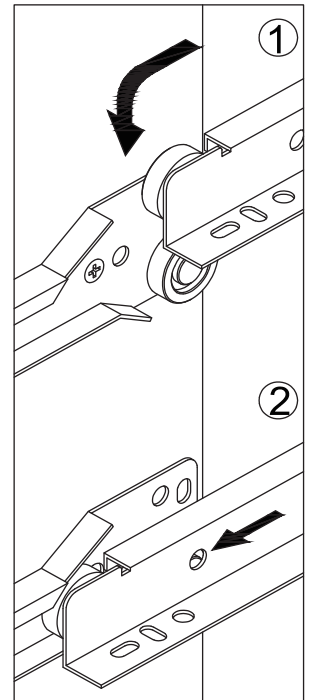

# Step 14

- ◆ Insert the Back Panel Clips (5) into the gaps between the Top Panel (A), the Bottom panel (B), and the Left and Right Side Panel (C, D) of the Back Panel (E), then secure them with Flat Head Screws (7).

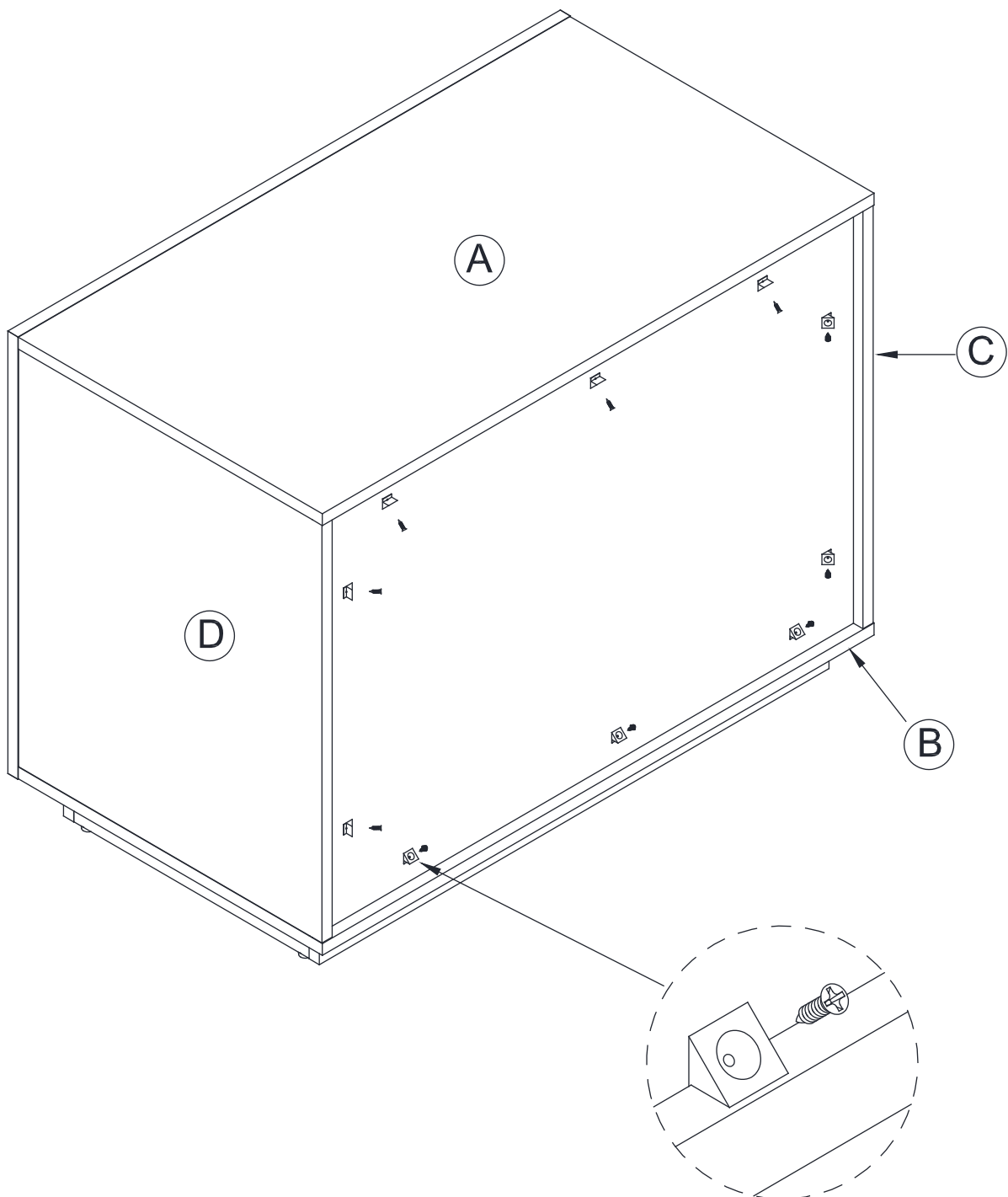
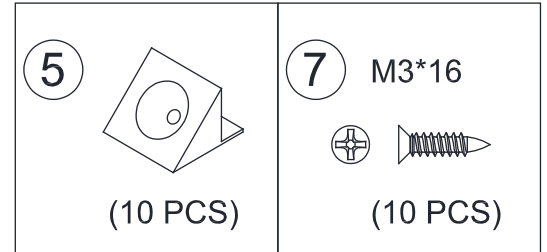

# Step 15

- ◆ Peel off the Applique Card (4) and apply them to each visible Hidden Cam (2).

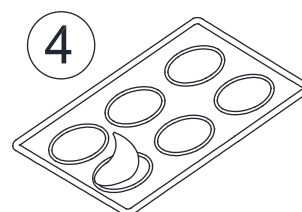
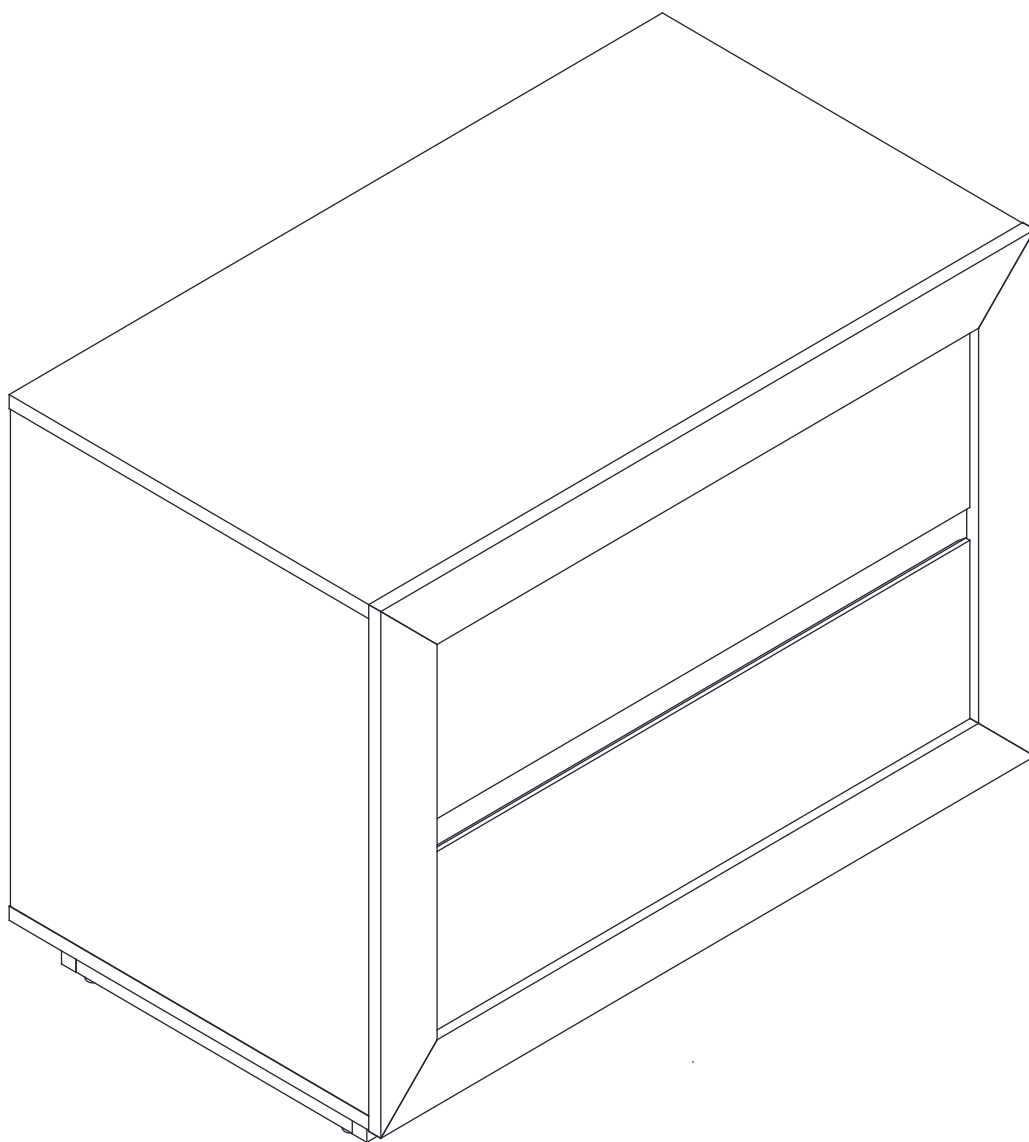



# MANHATTAN COMFORT

---

## **WARRANTY POLICY**

All Manhattan Comfort furniture products are warranted, to the original purchaser at the time of purchase and for a period of 30 days thereafter.

Our warranty is limited to new products purchased in factory sealed cartons. This warranty is valid in the United States of America and Canada.

In order to provide you with timely assistance, please thoroughly inspect your furniture for missing or defective parts immediately after opening the carton.

Manhattan Comfort offers a 30-day parts replacement warranty on all items.

Our furniture products are not intended for outdoor use.

### THE WARRANTY DOES NOT COVER:

- Defects/damages by improper assembly or disassembly.
- Defects/damages caused by shipping. Claims for damage during transit should be placed immediately to the transportation company.
- Defects/damages caused by inappropriate use of the furniture.



319 Ridge Rd. Dayton, NJ 08810

908-888-0818