

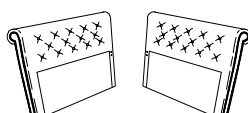

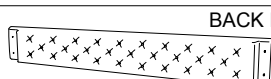





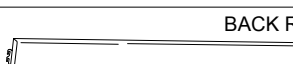
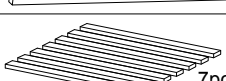

ASSEMBLY INSTRUCTION

MODEL : Day Bed - HB,FB+SR

NO	PART LIST	QTY
1	 HB&FB	2pcs
2	 BACK REST	1pc
3	 FRONT RAIL	1pc
4	 BACK RAIL	1pc
5	 SLAT 7pcs	2pcs
6	 LEG	4pcs
NO	HARDWARE LIST	QTY
A	 SCREW M4 x 32mm	8pcs
B	 JCBB SCREW M8 x 20mm	8pcs
C	 JCBC SCREW M6 x 50mm	8pcs
D	 SPRING WASHER 1/4" x Ø12mm	4pcs
E	 FLAT WASHER 1/4" x Ø19mm	4pcs
F	 L - KEY M5 x 65mm	1pc
G	 L - KEY M4 x 65mm	1pc

STEP 1 Begin assembly by attaching each Leg (6) to the bottom of the HB&FB (1) securing with 2 Allen Bolt (C) per panel.

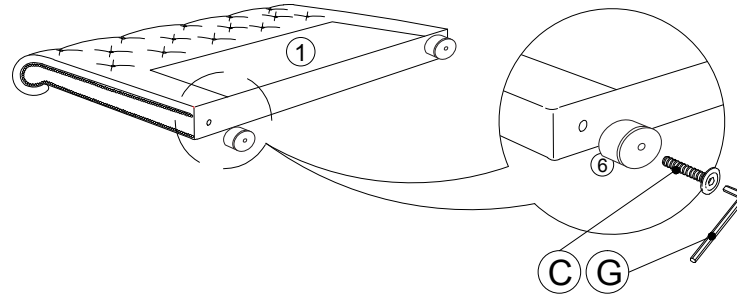

STEP 2 Attach the Front Rail (3) and Back Rail (4) to the HB&FB (1) aligning holes and securing with 2 Allen Bolts (B) per each end. (DO NOT FULLY TIGHTEN BOLTS FOR THIS STEP)

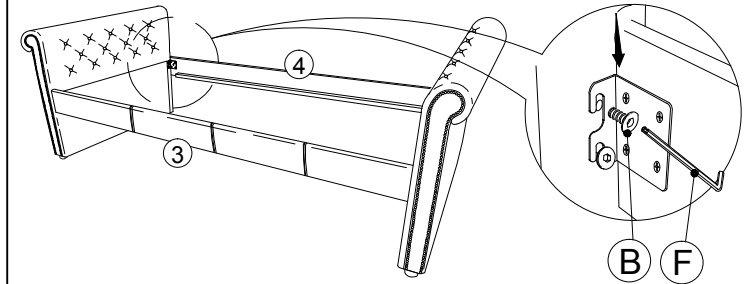

STEP 3 Attach the Back Rest (2) to the back of each HB&FB (1) by aligning the hole and securing with 2 Allen Bolt (C), 2 Spring Washer (D), 2 Flat Washer (E) from the back side per each end. (DO NOT FULLY TIGHTEN BOLTS FOR THIS STEP)

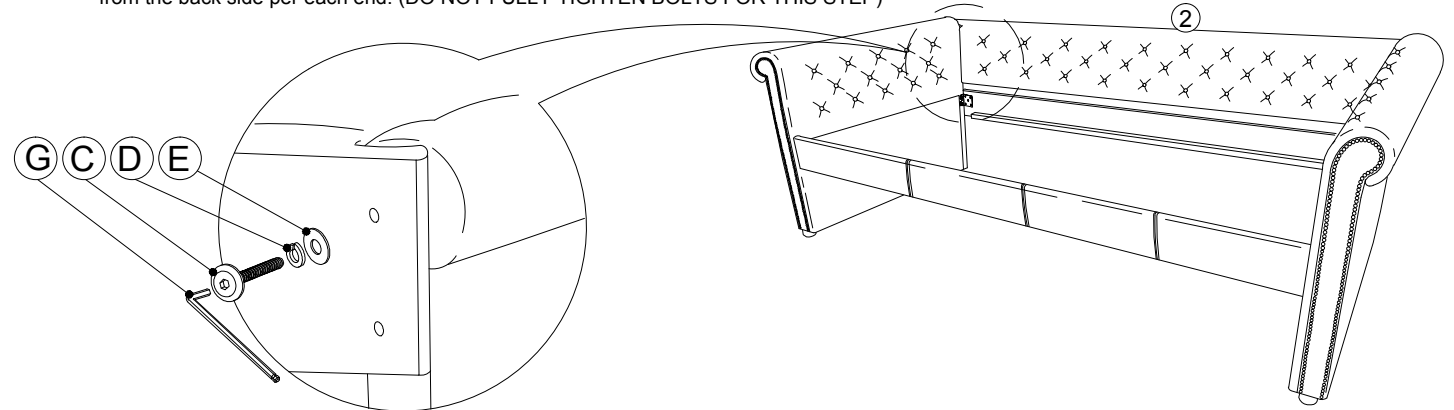

STEP 4 Tighten all bolts from STEP 2 using the Allen Wrench (F) that has been provided. Now only tighten bolts for STEP 3 using Allen Wrench (G). Attach Slat (5) to Front Rail (3) and Back Rail (4) by unrolling and securing with 4 Wood Screws (A) 2 per each side. Tighten all screws using phillips head screwdriver (not included)

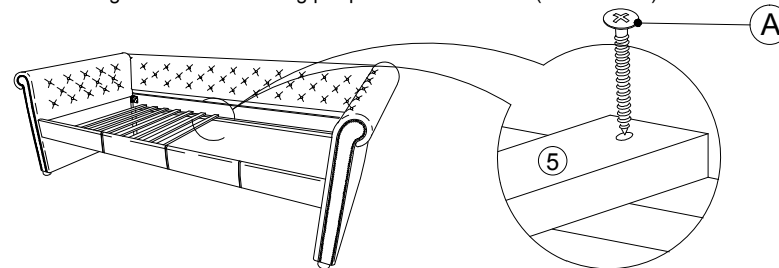

Your new day bed is now complete

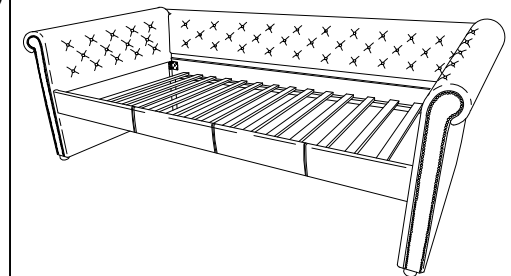

NOTE: AFTER A FEW DAYS OF ASSEMBLY, IT WILL HAVE ACCLIMATIZED TO THE ENVIRONMENT. PLEASE TIGHTEN ALL HARDWARE. CHECK TIGHTNESS OF ALL SCREWS EVERY 6-8 WEEKS.

15-AUG-16

PG : 1 / 1