





Assembly Instructions

BAR TABLE

TST300BTSP

Caution: Please read instructions thoroughly before unpacking assembly parts. Sharp, exposed staple tips can cause injury, therefore, for your protection, please remove any exposed staples used in packing.

1. We recommend that you should assemble this product with the assistance of another person; this will make assembly easier, and will help to eliminate damage to the product or injury to persons during assembly.
2. Be sure to check all packing materials carefully for small parts that may have come loose inside the carton during shipment.
3. Please do not over tighten screws or bolts.
4. Please put all parts on a non-abrasive floor before assembly, and follow the assembly steps to assemble your newly purchased product correctly and efficiently.

PART LIST FOR BAR TABLE				HARDWARE LIST PACKED INSIDE BOX			
No.	PART DESC	CODE.	Q'TY	No.	HARDWARE DESC	CODE.	Q'TY
A	BAR TABLE TOP		1	1	 ALLEN BOLT (5/16" x 60mm)	PTST300BTSPHW1	8
B	BAR TABLE LEFT & RIGHT LEGS SET (2PCS /1SET)	PTST300BTSPLEG1	4	2	 SPRING WASHER (5/16")		8
C	BAR TABLE SIDE STRETCHER SET (2PCS/1SET)	PTST300BTSPSTR1	2	3	 FLAT WASHER (5/16")		8
D	BAR TABLE CENTER STRETCHER	PTST300BTSPSTR2	1	4	 ALLEN KEY (M4)		1
				5	 SCREWS (M4x38mm)		6

STEP:1

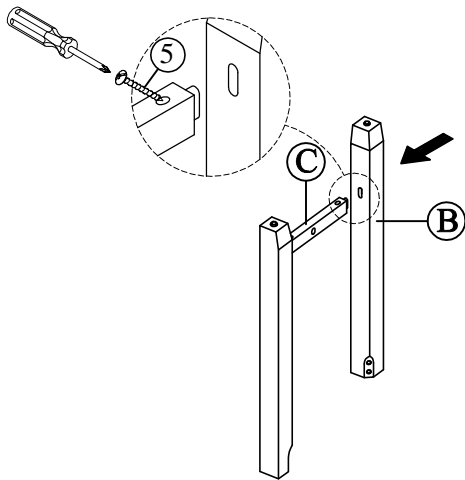

STEP:2

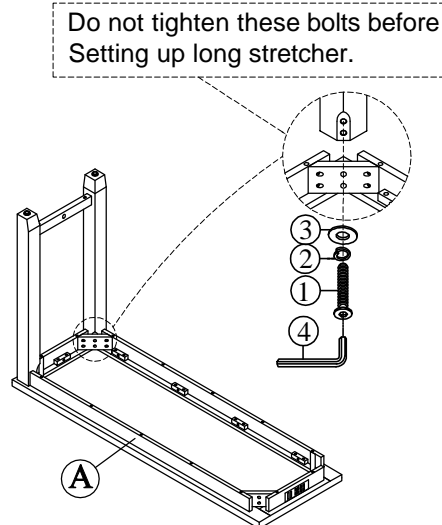

STEP:3

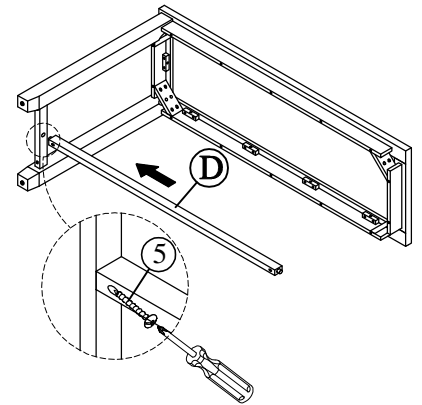

STEP:4

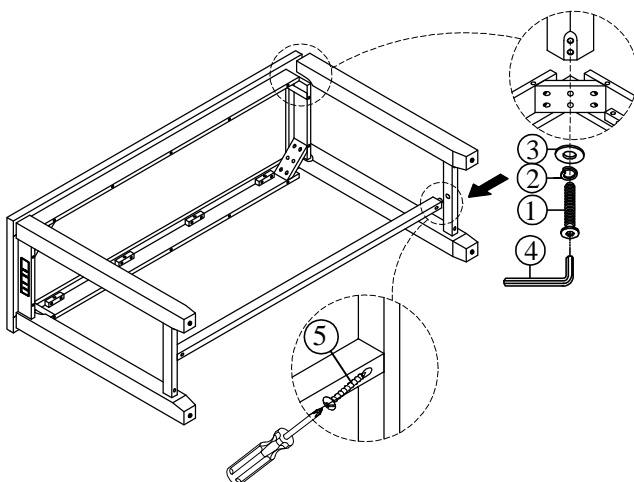

COMPLETED

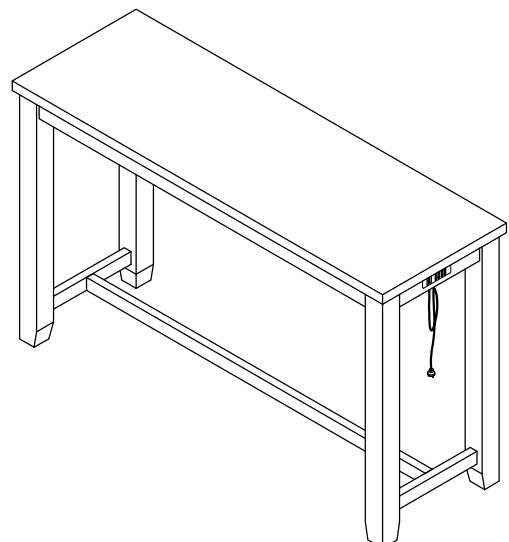

Assembly Instructions





BAR STOOL

TST300BTSP

Caution: Please read instructions thoroughly before unpacking assembly parts. Sharp, exposed staple tips can cause injury, therefore, for your protection, please remove any exposed staples used in packing.

1. We recommend that you should assemble this product with the assistance of another person; this will make assembly easier, and will help to eliminate damage to the product or injury to persons during assembly.
2. Be sure to check all packing materials carefully for small parts that may have come loose inside the carton during shipment.
3. Please do not over tighten screws or bolts.
4. Please put all parts on a non-abrasive floor before assembly, and follow the assembly steps to assemble your newly purchased product correctly and efficiently.

PART LIST FOR HARDY BAR STOOL			
No.	PART DESC	CODE.	Q'TY
A	BAR STOOL SEAT FRAME WITH CUSHION	PTST300BSTSEA	1
B	BAR STOOL LEFT & RIGHT LEGS SET (2 SETS)	PTST300BSTLEG2	4
C	BAR STOOL LONG STRETCHER	PTST300BSTSTR3	2
D	BAR STOOL SHORT STRETCHER	PTST300BSTSTR4	2

HARDWARE LIST PACKED INSIDE BOX			
No.	HARDWARE DESC	CODE.	Q'TY
1	 ALLEN BOLT (1/4" x 60mm)	PTST300BSTHW2	8
2	 SPRING WASHER (1/4")		8
3	 FLAT WASHER (1/4")		8
4	 ALLEN KEY (M4)		1
5	 SCREWS (M4x38mm)		8

STEP:1

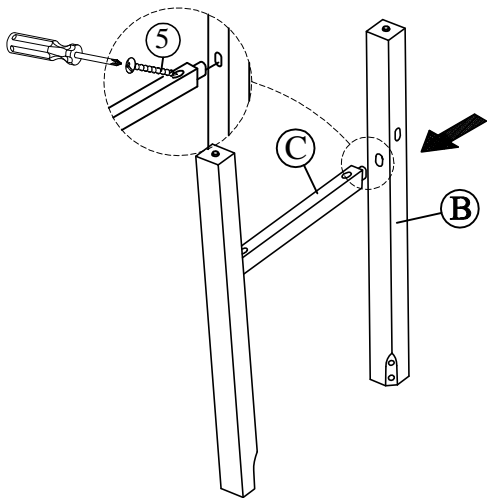

COMPLETED

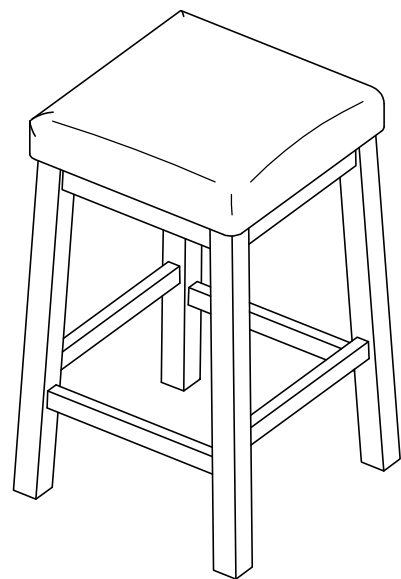

STEP:2

