

ASSEMBLY INSTRUCTION FOR ACME FURNITURE

MODEL#OF00995/OF00987/OF00988

Thank you for purchasing the quality product. Be sure to check all packing material carefully for small parts which may have come loose inside the carton during shipment. Separate, identify and count all parts and metal hardware. Compare with all parts list to be sure all parts are present. If any part(s) are missing or damaged, please contact your local furniture dealer. For efficient and speedy service, please indicate the model number and code letter of part(s) needed.

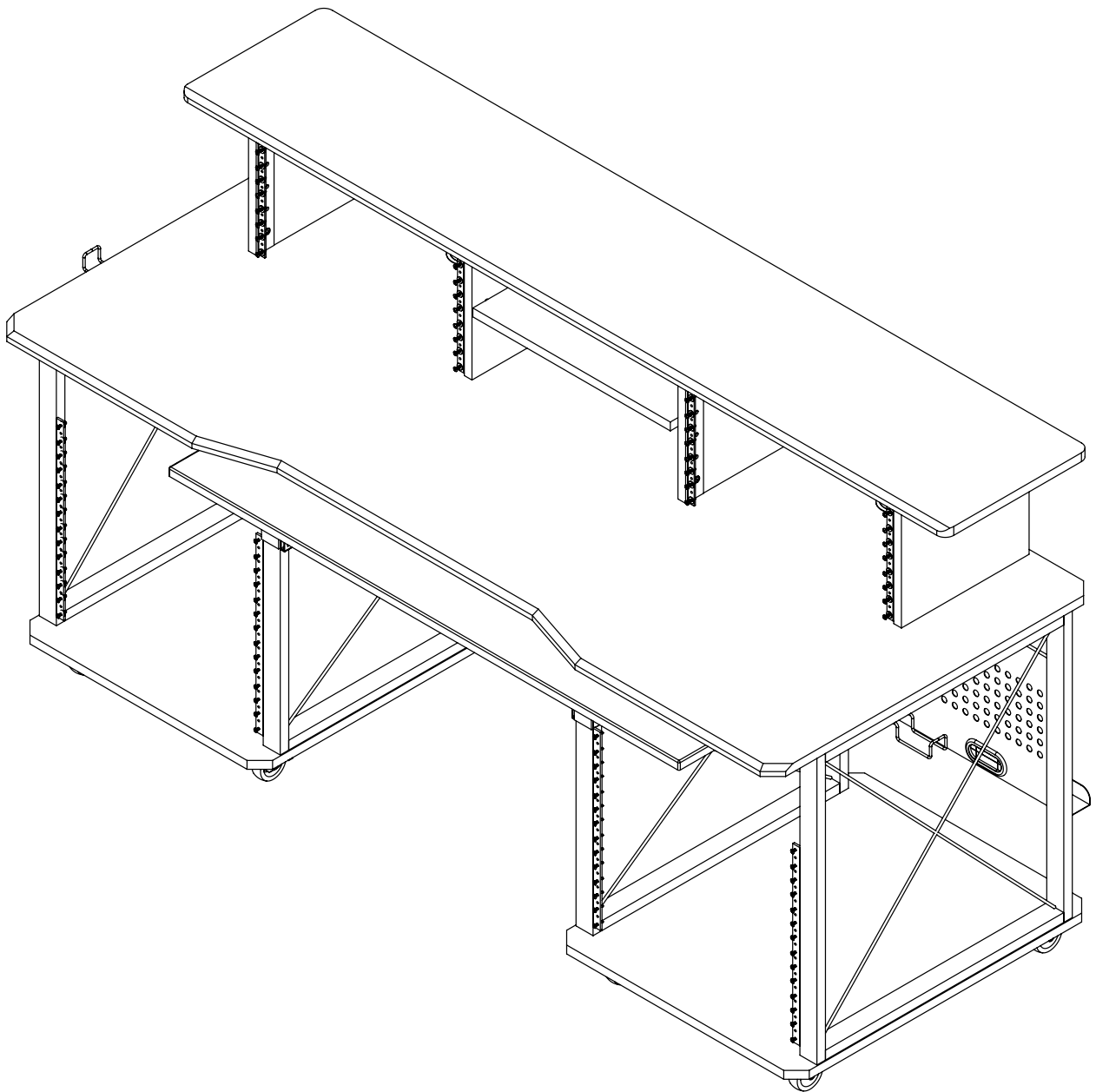



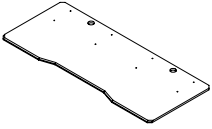
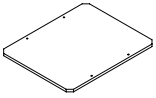
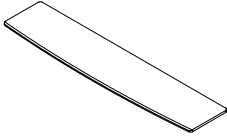
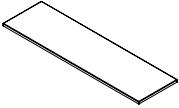
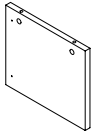
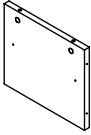
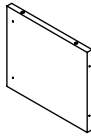
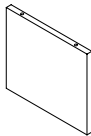
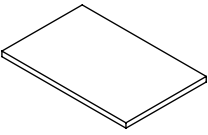
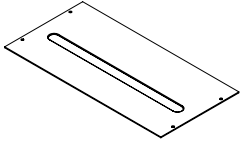
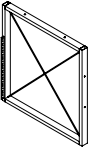

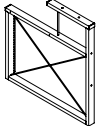
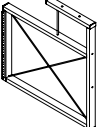
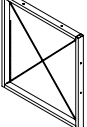
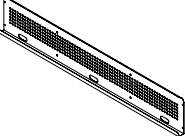
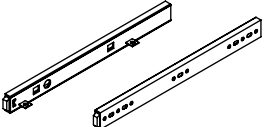
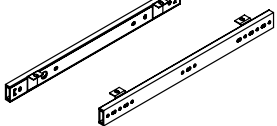
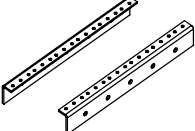
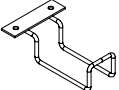
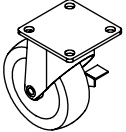
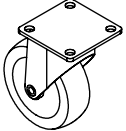
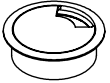
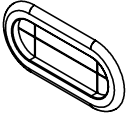

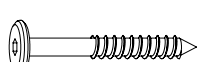

** Do not fully tighten screws until fully assembled **

COMPONENT PARTS		
DESCRIPTION	PART NAME	QTY(PCS)
①	DESKTOP 	1
②	BOTTOM SHELF 	2
③	TOP SHELF 	1
④	KEYBOARD SHELF 	1
⑤	OUTSIDE PANEL-L 	1
⑥	INSIDE PANEL-L 	1
⑦	INSIDE PANEL-R 	1
⑧	OUTSIDE PANEL-R 	1
⑨	MIDDLE SHELF 	1
⑩	WOOD PANEL 	1
⑪	OUTSIDE FRAME-L 	1

⑫	INSIDE FRAME-L		1
⑬	INSIDE FRAME-R		1
⑭	OUTSIDE FRAME-R		1
⑮	REAR PANEL		1
⑯	SHELF SLIDER SET		1
⑰	KEYBOARD SLIDER SET		1
⑱	BRACKET		2
⑲	HEADSET HOLDER		2
⑳	LOCKING CASTERS		2
㉑	NON-LOCKING CASTERS		6
㉒	GROMMET		2
㉓	CORD CLIP		3

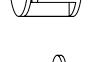
HARDWARE REQUIRED

A		ALLEN BOLT	M6X32MM	16	PCS
B		ALLEN BOLT	M6X12MM	8	PCS
C		ALLEN SCREW	M6X50MM	8	PCS
D		PHILLIPS SCREW	M4X15MM	56	PCS
E		PHILLIPS SCREW	M4X12MM	8	PCS
F		CAM BOLT		8	PCS
G		CAM LOCK		8	PCS
H		PHILLIPS BOLT&WASHER	M5X19MM	100	PCS
I		ALLEN WRENCH		1	PCS

Attention

***Some number parts listed on the instruction sheet may not be in parts bag as they may already be assembled. Carefully check parts and packing materials prior to ordering replacements.

Step1

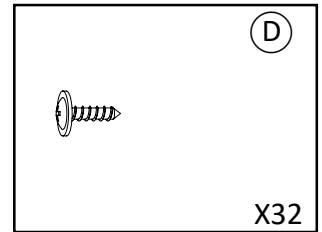
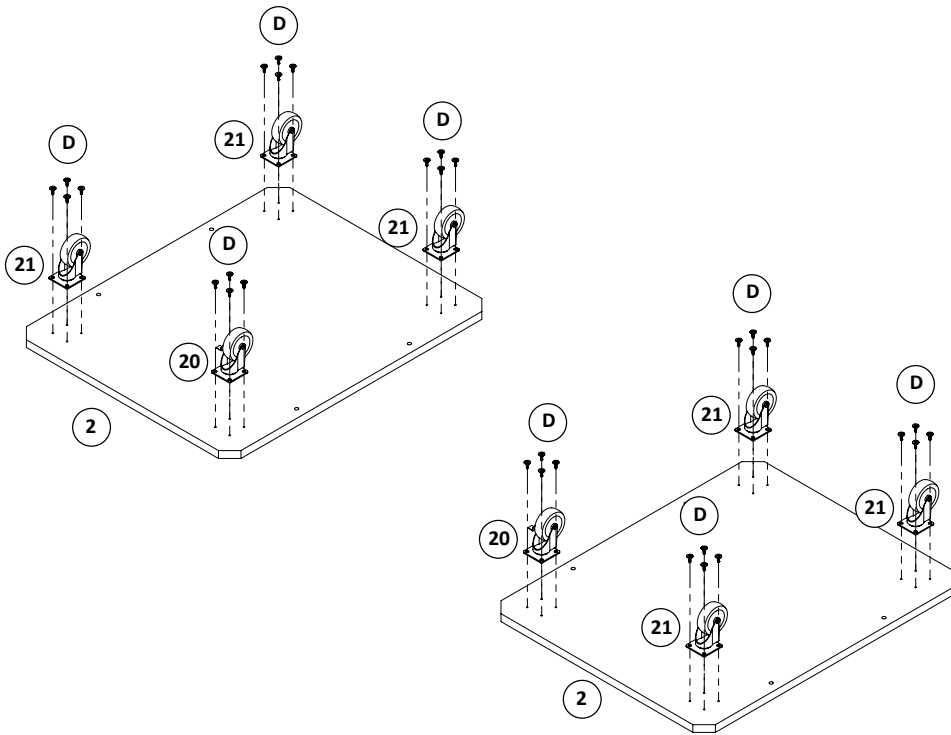

Step2

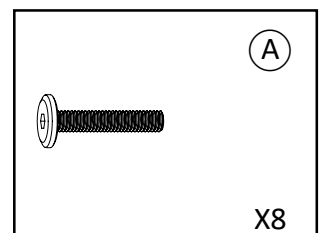
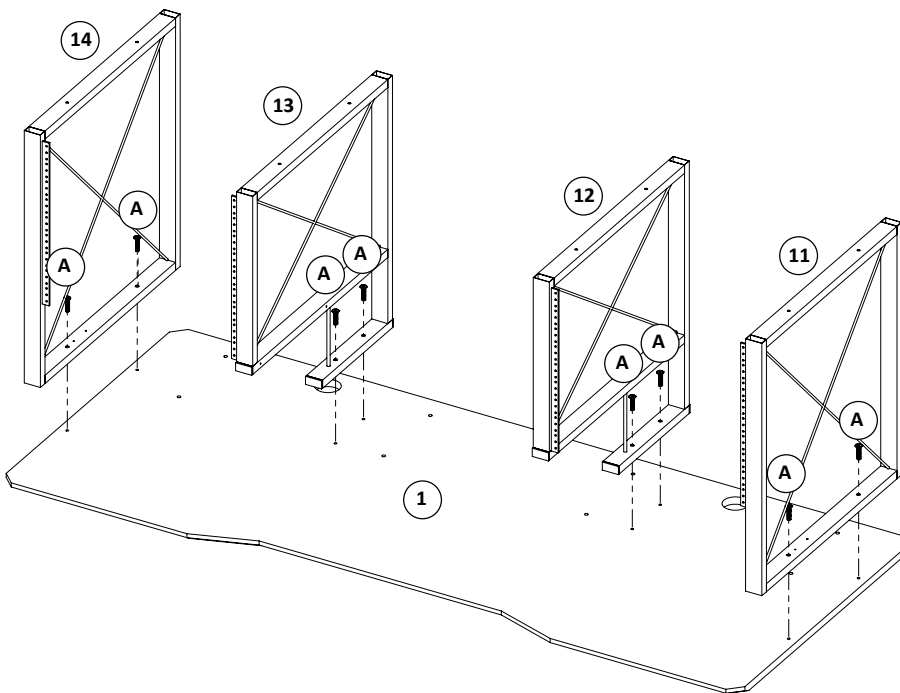

Step3

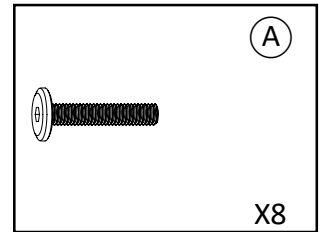
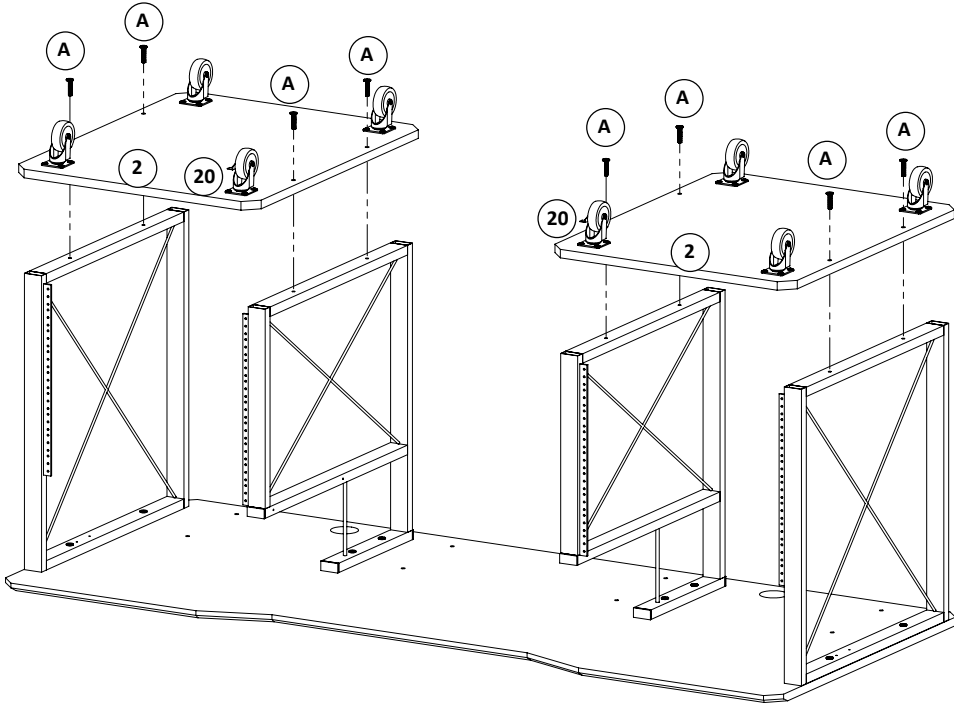

Step4

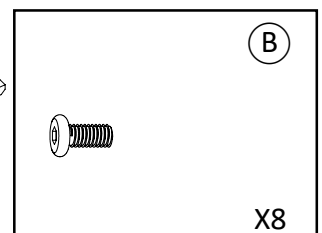
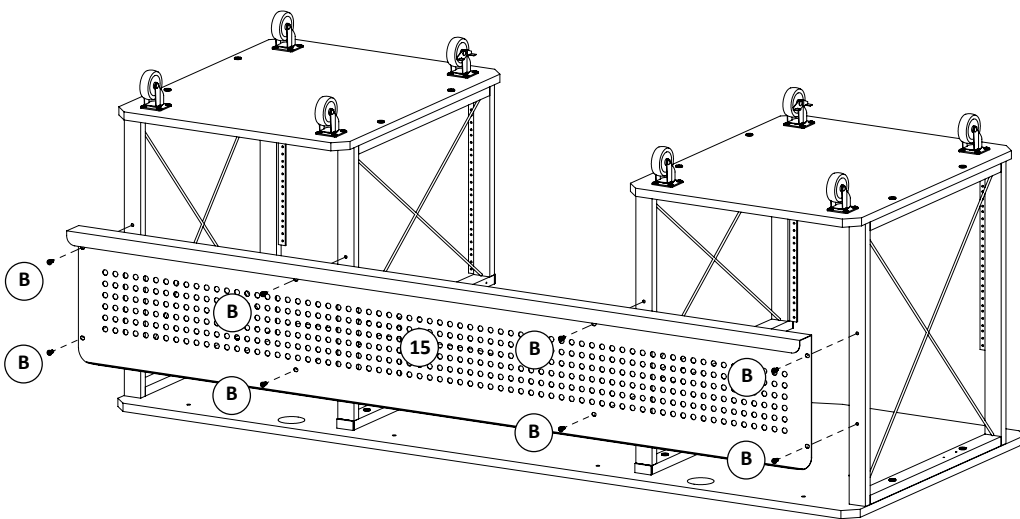

Step 5

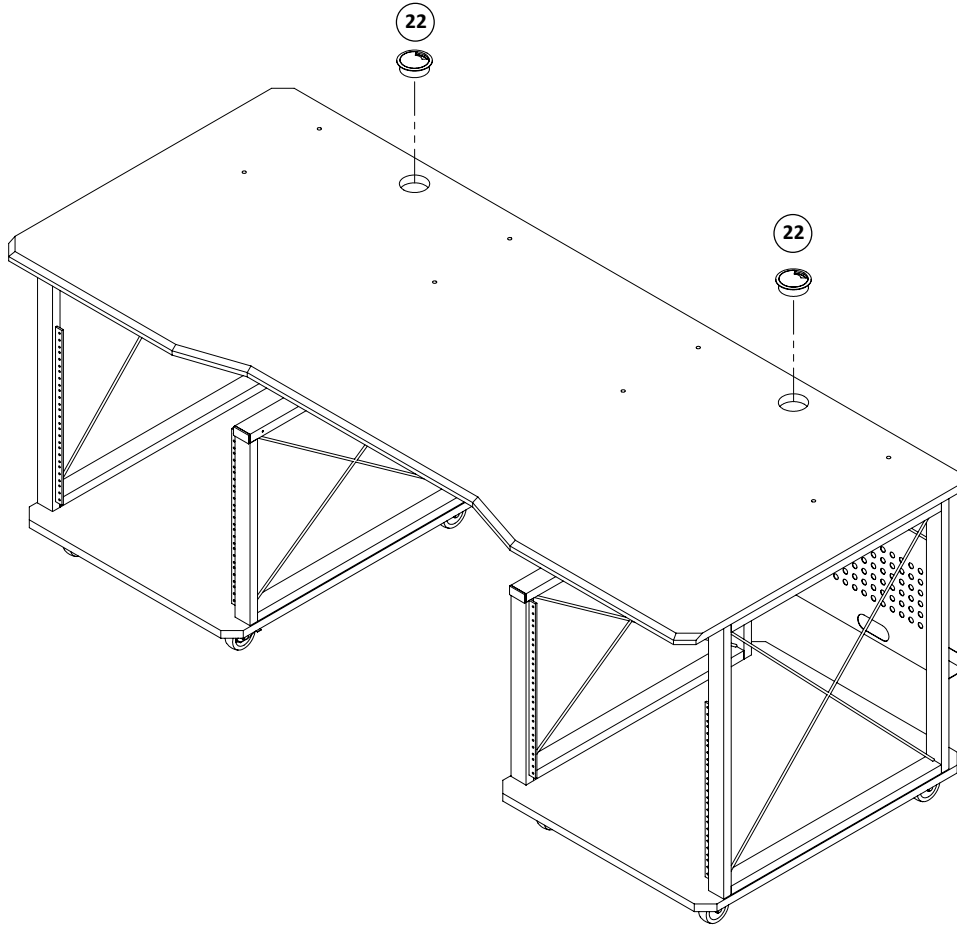

Step 6

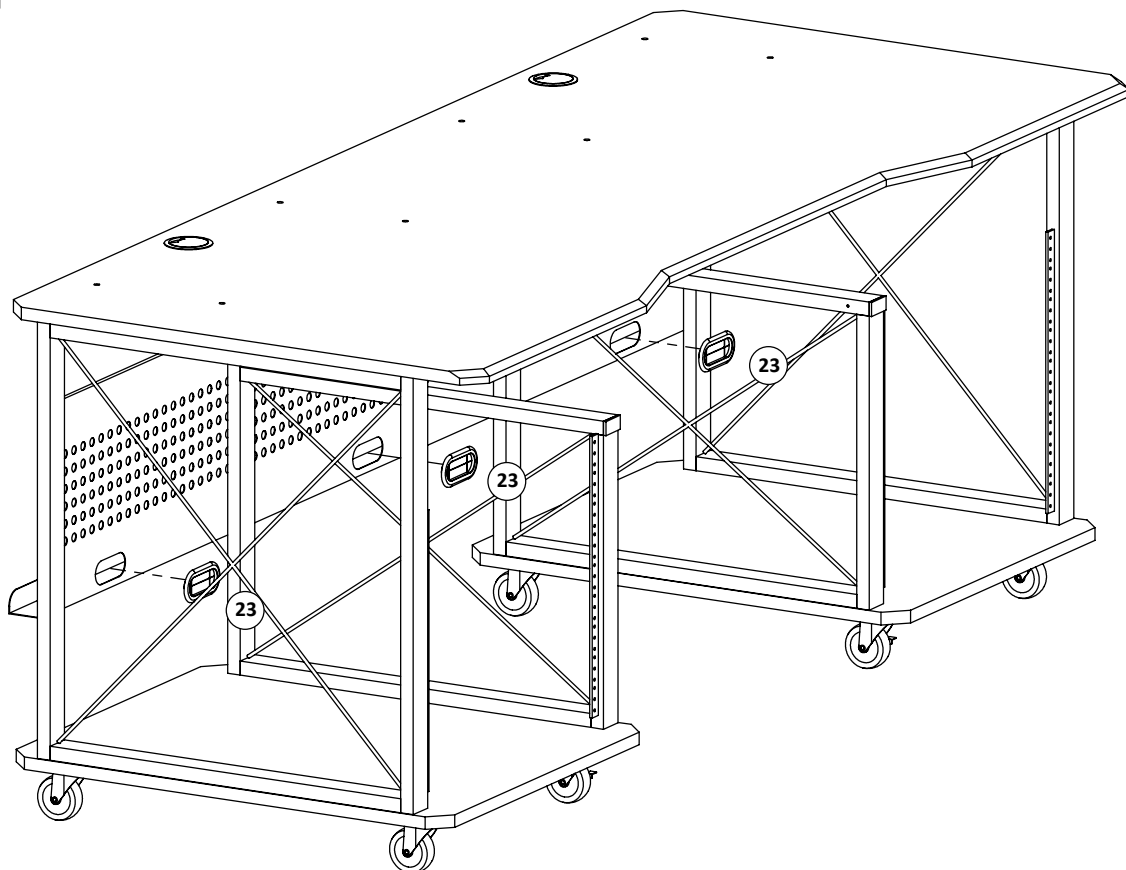

Step 7

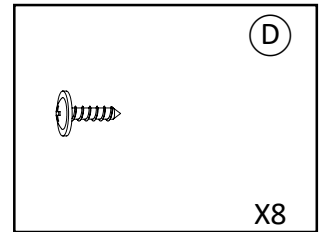
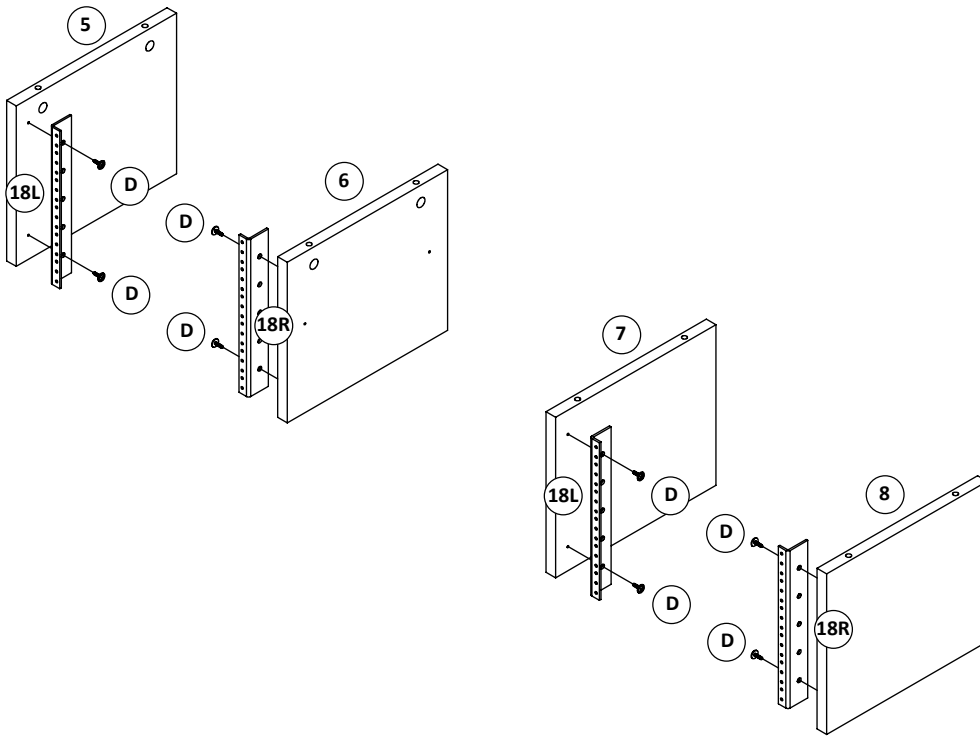

Step 8

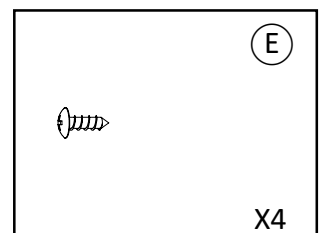
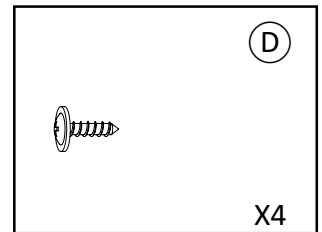
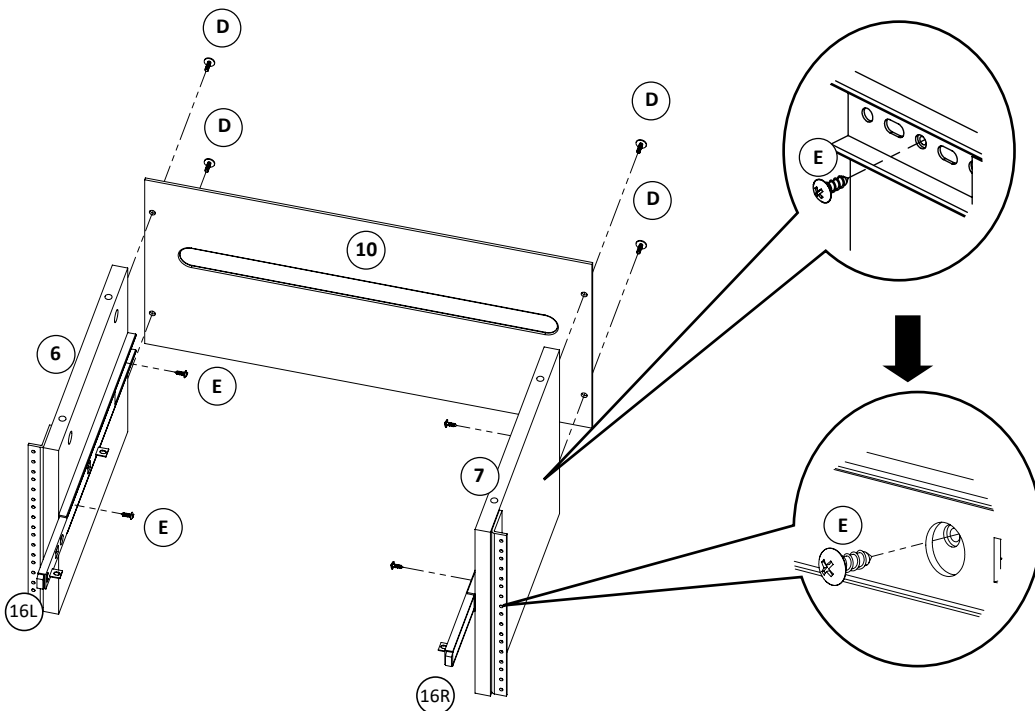

Step 9

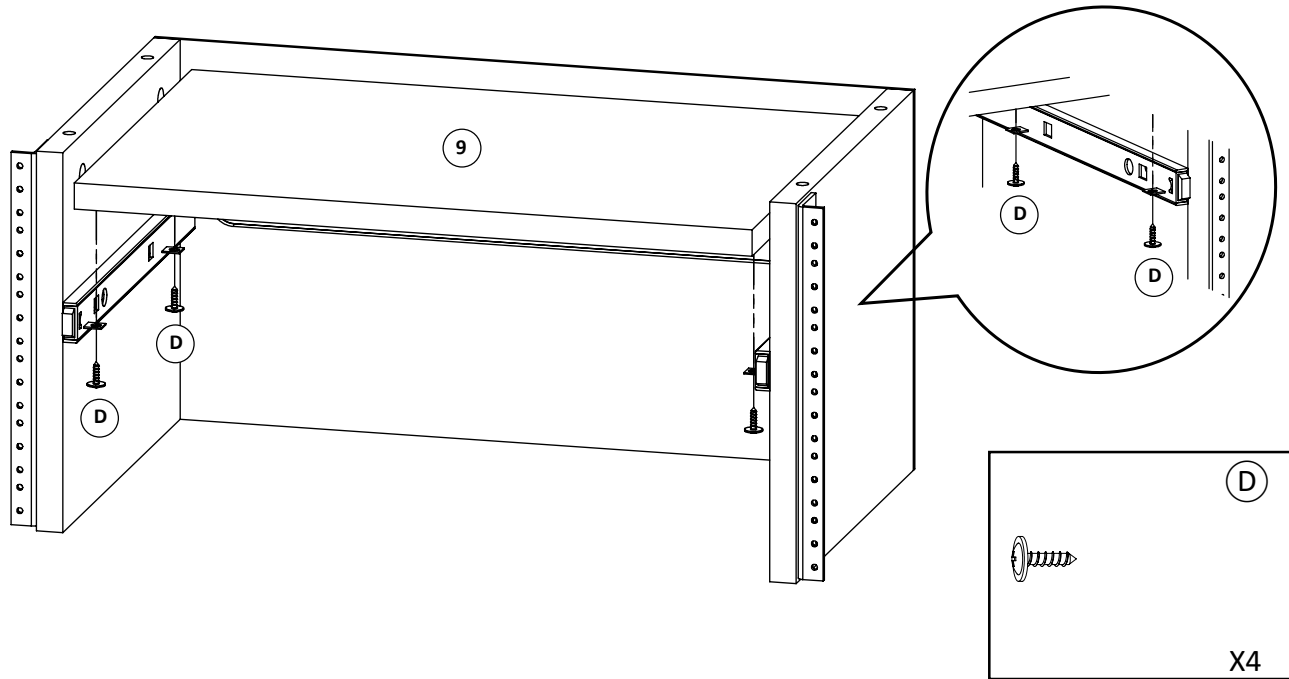

Step 10

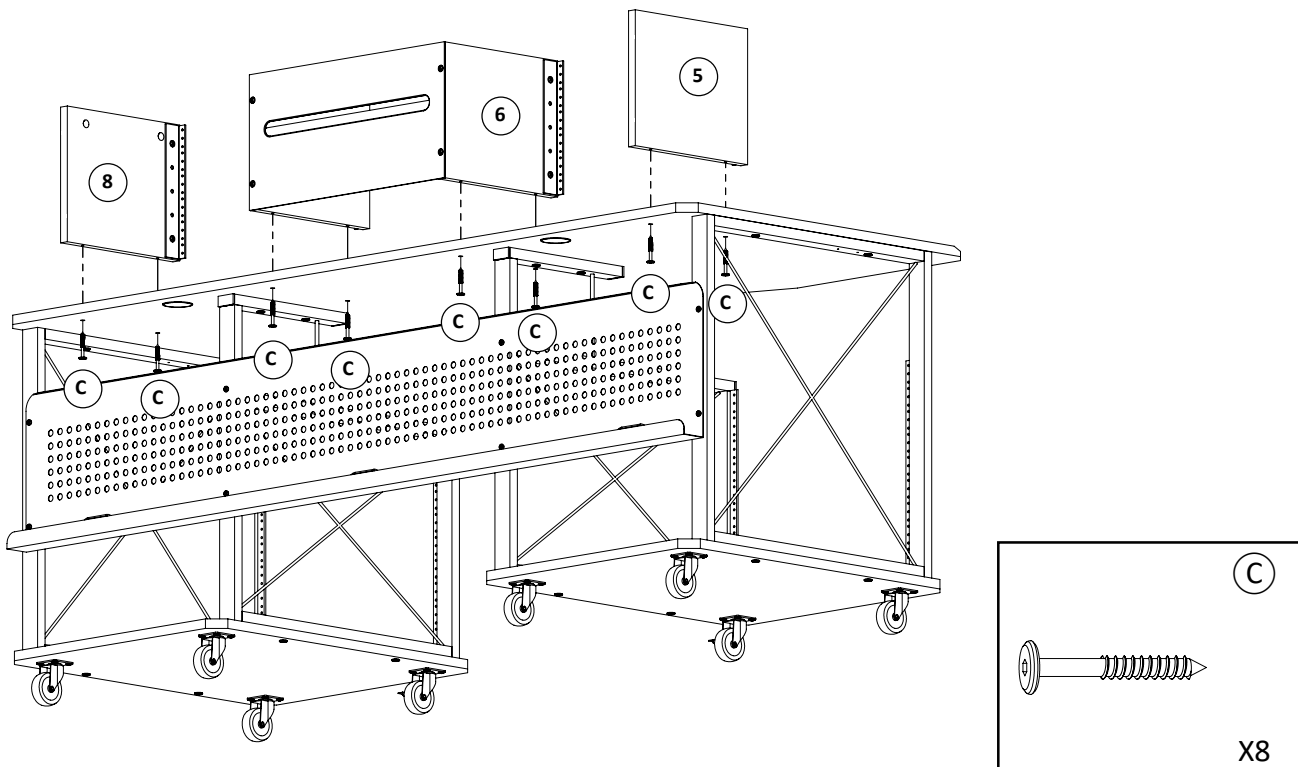

Step11

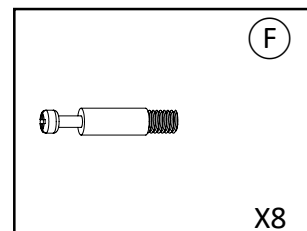
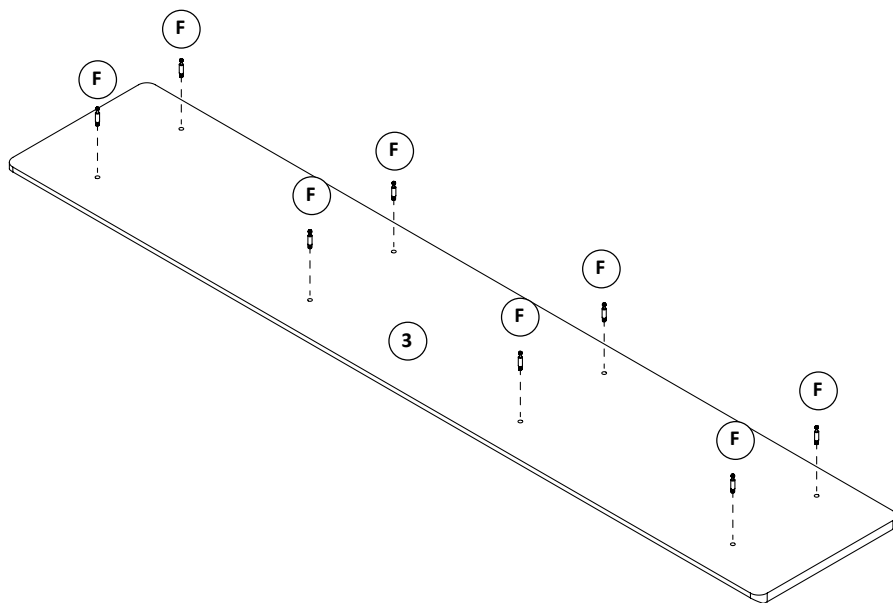

Step12

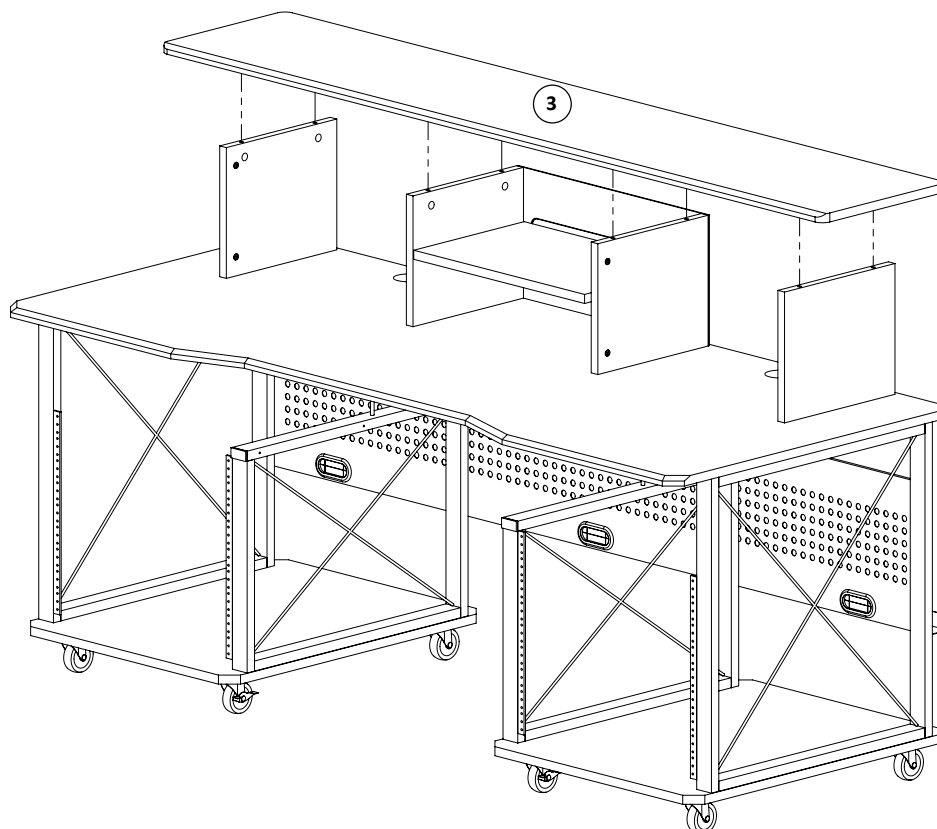

Step13

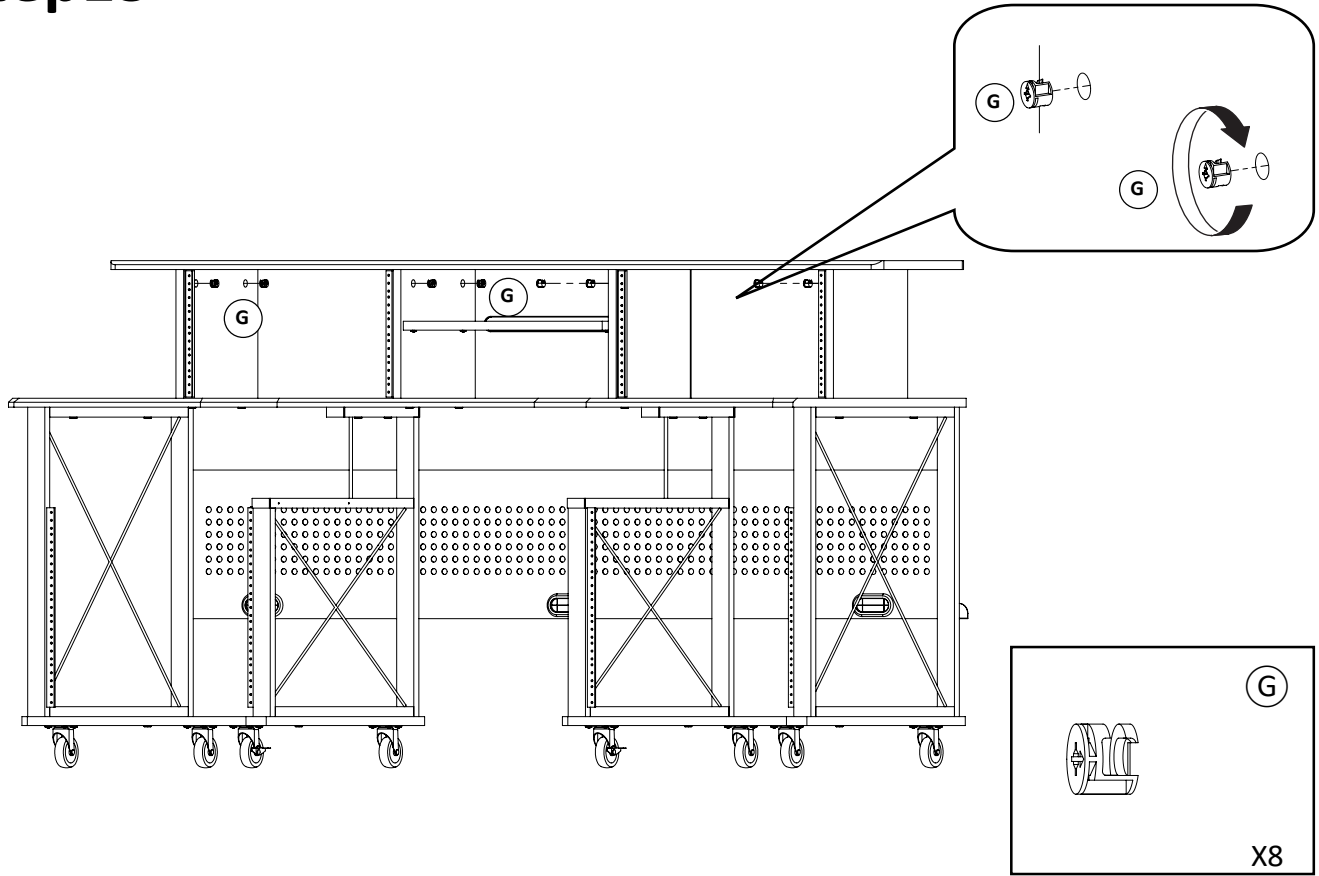

Step14

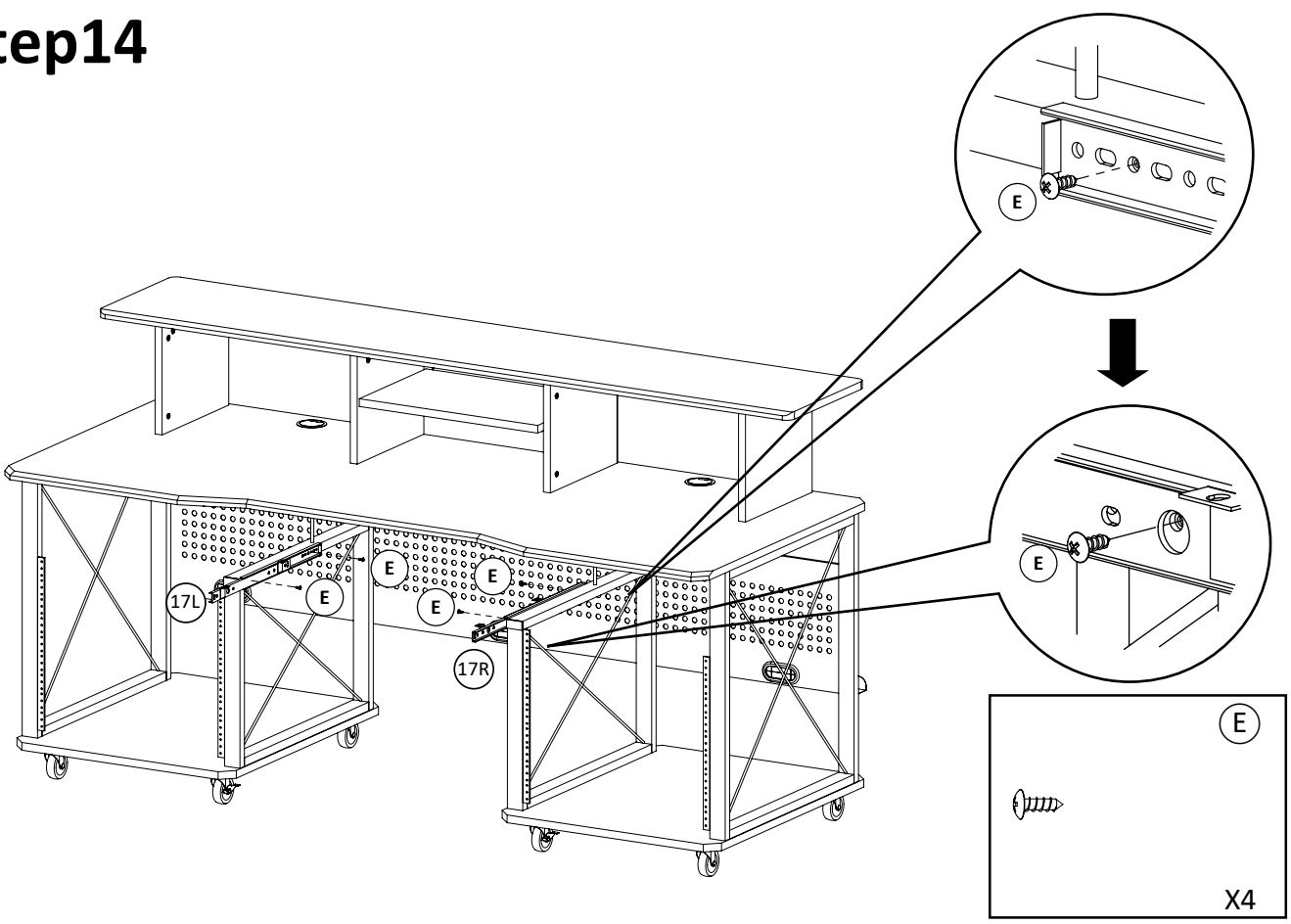

Step15

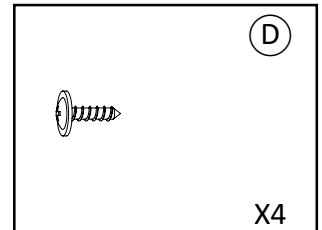
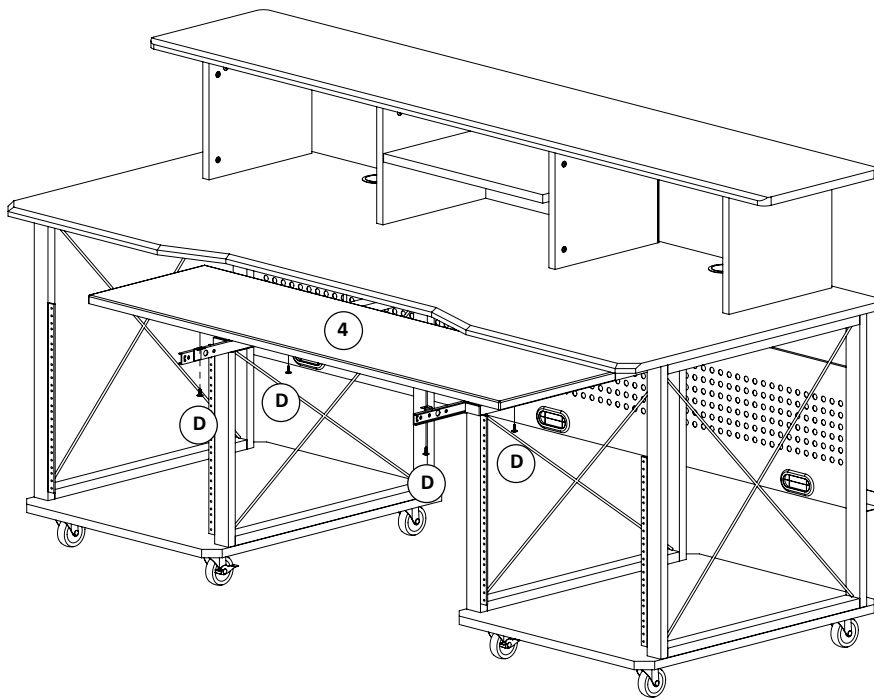

Step16

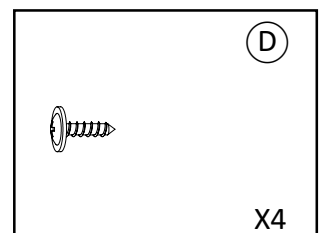
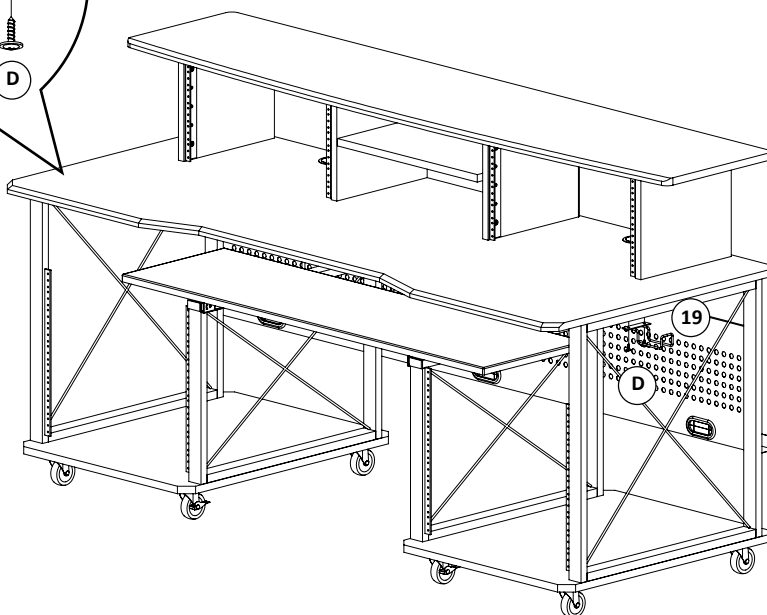
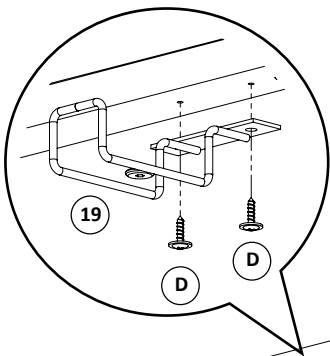

Step17

