

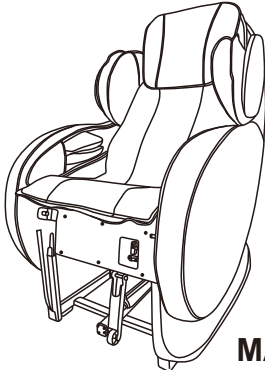

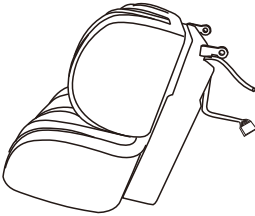



**ASSEMBLY INSTRUCTION FOR ACME FURNITURE
 MODEL#LV00569/LV00570**

Thank you for purchasing the quality product. Be sure to check all packing material carefully for small parts which may have come loose inside the carton during shipment. Separate, Identify and count all parts and metal hardware. Compare with all parts listed to be sure all parts are present. If any part(s) are missing or damaged, please contact your local furniture dealer. For efficient and speedy service, please indicate the model number and code letter of part(s) needed"

****Do not fully tighten screws until fully assembled****

COMPONENT PARTS		
DESCRIPTION	PART NAME	Q'TY (PCS)
①	 MAIN BODY	1
②	 LEG	1

HARDWARE REQUIRED

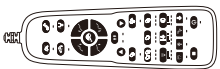
Ⓐ		STOPPER 12mm	2 PCS
Ⓑ		SPRING SPLIT PIN 8*12*35mm	1 PCS
Ⓒ		HOLE BUSHING 8mm	2 PCS
Ⓓ		SHAFT BUSHING φ2*25mm	1 PCS
Ⓔ		PIN SHAFT 8*45mm	1 PCS
Ⓕ		The power cord 2m	1 PCS
Ⓖ		HAND CONTROLLER	1 PCS

Attention

***Some number parts listed on the instruction sheet may not be in parts bag as they may be assembled. Carefully check parts and packing materials prior to ordering replacements. ***

How to assemble & Steps

1

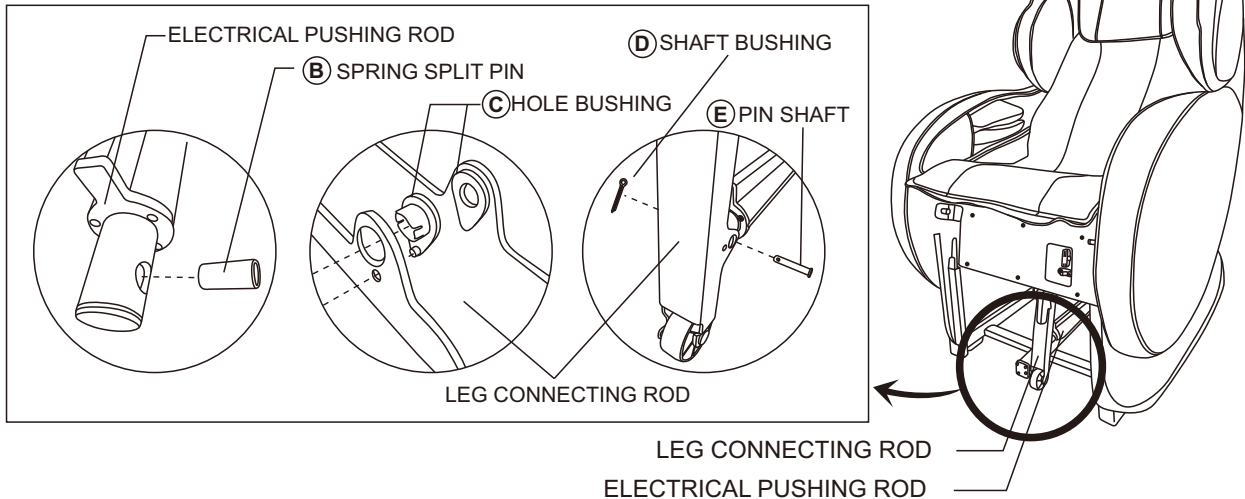

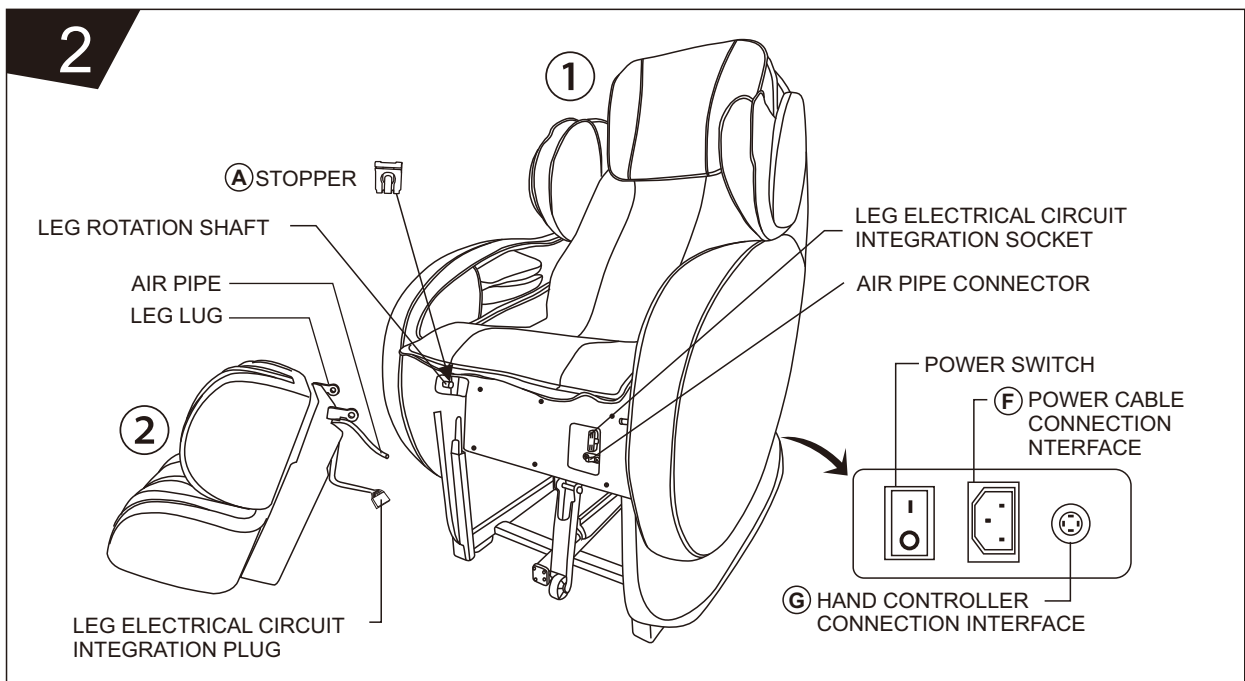

2

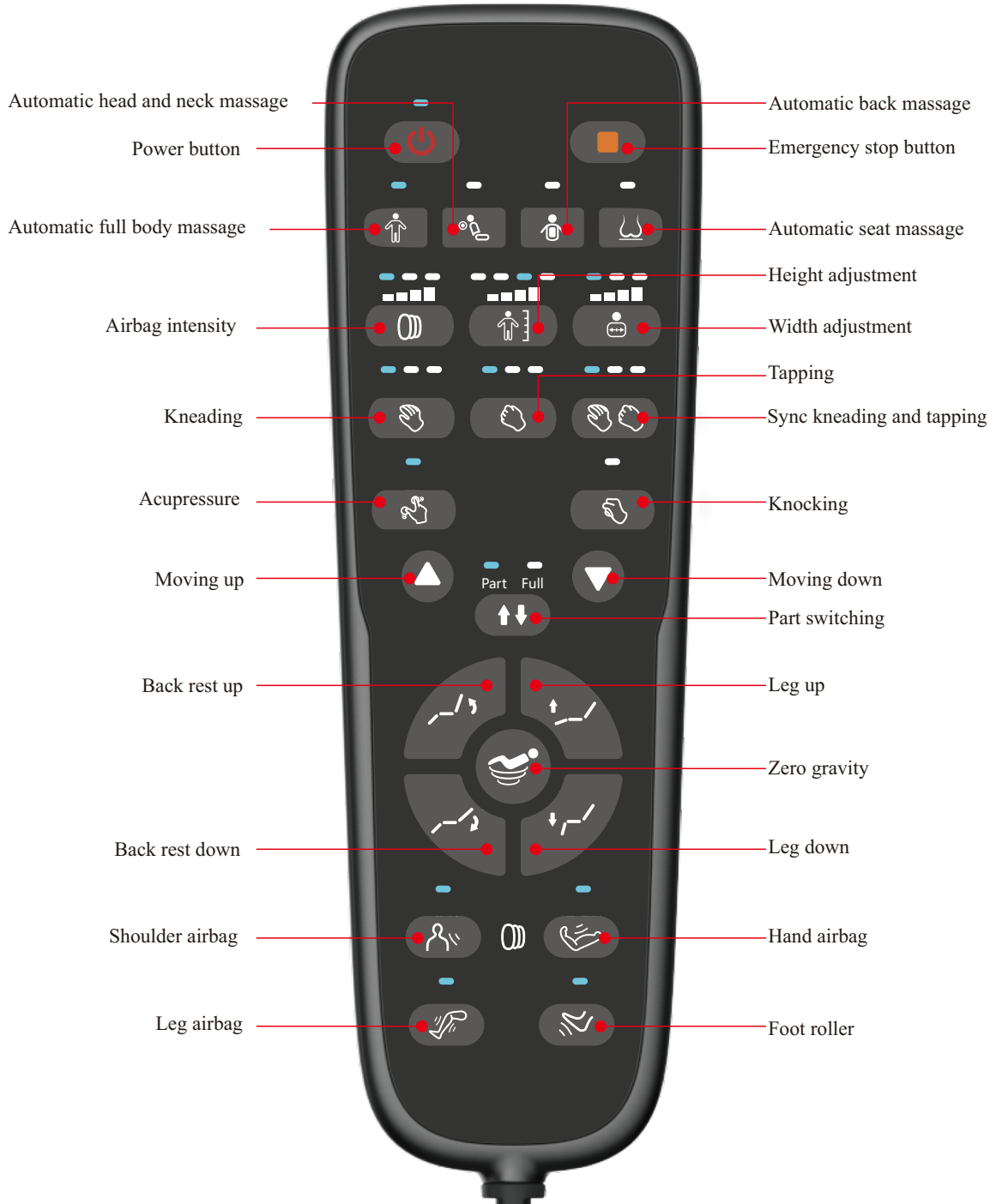

1. First insert the shaft bushing into the round hole in the front of the electric pushing rod, then insert the hole bushing into the hole in the leg connecting rod, insert the pin shaft into the leg connecting rod and the electric pushing rod, and then insert the spring split pin into the pin shaft hole, And then bend both legs.
2. Put one side of the leg's lug onto the leg rotation shaft of the chair, and then put another end onto the corresponding leg rotation shaft, and vertically insert the stopper into the groove in the leg rotation shaft.
3. Insert the air pipe above the leg into the air pipe connector on the seat body, and insert the leg electric circuit integration plug into the leg electric circuit integration socket.
4. Insert the power supply into the power supply socket at the back of the chair, and insert the hand controller into the corresponding hole, and turn on the power to use.

Buttons of Hand Controller and Function Introduction





Caution

- * Do not sit or stack heavy objects on the remote control.
- * Avoid dropping the remote control.
- * Do not apply improper pressure on the remote control.
- * Do not operate the remote control when your hands are wet.
- * Do not operate the remote control with sharp or hard objects to avoid machine failure.



Power Button

When the power indicator is flashing, after pressing the power button, the power light will be continuously on, and the function operation can be performed at this time. If the power indicator is continuously on, after pressing this button, the massage chair will enter the reset state; if pressing this button when it is in the reset state, the massage chair will be stopped in an emergency manner (Pressing any button during the reset process will stop the massage chair in an emergency manner).



Emergency Stop Button

Operating this button in any state will stop the massage in an emergency manner.



Automatic Program 1 (Automatic Full Body Massage)

Operating this button to enter the automatic whole body program and experience a whole body relaxing massage. At the same time, the whole body airbag and the foot roller will be turned on; the chair will enter the zero gravity position. (For the first time entering, the massage chair will prompt you to choose height)



Automatic Program 2 (Automatic Head and Neck Massage)

Operating this button to enter the automatic head and neck program, the program will focus on head, neck and shoulder massage. At the same time, the whole body airbag and the foot roller will be turned on; the chair will enter the zero gravity position. (For the first time entering, the massage chair will prompt you to choose height)



Automatic Program 3 (Automatic Back Massage)

Operating this button to enter the automatic back program, the program will focus on the back and waist massage. At the same time, the whole body airbag and the foot roller will be turned on; the chair will enter the zero gravity position.

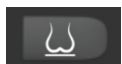

Automatic program 4 (Automatic Seat Massage)

Operating this button to enter the automatic seat program, the program will focus on buttocks and lumbar vertebrae massage. At the same time, the whole body airbag and the foot roller will be turned on; the chair will enter the zero gravity position.



Airbag Intensity

When the airbag is working, operating this button to adjust the intensity of the airbag. If the airbag is not working, operation of this button is invalid.

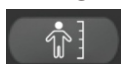

Height

For the first operation of automatic full body or automatic head and neck program, you can choose body size by height key. When the massage core reaches the shoulder height, the buzzer will sound and the height light flashes. After the height is selected, the height of massage core will be adjusted according to the height. There have nine body size and height options, the selected option will be remembered after each adjustment.

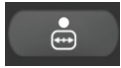

Width Adjustment

In the manual mode, when the massage core is in the tapping, acupressure or knocking mode, this button can be operated to adjust the width of the massage core, including wide, medium and narrow, this button is invalid in other states.

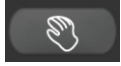

Kneading

Operating this button to enter or exit the massage core kneading. There have three speed options.

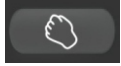

Tapping

Operating this button to enter or exit the massage core tapping. There have three speed options.



Sync Kneading and Tapping

Operating this button to enter or exit the sync massage core kneading and tapping. There have three speed options.

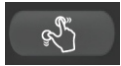

Acupressure

Operating this button to enter or exit the massage core acupressure.



Knocking

Operating this button to enter or exit the massage core knocking.



Part Switching

When the massage core is in the manual mode, pressing this button to switch the massage core among the whole body, part and fixed point.



Moving Up

When the massage core is in the manual fixed point mode, operating this button to move the core upward.



Moving Down

When the massage core is in the manual fixed point mode, operating this button to move the core downward.



Leg Up

Press and hold this button, the leg will be lifted, and stop pressing to stop lifting.



Leg Down

Press and hold this button, the leg will be lowered, and stop pressing to stop lowering.



Back Rest Up

Press and hold this button, the back rest will be lifted, and stops pressing to stop lifting.



Back Rest Down

Press and hold this button, the back rest will be lowered, and stops pressing to stop lowering.



Zero gravity

If the current position is not zero gravity, operating this button to let the massage chair enter the zero gravity state; if the current position is already zero gravity, pressing this button to return the massage chair to the reset position.



Shoulder Airbag

Turn on or off the shoulder airbag.



Hand Airbag

Turn on or off the hand airbag.



Foot Airbag

Turn on or off the foot airbag.



Roller

Turn on or off the roller



Telescopic leg design, safe and comfortable extension spring stretching



Manual function setting, more DIY massage programs



L-shaped long rail design to increase the massage area



One-touch zero gravity, no stress



Time setting, the default is 15 minutes



Caution

- (1) Do not sit in the massage chair when the kneading leg assembly is adjusted. Applying instantaneous pressure on the kneading leg assembly will result in damage to the mechanism, and may even cause the chair to overturn and result in accidental injury.
- (2) Before sitting in the massage chair, please confirm that the back of the chair is in a vertical state, and then adjust the reclining angle according to personal preference after sitting in.
- (3) Do not place hands or foreign objects into the gap between the chair seat and the chair back or the gap between the chair seat and the kneading leg assembly to prevent accidental injury.
- (4) When adjusting the angle, make sure that there have no obstacles and small animals underneath or in front of the chair