

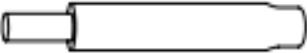





# ITEM NO. 92518 OFFICE CHAIR

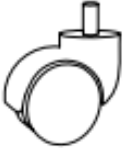

## ASSEMBLY INSTRUCTIONS

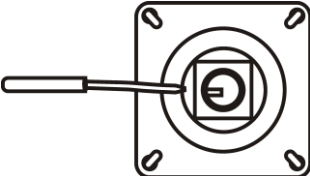
| 1   | 2   | 3  |
|---|---|--|
|  <p data-bbox="233 954 384 1025"><b>GAS LIFT</b><br/>1PC</p> |  <p data-bbox="754 954 842 1025"><b>BASE</b><br/>1PC</p>                 |  <p data-bbox="1155 954 1289 1025"><b>CASTER</b><br/>5PCS</p> |
| 4   | 5   |  |
|  <p data-bbox="268 1496 355 1568"><b>SEAT</b><br/>1PC</p>  |  <p data-bbox="663 1496 1007 1568"><b>BRACKET W/HANDLE</b><br/>1PC</p> |  |
| A   | B   |  |
|  <p data-bbox="264 2000 355 2072"><b>BOLT</b><br/>4PCS</p> |  <p data-bbox="743 2000 890 2072"><b>WRENCH</b><br/>1PC</p>            |  |

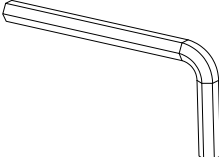
## STEP 1

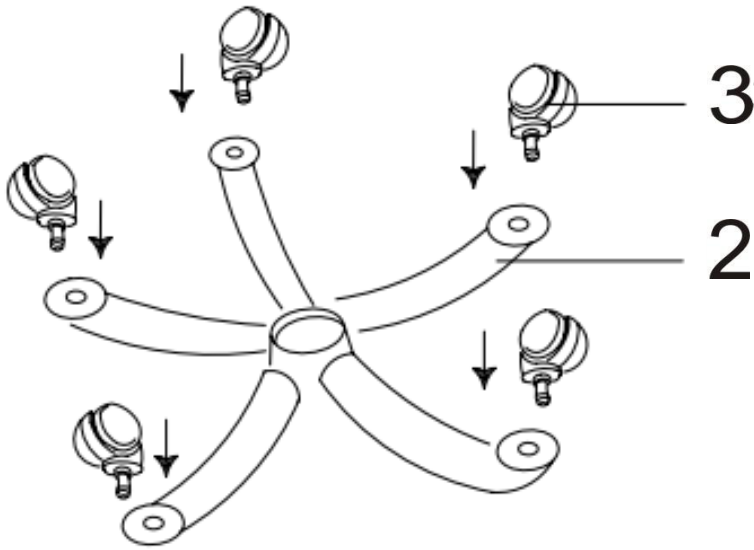

\*Please put all parts on a soft surface to prevent scratches.

Insert caster (3) into base (2) carefully as shown.

## STEP 2

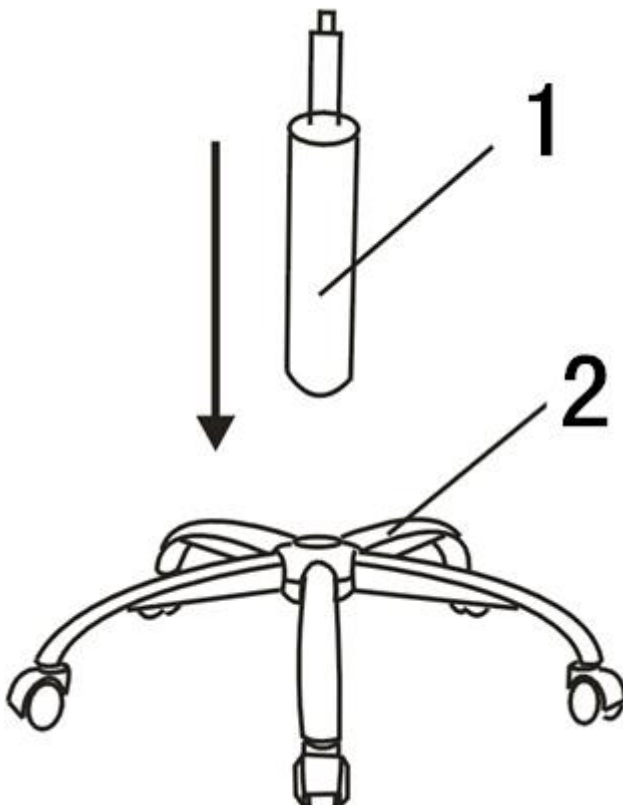

Insert gas lift (1) into base (2) carefully as shown.

### STEP 3

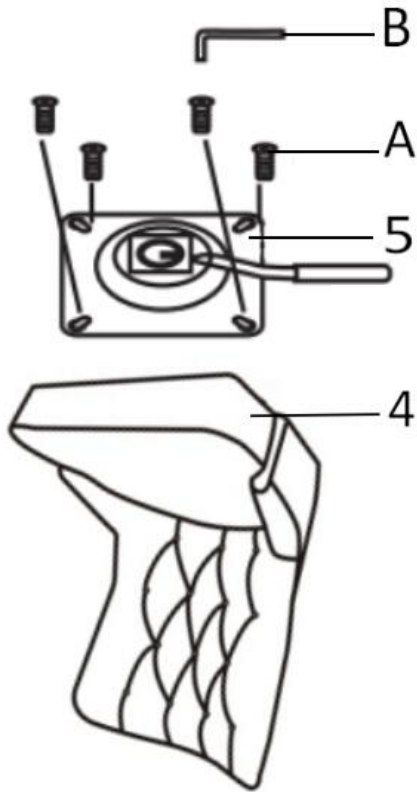

Attach bracket w/handle (5) to seat (4) by using bolt (A) and wrench (B) as shown.

Tighten all bolts firmly!

### STEP 4

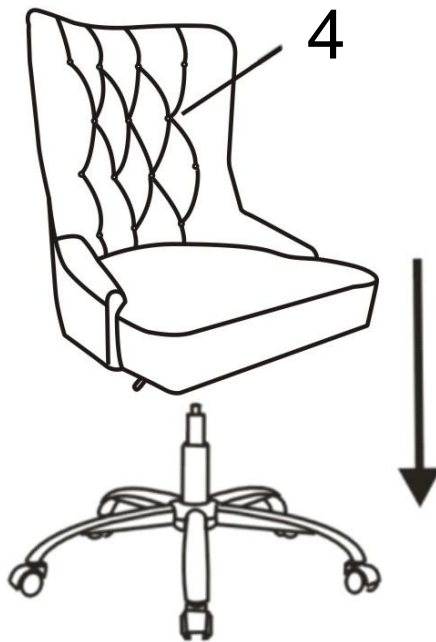

Insert gas lift (1) into seat (4) by applying moderate downwards force to the seat (4) in order to secure it to the base as shown.

Your office chair is completed.