

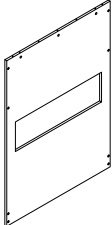

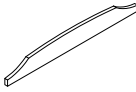

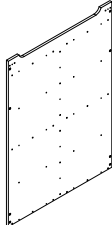







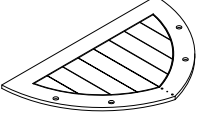
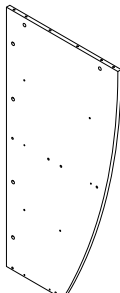

ASSEMBLY INSTRUCTION FOR ACME FURNITURE

MODEL # BD00577

Thank you for purchasing the quality product. Be sure to check all packing material carefully for small parts which may have come loose inside the carton during shipment. Separate, identify and count all parts and metal hardware. Compare with all parts list to be sure all parts are present. If any part(s) are missing or damaged, please contact your local furniture dealer. For efficient and speedy service, please indicate the model number and code letter of part(s) needed.

***** Do not fully tighten screws until fully assembled *****

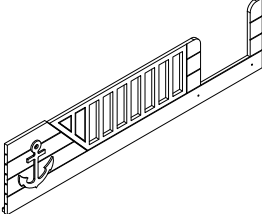
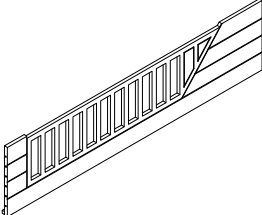
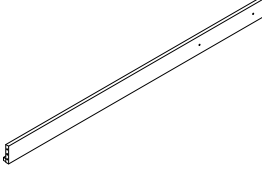
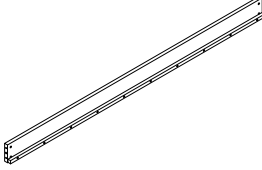
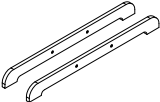
COMPONENT PARTS		
DESCRIPTION	PART NAME	Q'TY (PCS)
①	HEADBOARD PANEL 	1
②	HEADBOARD TOP RAIL 	1
③	FOOTBOARD PANEL 	1
④L	FOOTBOARD TOP RAIL (L) 	1
④R	FOOTBOARD TOP RAIL (R) 	1
⑤	CENTER BLOCK 	1
⑥	ROUND STICK 	4
⑦	TOP PANEL 	1
⑧	CENTER PANEL 	1

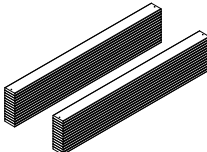
COMPONENT PARTS		
DESCRIPTION	PART NAME	Q'TY (PCS)
9L	TOP SHELF (L) 	1
9R	TOP SHELF (R) 	1
10L	2ND SHELF (L) 	1
10R	2ND SHELF (R) 	1
11L	3RD SHELF (L) 	1
11R	3RD SHELF (R) 	1
12L	BOTTOM RAIL (L) 	1
12R	BOTTOM RAIL (R) 	1
13	GUARDRAIL (FRONT) 	1
14	GUARDRAIL (REAR) 	1
15	SIDERAIL (FRONT) 	1
16	SIDERAIL (REAR) 	1
17	LADDER SIDE 	2
18	LADDER SLAT 	2
19	WOODEN SLAT 	13 + 13

HARDWARE REQUIRED

A		PLASTIC DOWEL	M8 x 30MM	50 PCS
B		PLASTIC DOWEL	M10 x 35MM	28 PCS
C		WOOD DOWEL	M8 x 50MM	4 PCS
D		JCBC BOLT	M6 x 35MM	4 PCS
E		JCBC BOLT	M6 x 50MM	20 PCS
F		JRN NUT	M6 x 13MM	20 PCS
G		CONNECTING BOLT	34MM	34 PCS
H		MINIFIX	12MM	34 PCS
J		CSK C/B SCREW	M3.5 x 16MM	16 PCS
K		CSK C/B SCREW	M4 x 32MM	12 PCS
L		BASE GLIDE L190	M6 x 23MM	5 PCS
M		1225 SHELF SUPPORT	-	16 PCS
N		ALLEN KEY	M4 x 60MM	1 PC
P		FURNITURE GLUE 10G	-	1 PC

***Tools Required : Crosshead Screw Driver**

READ THESE INSTRUCTIONS CAREFULLY BEFORE ATTEMPTING TO ASSEMBLE THIS BED.

F1427-13 SAFETY WARNINGS AND GENERAL NOTES:

- Follow the information on the warnings appearing on the upper bunk bed end structure and on the carton. Do not remove the warning label from the bed.
- Always use the recommended size mattress or mattress support, or both, to help prevent the likelihood of entrapment or falls.
- The top surface of the mattress must be at least 5" below the upper edge of the guardrails.
- Do not allow children under 6 years of age to use the upper bunk.
- Periodically check and ensure the guardrail, ladder and other components are in their proper position, free from damage, and all connectors are tight.
- Prohibit horseplay on or under the bed. Always prohibit jumping on the bed.
- Prohibit more than one person on upper bunk.
- Always use the ladder for entering and leaving the upper bunk.
- Do not use substitute parts. Contact the manufacturer or dealer for replacement parts.
- Use of a night-light may provide added safety precaution for a child using the upper bunk.
- Always use guardrails on both long sides of the upper bunk.
- If the bunk bed will be placed next to a wall, the guardrail that runs the full length of the bed should be placed against the wall to prevent entrapment between the bed and the wall.
- The use of water or sleep flotation mattresses is prohibited.
- Keep these instructions for future reference.
- We recommend assembling your bunk bed on the shipping carton to protect your floor or carpet. Be certain all staples are out of the box before beginning assembly on the shipping carton.

STRANGULATION HAZARD - Never attach or hang items to any part of the bunk bed that are not designed for use with the bed; for example, but not limited to, hooks, belts, and jumpropes.

MATTRESS SIZE

Upper Bunk Mattress Specification :

- Only use a mattress that is 74" - 75" long and 37 1/2" - 38 1/2" wide on upper bunk.
- Ensure thickness of mattress does not exceed 9".

Lower Bunk Mattress Specification :

- Only use a mattress that is 75" long and 39" wide on lower bunk.
- Ensure thickness of mattress is 9" only.

Replacement parts :

Replacement parts, including additional guard rails, can be obtained from any ACME Furniture distributor or retailer.

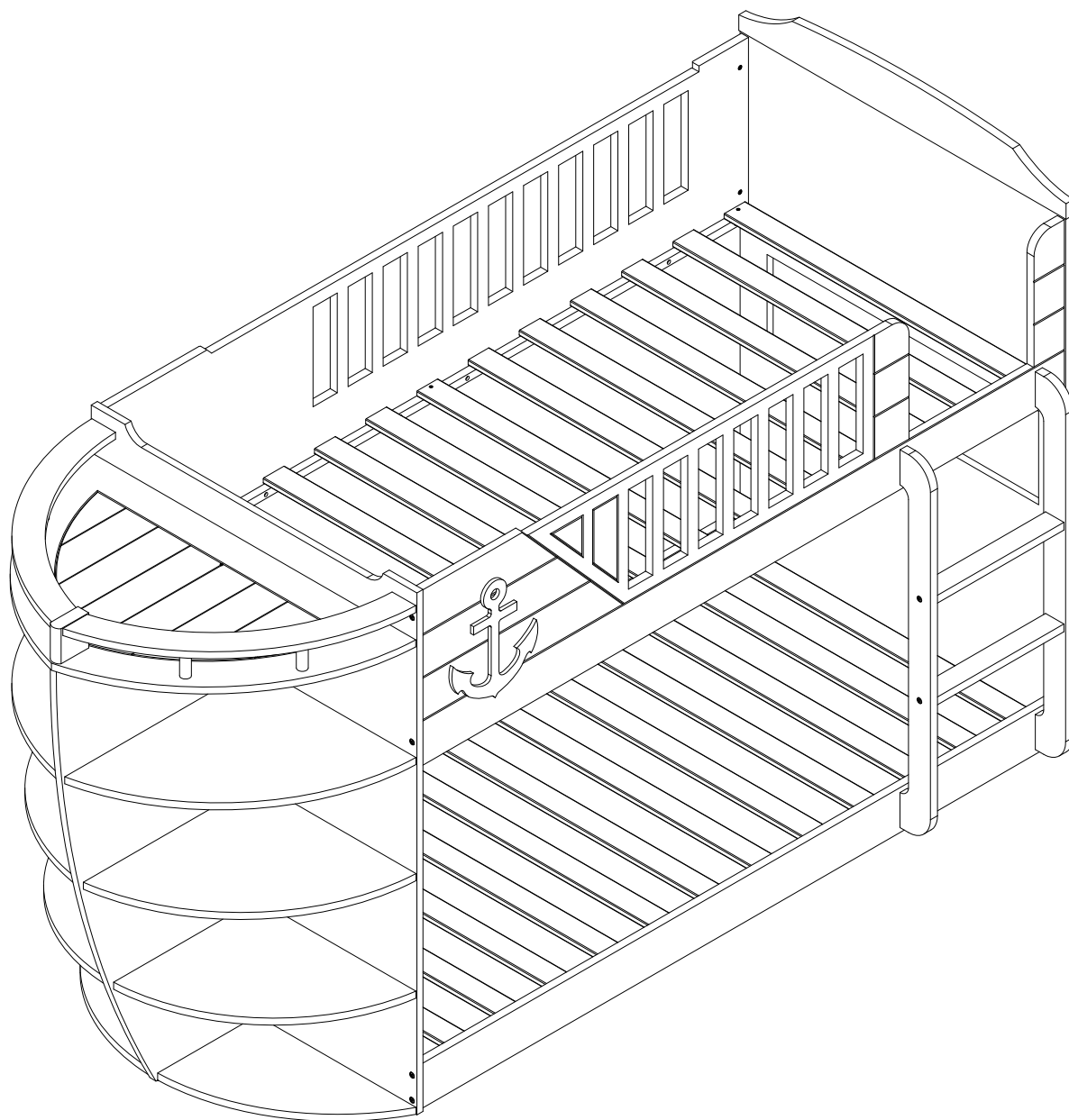

Attention

***Some number parts listed on the instruction sheet may not be in parts bag as they may already be assembled.
Carefully check parts and packing materials prior to ordering replacements.

How to assemble:

STEP 1

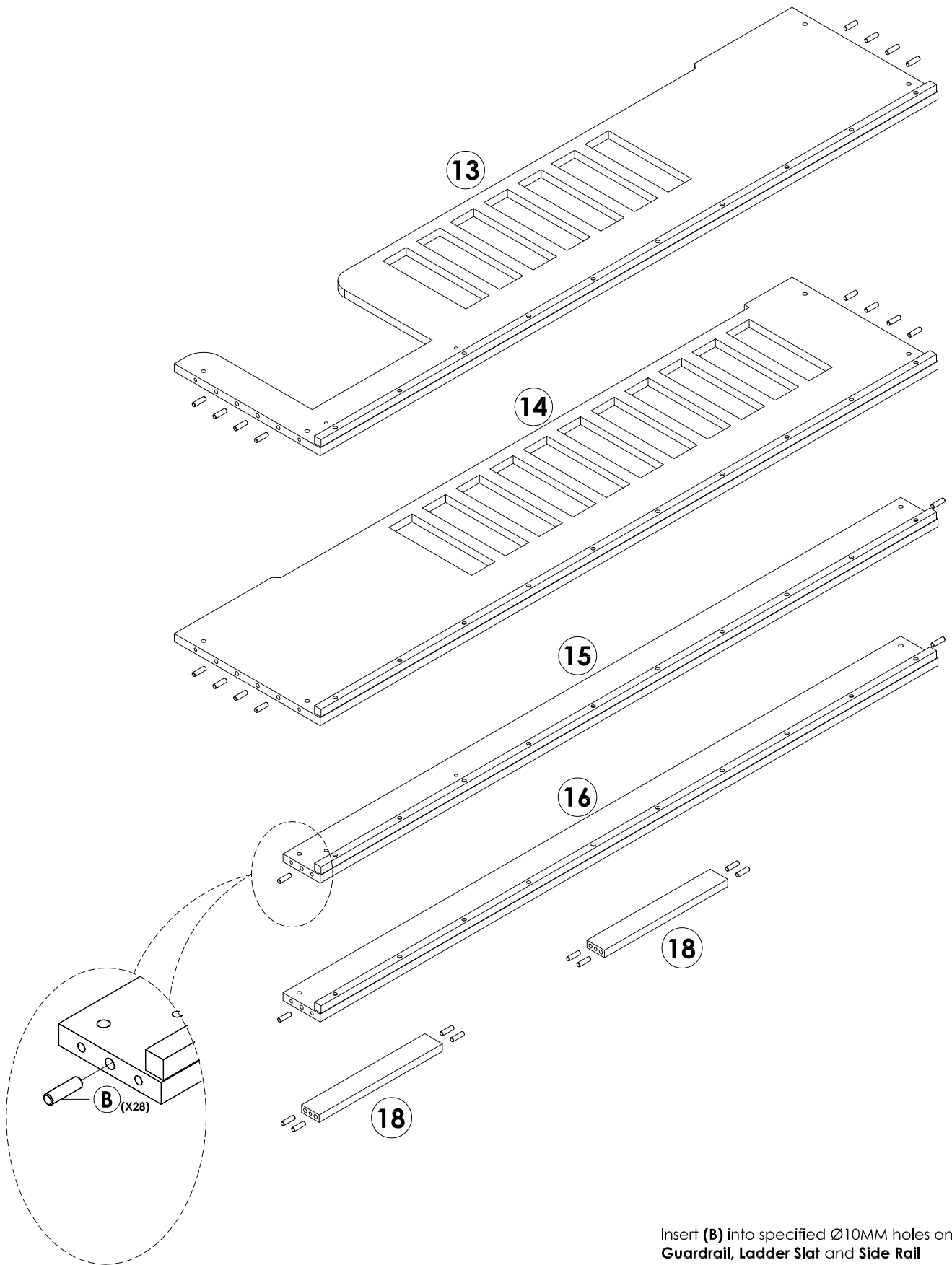

Insert **(B)** into specified $\varnothing 10\text{MM}$ holes on **Guardrail, Ladder Slat and Side Rail (Front/Rear)** by using Rubber Hammer.

How to assemble:

STEP 2

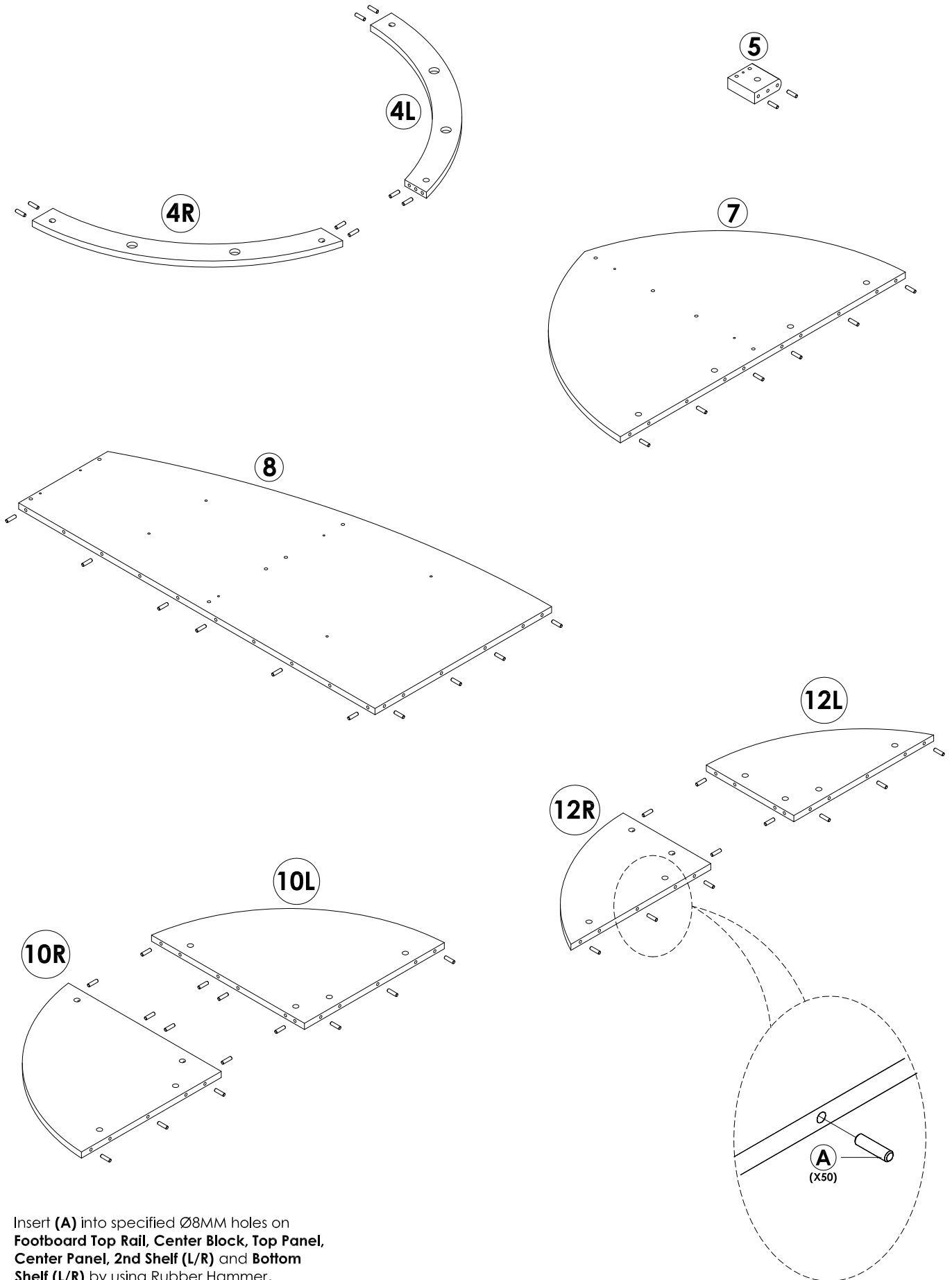

Insert **(A)** into specified Ø8MM holes on **Footboard Top Rail, Center Block, Top Panel, Center Panel, 2nd Shelf (L/R) and Bottom Shelf (L/R)** by using Rubber Hammer.

How to assemble:

STEP 3

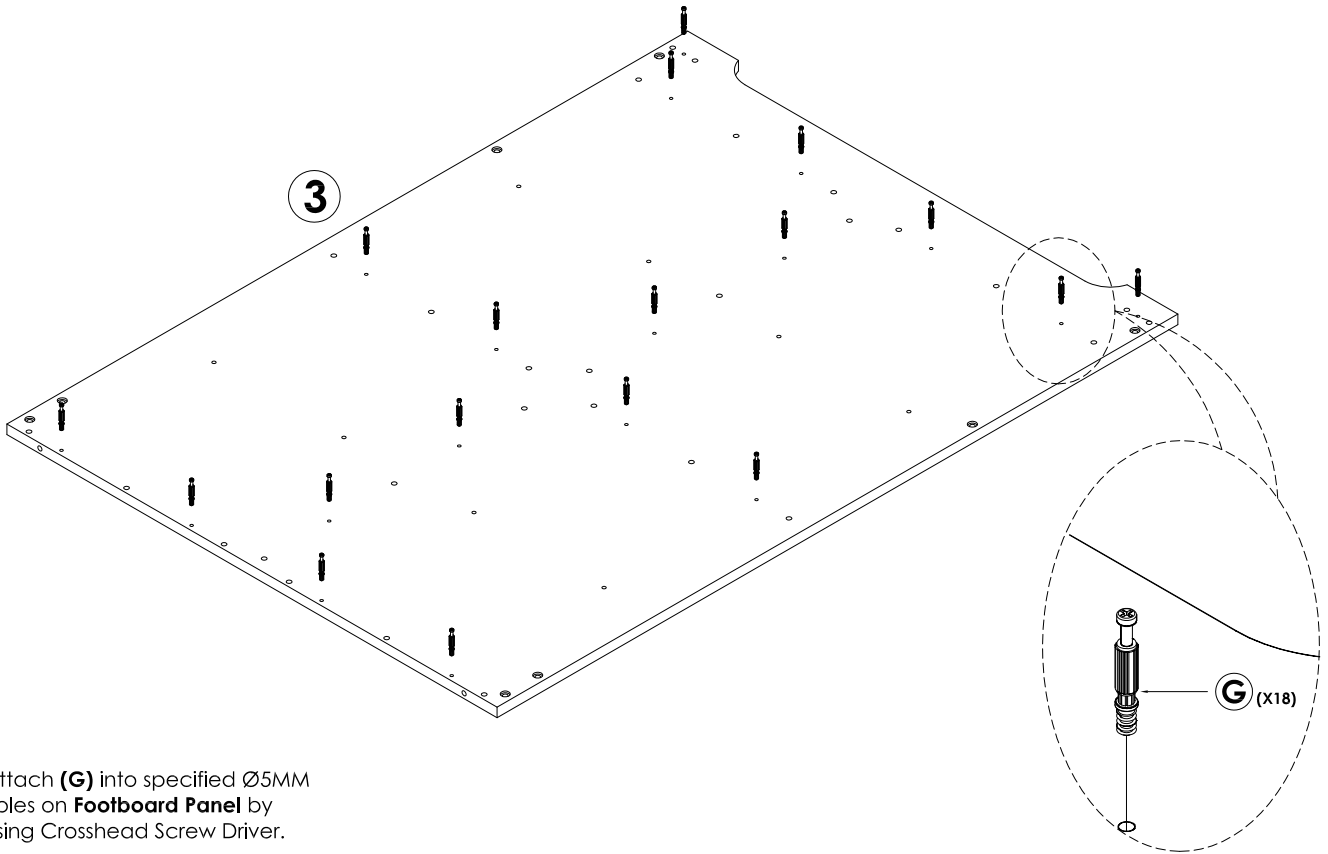

Attach **(G)** into specified $\varnothing 5\text{MM}$ holes on **Footboard Panel** by using Crosshead Screw Driver.

STEP 4

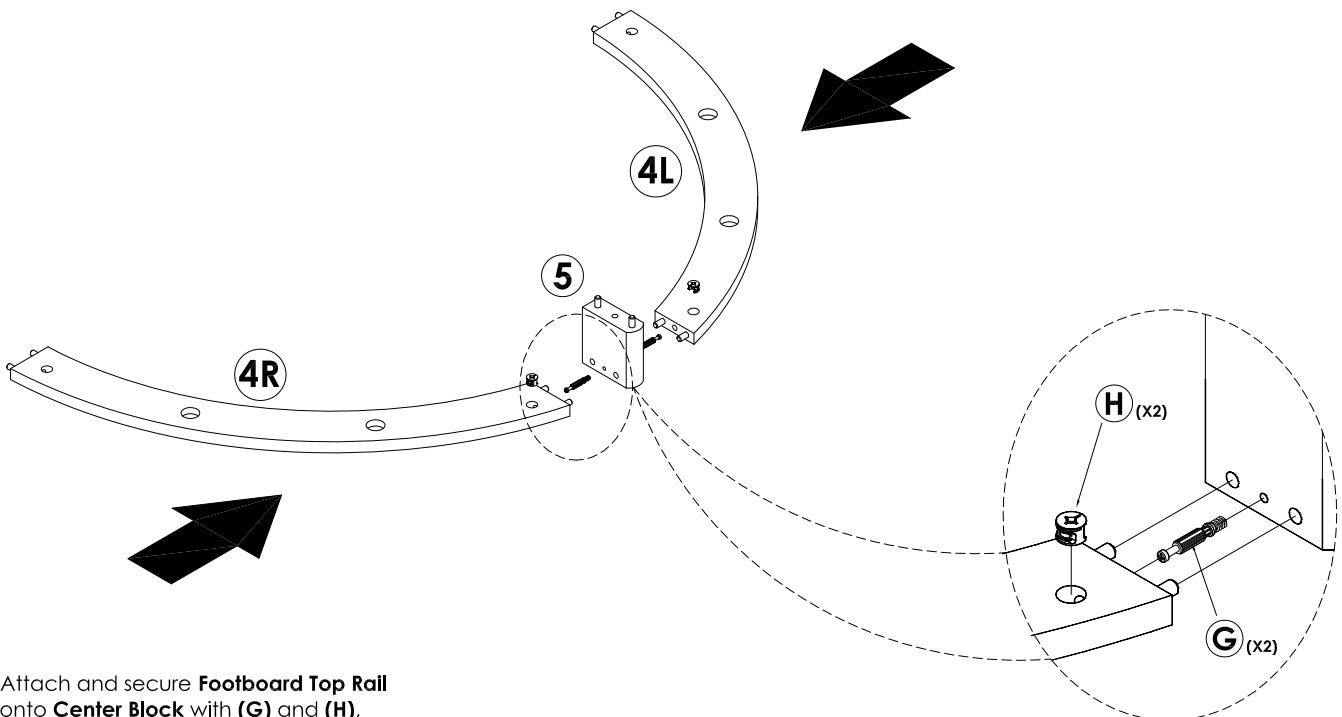

Attach and secure **Footboard Top Rail** onto **Center Block** with **(G)** and **(H)**, tighten it by using Crosshead Screw Driver.

How to assemble:

STEP 5

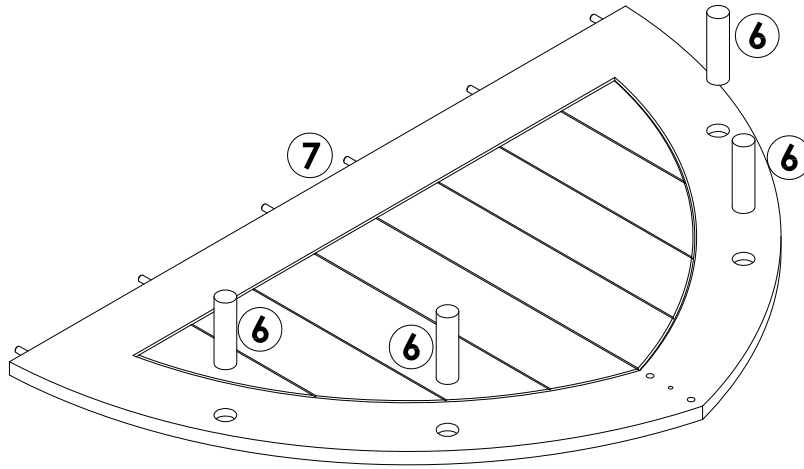

Attach **Round Stick** into specified holes on surface of **Top Panel**.

STEP 6

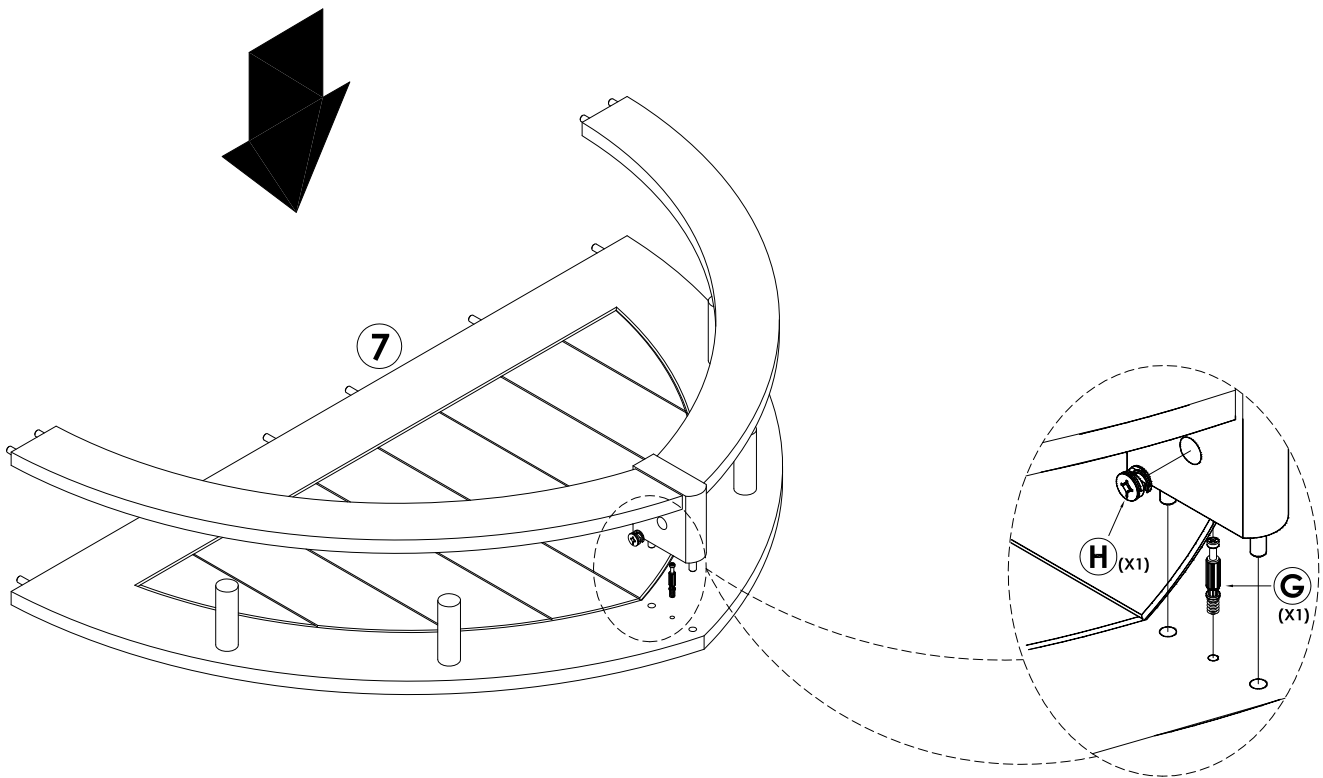

Attach and secure **Center Block** onto **Top Panel** by using **(G)** and **(H)**, tighten it by using Crosshead Screw Driver.

How to assemble:

STEP 7

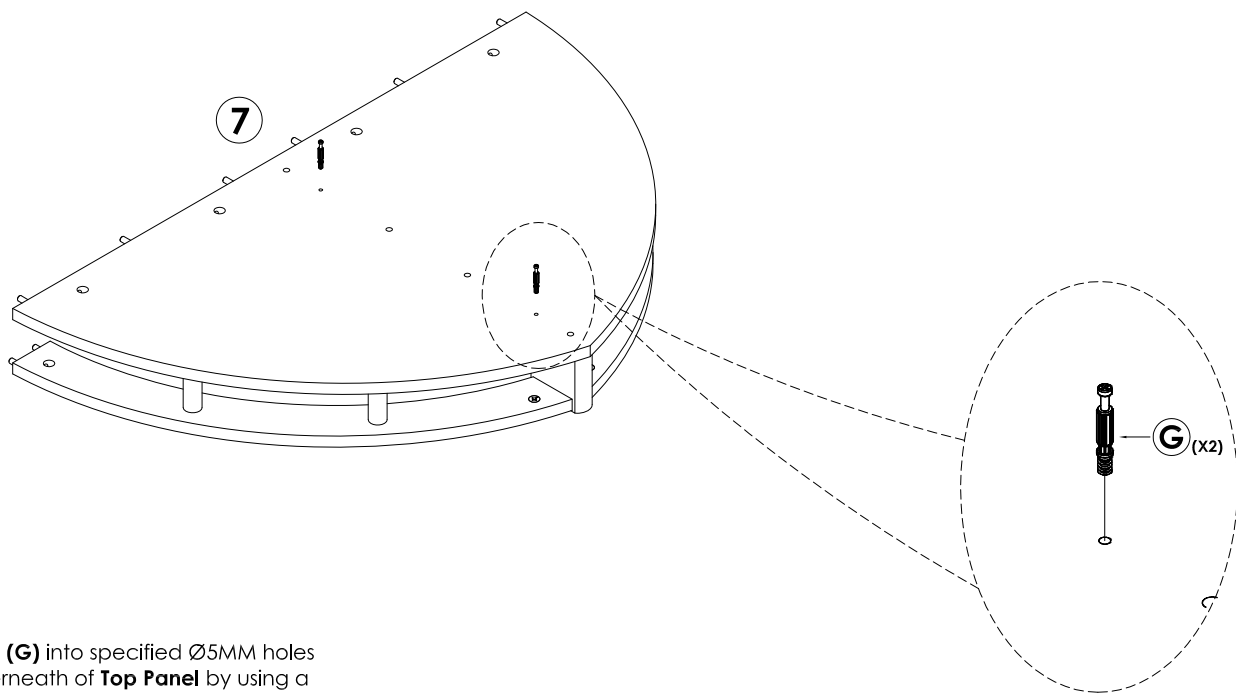

Insert **(G)** into specified $\varnothing 5\text{MM}$ holes underneath of **Top Panel** by using a Crosshead Screw Driver.

STEP 8

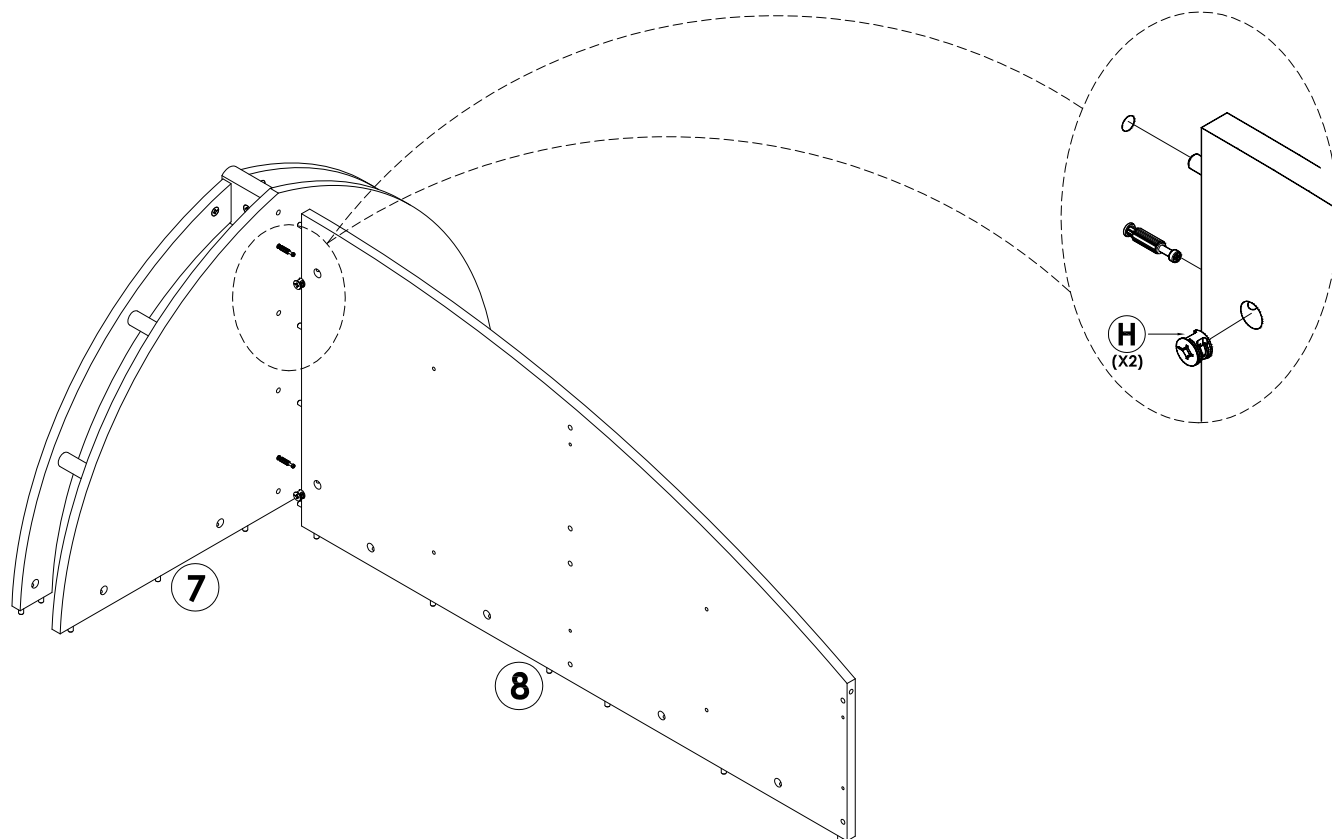

Attach and secure **Center Panel** onto **Top Panel** by using **(H)**, tighten it by using Crosshead Screw Driver.

How to assemble:

STEP 9

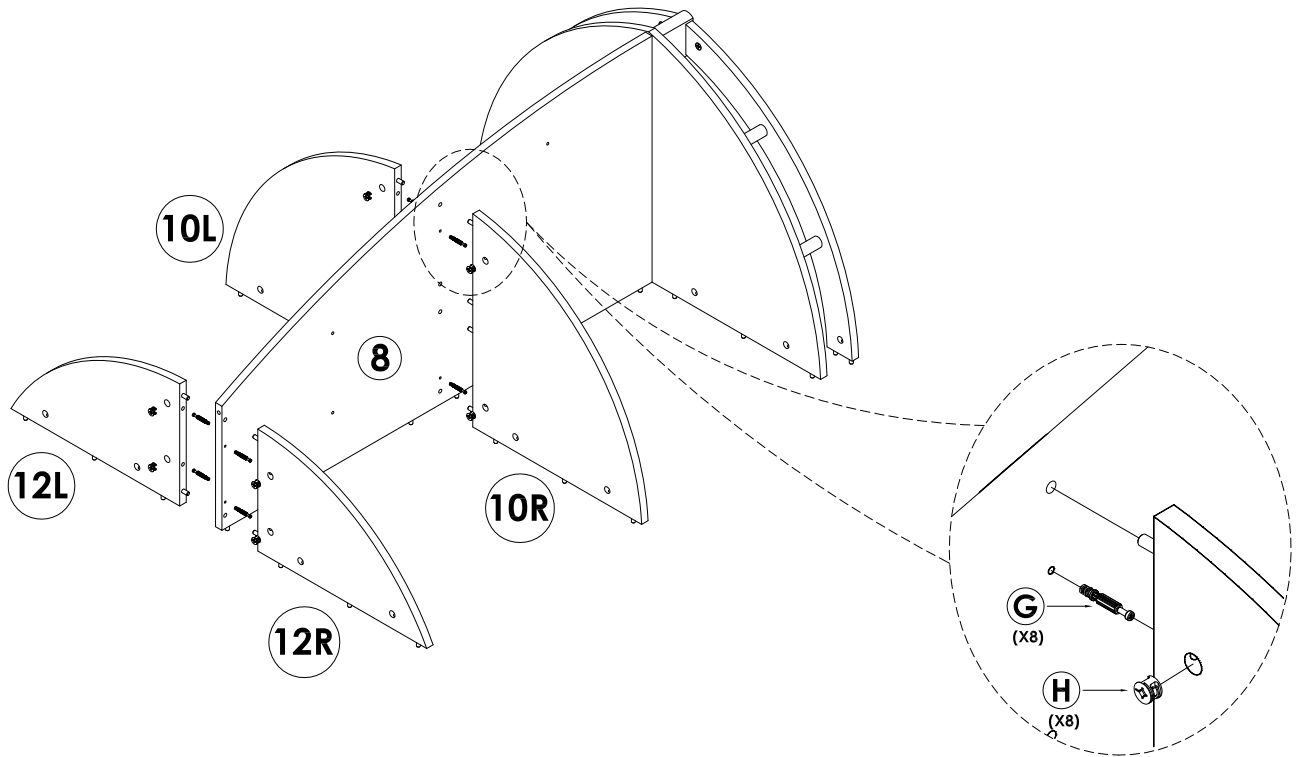

Attach and secure **2nd Shelf (L/R)** and **Bottom Shelf (L/R)** onto **Center Panel** by using **(G)** and **(H)**, tighten it by using Crosshead Screw Driver.

STEP 10

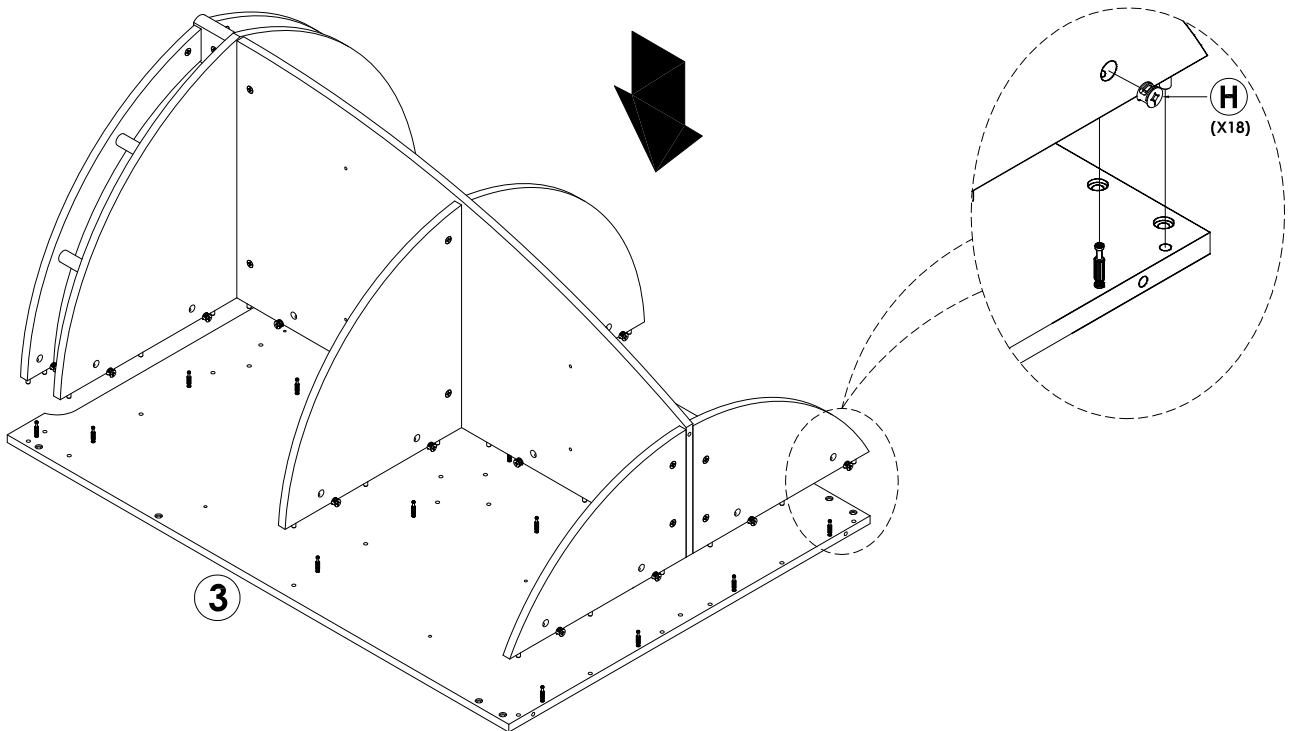

Attach and secure **2nd Shelf (L/R)** and **Bottom Shelf (L/R)** onto **Center Panel** by using **(G)** and **(H)**, tighten it by using Crosshead Screw Driver.

How to assemble:

STEP 11

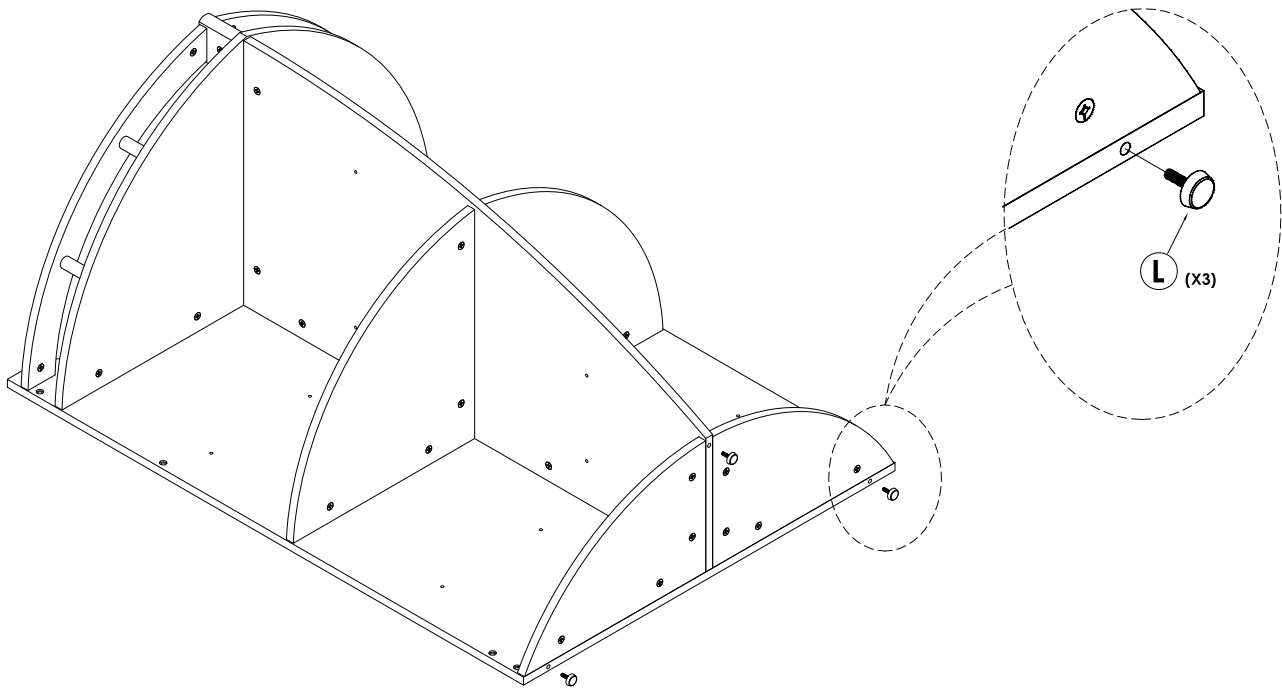

Insert **(L)** into specified holes underneath of previous assembly, adjust **(L)** if the floor is uneven.

STEP 12

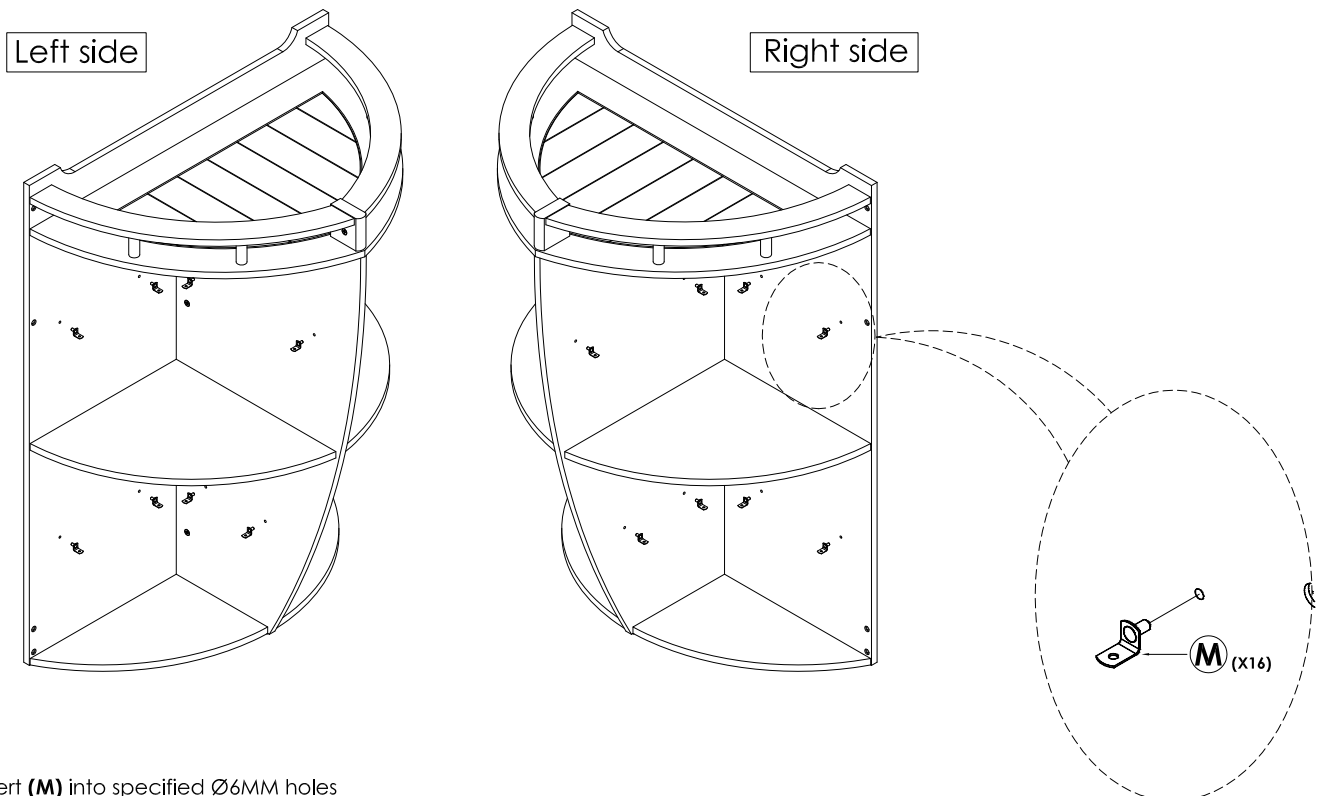

Insert **(M)** into specified $\text{\O}6\text{MM}$ holes on previous assembly.

How to assemble:

STEP 13

Left side

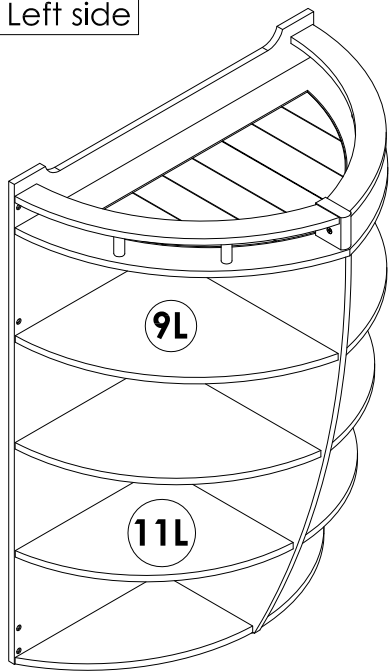

Right side

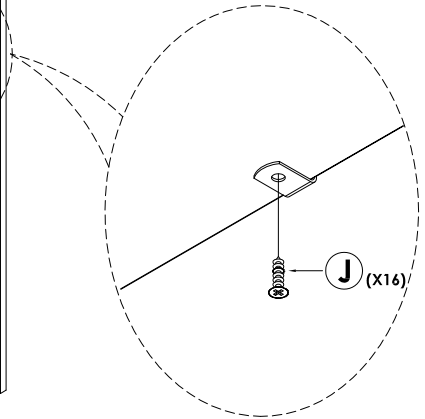
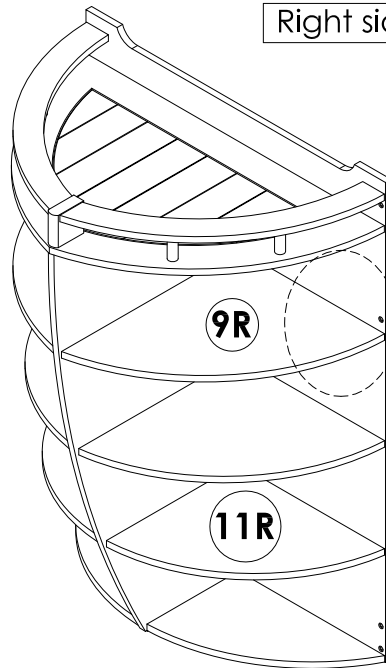

Attach and secure **Top Shelf (L/R)** and **3rd Shelf (L/R)** onto **(M)** by using **(J)**, tighten it by using Crosshead Screw Driver.

STEP 14

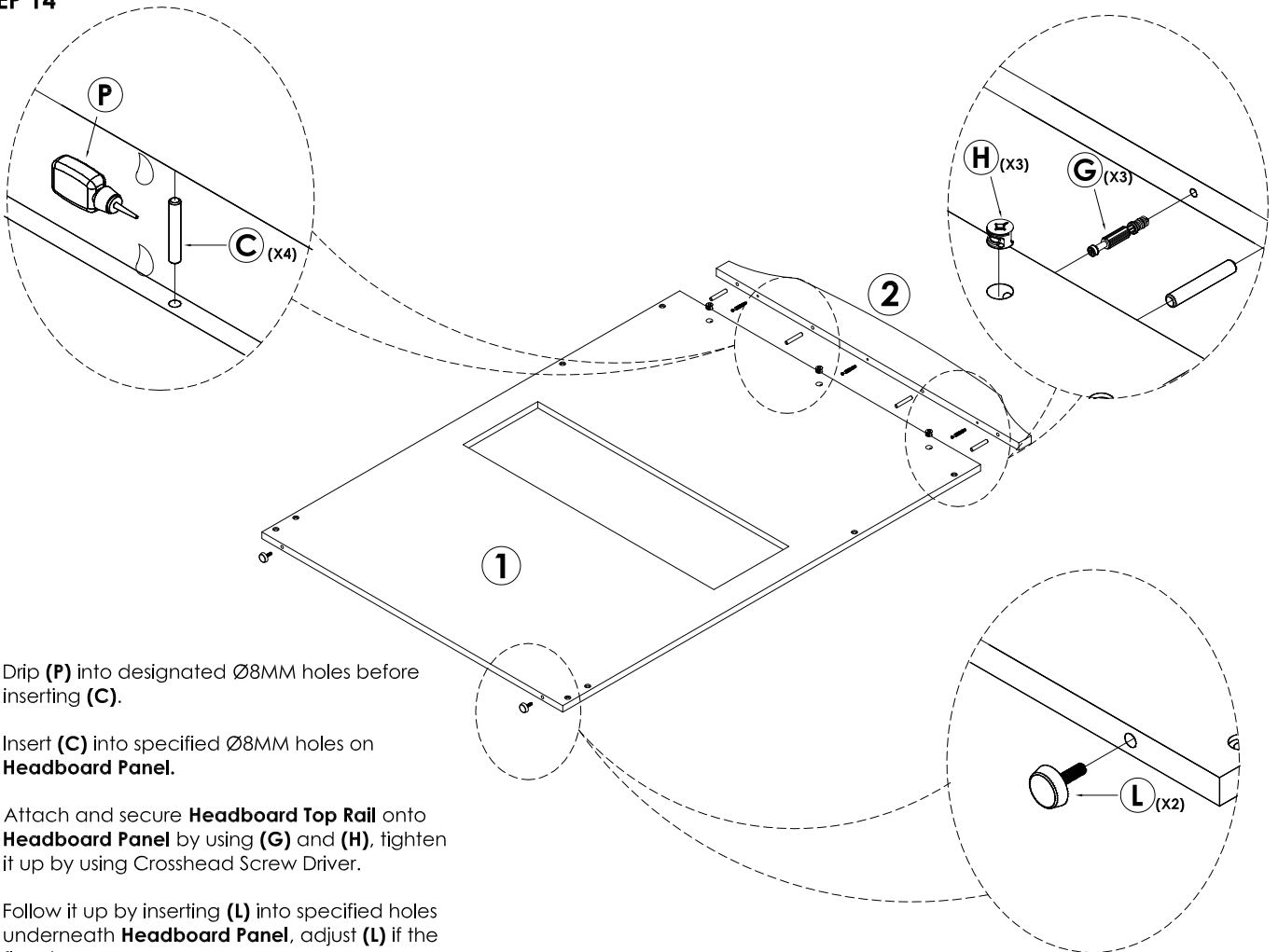

Drip **(P)** into designated Ø8MM holes before inserting **(C)**.

Insert **(C)** into specified Ø8MM holes on **Headboard Panel**.

Attach and secure **Headboard Top Rail** onto **Headboard Panel** by using **(G)** and **(H)**, tighten it up by using Crosshead Screw Driver.

Follow it up by inserting **(L)** into specified holes underneath **Headboard Panel**, adjust **(L)** if the floor is uneven.

How to assemble:

STEP 15

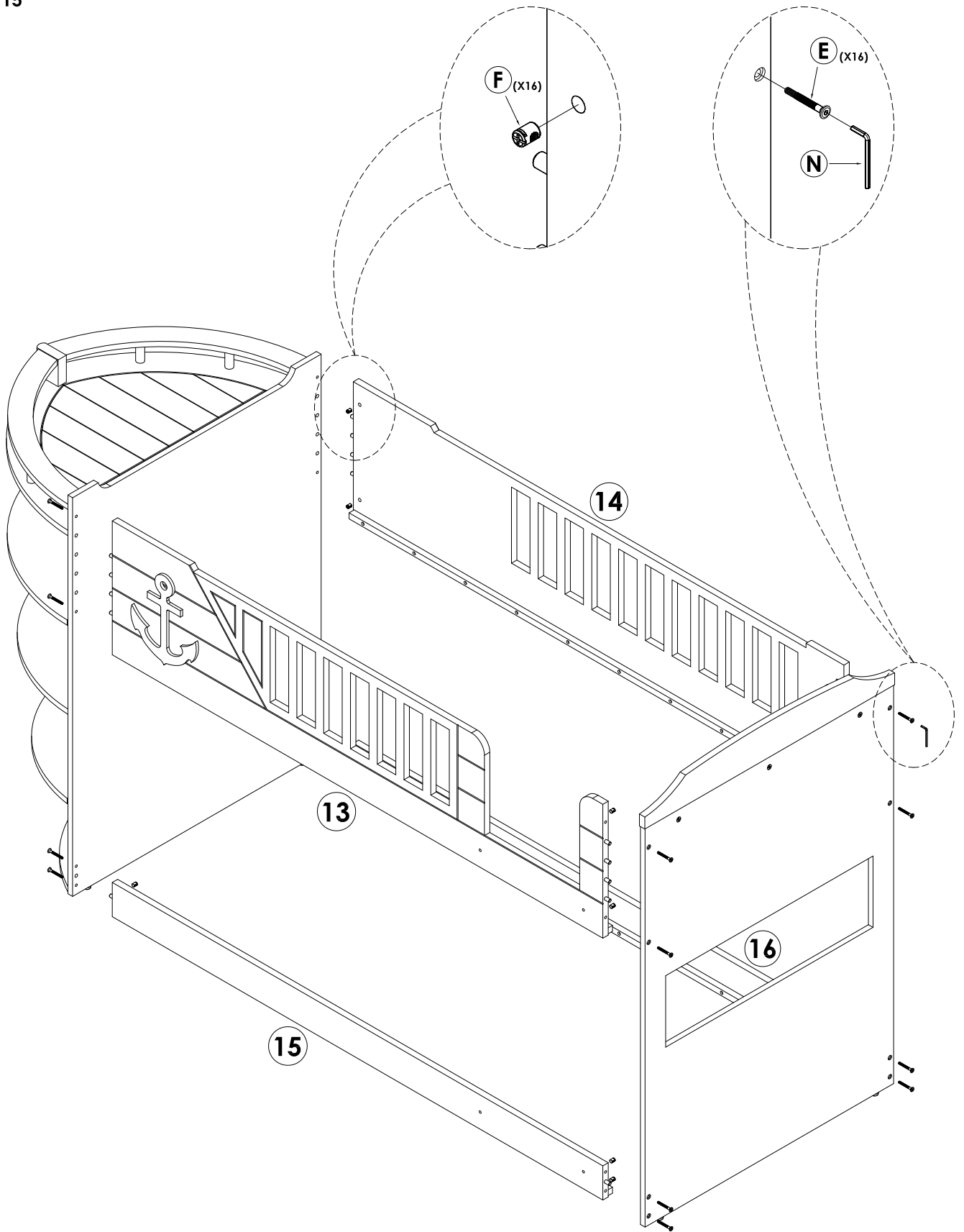

Insert **(F)** into the specified holes $\text{\O}10\text{MM}$ on **Guardrail (Front/Rear)** and **Side Rail (Front/Rear)**. Attach and secure both **Headboard** and **Footboard** assemblies onto **Guardrail (Front/Rear)** and **Side Rail (Front/Rear)** by using **(E)**, tighten it up by using **(N)**.

How to assemble:

STEP 16

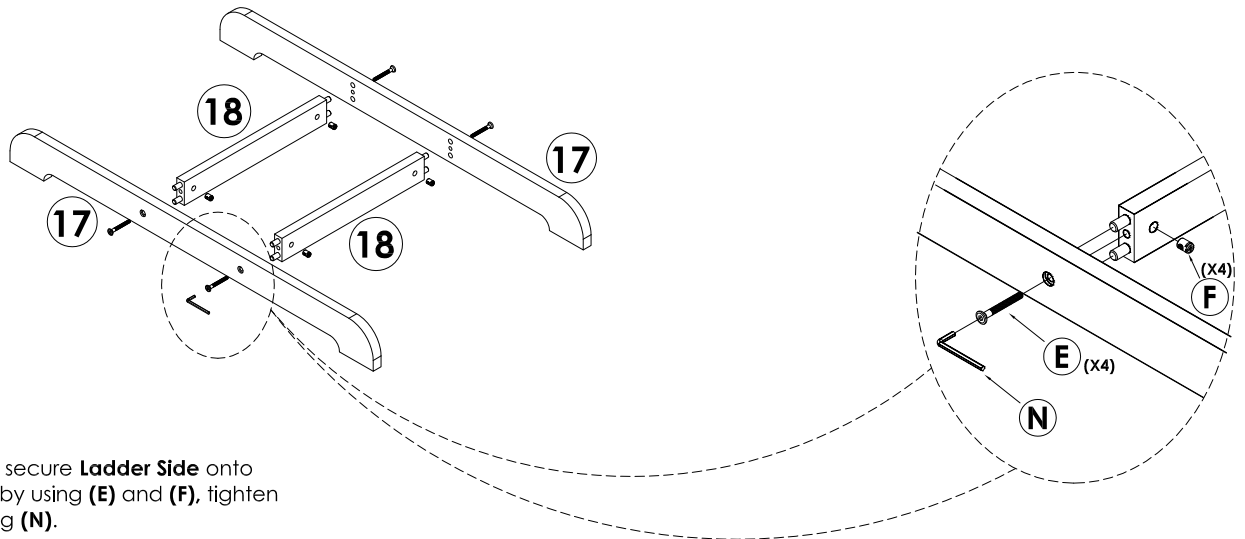

Attach and secure **Ladder Side** onto **Ladder Slat** by using **(E)** and **(F)**, tighten it up by using **(N)**.

STEP 17

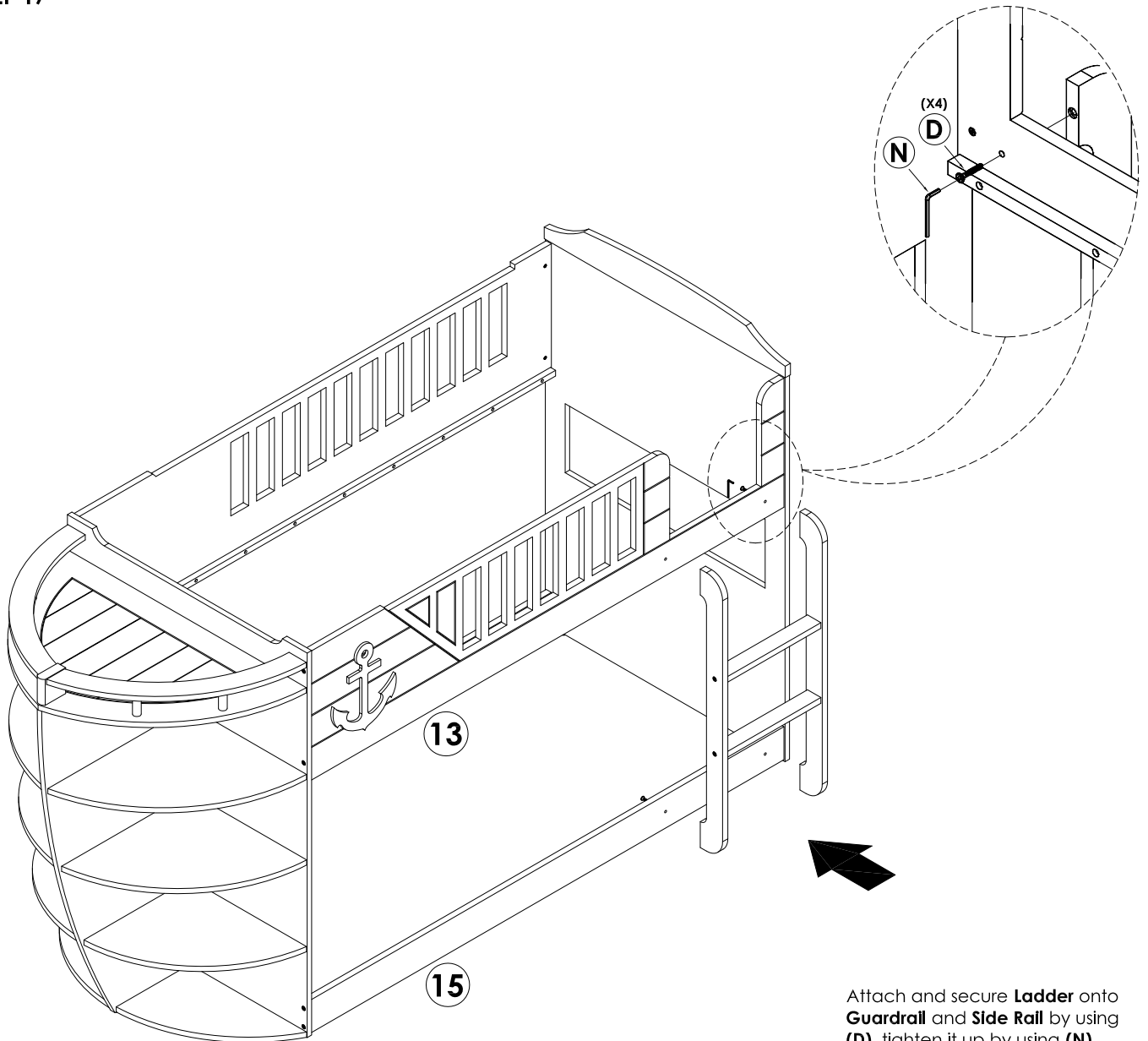

Attach and secure **Ladder** onto **Guardrail** and **Side Rail** by using **(D)**, tighten it up by using **(N)**.

How to assemble:

STEP 18

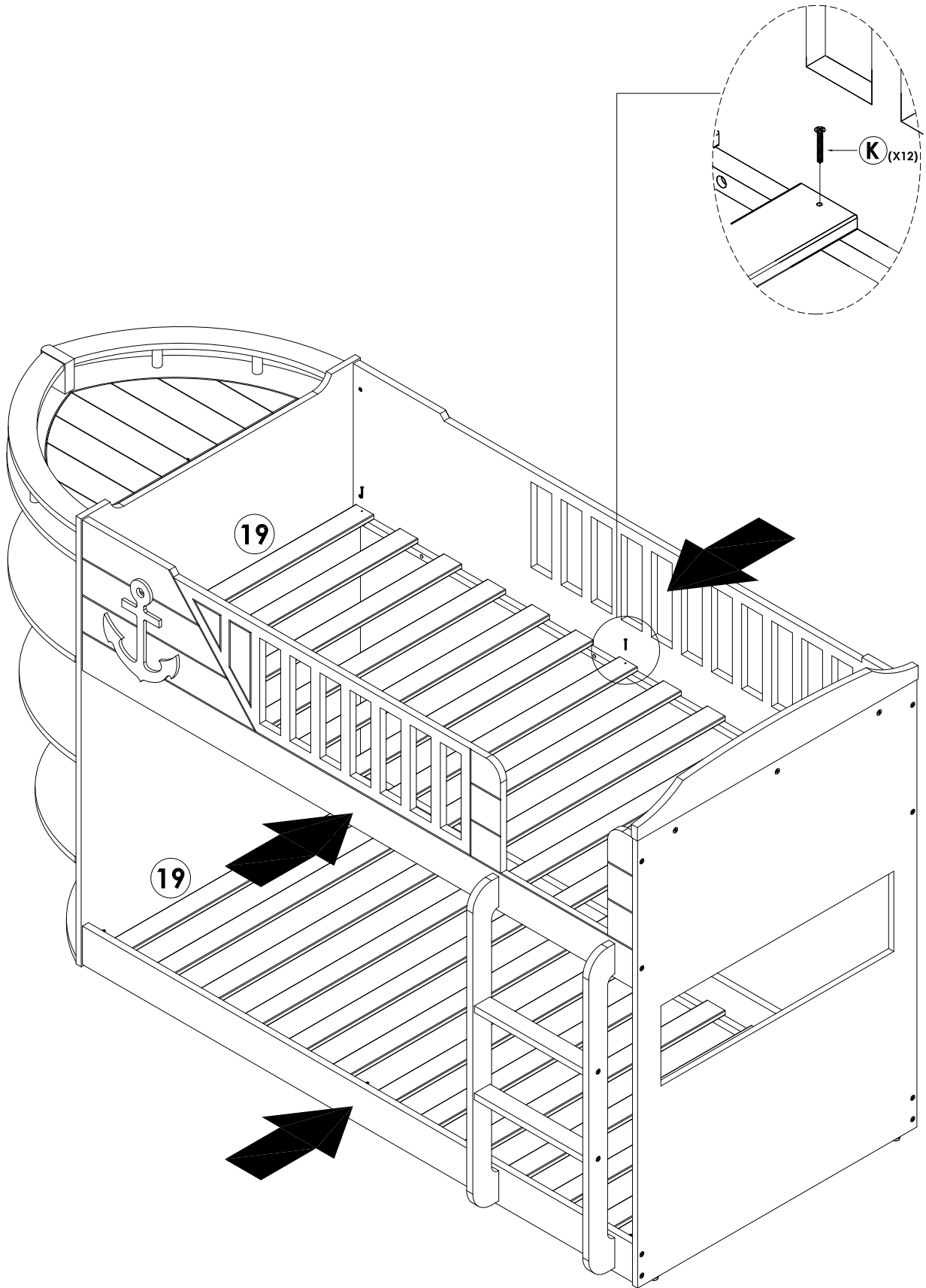

Attach and secure **Wooden Slat** onto slat supports by using **(K)**, tighten it up by using a Crosshead Screw Driver. Go on to complete the entire assembly.

Align both **Side Rail (Front/Rear)** and **Guardrail (Front/Rear)** before tightening the screws.