

ASSEMBLY INSTRUCTION FOR ACME FURNITURE

MODEL#OF00005-1/OF00005-2/OF00006-1/OF00006-2

Thank you for purchasing the quality product. Be sure to check all packing material carefully for small parts which may have come loose inside the carton during shipment. Separate, identify and count all parts and metal hardware. Compare with all parts list to be sure all parts are present. If any part(s) are missing or damaged, please contact your local furniture dealer. For efficient and speedy service, please indicate the model number and code letter of part(s) needed.

*****Do not fully tighten screws until fully assembled*****

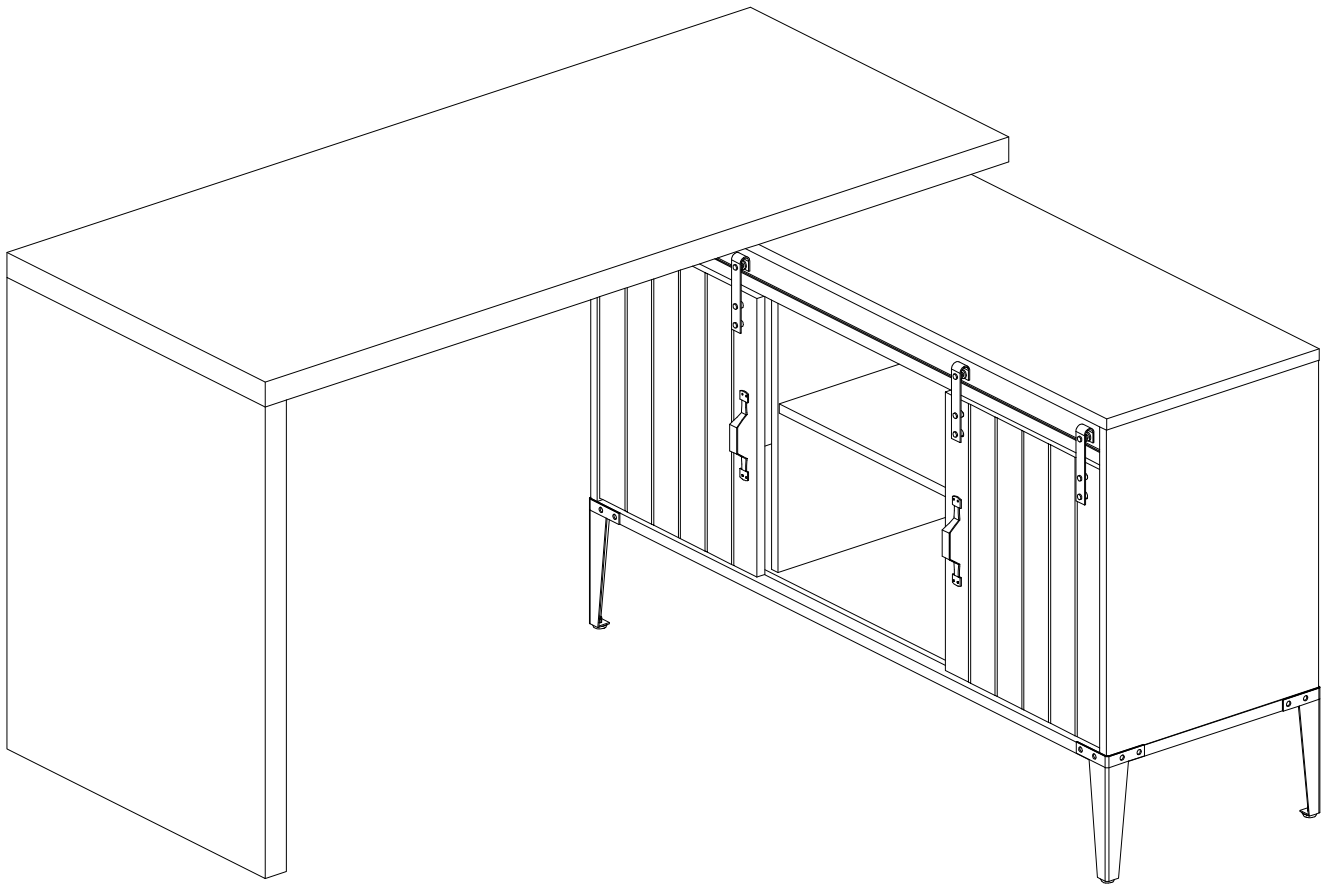

Attention:

***Some number parts listed on the instruction sheet may not be in parts bag as they may already be assembled. Carefully check parts and packing materials prior to ordering replacements.

General Assembly Guidelines

- I. Ensure that all parts and hardware are available before beginning assembly.
- II. Follow each step carefully to ensure the proper assembly of this product.
- III. Two people are recommended for ease in the assembly of this product.
- IV. The three main types of hardware used to assemble this product are : wood dowels , screws and bolts.
- V. The provided glue is to secure wood dowels in place . When first inserting dowels , locate the appropriate hole for the dowel , place a small amount of glue in the hole and insert the dowel . Wipe away excess glue immediately.

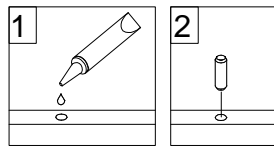

In future assembly steps when dowels are necessary to attach assembly parts together , place a small amount of glue on the end of the dowel before attaching parts together . Wipe away excess glue immediately.

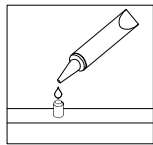

- VI. A Phillips head screwdriver is required for the assembly of this product .

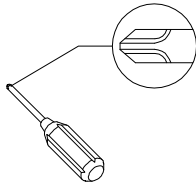



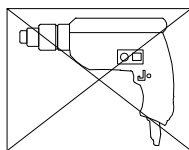



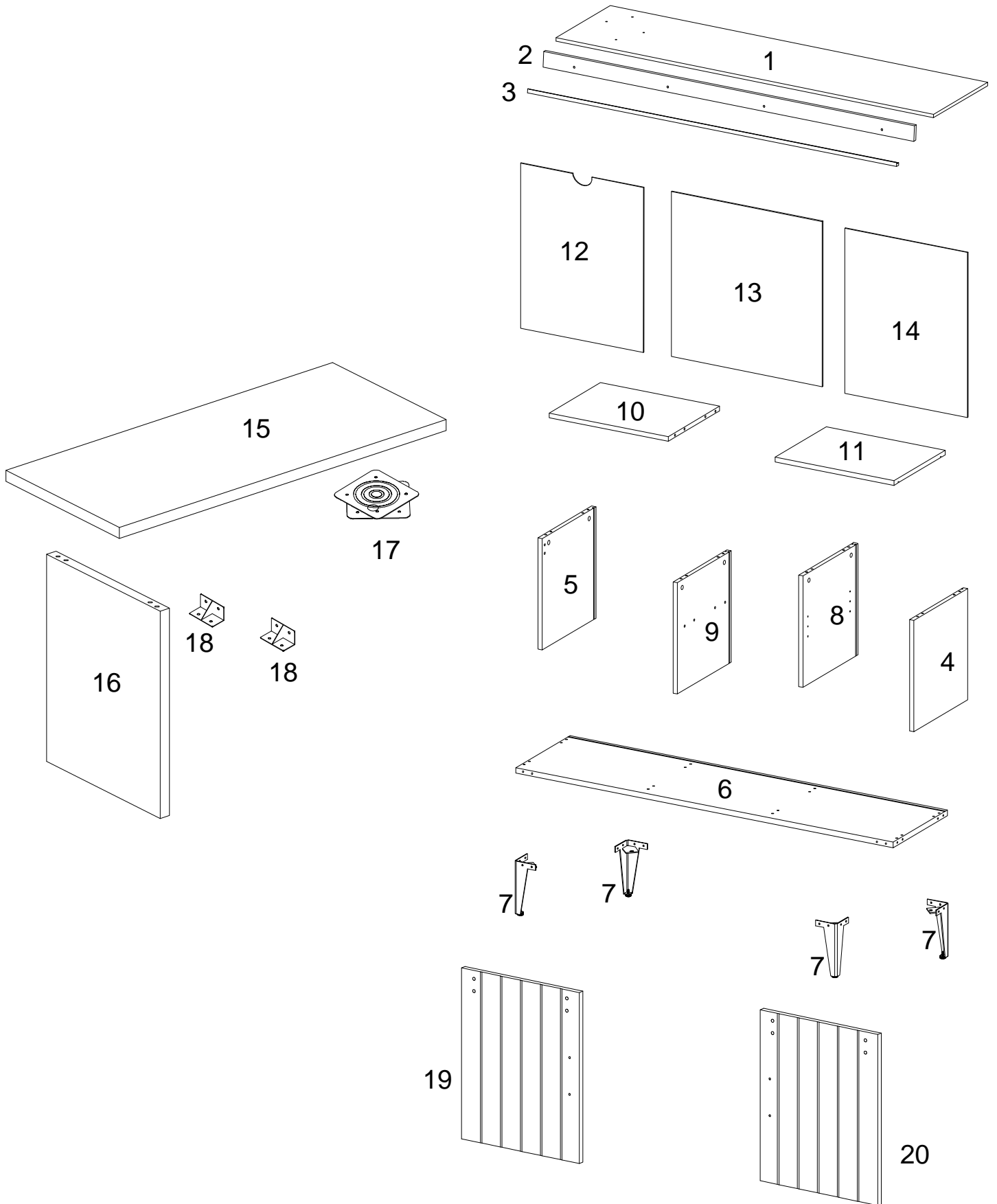





- VII. Power tools should not be used to assemble this product .







Parts List



Hardware List



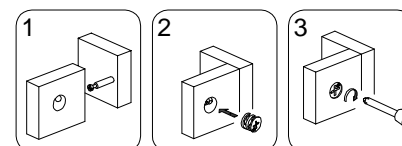
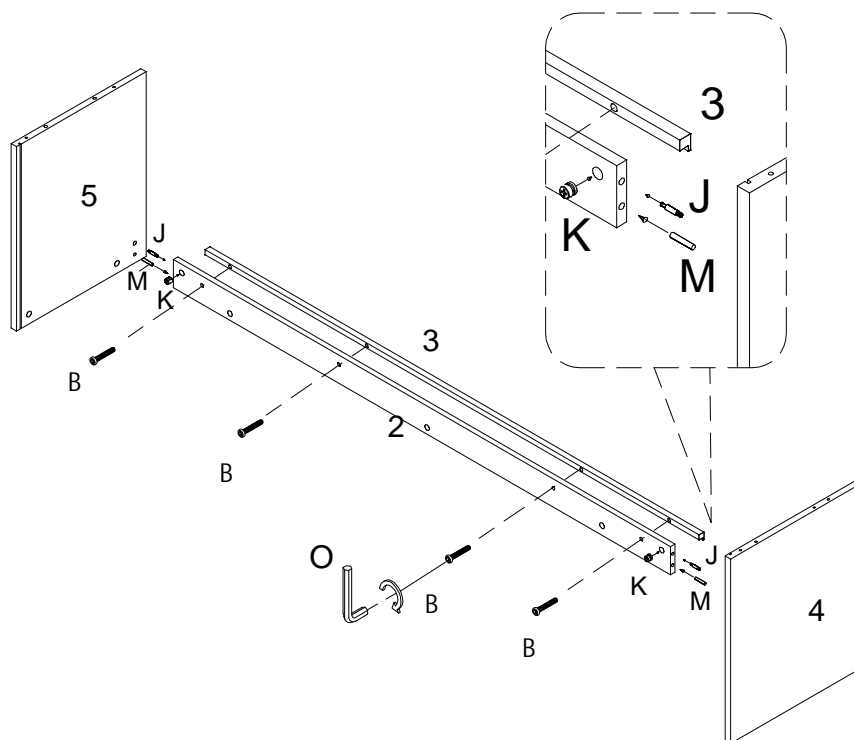

A		Ø1/4"x12mm	Bolt	20 pcs	O		M4mm	Hex Key	1 pcs
B		Ø1/4"x25mm	Bolt	4 pcs	P			Glue tube	1 pcs
C		Ø1/4"x12mm	Bolt	8 pcs	Q		M5mm	Hex Key	1 pcs
D		Ø3.5x16mm	Screw	12 pcs	R			Hanging wheel	4 pcs
E			Corner code	2 pcs	S			Positioning iron	4 pcs
F		Ø4x18mm	Screw	4 pcs	T			Handle	2 pcs
G			Plastic wedge	12 pcs	U		M 8X30mm	Bolt	4 pcs
H		Ø3x17mm	Screw	12 pcs	V		M 8X20mm	Bolt	12 pcs
I			Shelf support pin	4 pcs	W		M8mm	Nut	6 pcs
J		Ø6x35mm	Cam bolt	17 pcs	X			Wrench	1 pcs
K		Ø15x11mm	Cam lock	17 pcs	Y		M8mm	Washer	14 pcs
L			Sticker	17 pcs	Z		M8X775mm	Screw rod	2 pcs
M		Ø8x30mm	Wooden dowel	24 pcs	a			Sleeve	1 pcs
N		Ø6x50mm	Screw	8 pcs	b		M8mm	Washer	12 pcs

Step 1

B x 4  Ø1/4"x25mm	J x 2  Ø6x35mm	K x 2  Ø15x11mm	M x 2  Ø8x30mm	O x 1  M4mm
---	---	---	--	---



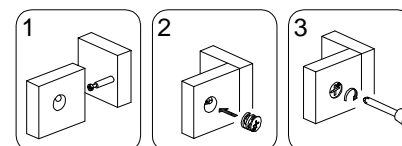
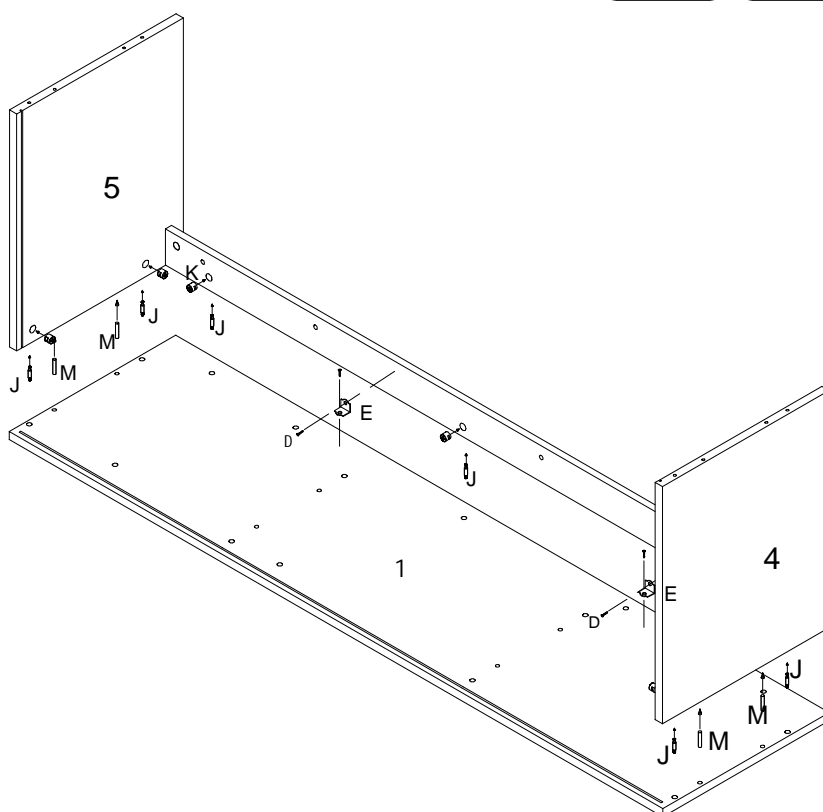

Step 2

D x 4  Ø3.5x16mm	E x 2 	J x 7  Ø6x35mm	K x 7  Ø15x11mm	M x 4  Ø8x30mm
--	---	--	---	--



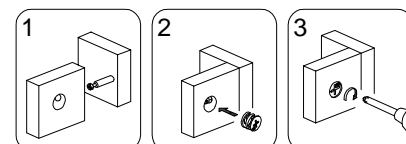
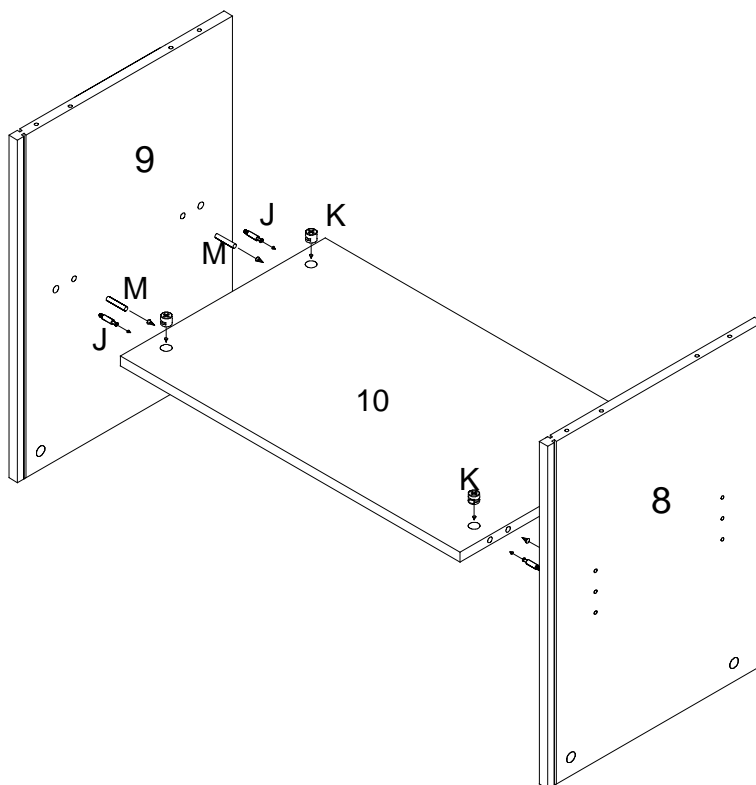

Step 3

J x 4	K x 4	M x 4
		
Ø6x35mm	Ø15x11mm	Ø8x30mm



Step 4

J x 4	K x 4	M x 4
		
Ø6x35mm	Ø15x11mm	Ø8x30mm

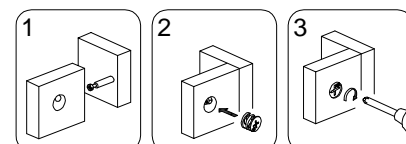
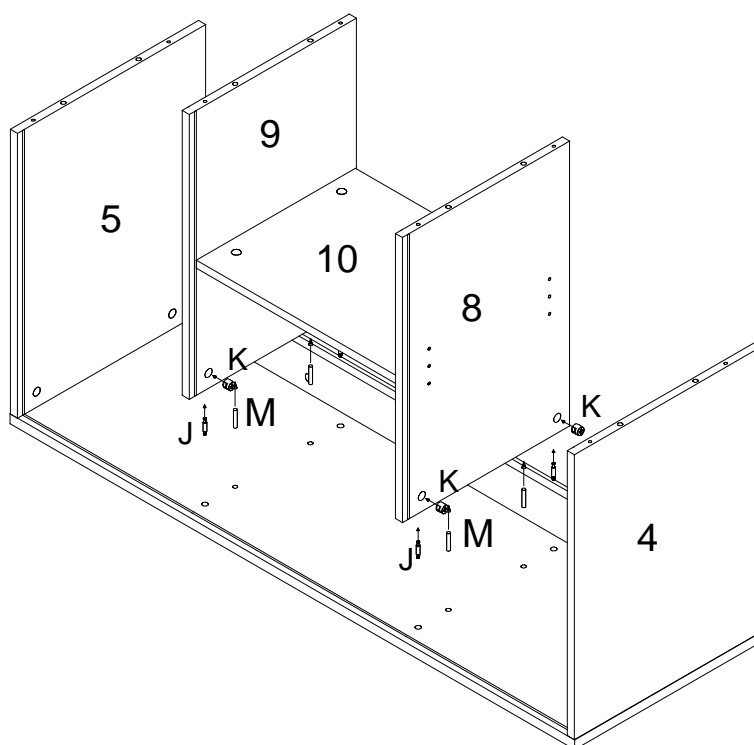

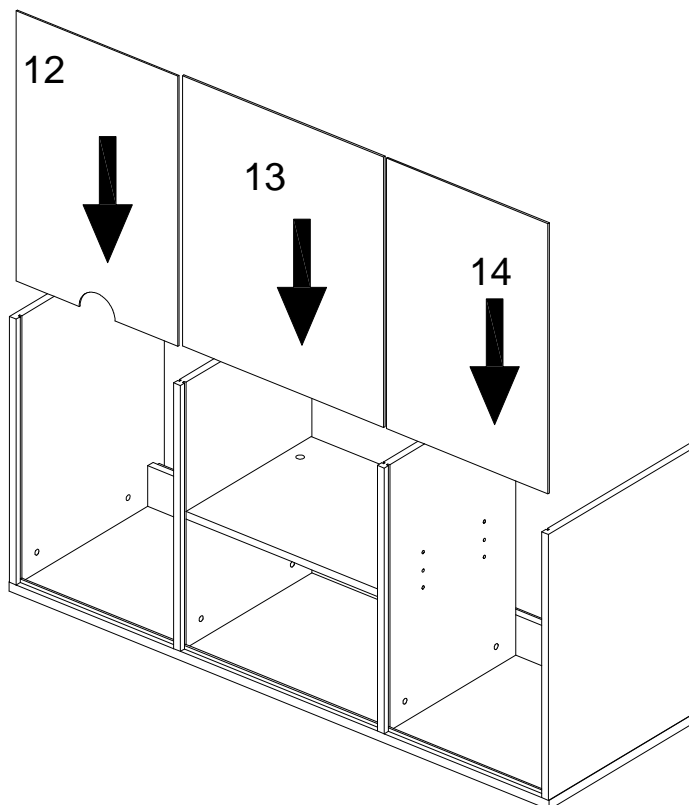

Step 5



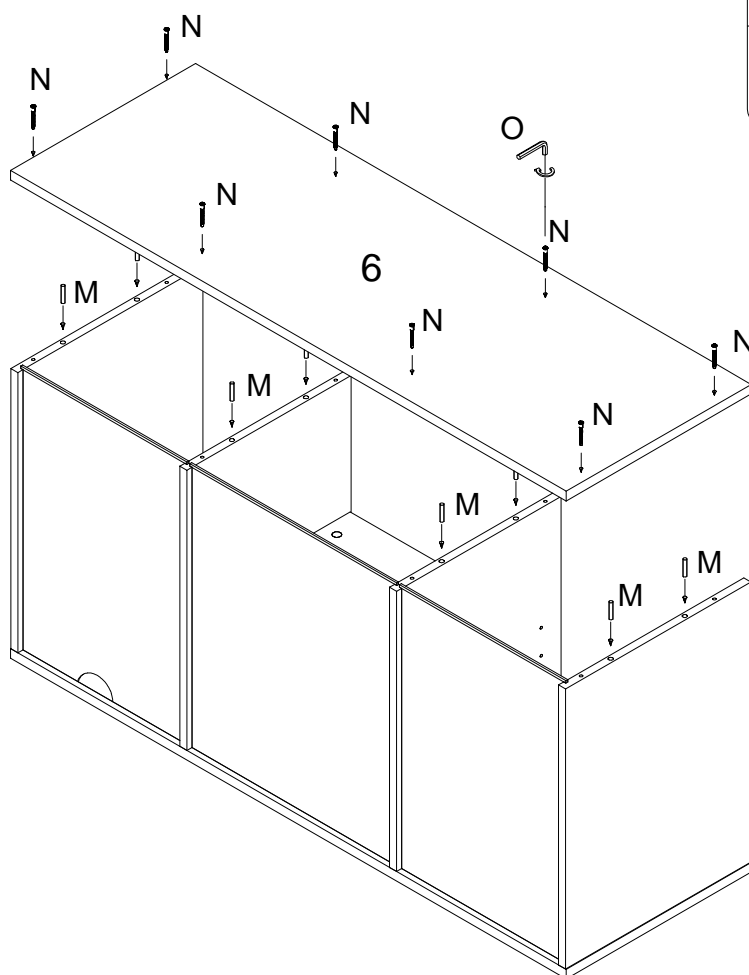

Step 6





M x 8  Ø8x30mm	N x 8  Ø6x50mm	O x 1  M4mm
---	---	--

Step 7

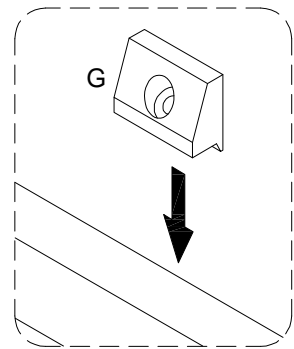
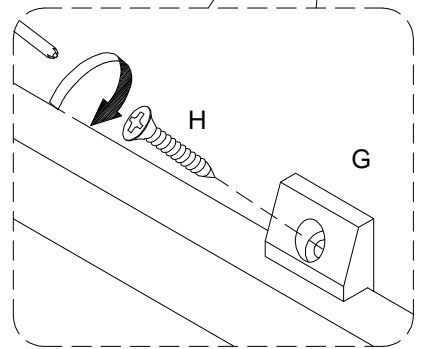
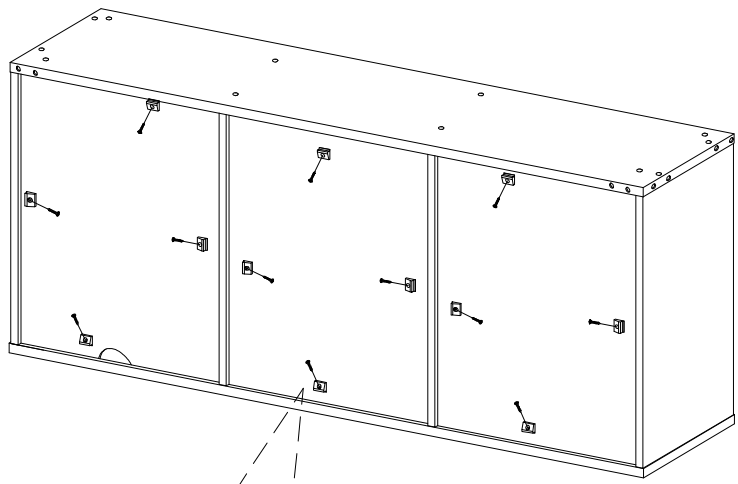
G x 12	H x 12
	
	Ø3x17mm



Step 8

A x 20	O x 1
	
Ø1/4"x12mm	

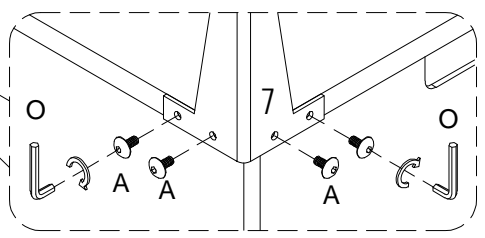
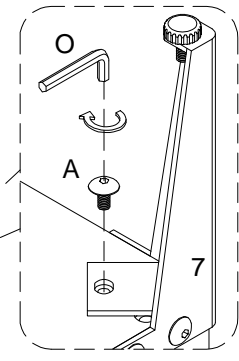
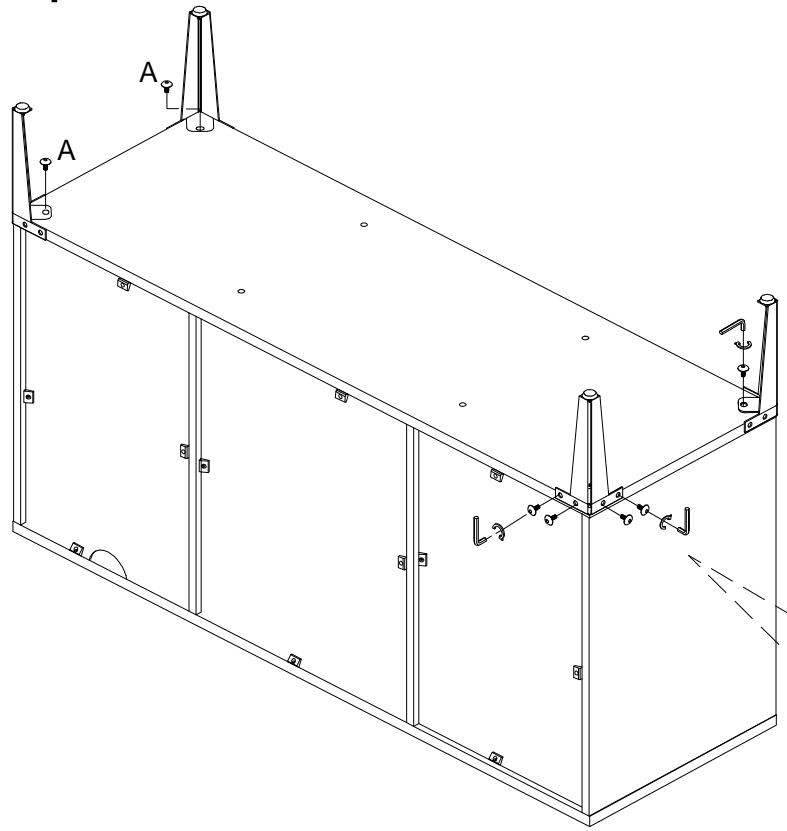

Step 9

L x 17

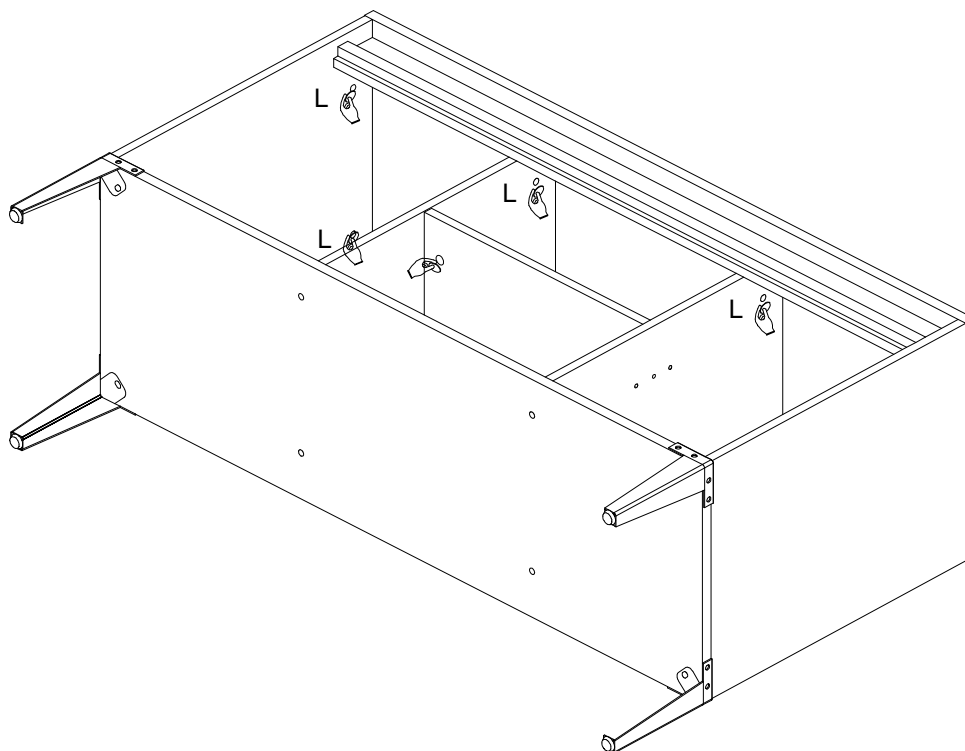

Step 10

I x 4

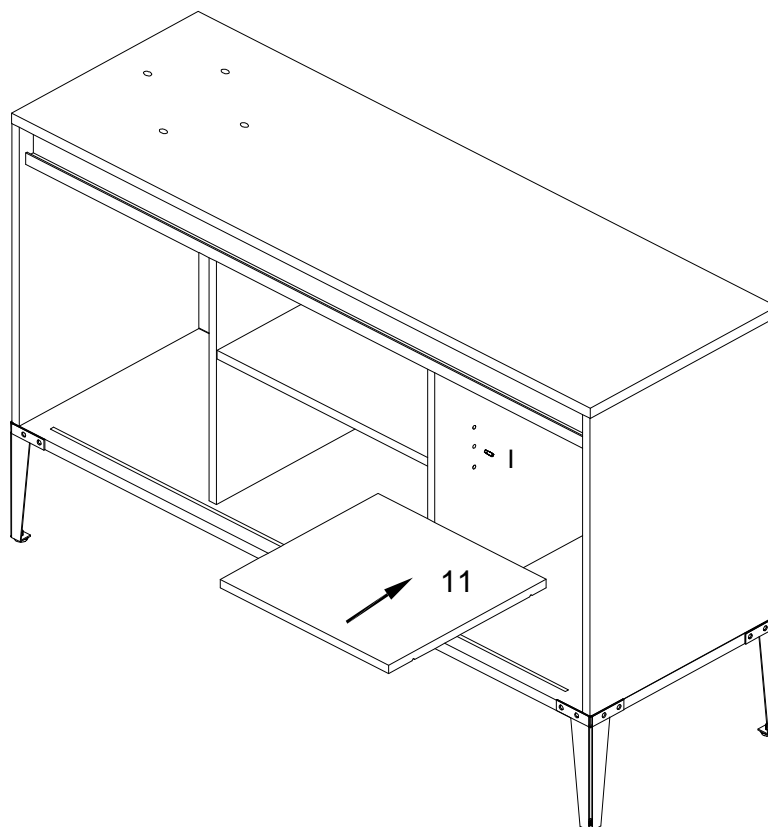



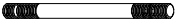

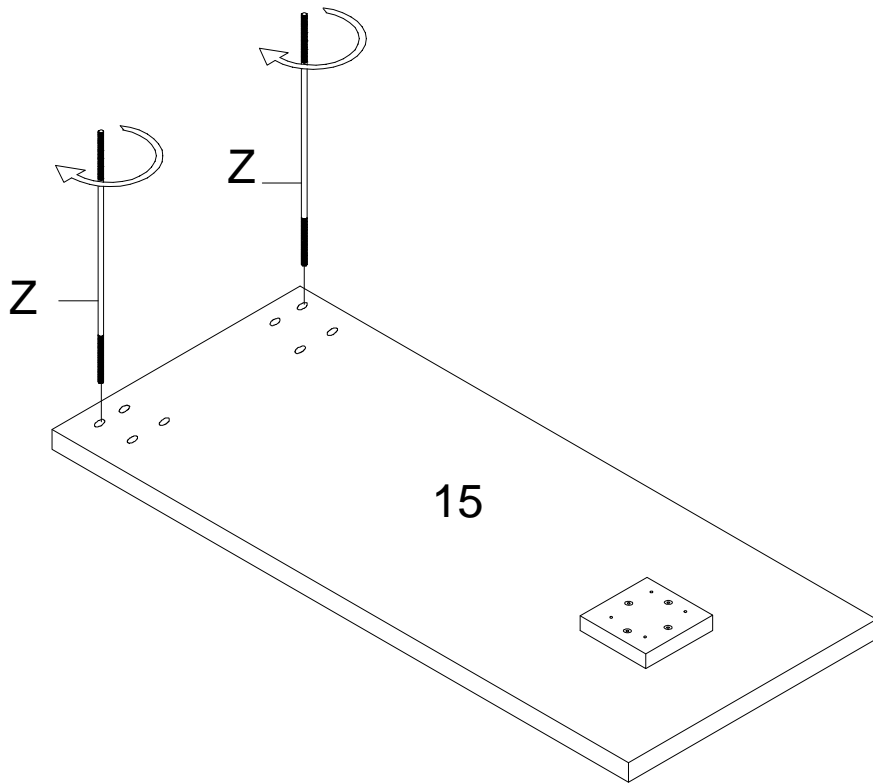
Step 11

Z	x	2
		
M 8X775mm		





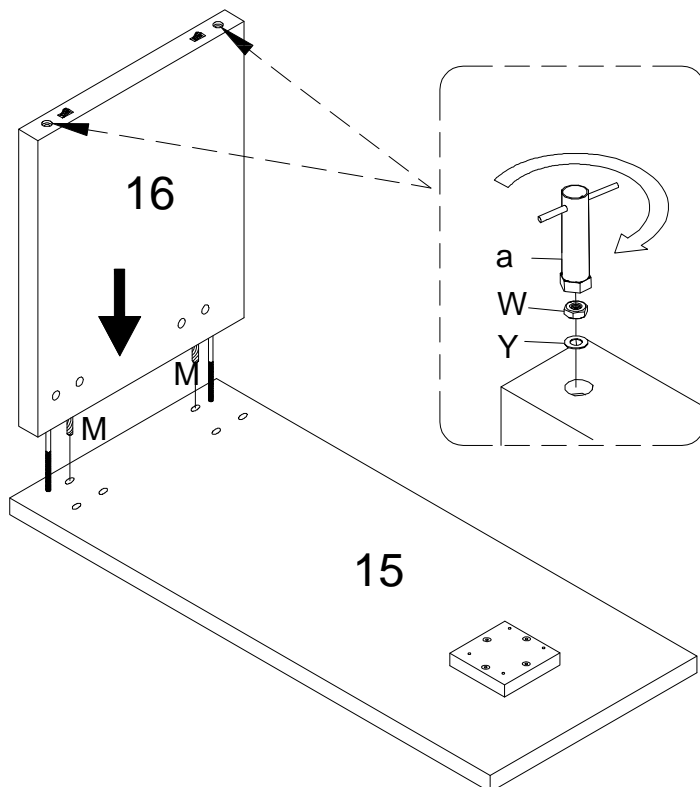

Step 12

M x 2	W x 2	Y x 2	a x 1
			
Ø8x30mm	M8	M8	







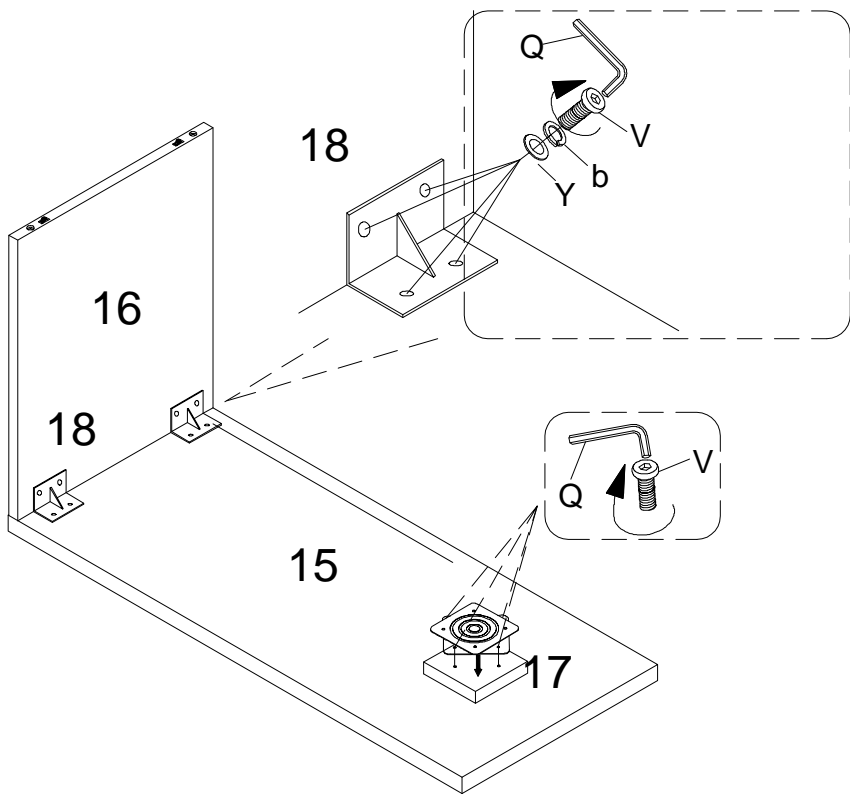

Step 13

Q x 1	V x 12	Y x 8	b x 8
			
M5mm	M 8X20mm	M8mm	M8mm







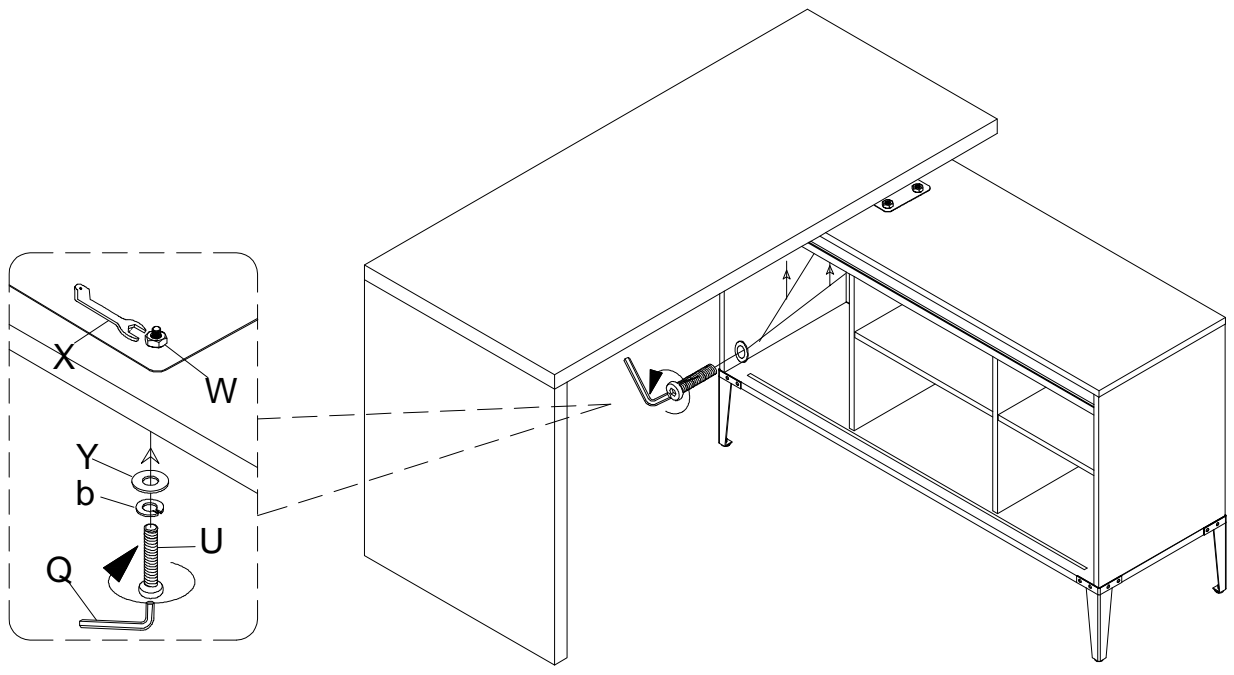

Step 14

Q x 1	U x 4	W x 4	X x 1	Y x 4	b x 4
					
M5mm	M 8X30mm	M8		M8mm	M8mm



Step 15

C x 8  Ø1/4"x12mm	F x 4  Ø4x18mm	D x 8  Ø3.5x16mm	R x 4 	S x 4 	T x 2 
--	---	---	--	--	--

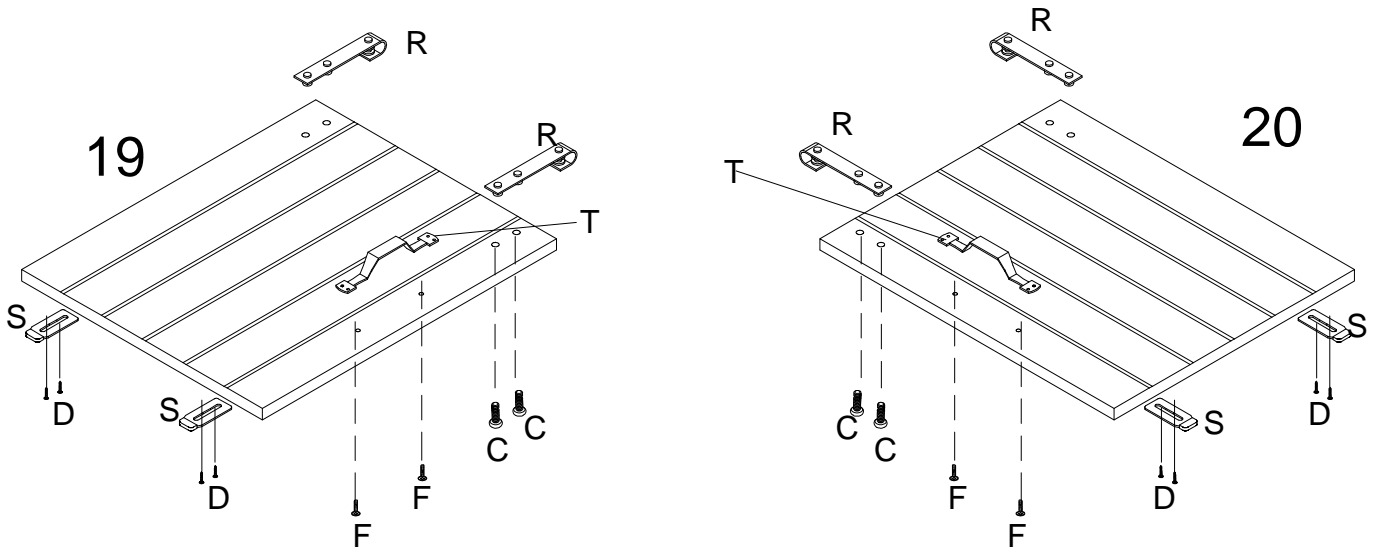

Step 16

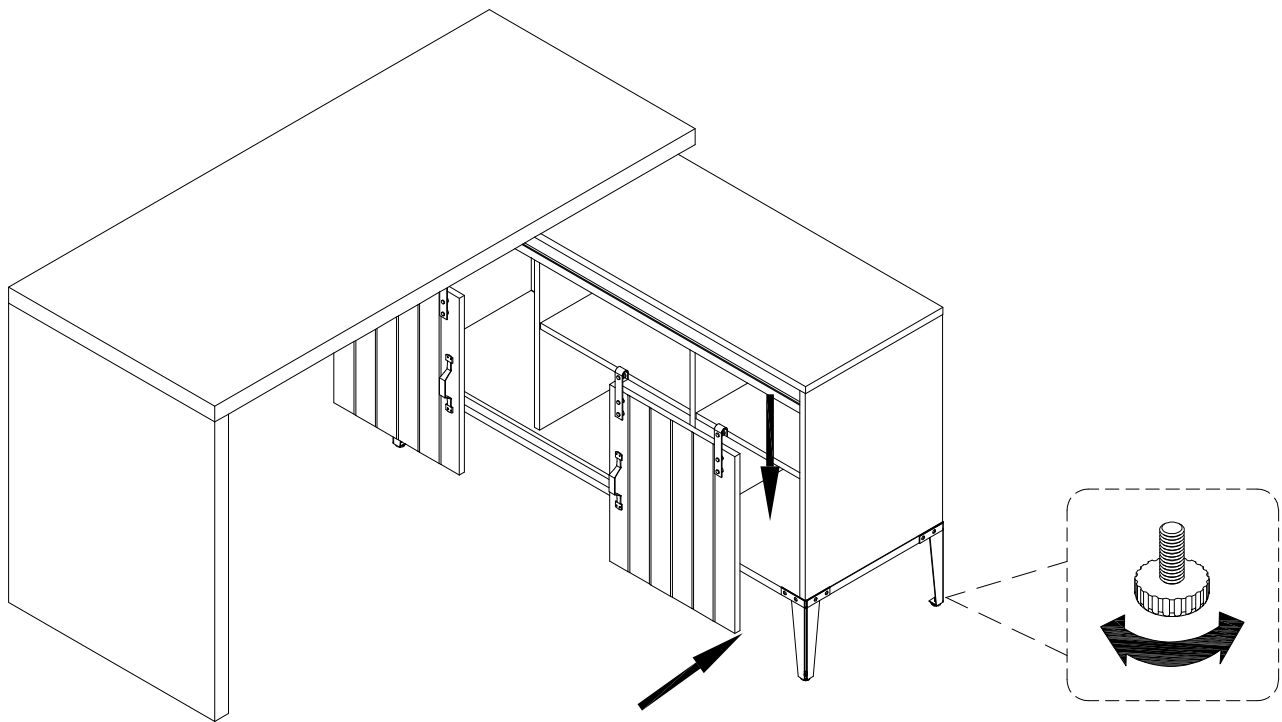

Step 17

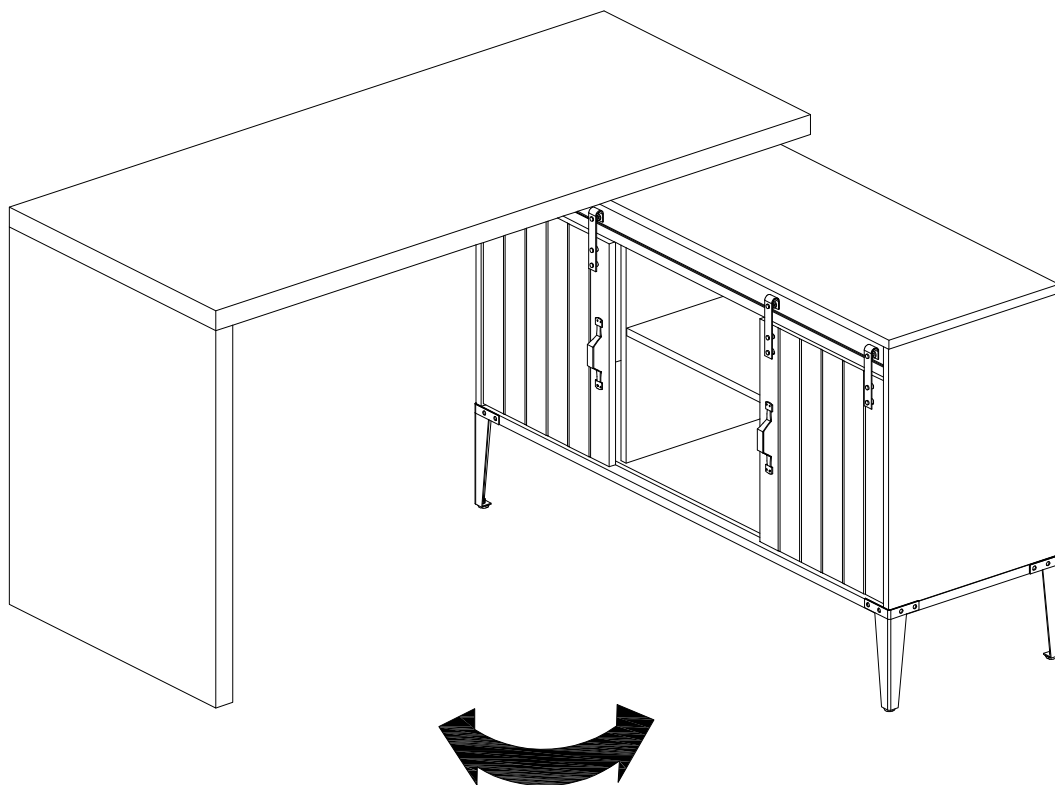

Step 18

or

