

# About the Wood and Finish

This product has been carefully crafted of: MDF, solid pine wood and/or pine veneers. These materials derive from plantations, a renewable and well managed forest, therefore, not endangering the environment. The highest quality standards have been implemented to assure a sturdy and reliable product. Due to the natural variances in the

graining of wood, you may notice subtle differences in the shading and tone of the color stain, warp, holes, wood knots and also small cracks. This is not a defect.

But rather a result of the natural beauty of the wood itself.

**AONNE**  
**FURNITURE**

## Care and maintenance:

Dust when needed using a smooth, dry cloth. Household furniture polish can be used occasionally to restore luster.

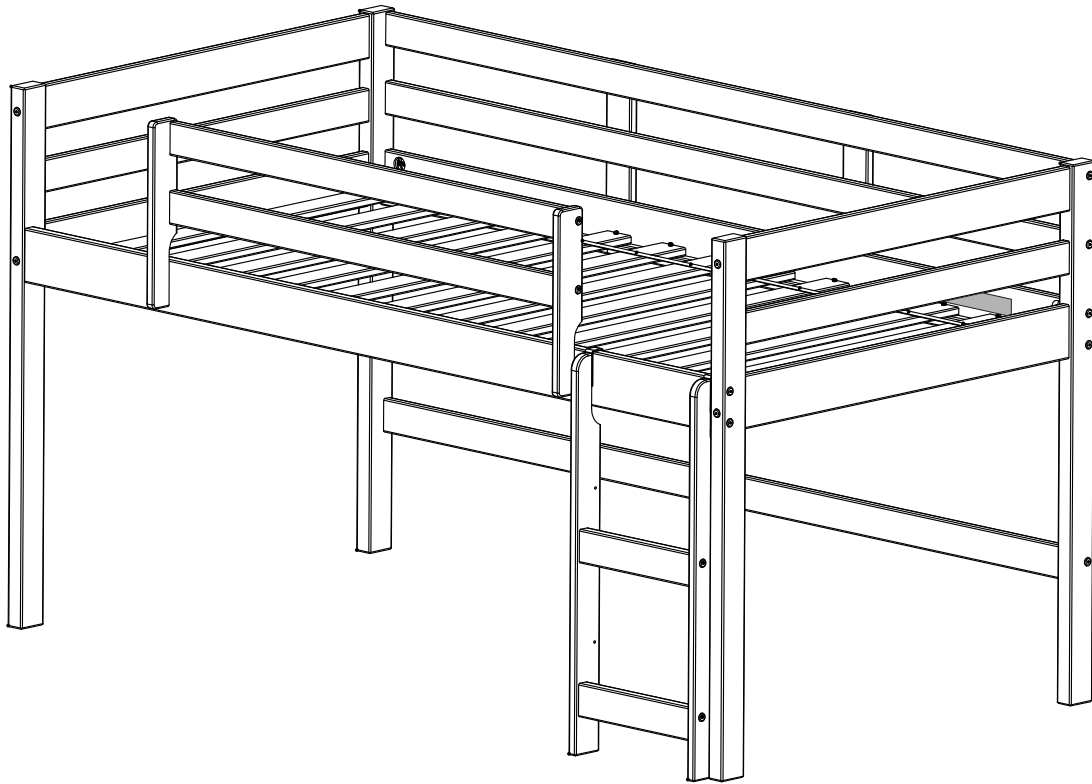

Thank you for purchasing this quality product. Be sure to check all packing material carefully for small parts which may have come loose inside the carton during shipment. Separate identify and count all parts and hardware.

Compare with the parts list to be sure all parts are present.

**"DO NOT TIGHTEN SCREWS UNTIL COMPLETELY ASSEMBLED"**

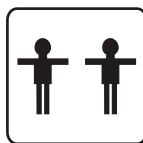
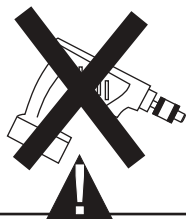

+

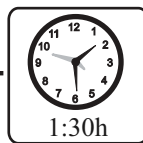

#### Tools Required

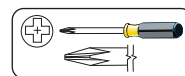

(Not included)

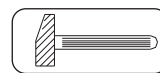

(Not included)

\* Use of power tool to assemble this product will invalidate any claim and damage this product making unsafe !!!  
\* Please assemble on a clean soft surface to avoid damage.

**IMPORTANT:**

**PLEASE READ INSTRUCTION BEFORE STARTING THE ASSEMBLY**

# Part List - 38255 - 38260 LOW LOFT BED



**MANUFACTURER LABEL**  
**DO NOT REMOVE!**

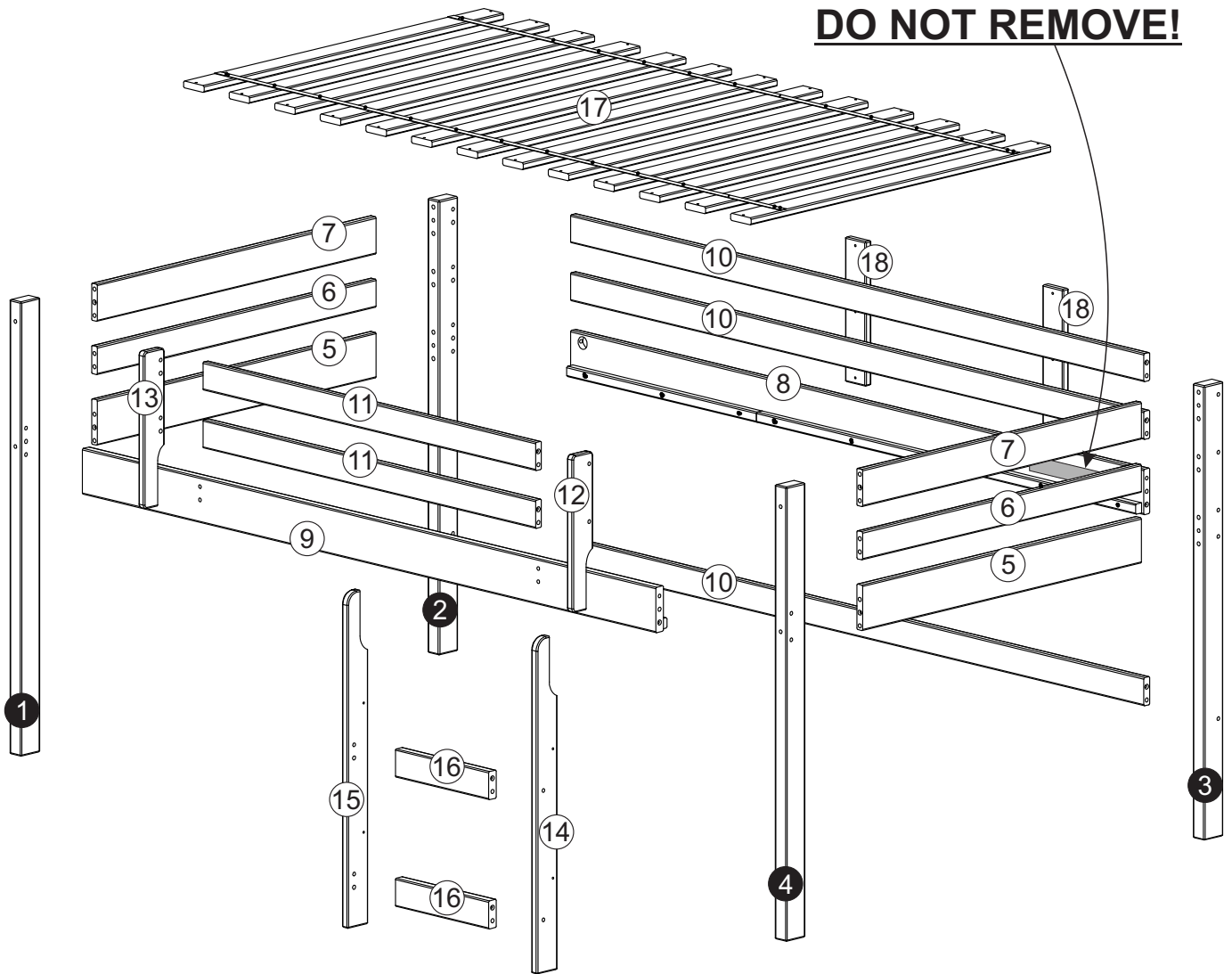

# Identifying the Hardware-Identify the hardware using the illustrations below.

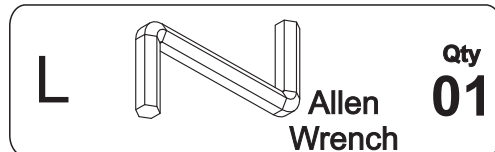
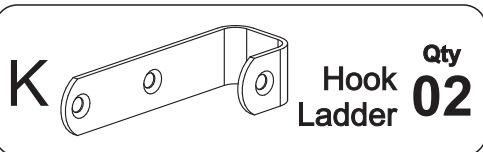
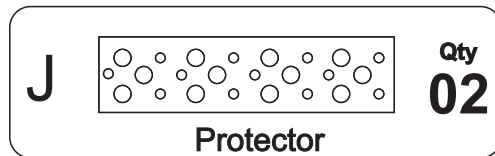
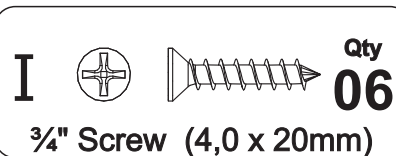
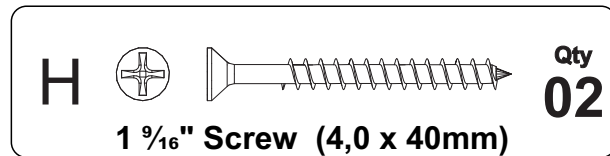
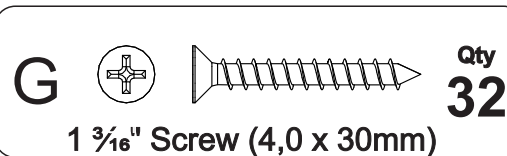
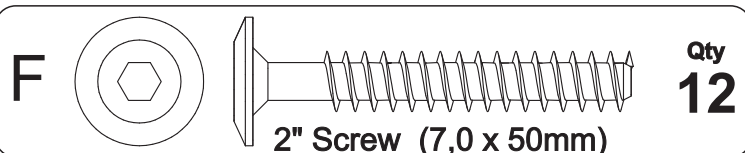
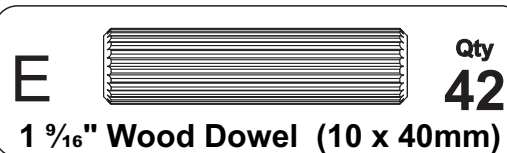
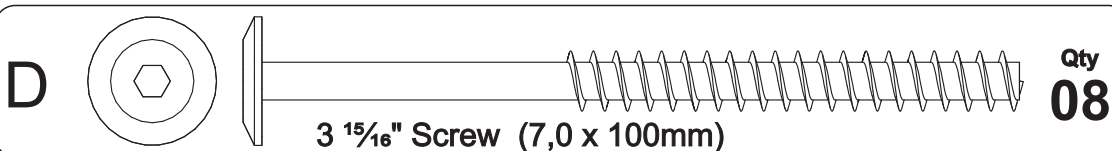
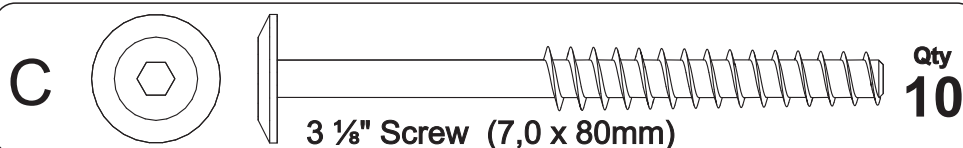
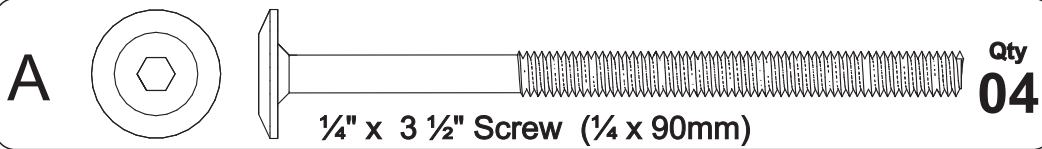

# 01

The hole near  the edge goes down

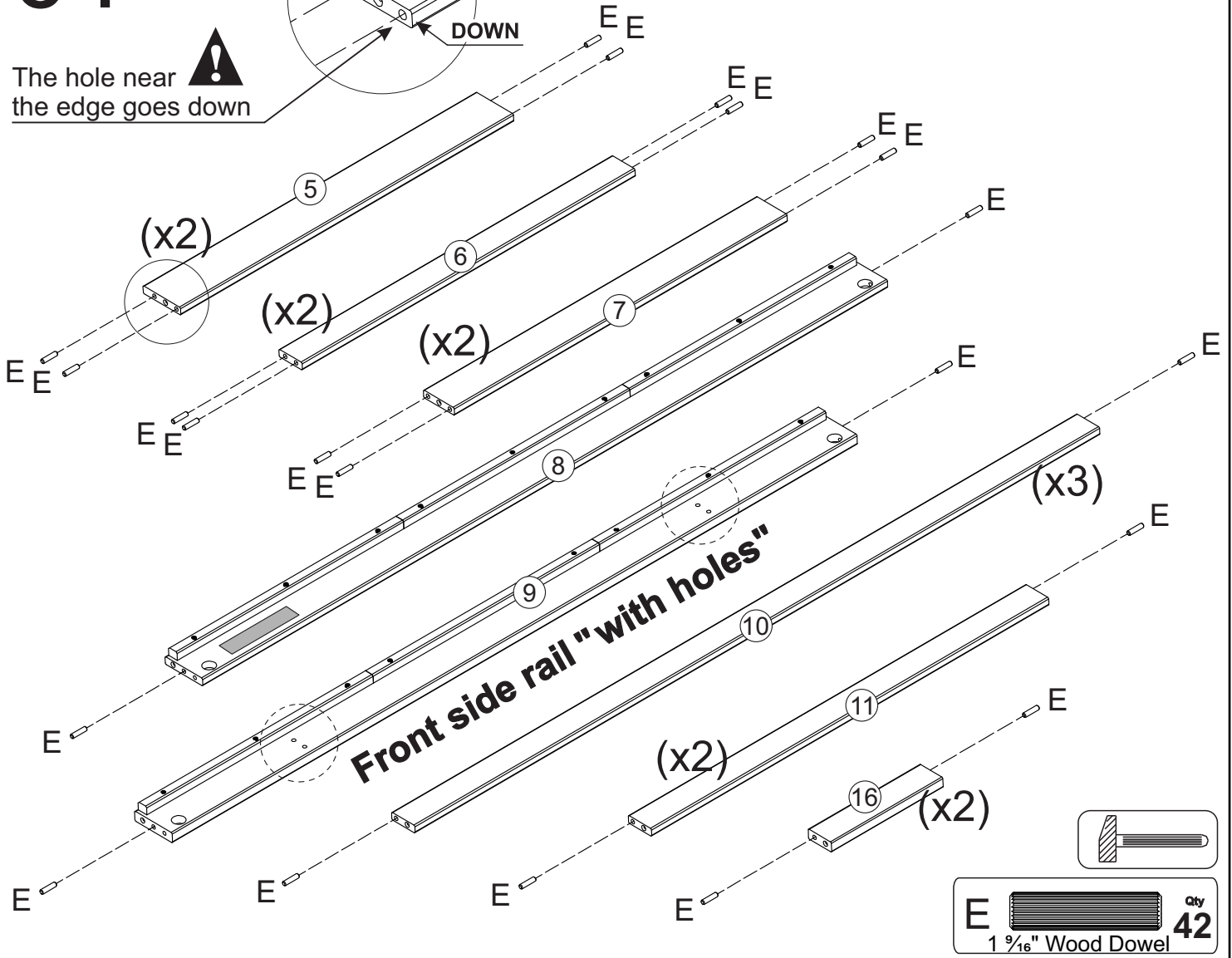
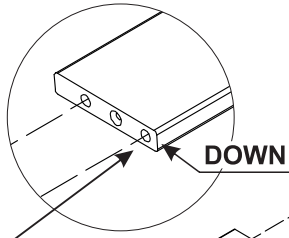

# 02

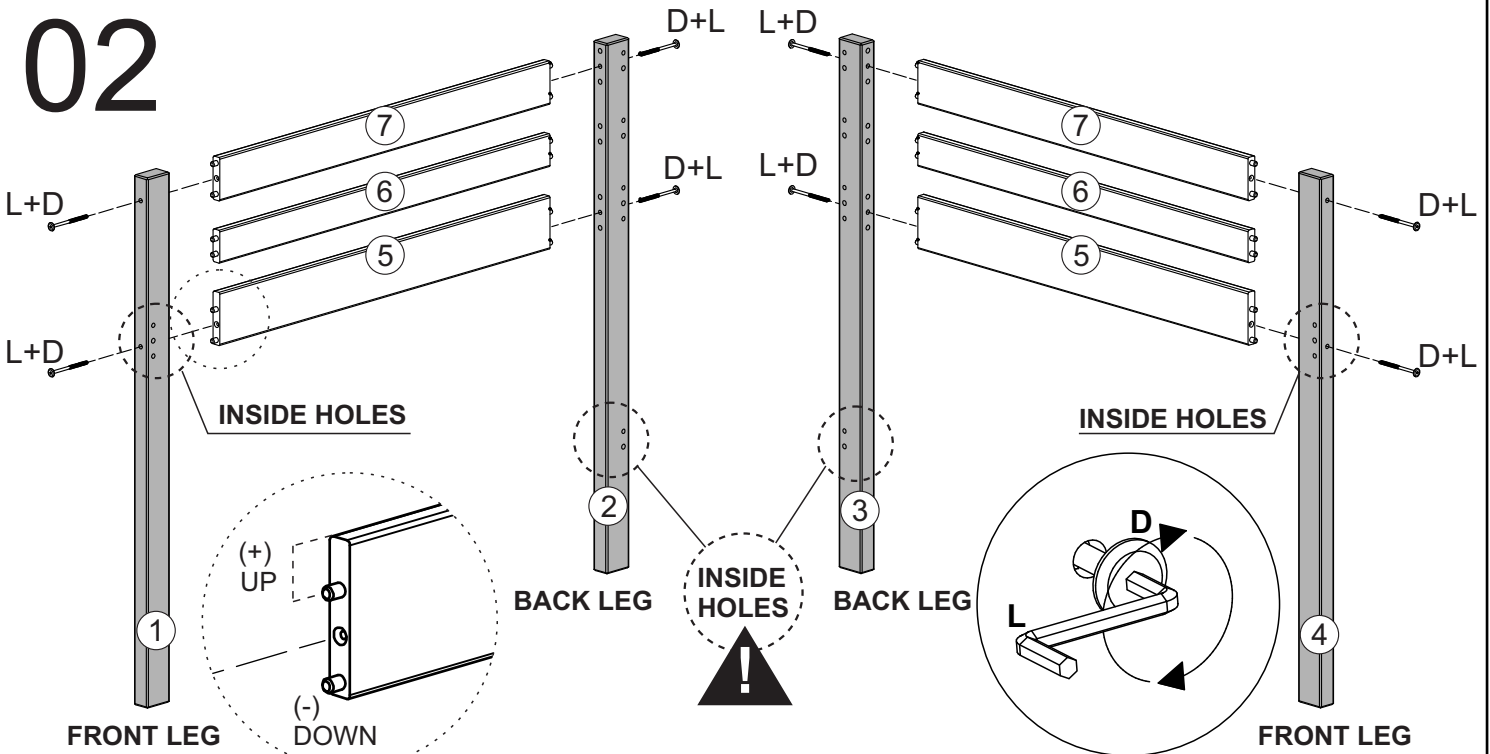

# 03



INSERT AND ATTACH SCREWS (A&B), BUT DO NOT TIGHTEN UNTIL STEP #04

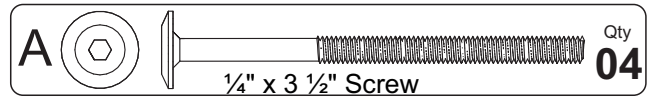
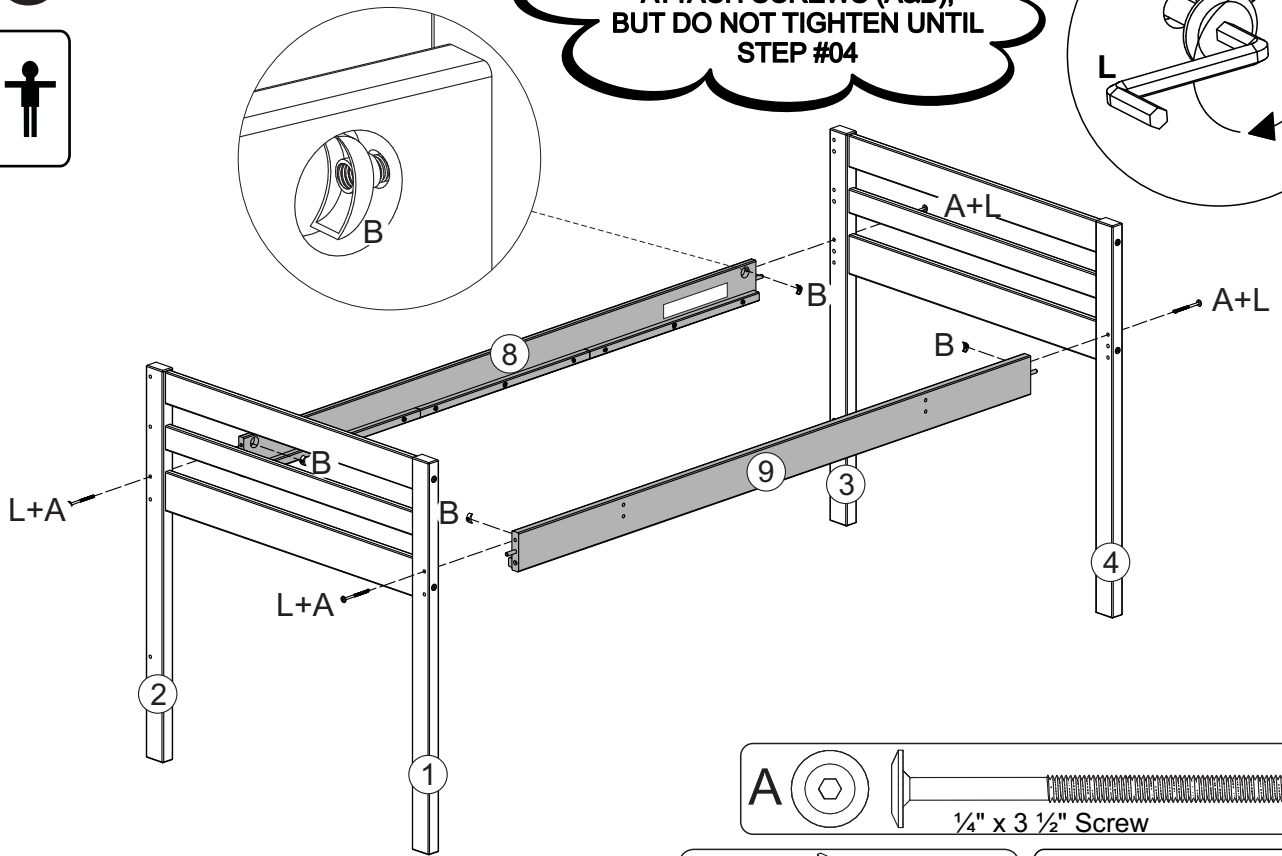
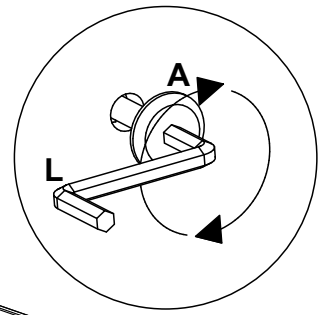

# 04

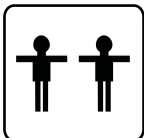

AFTER ATTACHED SCREWS "C" AT THIS TIME, PLEASE TIGHTEN ALL SCREWS!

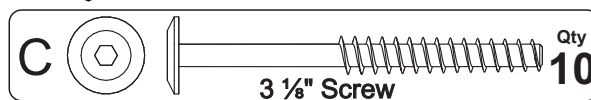
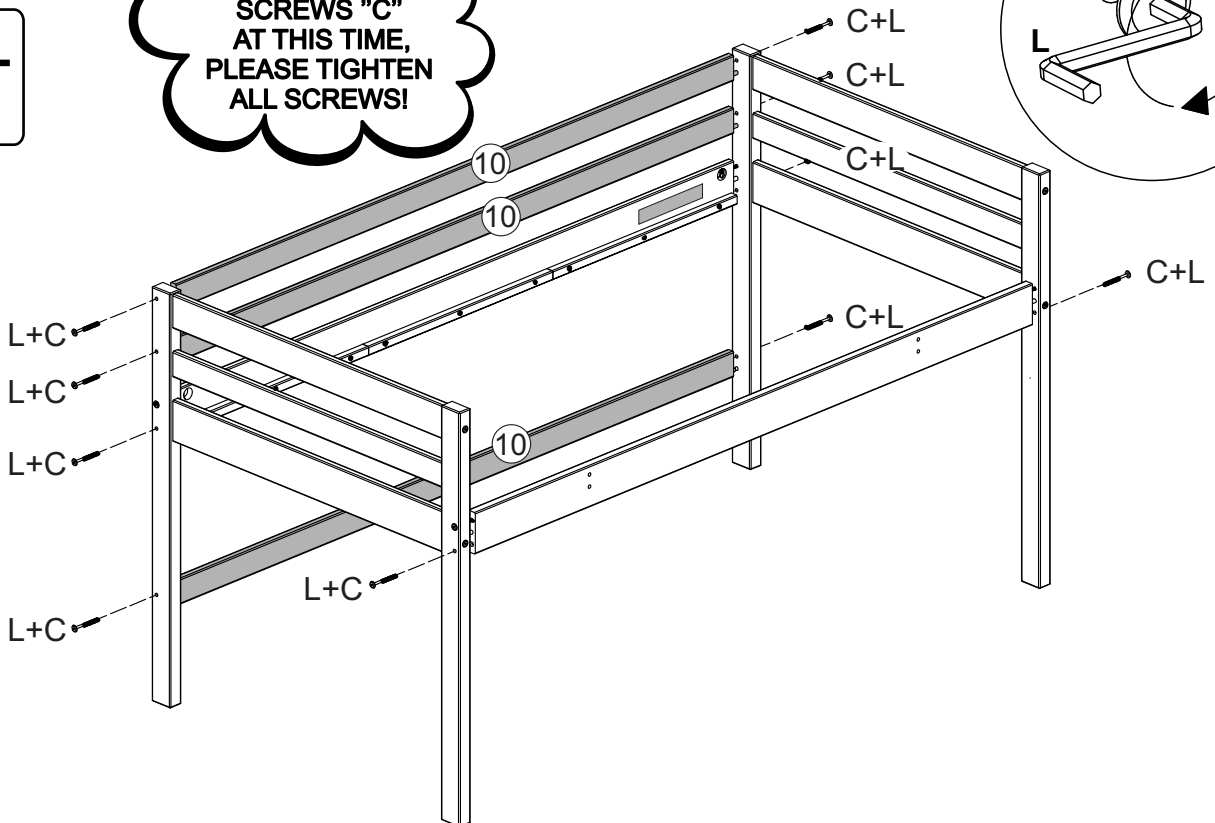
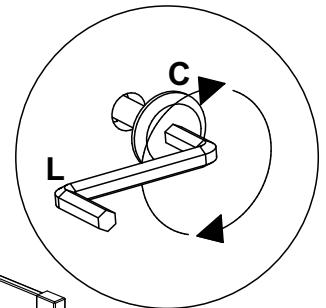

# 05

## FRONT GUARDRAIL

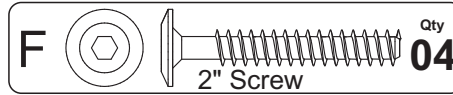
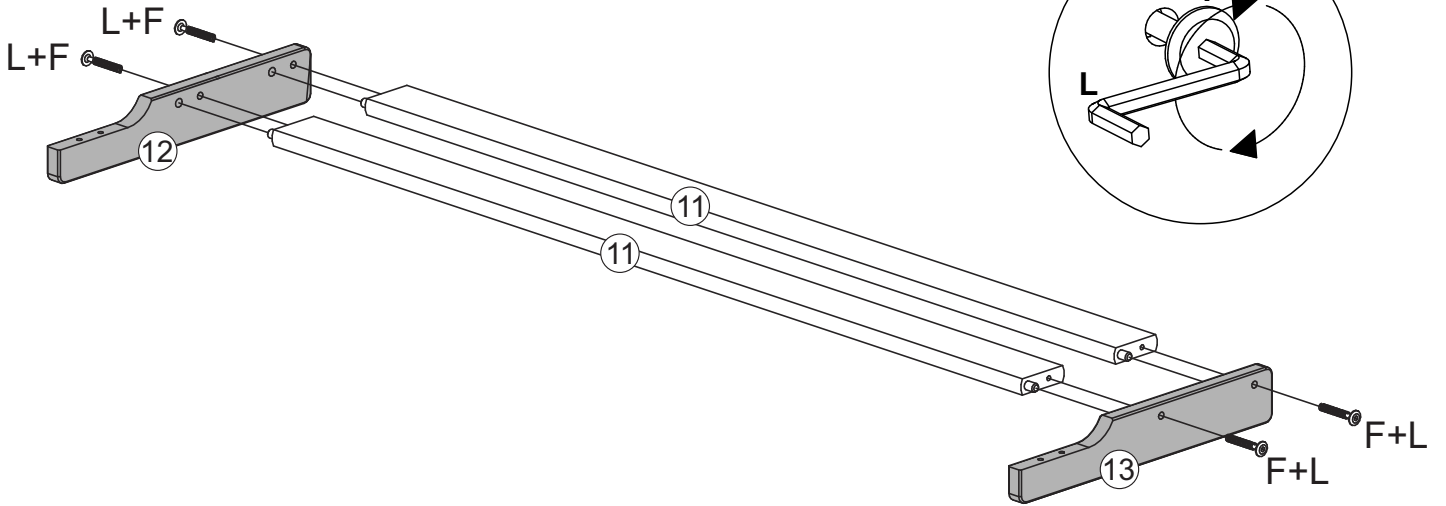

# 06

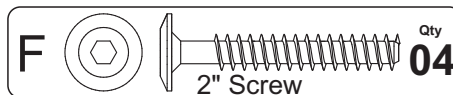
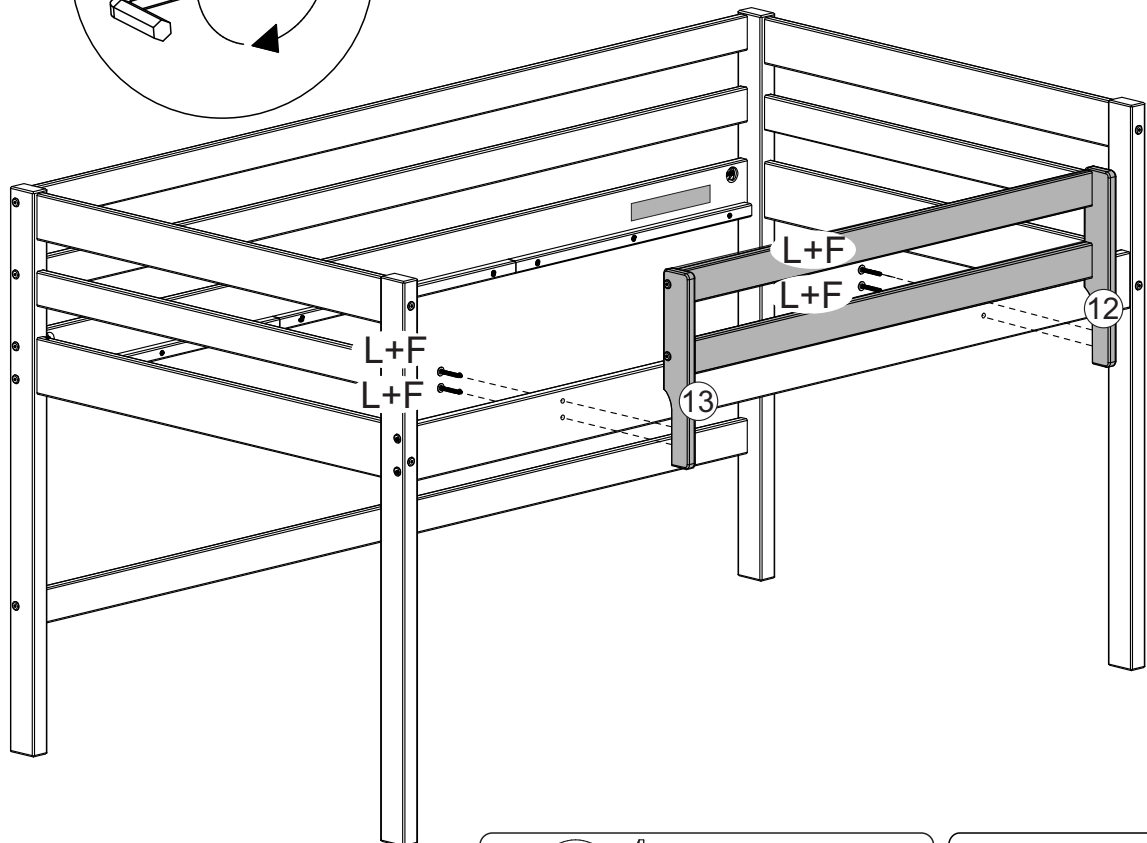
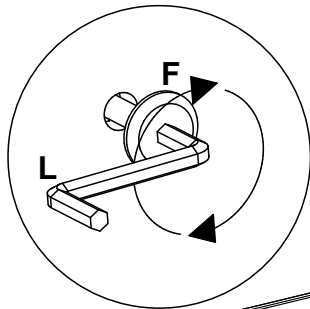

# 07

## LADDER

Step 2



**PRE HOLES!**

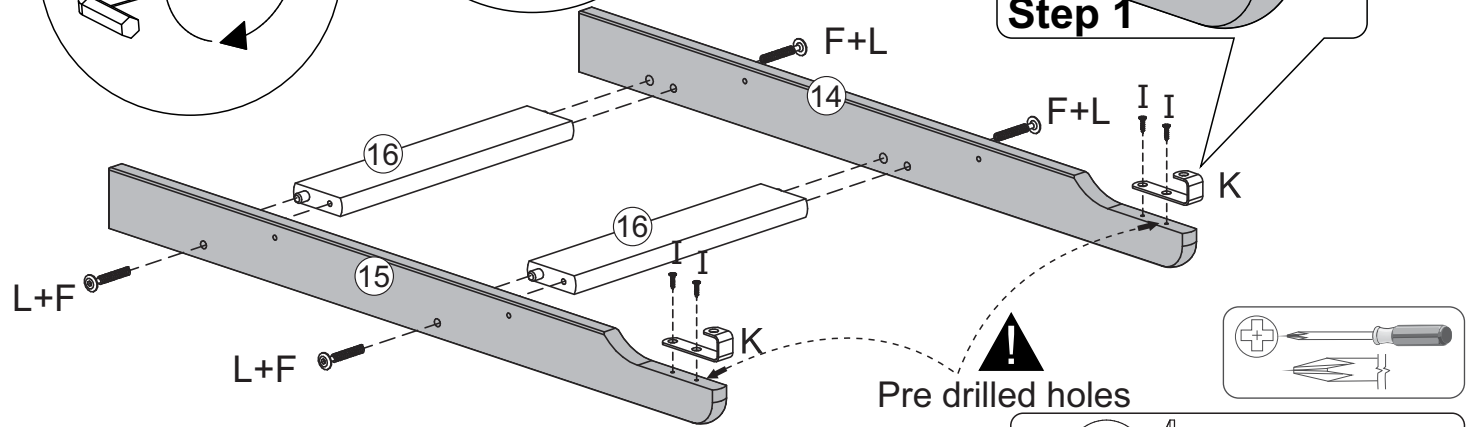
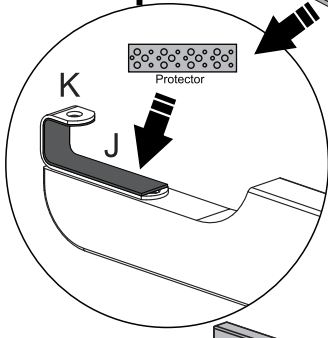
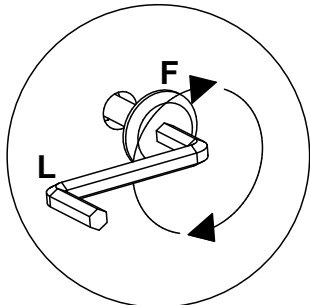
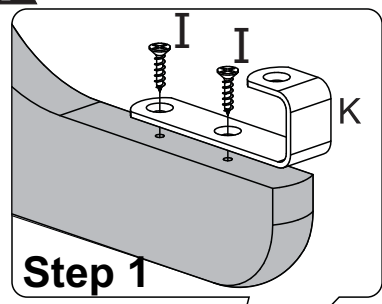

**F** Qty **04**  
2" Screw

**I** Qty **04**  
3/4" Screw

**J** Qty **02**  
Protector

**K** Qty **02**  
Hook Ladder

**L** Qty **01**  
Allen Wrench

# 08

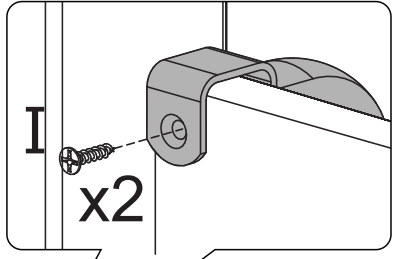
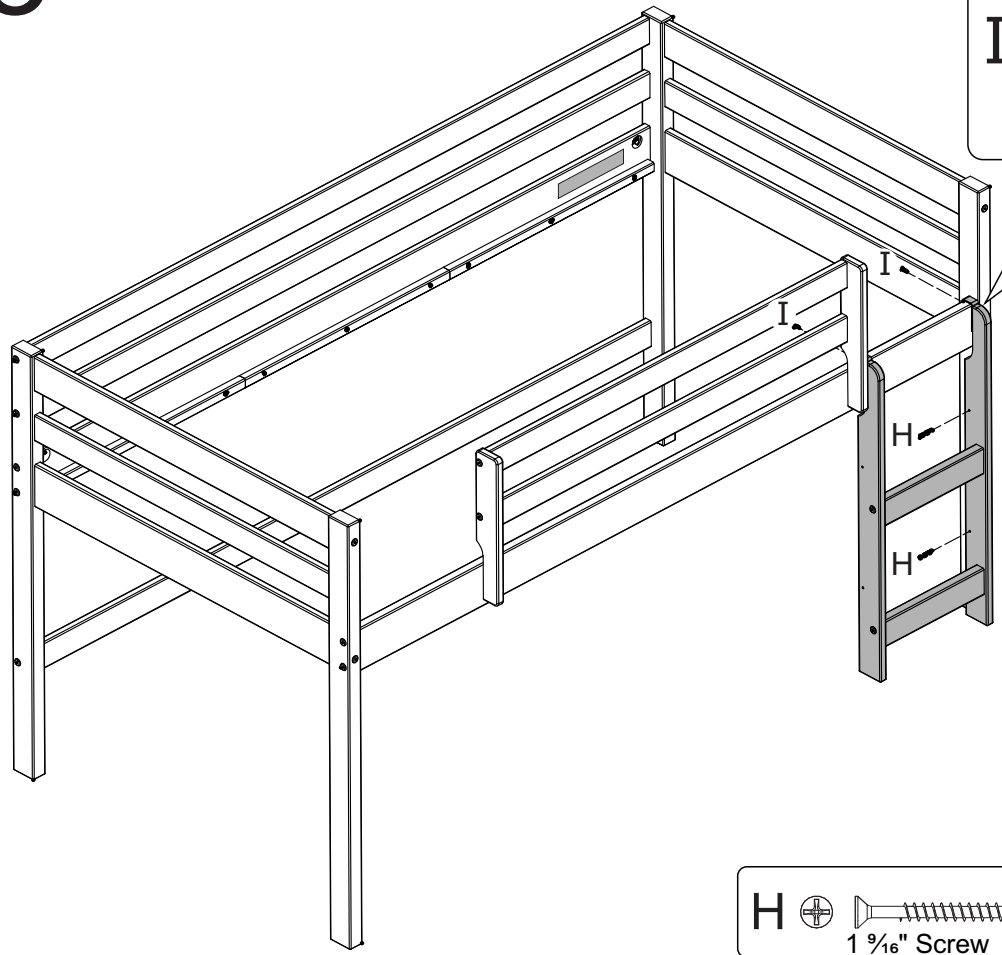

**H** Qty **02**  
1 9/16" Screw

**I** Qty **02**  
3/4" Screw

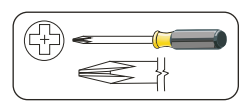



# 09

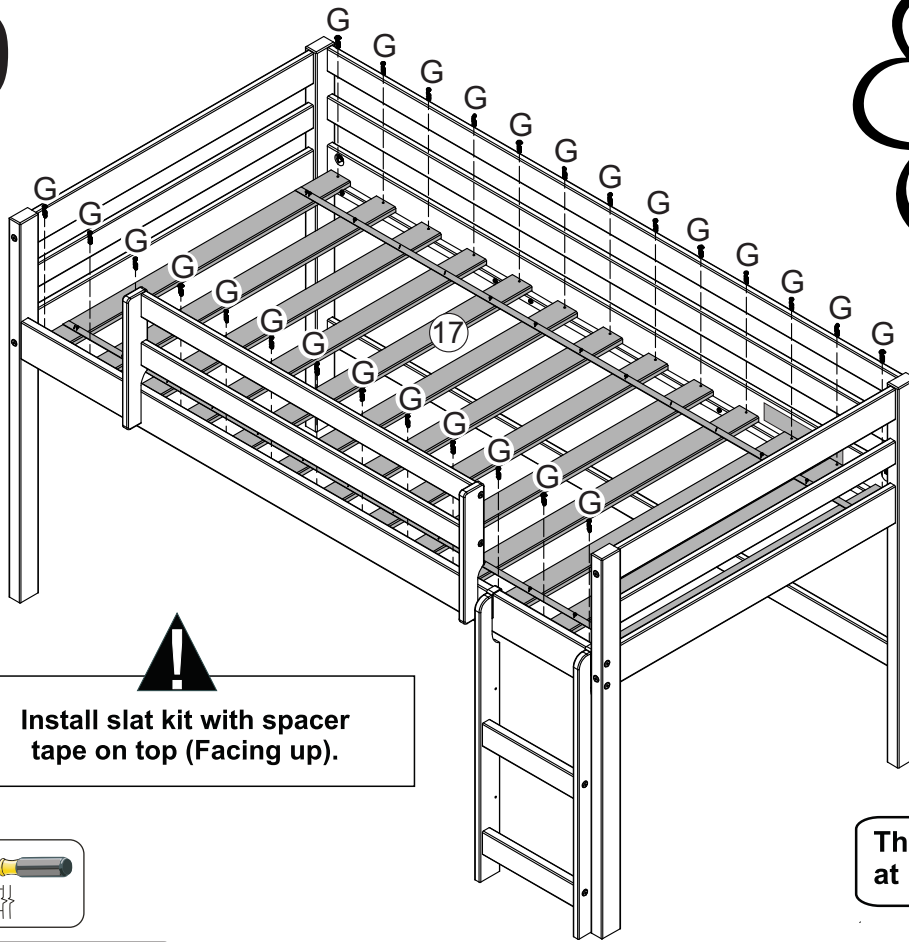

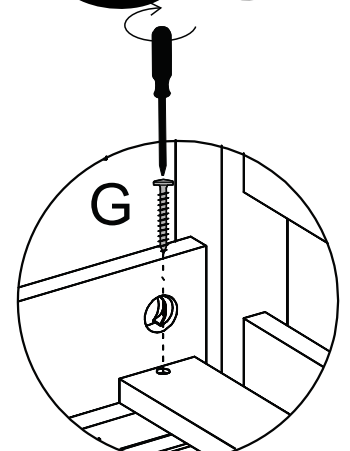

**ATTENTION!**  
There must be at least 5" inches from top surface of mattress to top edge or guardrails.

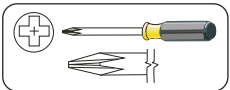

**!**  
Install slat kit with spacer tape on top (Facing up).

**!**  
The first slat must be fixed here at 3" from each headboard end.



**G**  Qty **26**  
1 3/16" Screw

# 10

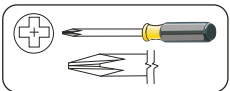
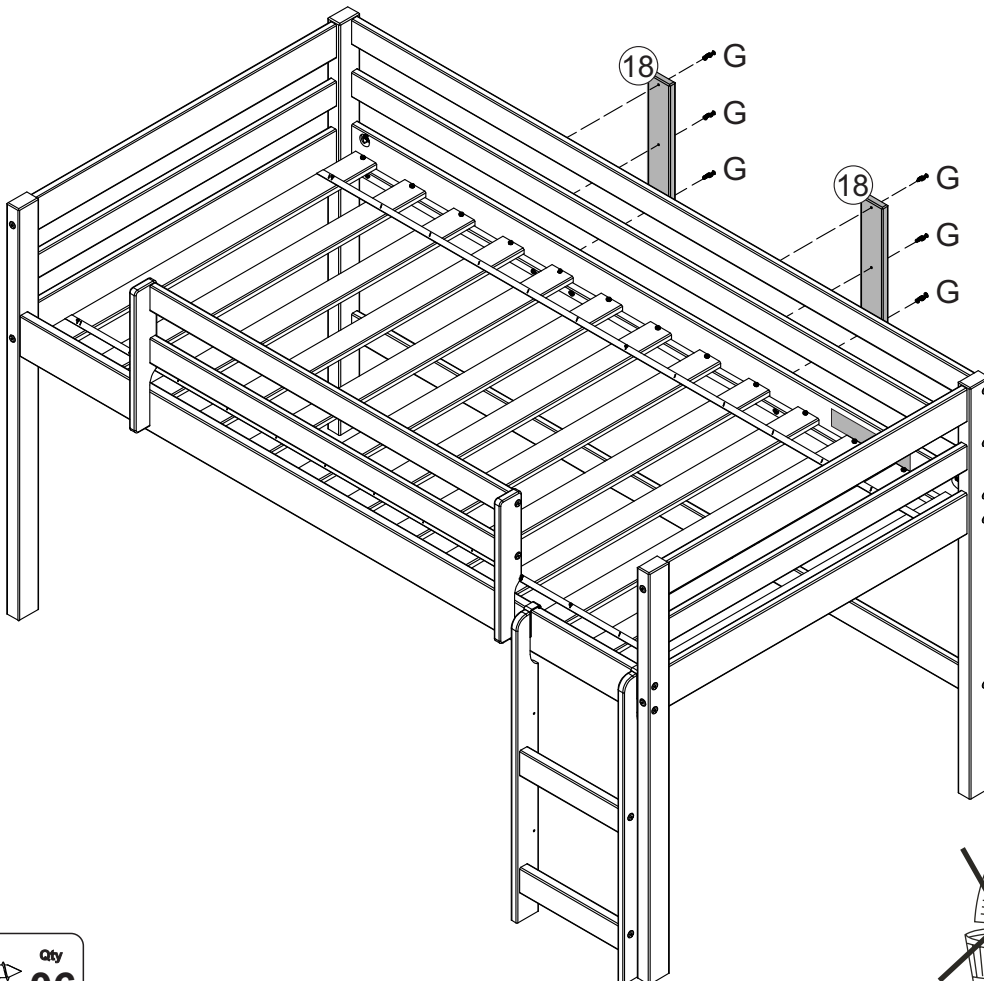

**G**  Qty **06**  
1 3/16" Screw

