



ASSEMBLY INSTRUCTION ITEM NO: 39440HF & 39441RL / 39450HF & 39451RL











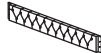

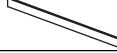
Thank you for purchasing this quality product. Be sure to check all packing material carefully for small parts which may have come loose inside the carton during shipment. Separate, identify and count all parts and hardware. Compare with the parts list to be sure all parts are present.

"DO NOT TIGHTEN SCREWS UNTIL COMPLETELY ASSEMBLED"

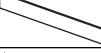
IMPORTANT:

PLEASE READ INSTRUCTION BEFORE STARTING THE ASSEMBLY

HARDWARE LIST				
ITEM	DESCRIPTION	DRAWING	SIZE	QTY
A	JCBB SCREW		M8 X 20 MM	16PCS
B	JCBC SCREW		M6 X 50MM	20PCS
C	SPRING WASHER		M6 X 12MM	16PCS
D	FLAT WASHER		M6 X 19MM	4PCS
E	FLAT WASHER		M6 X 13MM	12PCS
F	SCREW		M4 X 16MM	24PCS
G	SCREW		M4 X 32MM	16PCS
H	L - KEY		M4 X 65MM	1PC
I	L - KEY		M5 X 65MM	1PC

PART LIST			
ITEM	DESCRIPTION	DRAWING	QTY
1	BACK REST		1PC
2	SIDE PANEL (L)		1PC
3	SIDE PANEL (R)		1PC
4	FRONT SIDE RAIL		1PC
5	BACK SIDE RAIL		1PC
6	LEGS		4PCS
7	DAYBED SLAT		2 SETS
8	TRUNDLE FRONT RAIL		1PC
9	TRUNDLE BACK RAIL		1PC
10	TRUNDLE SIDE RAIL		2PCS
11	TRUNDLE SLAT		2 SETS
12	SUPPORT SLAT		3PCS
13	CASTOR		6PCS

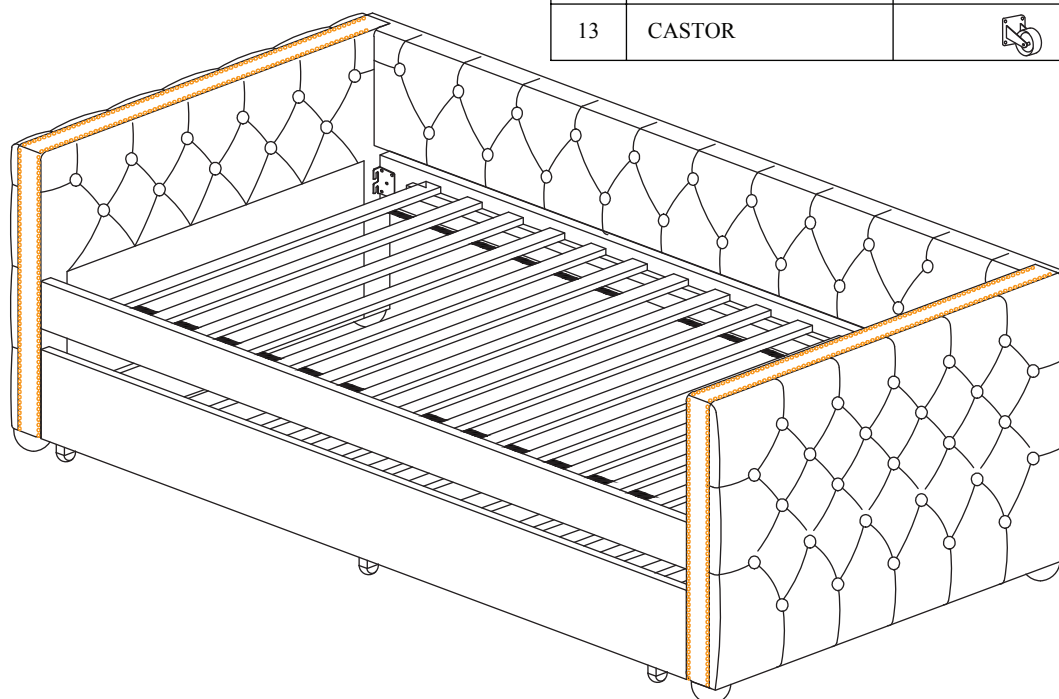

ASSEMBLY INSTRUCTION

ITEM NO : 39440HF & 39441RL / 39450HF & 39451RL

STEP 1

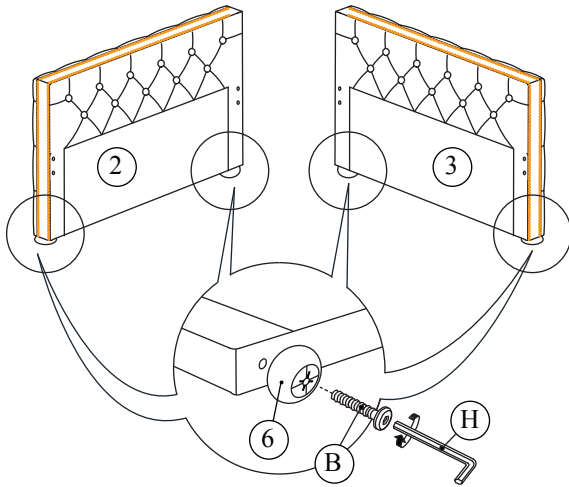

STEP 2

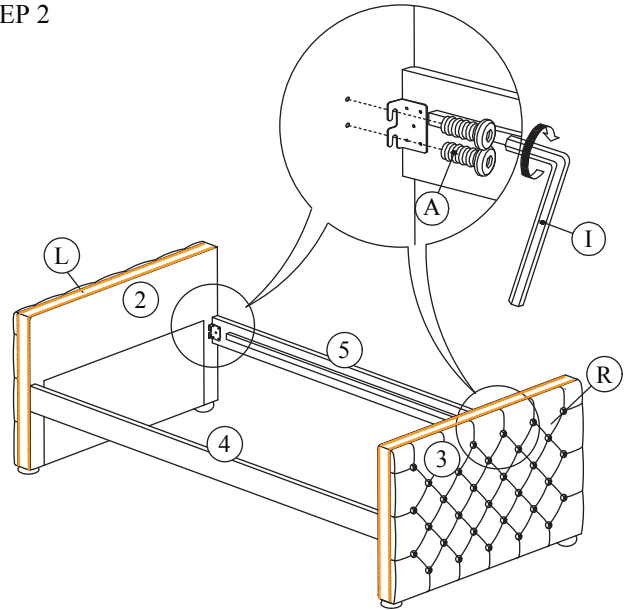

STEP 3

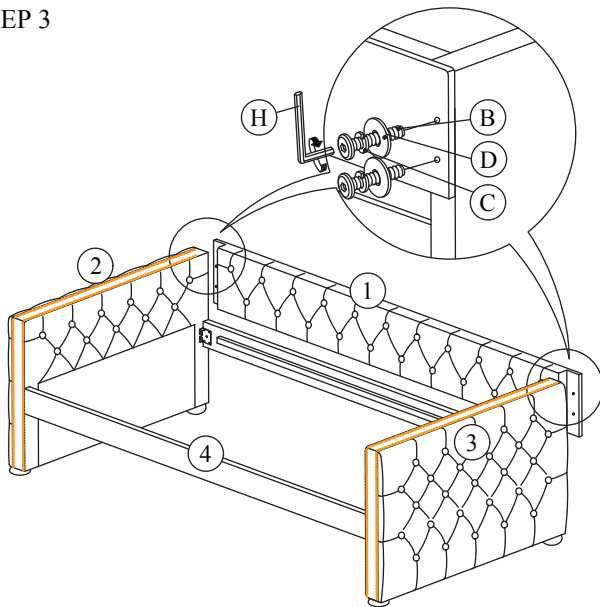

STEP 4

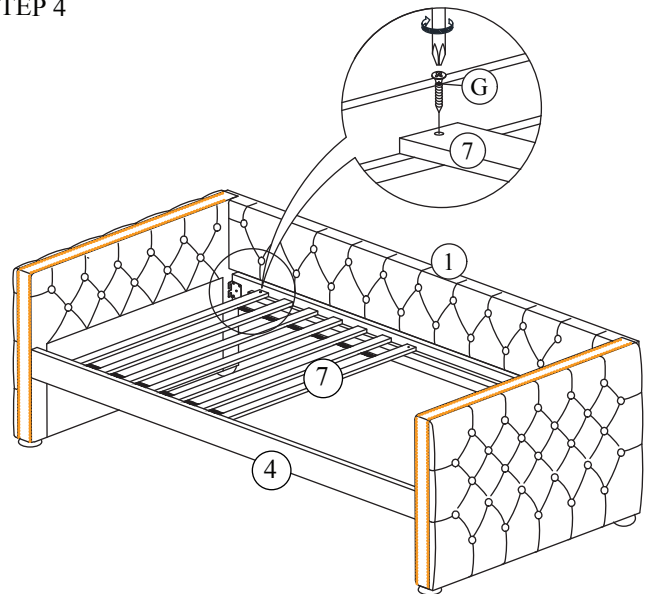

STEP 5

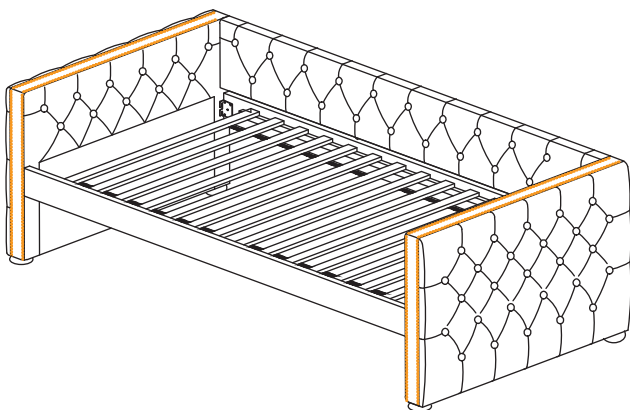

STEP 6

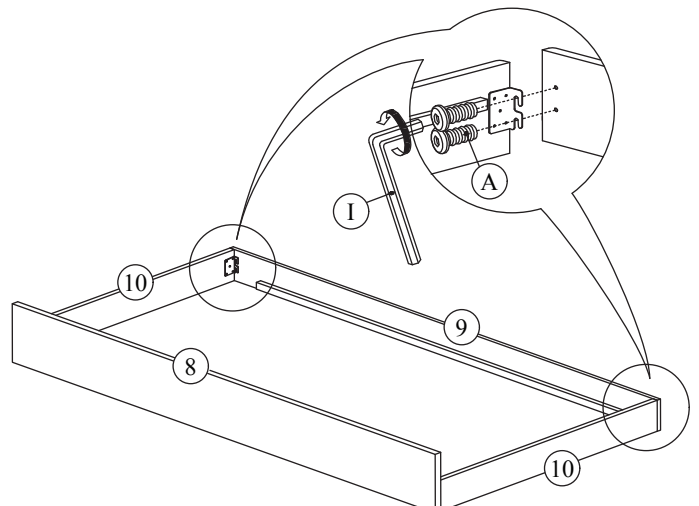

ASSEMBLY INSTRUCTION

ITEM NO : 39440HF & 39441RL / 39450HF & 39451RL

STEP 7

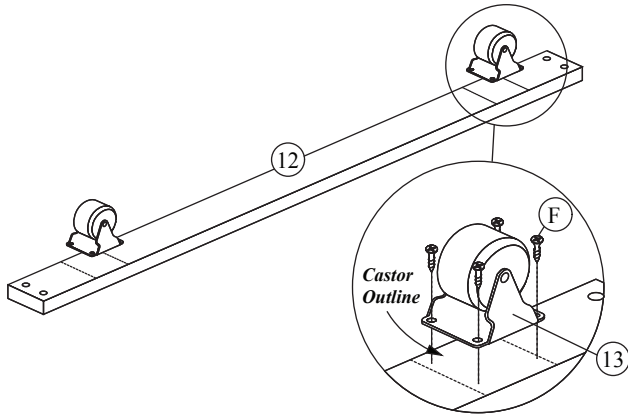

STEP 8

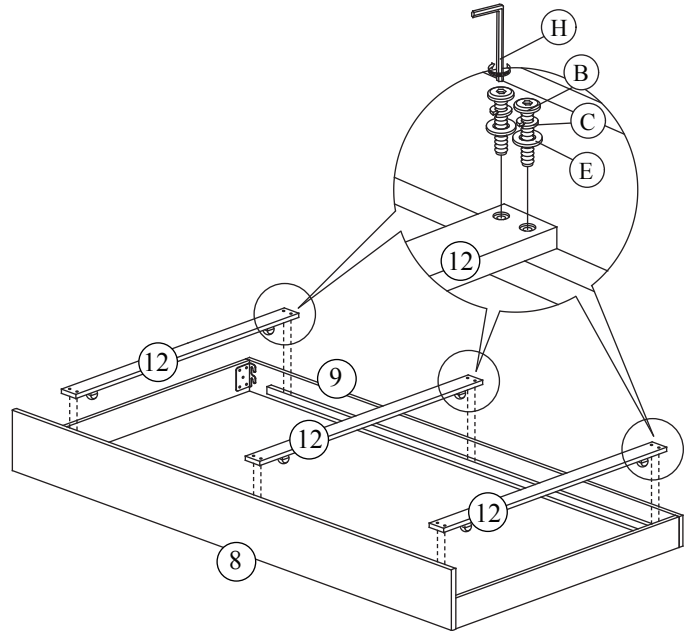

STEP 9

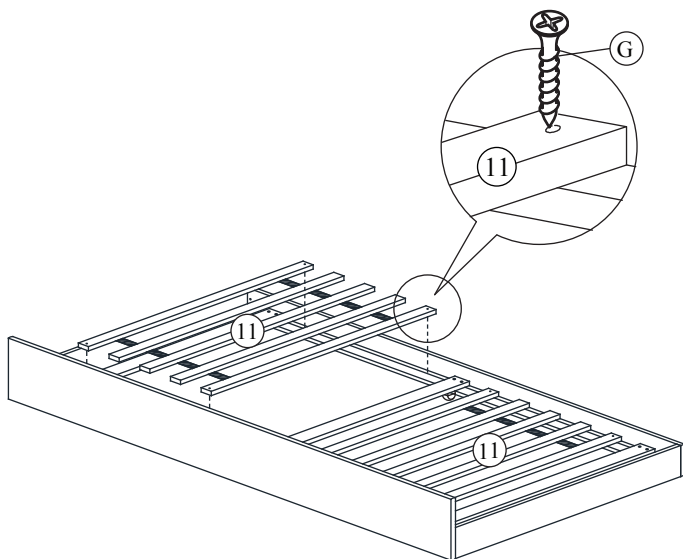

STEP 10

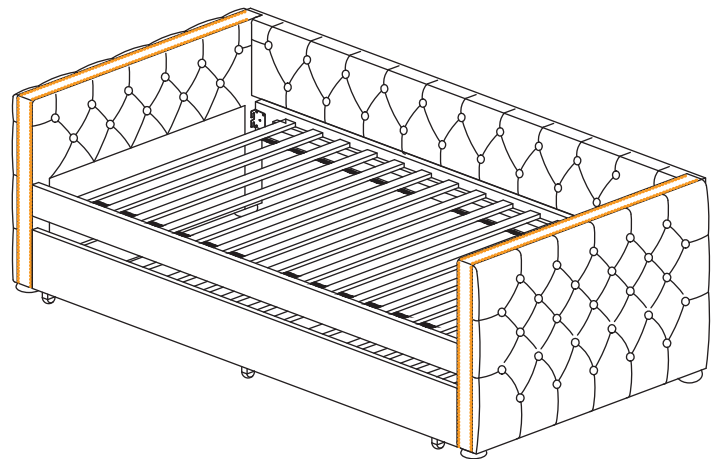

ASSEMBLY
COMPLETE