









# ASSEMBLY INSTRUCTIONS FOR ACME FURNITURE











## MODEL#28957EK / #28958EK

Thank you for purchasing the quality product. Be sure to check all packing material carefully for small parts which may have come loose inside the carton during shipment. Separate, identify and count all parts and metal hardware. Compare with all parts list to be sure all parts are present. If any part(s) are missing or damaged, please contact your local furniture dealer. For efficient and speedy service, please indicate the model number and code letter or part(s) needed.

**\*\*\*Do not fully tighten screws until fully assembled\*\*\***

| DESCRIPTION | COMPONENT PART   |       |
|-------------|--|-------|
|             | PART NAME  | QTY   |
| ①           | Headboard        | 1pc   |
| ②           | Footboard        | 1pc   |
| ③           | Side Rail        | 2pcs  |
| ④           | Legs            | 4pcs  |
| ⑤           | Center Rail      | 2pcs  |
| ⑥           | Support Legs  | 4pcs  |
| ⑦           | Slat           | 42pcs |
| ⑧           | Side Wing     | 2pcs  |

### HARDWARE REQUIRED

- (A)  JCBC M6 x 40 - 4pcs
- (B)  JCBC M6 x 60 - 4pcs
- (C)  M4 x 65mm - 1pc
- (D)  M5 x 70mm - 1pc
- (E)  CSK Screw 25mm - 4pcs
- (F)  Middle Holder - 28pcs
- (G)  End Holder - 28pcs
- (H)  Spring Washer - 4pcs
- (I)  Flat Washer - 4pcs
- (J)  N0.35 Washer - 4pcs
- (K)  JCBB M8 x 20 - 8pcs

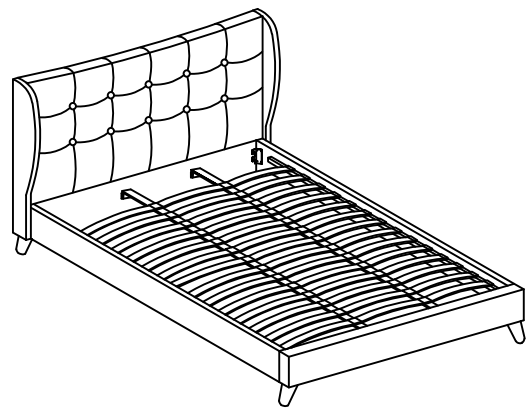

#### Attention:

\*\*\* Some number parts listed on the instruction sheet may not be in parts bag as they may already be assembled. Carefully check parts and packing materials prior to ordering replacements.

## How to assemble:

**STEP 1 :** Unzip the black non-woven fabric on the back of headboard (1) and take out the side wing (8).

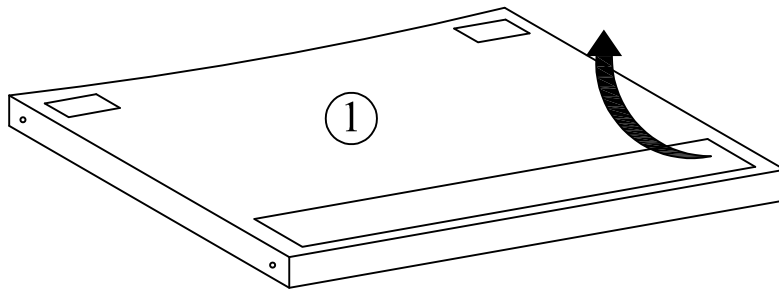

**Back View !!**

**STEP 2 :** Install the legs (4) to footboard (2) and headboard (1).

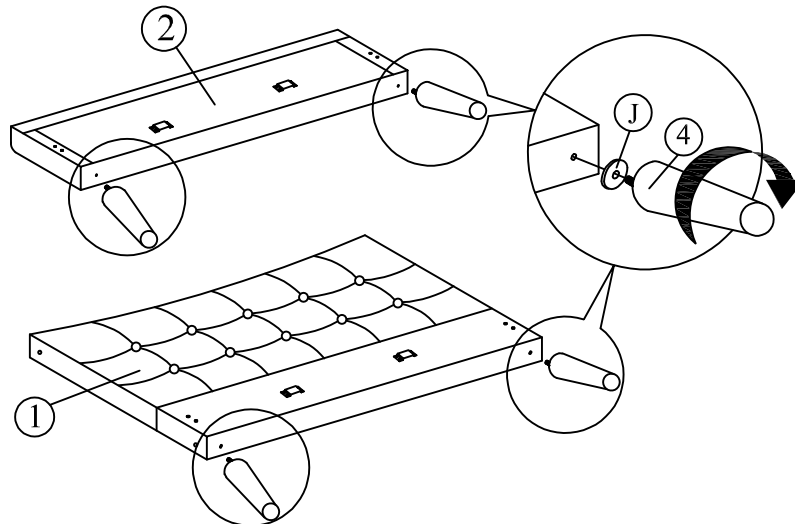

**STEP 3 :** Tighten the side wing (8) to headboard (1) as shown.

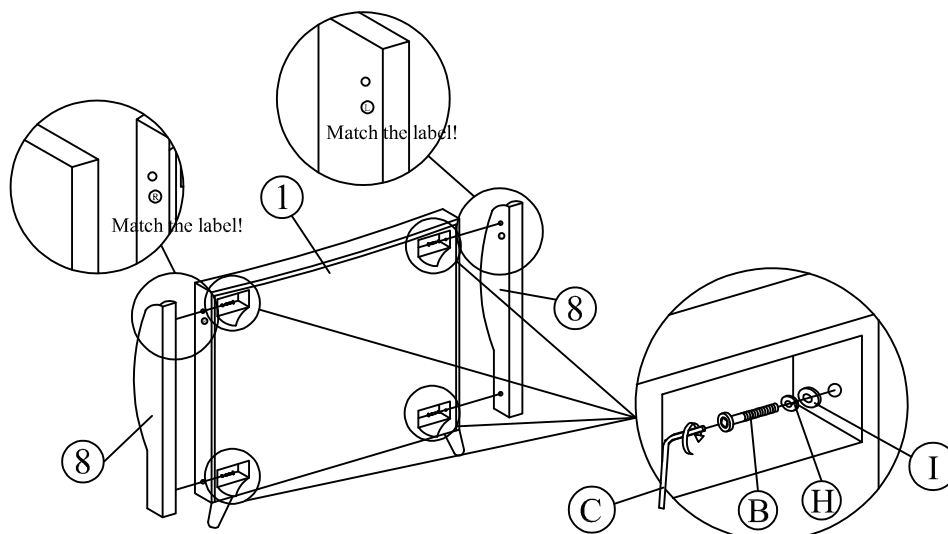

**STEP 4 :** Attach side rail (3) to footboard (2) and headboard (1) by pushing the bracket down to fit it.

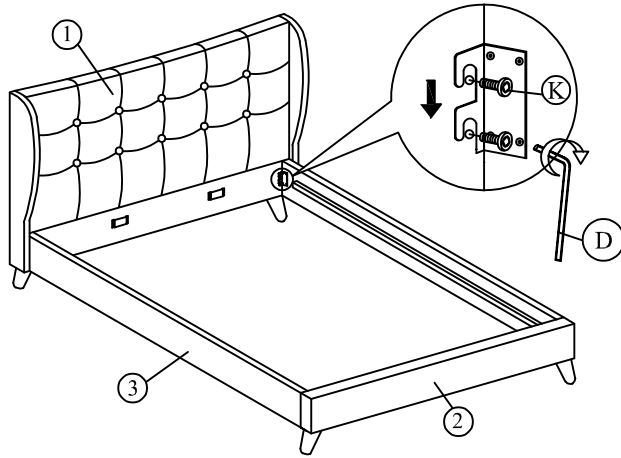

**STEP 5 :** Attach the support legs (6) to the center rail (5) of the bed as shown.

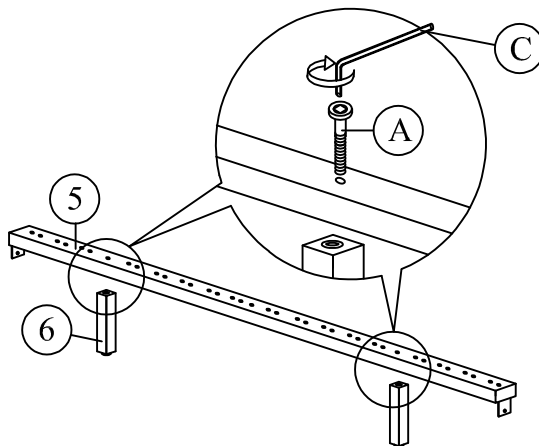

**STEP 6 :** Slide the center rail (5) to the headboard (1) and footboard (2). Tighten screws (E) using screw driver (not included) to the headboard (1) and footboard (2).

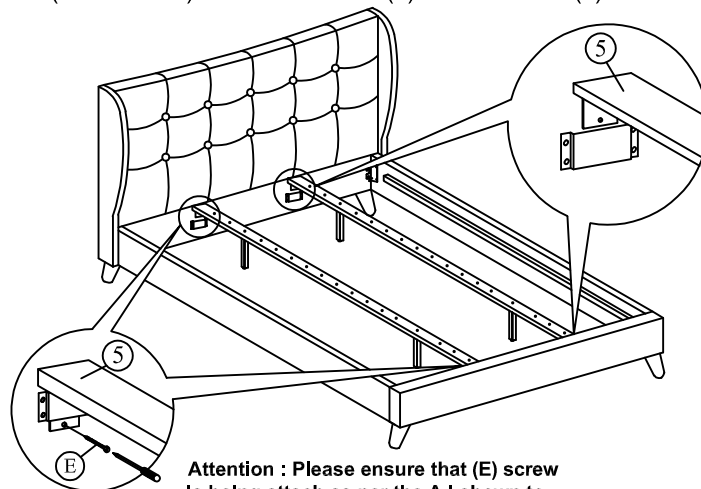

**Attention :** Please ensure that (E) screw is being attach as per the A.I shown to avoid base being collapse.

**STEP 7 :** Tighten all the 4 corner, follow by assembly of the slat holders with LVL slats as shown.

