

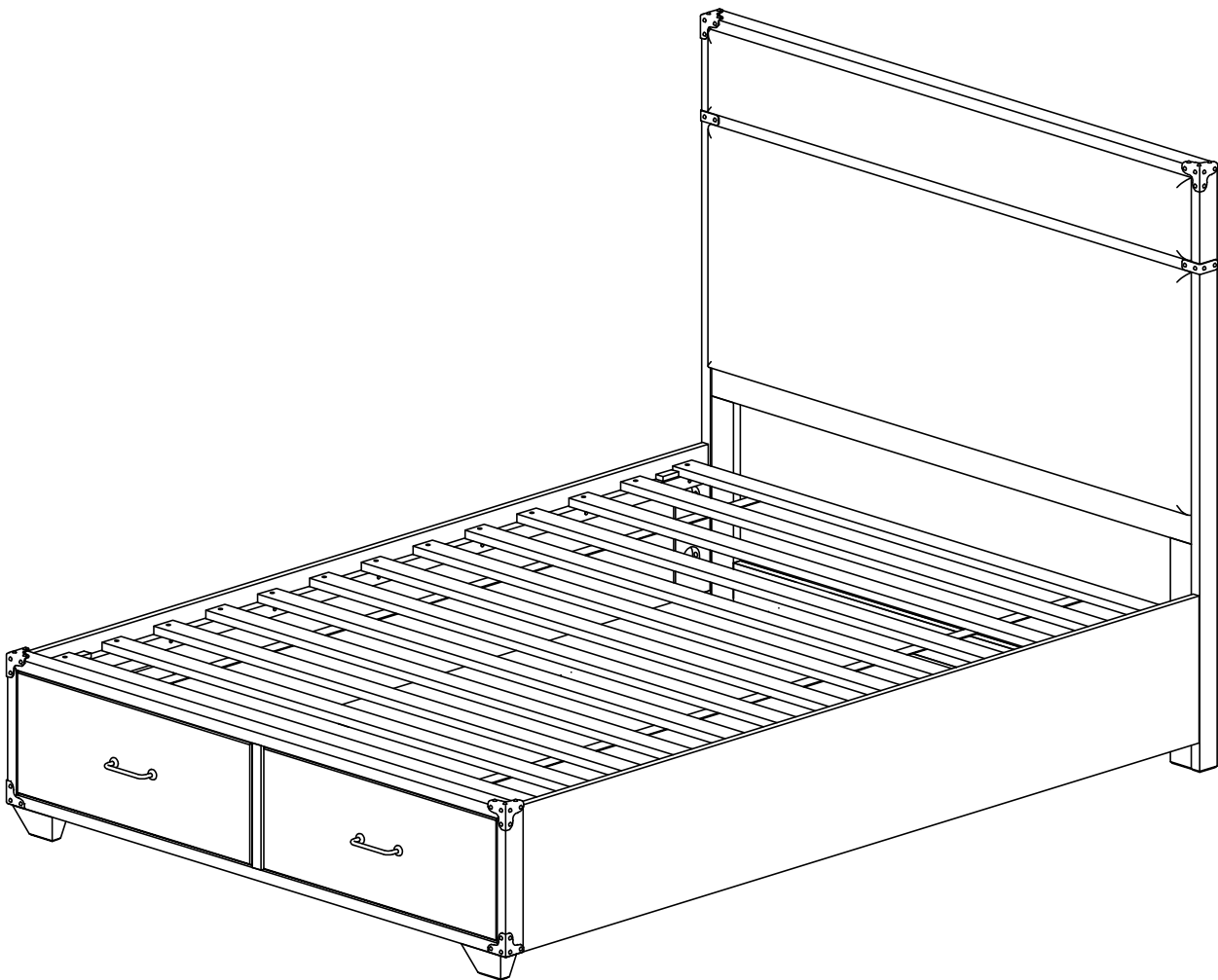





\*\*\* Thank you for purchasing this quality product. Be sure to check all packing materials carefully for small parts which may have come loose inside the carton during shipment. Identify and count all parts and compare with parts list below.

\*\*\* Assemble product on a flat, soft surface such as a carpet or cloth to prevent scratching the finish. Read all instruction and study the drawings carefully before starting the assembly process.





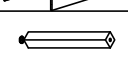

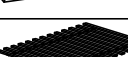
**IMPORTANT:** Do not tighten bolts completely until all bolts are completely lined up and inserted into holes

## PARTS LIST



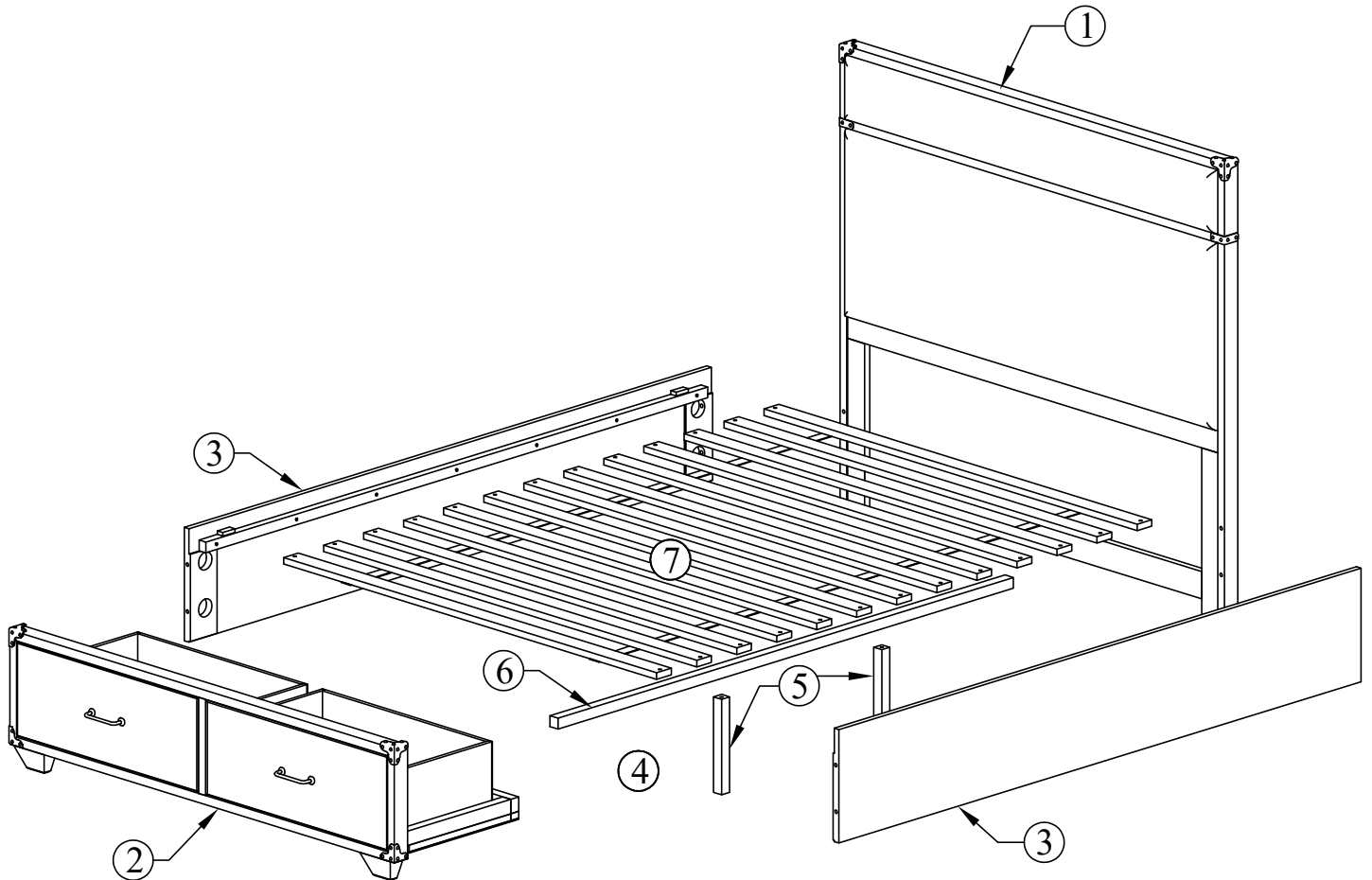

NO.	DIAGRAM	PART NAME	Q'Ty
1		Headboard	1 pc
2		Footboard	1 pc
3		Side Rails	2 pcs
4		Support Leg	2 pcs
5		Support Slat	1 pc
6		Slat	1 Set

## HARDWARE LIST

NO.	DIAGRAM	PART NAME	Q'Ty
A		Bolt 7.8 x 90 (mm)	8 pcs
B		Flat Washer: 7.8 x 29 x 8 (mm)	8 pcs
C		Hex Nut: 7.8 x 13 x 10 (mm)	8 pcs
D		Spanner Wrench (M12)	1 pc
E		Screw: 4 x 35 (mm)	29 pcs

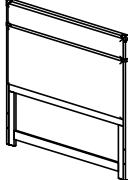
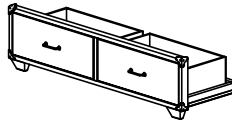
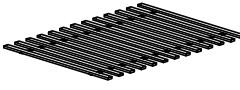
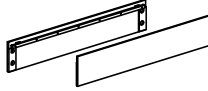
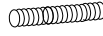
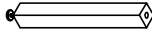

# #36135F is packed in 3 cases

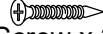
Carton	Disignation	Part		Hardware
<b>Item: #36125F-HB</b>	Headboard x 1pc	#1		
<b>Item: #36136F-FB</b>	Footboard x 1pc	#2		
	Slats x 13pcs	#6		
<b>Item: #36137F-R</b>	Side Rails x 2pcs	#3		 A :Bolt x 8pcs
	Support Leg x 2pcs	#4		 B :Flat Washer x 8pcs
	Support Slat x 1pc	#5		 C :Hex Nut x 8pcs   D :Spanner Wrench (M12) x1pc   E :Screw x 29pcs

## **STEP 1: HANDLE ASSEMBLY**

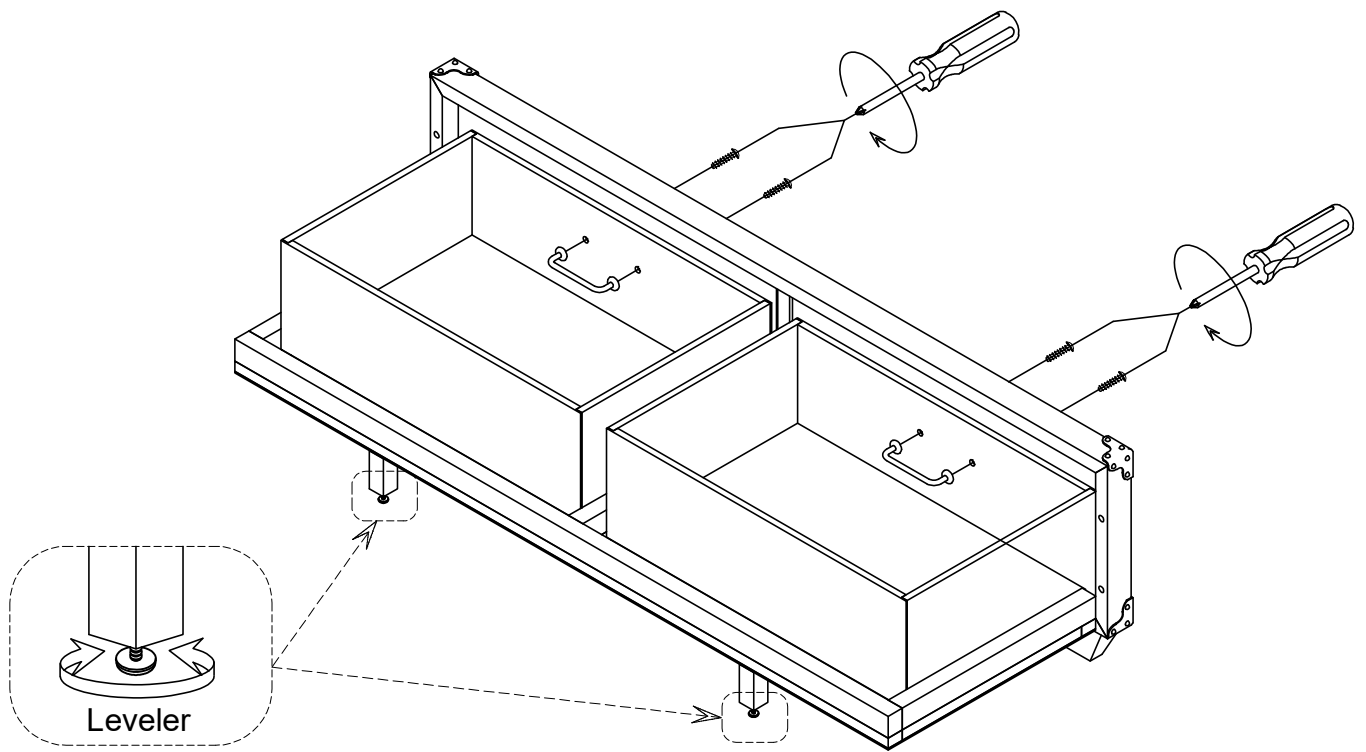

## **STEP 2: HANDLE ASSEMBLY**

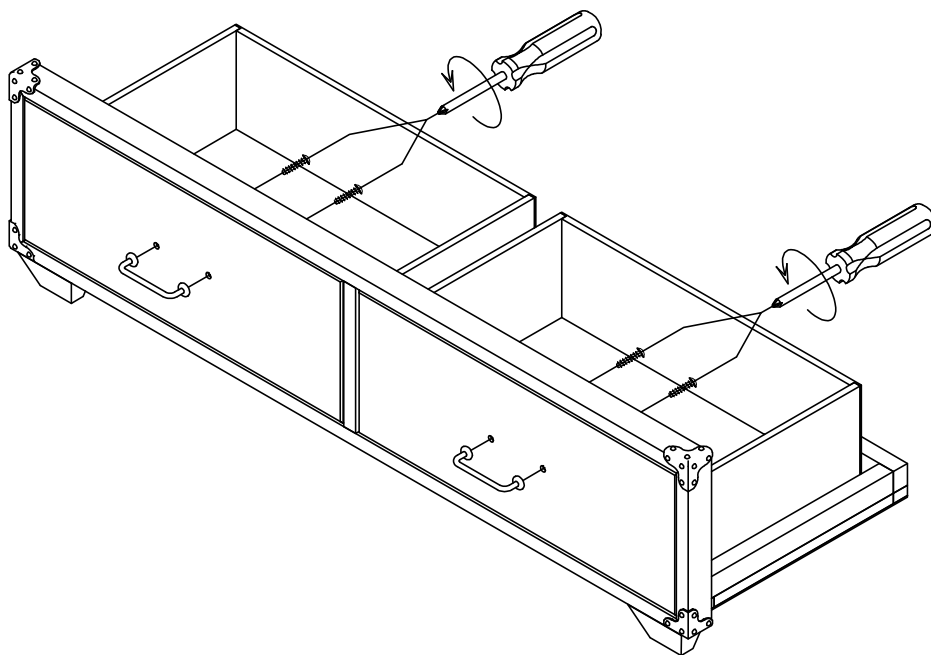



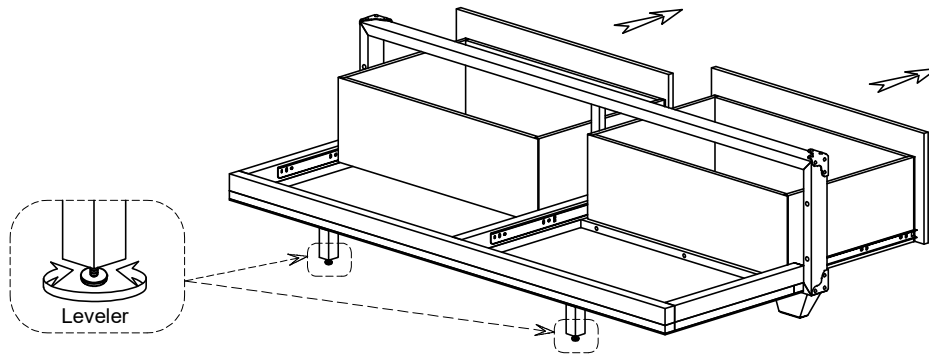

### STEP 3: REMOVE THE DRAWER



### STEP 4: HEADBOARD - FOOTBOARD - SIDE RAIL ASSEMBLY

4 PLACES

<b>A</b>		8 pcs
<b>B</b>		8 pcs
<b>C</b>		8 pcs
<b>D</b>		1 pc

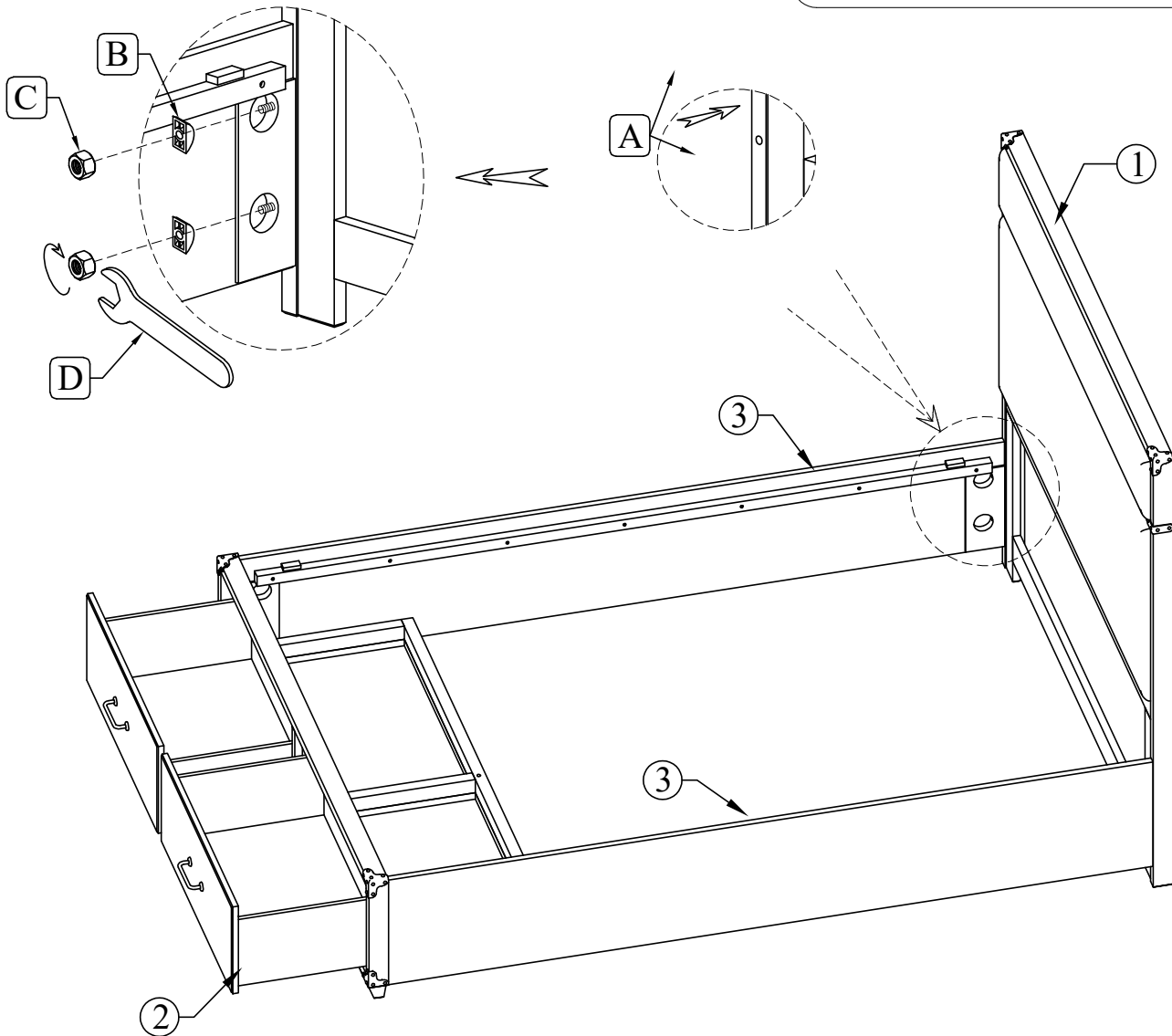

## STEP 5: SUPPORT LEG ASSEMBLY

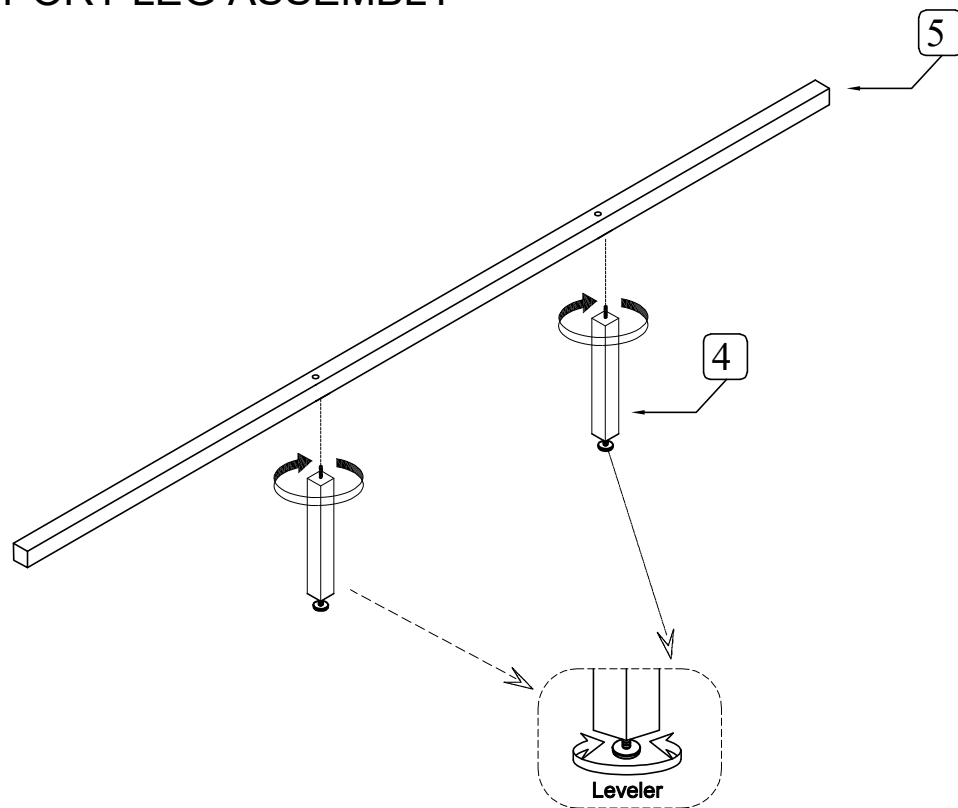

## STEP 6: SLAT ASSEMBLY

**E**



3 pcs

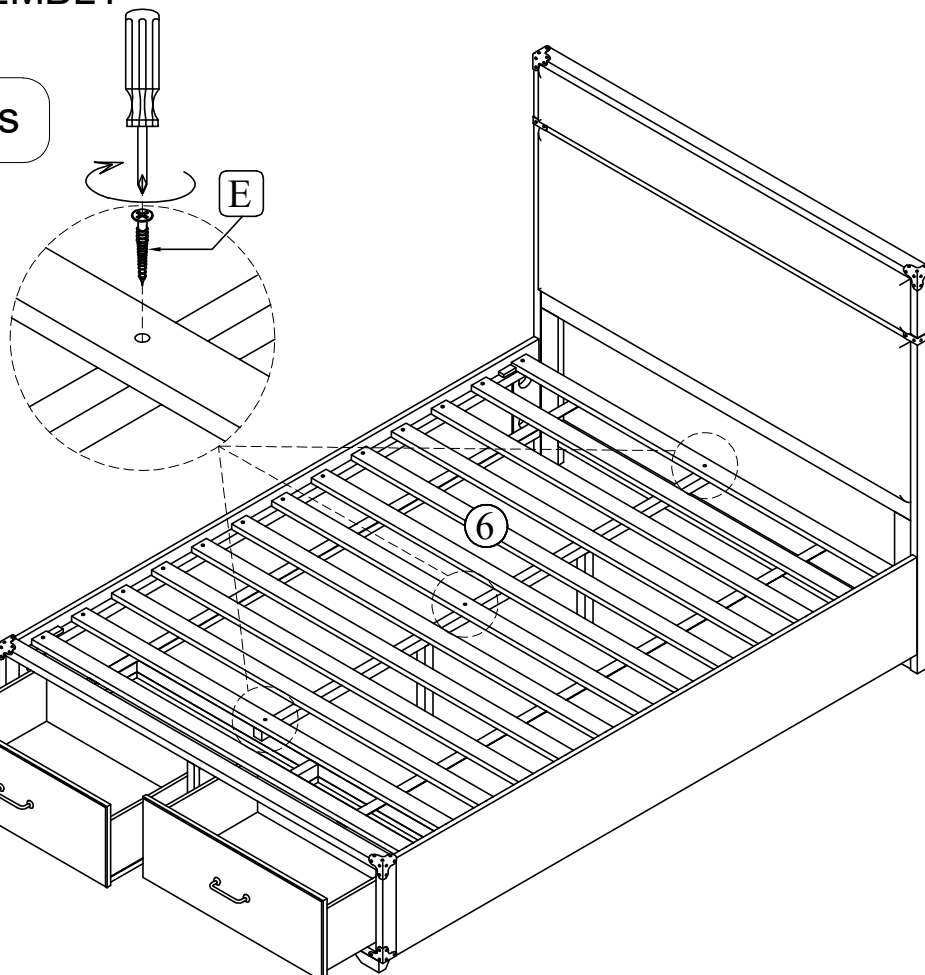

## STEP 7: SLAT ASSEMBLY

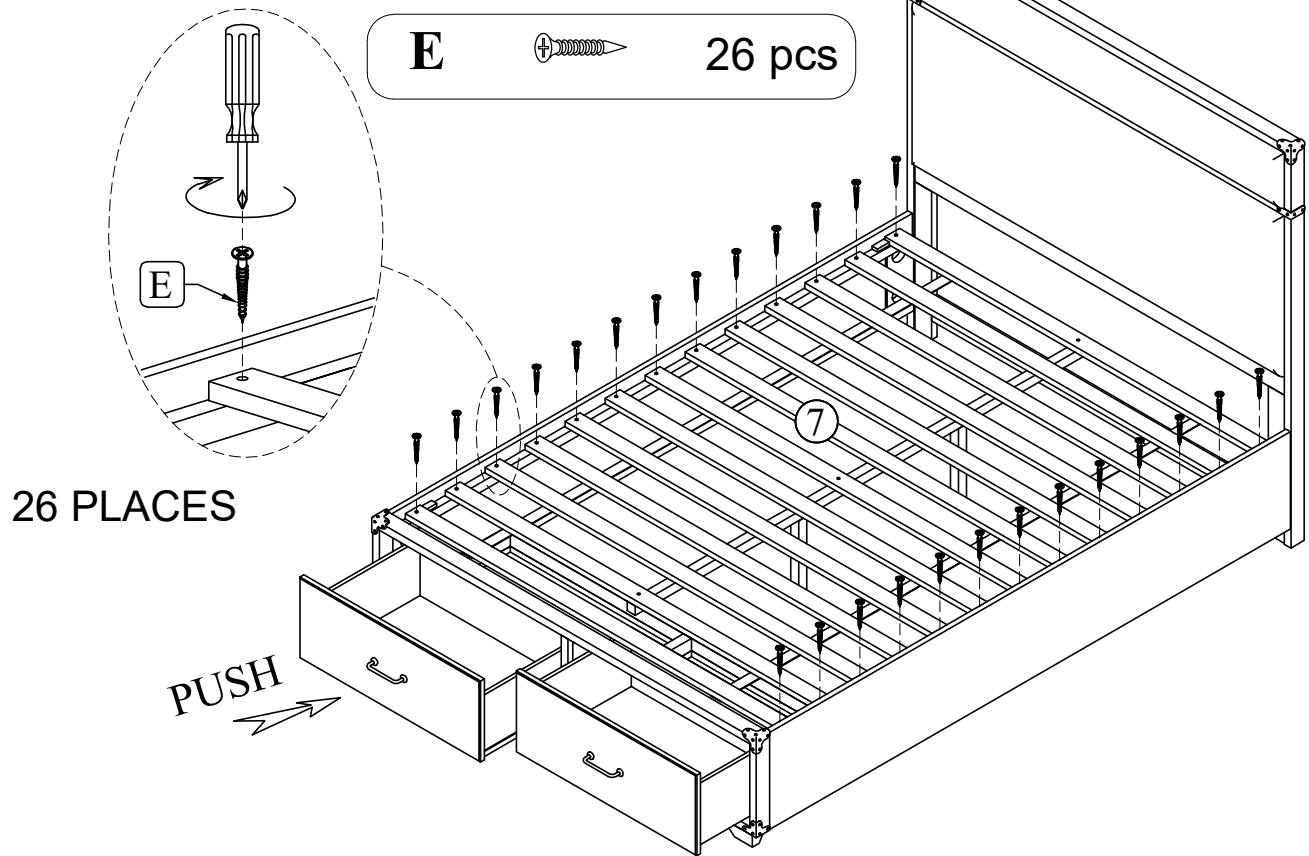

## STEP 8:

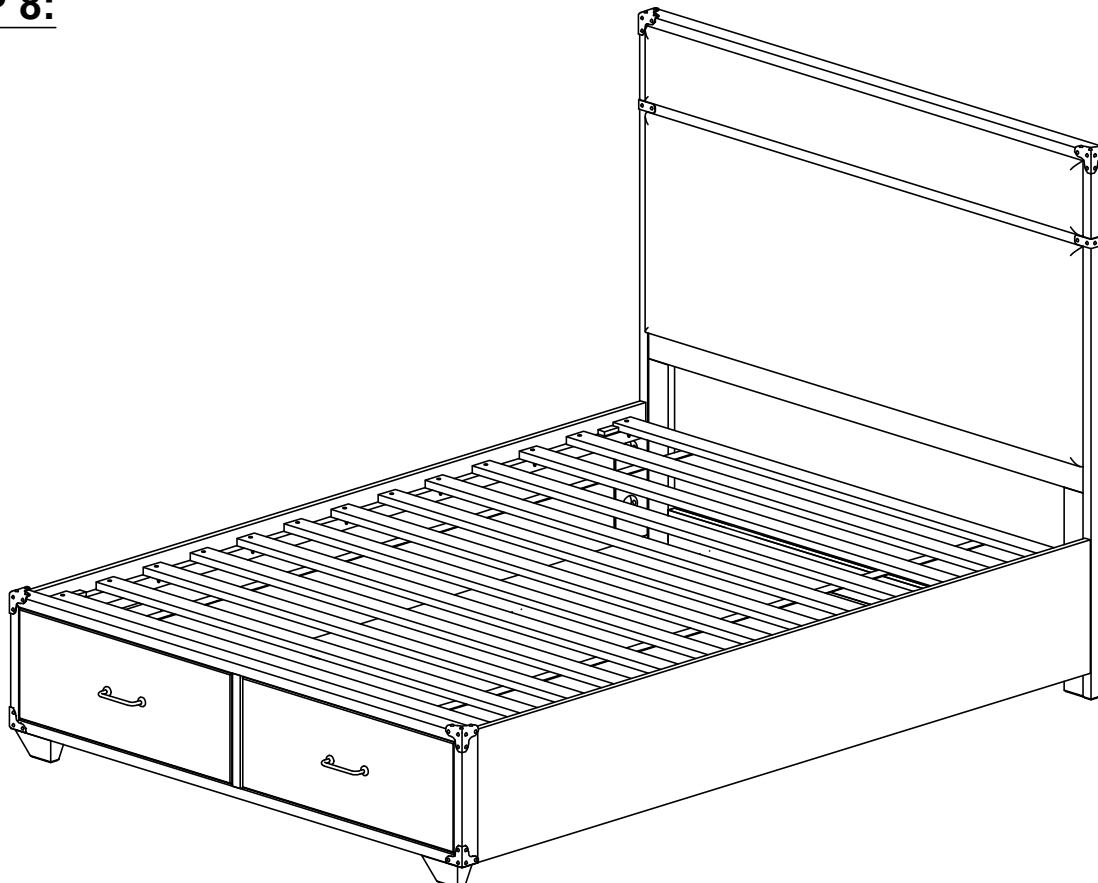

**ASSEMBLY IS COMPLETED**