

# ASSEMBLY INSTRUCTION FOR ACME FURNITURE

## MODEL#97785

Thank you for purchasing the quality product. Be sure to check all packing material carefully for small parts which may have come loose inside the carton during shipment. Separate, identify and count all parts and metal hardware. Compare with all parts are present. If any part(s) are missing or damaged, please contact your local furniture dealer. For efficient and speedy service, please indicate the model number and code letter of part(s) needed.

**\*\*\*Do not fully tighten screws until fully assembled.\*\*\***

## SHOE CABINET

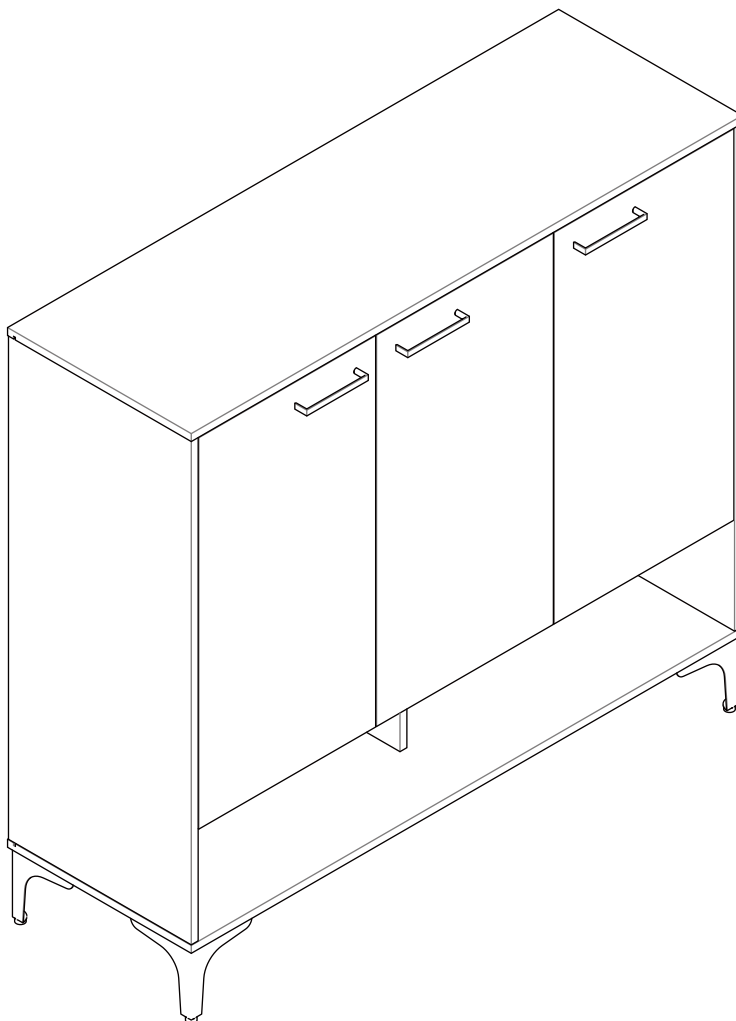

### DIMENSIONS

Width - 47.24"  
Depth - 16.73"  
Height - 44.08"

## PARTS LIST

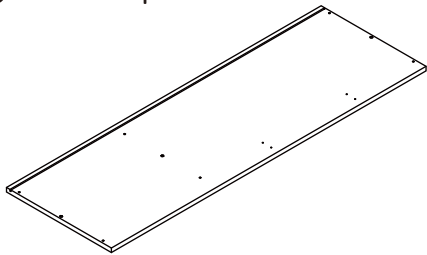
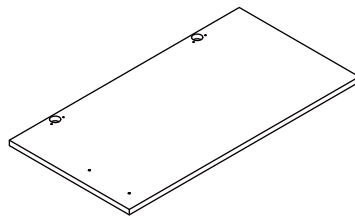
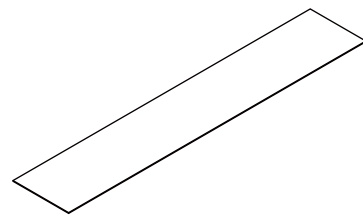
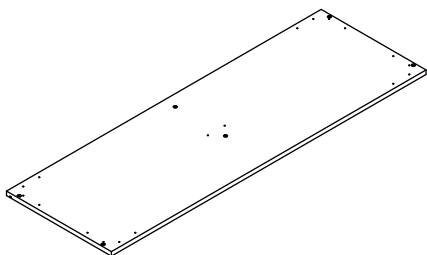
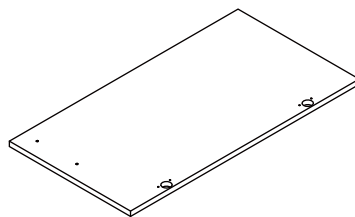
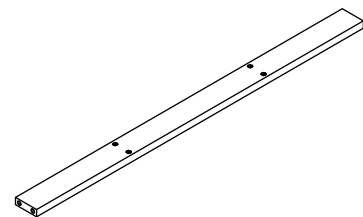
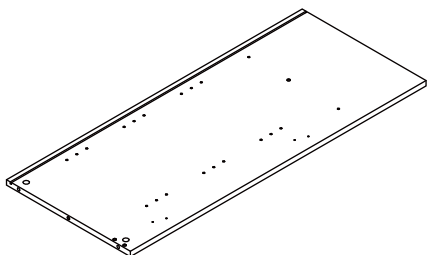
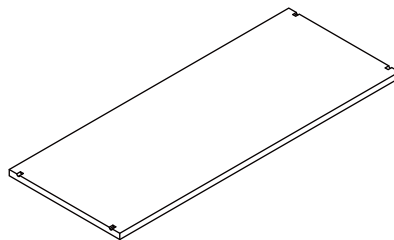
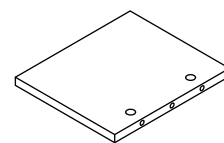
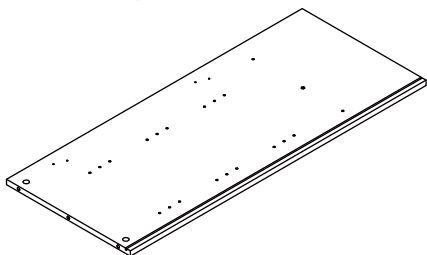
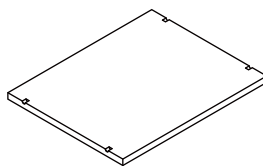
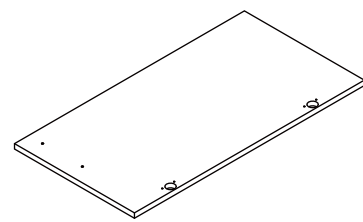
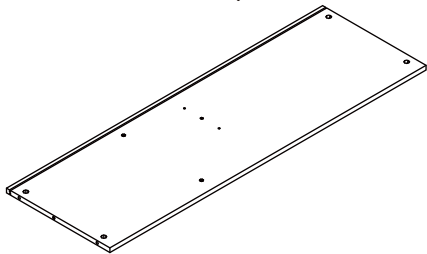
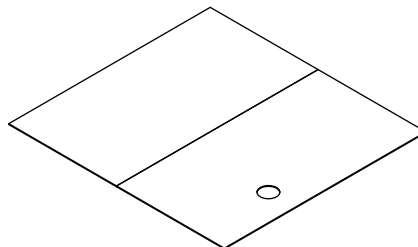
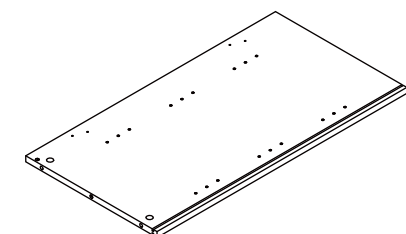
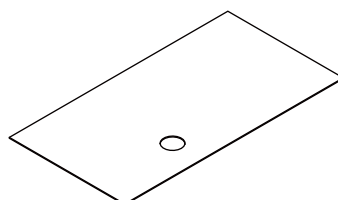
**A** X1 Top**G** X1 Left door**M** X1 Bottom back**B** X1 Bottom**H** X1 Right door**N** X1 Top support**C** X1 Left side**I** X3 Large layer**O** X1 Bottom support**D** X1 Right side**J** X3 Small layer**P** X1 Middle door**E** X1 Middle top**K** X1 Left back**F** X1 Middle**L** X1 Right back

# HARDWARE LIST

① X12 Cam bolt 7\*35\*12.5mm



② X12 Cam lock 15\*12mm



③ X9 Dowel 8\*30mm



④ X4 Wood screw 8#\*7/8"



⑤ X8 Coarse screw 7\*11\*50mm

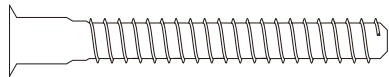

⑥ X24 Shelf pin 4.9\*16mm



⑦ X3 Handle

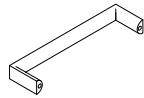

⑧ X6 Handle screw 8/32\*19mm



⑨ X6 Hinge ø26mm\*insert

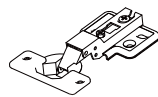

⑩ X24 Hinge screw 6#\*1/2"

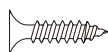

⑪ X6 Fixative plate

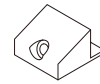

⑫ X6 Wood screw 3\*19mm



⑬ X4 Foot

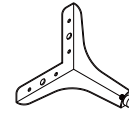

⑭ X16 T-head screw 4\*12mm

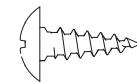

⑮ X1 Support foot

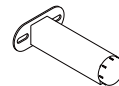

⑯ X2 T-head screw 8#\*1/2"

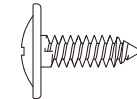

⑰ X2 Vent cap 60mm\*66mm\*3mm



⑱ X1 Glue



⑲ X1 Allen wrench

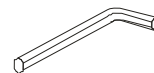

## Attention

Some number parts listed on the instruction sheet may not be in parts bag as they may already be assembled. Carefully check parts and packing materials prior to ordering replacements.

# ASSEMBLY INSTRUCTIONS

Step 1.

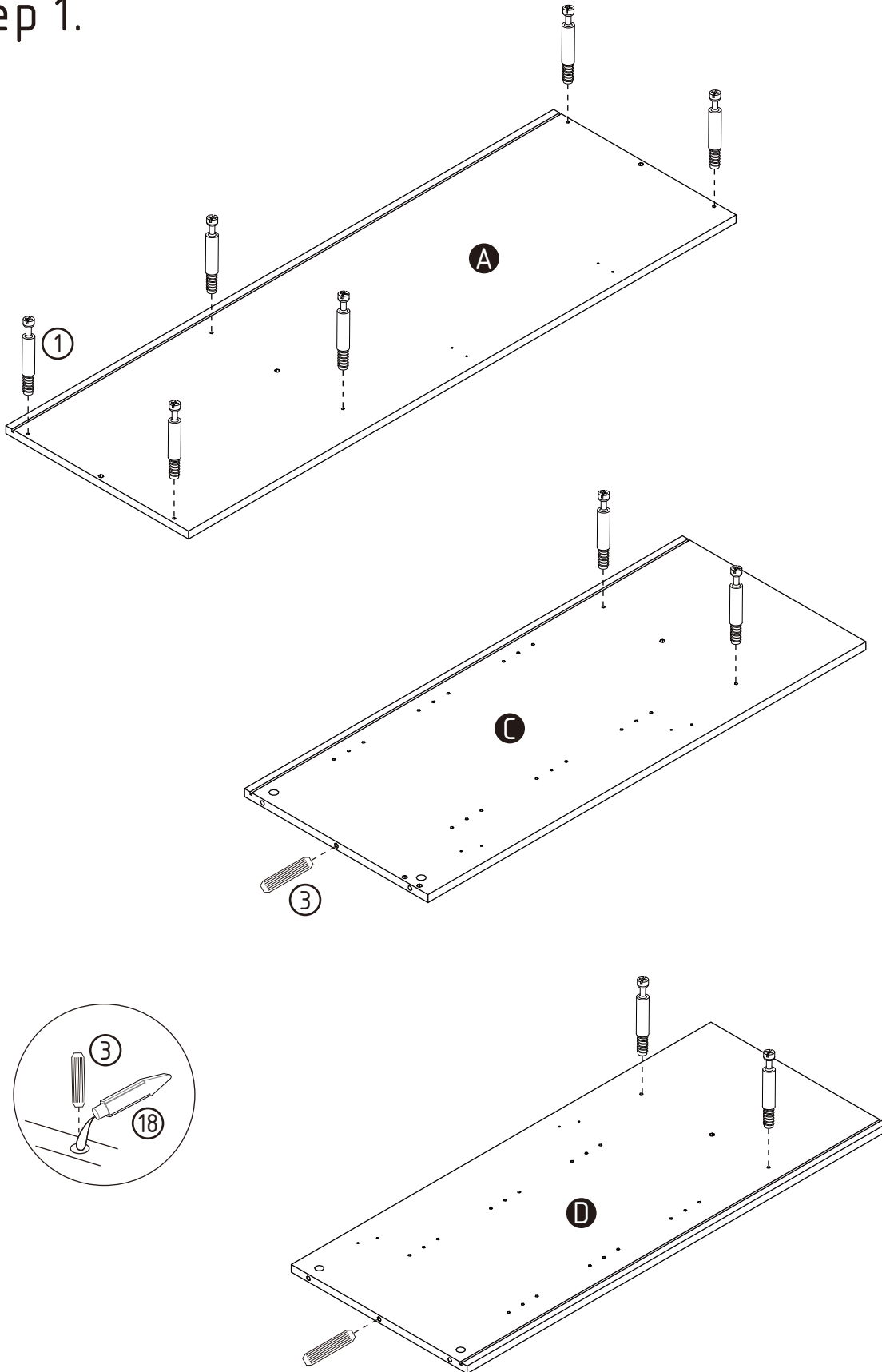

# ASSEMBLY INSTRUCTIONS

Step 2.

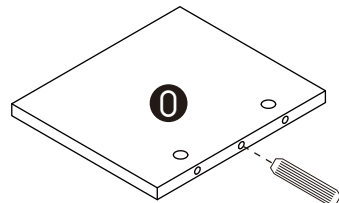
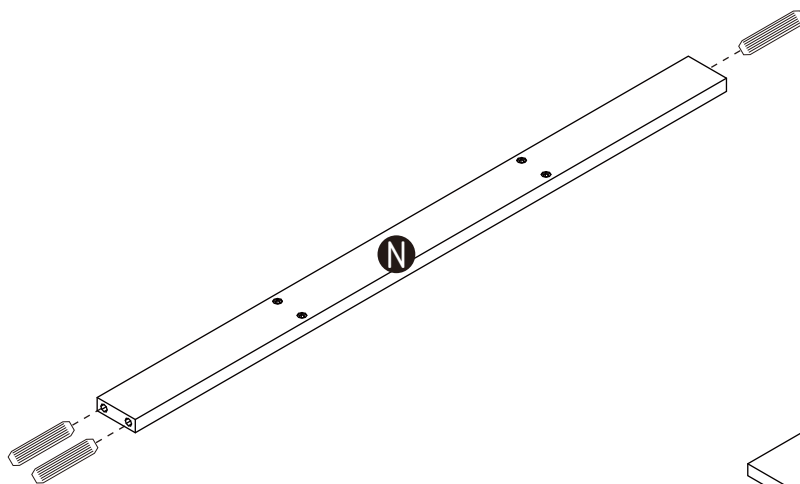
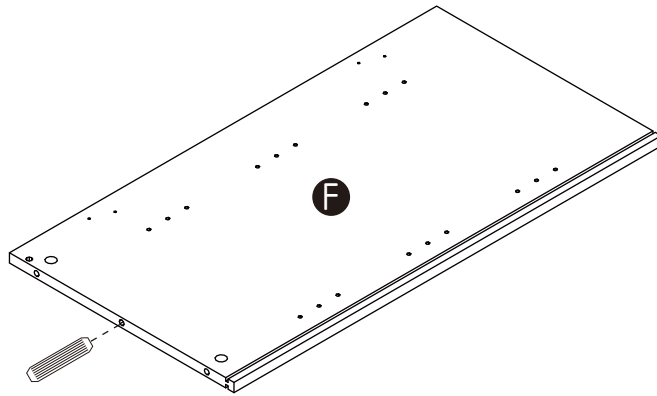
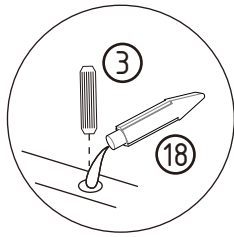
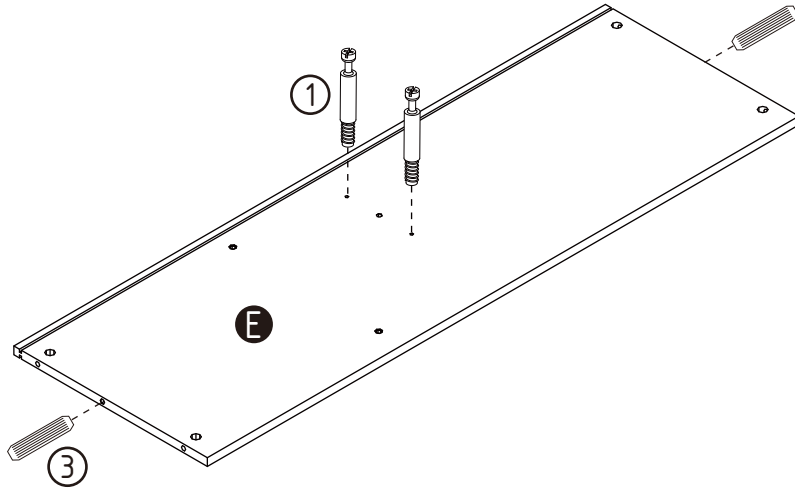

# ASSEMBLY INSTRUCTIONS

## Step 3.

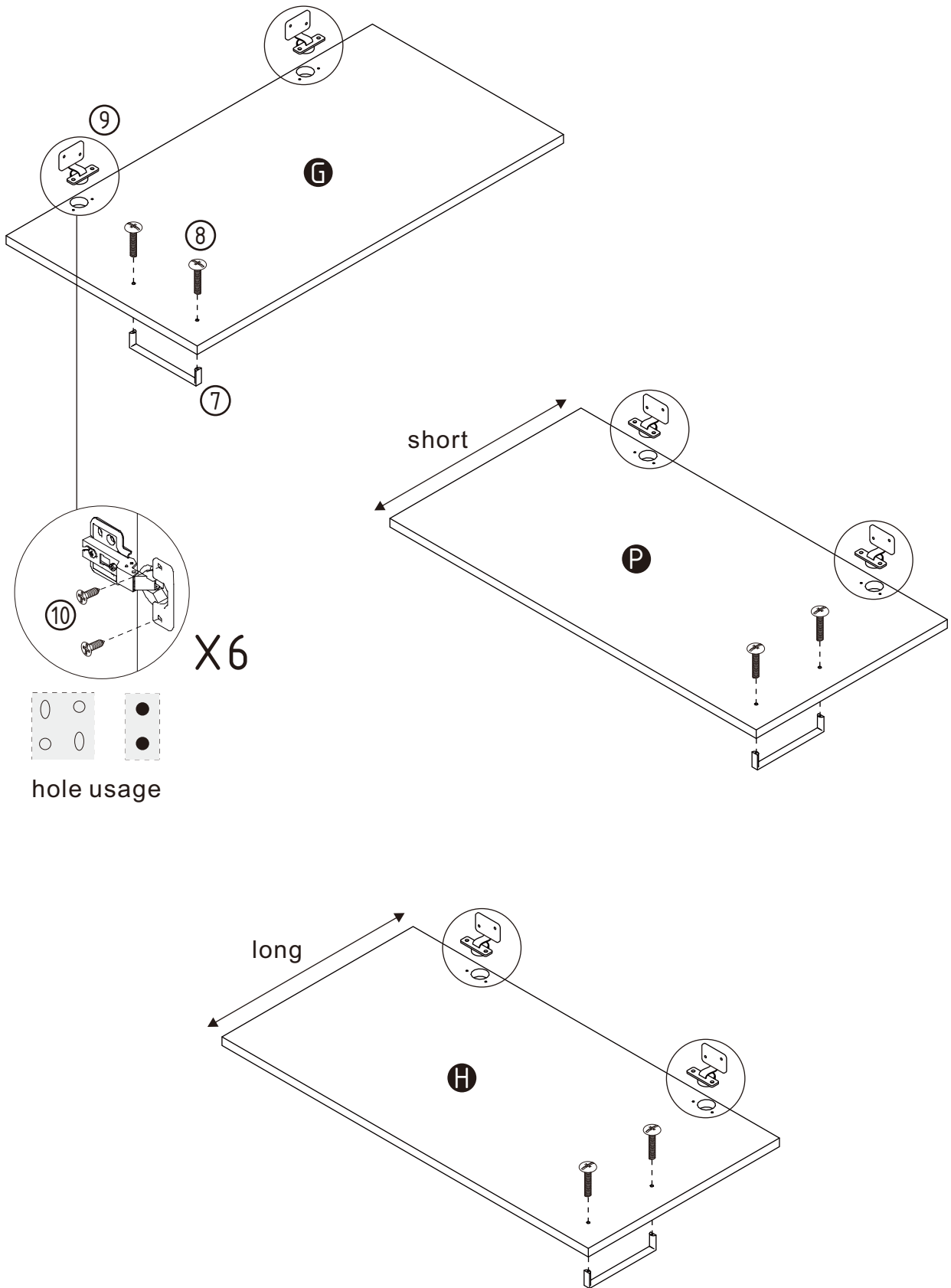

# ASSEMBLY INSTRUCTIONS

Step 4.

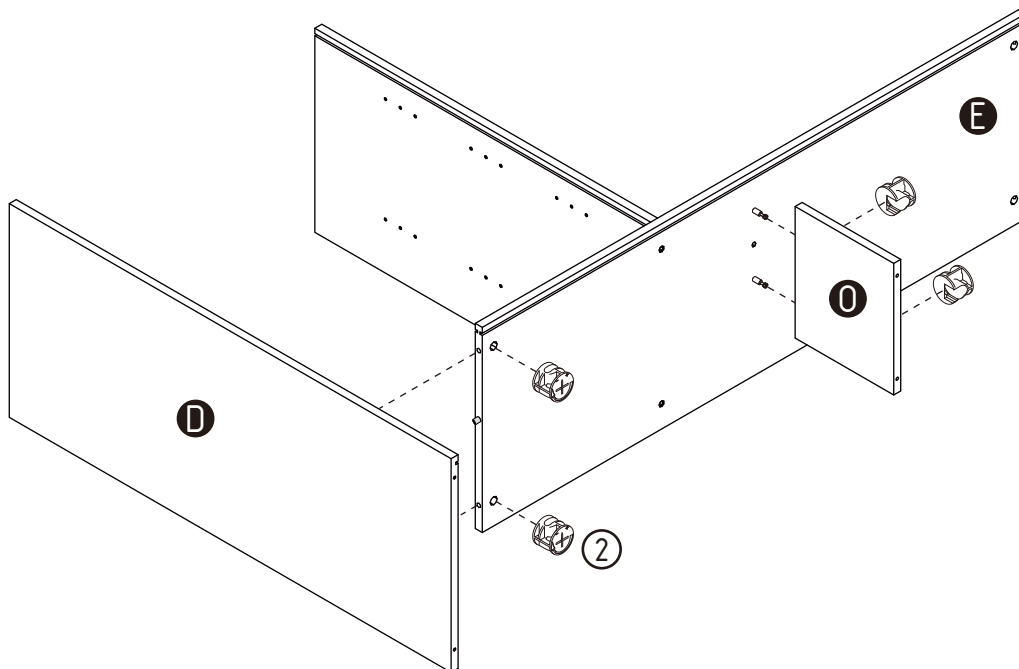
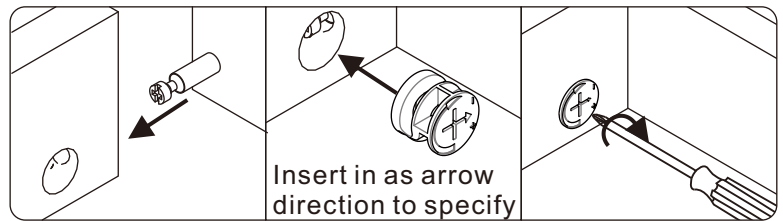
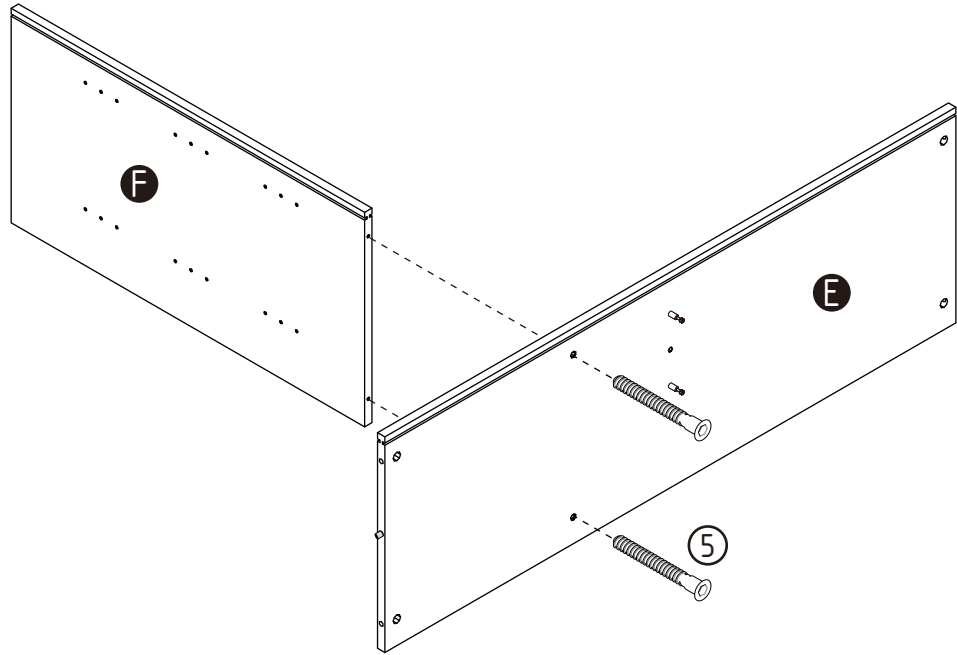

# ASSEMBLY INSTRUCTIONS

## Step 5.

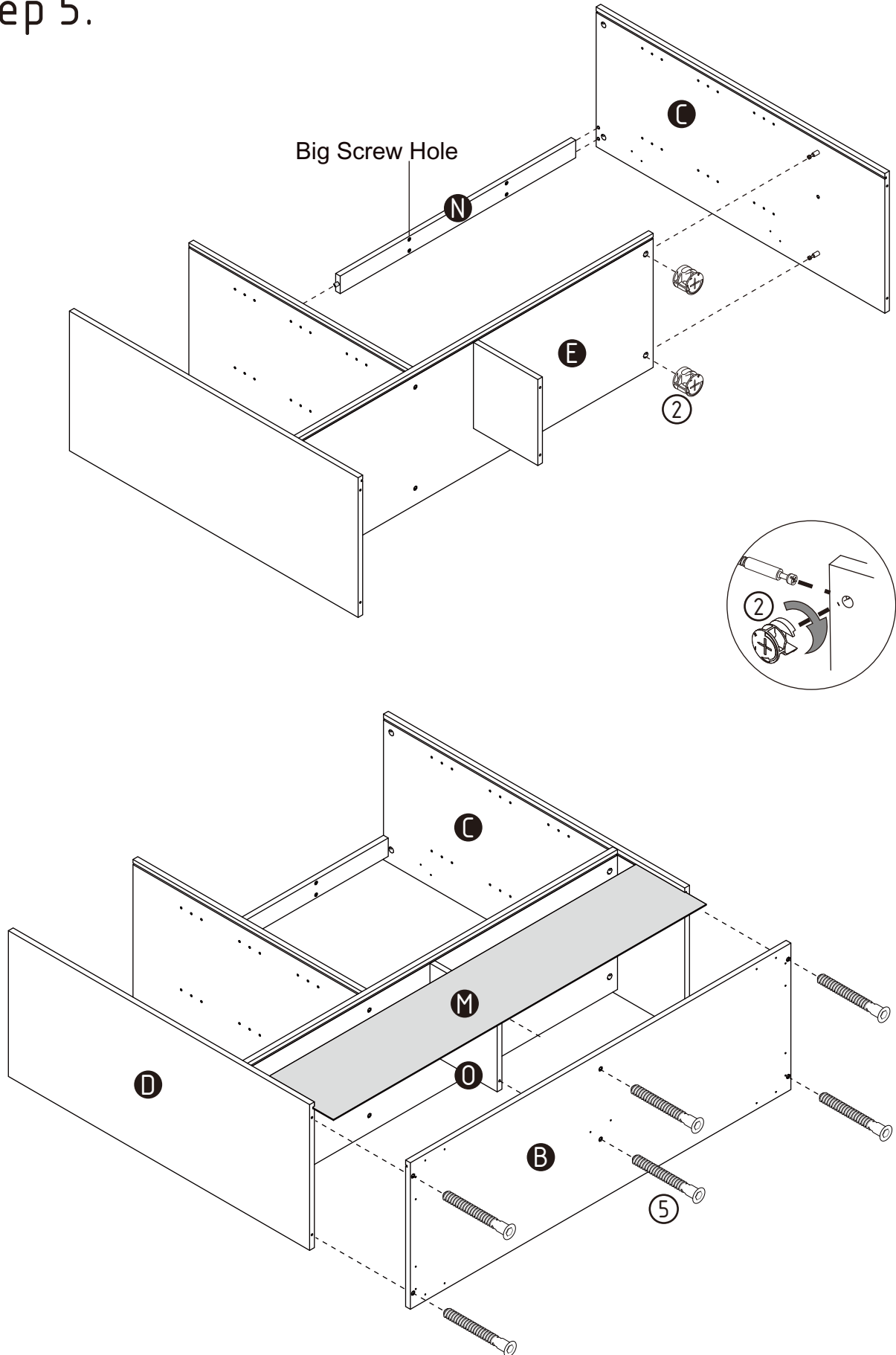



# ASSEMBLY INSTRUCTIONS

Step 6.

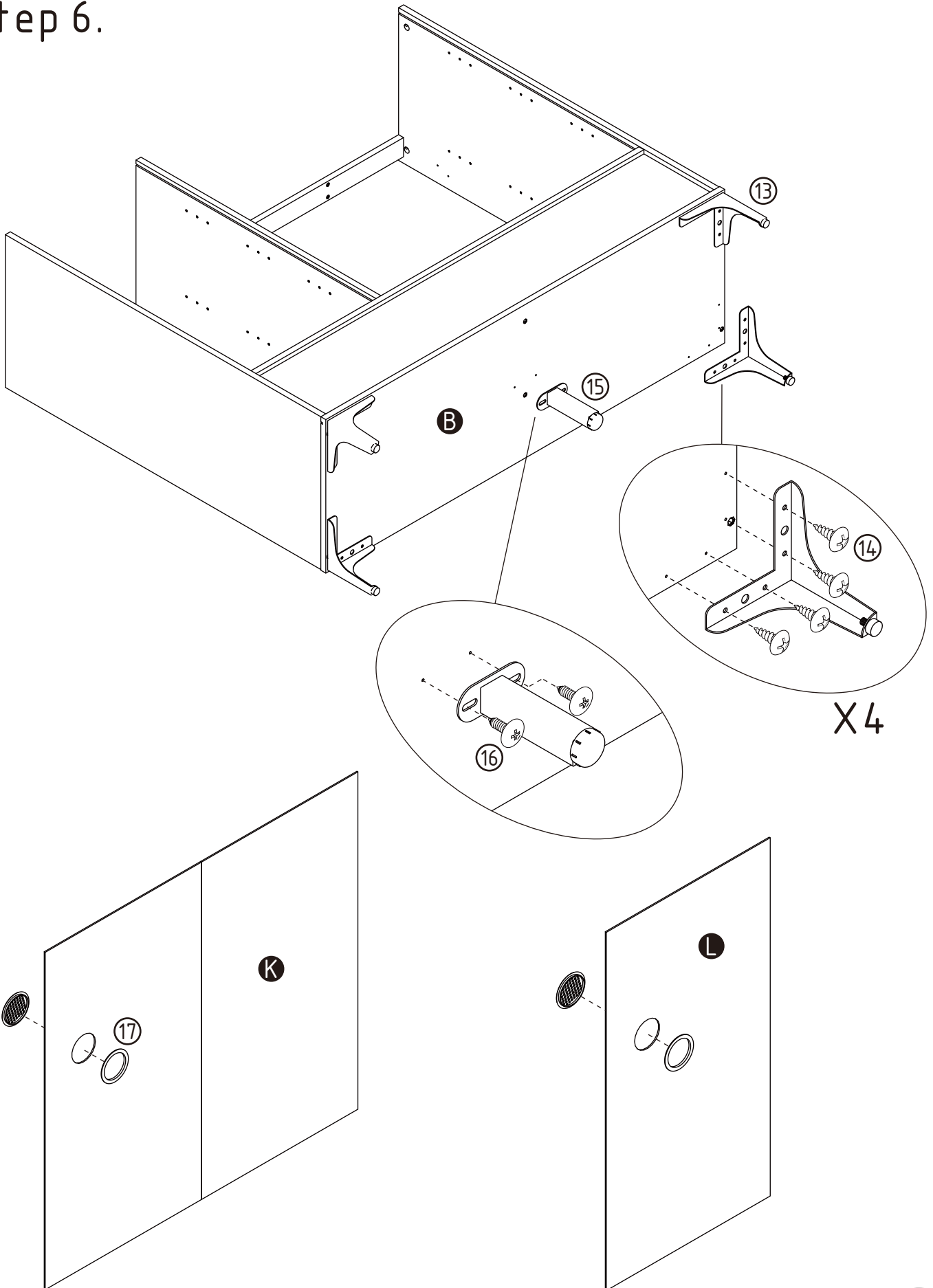

# ASSEMBLY INSTRUCTIONS

Step 7.

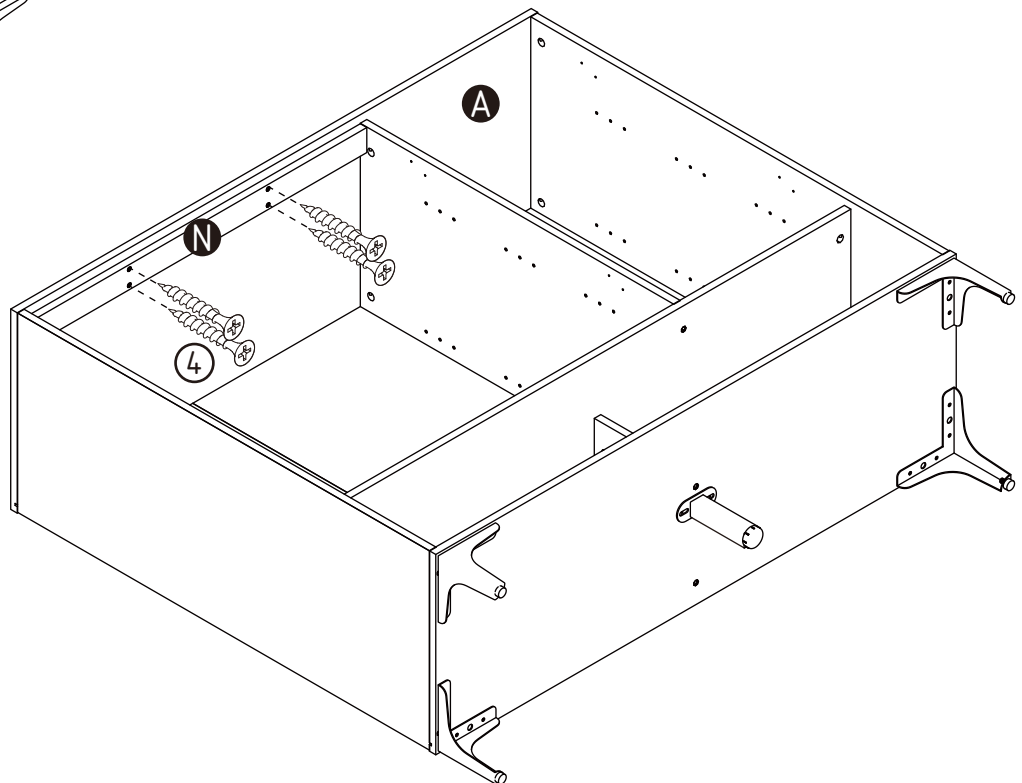
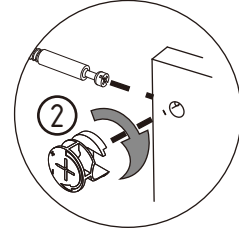
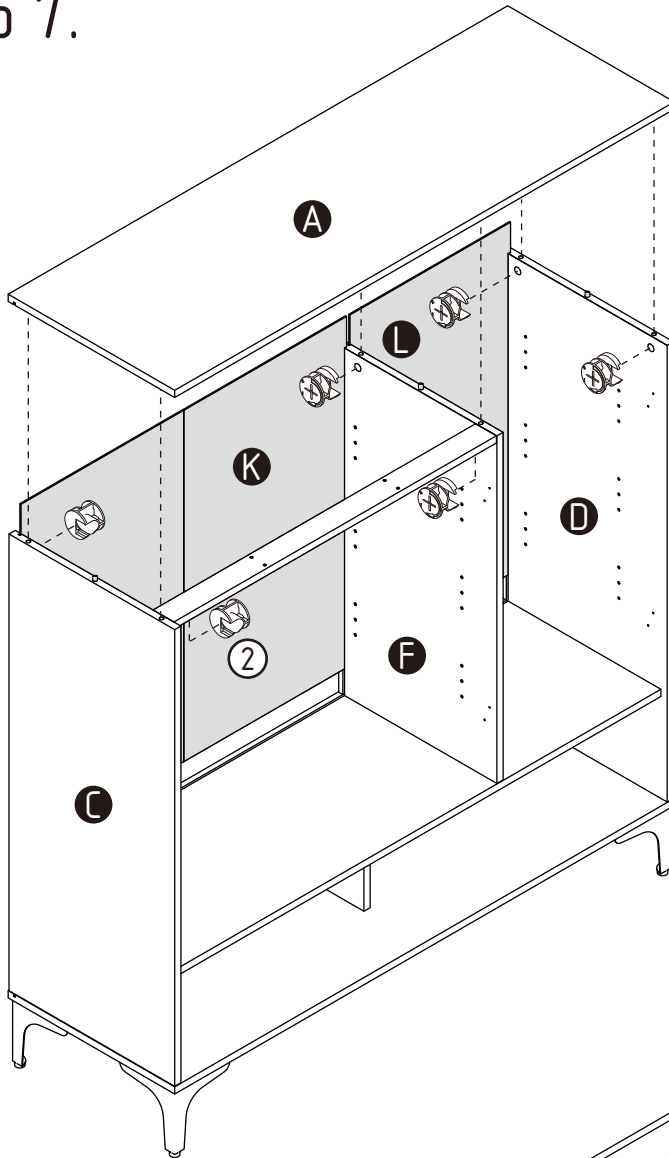

# ASSEMBLY INSTRUCTIONS

Step 8.

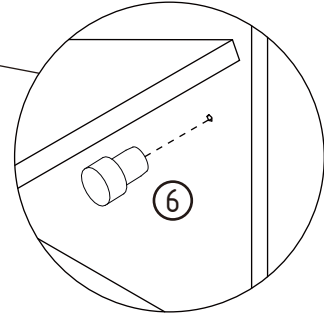
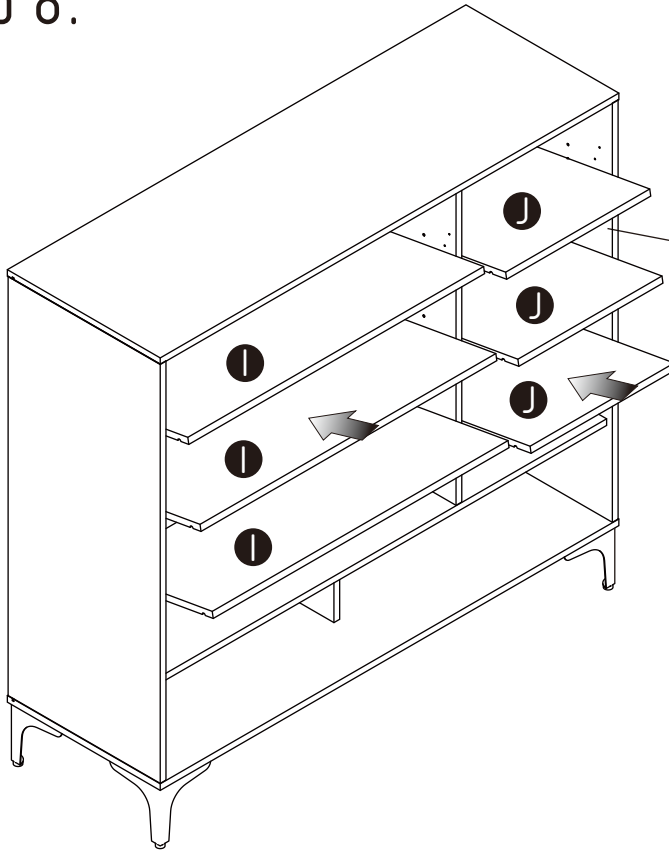

X24

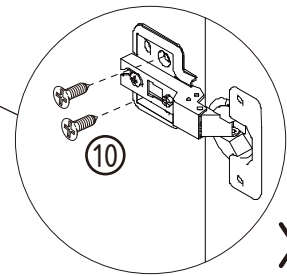
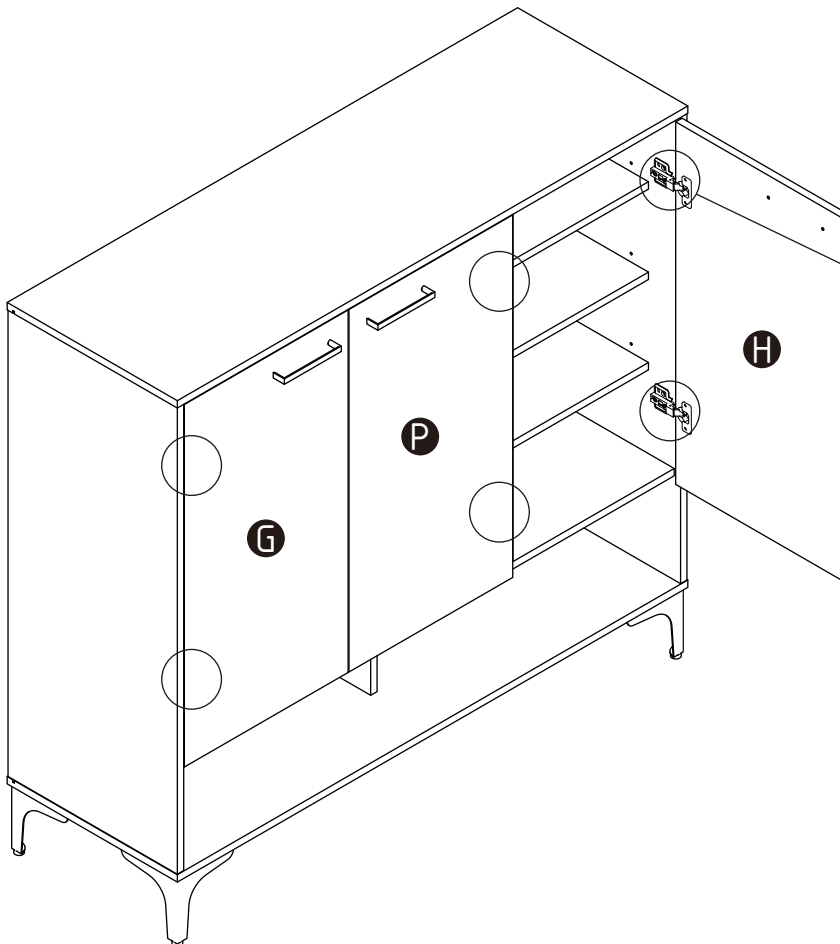

X6



hole usage

# ASSEMBLY INSTRUCTIONS

Step 9.

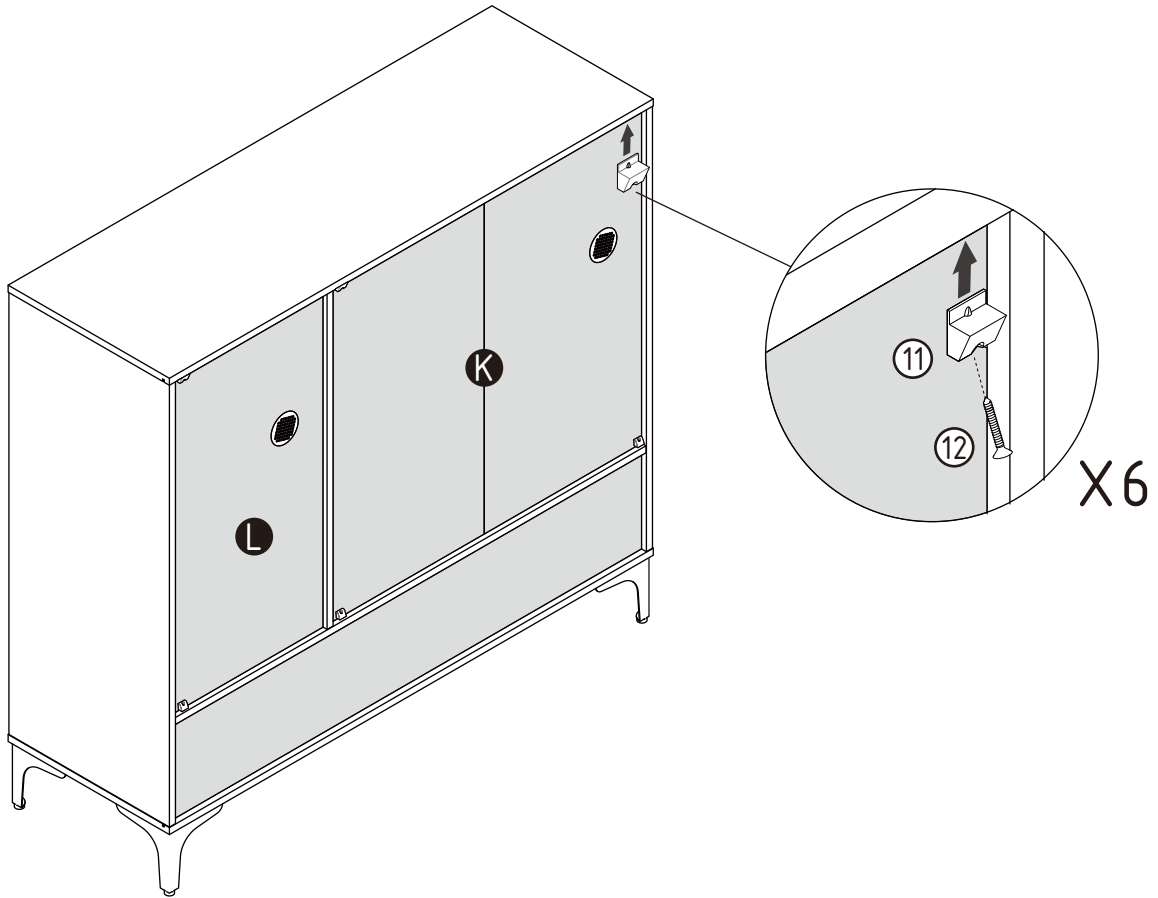

## ASSEMBLY IS COMPLETED.

Make sure the product is rested on a flat surface and does not feel loose or wobbly. If it does, double check that the bolts/screws are secured and properly tightened.