

ASSEMBLY INSTRUCTION

Step 1:

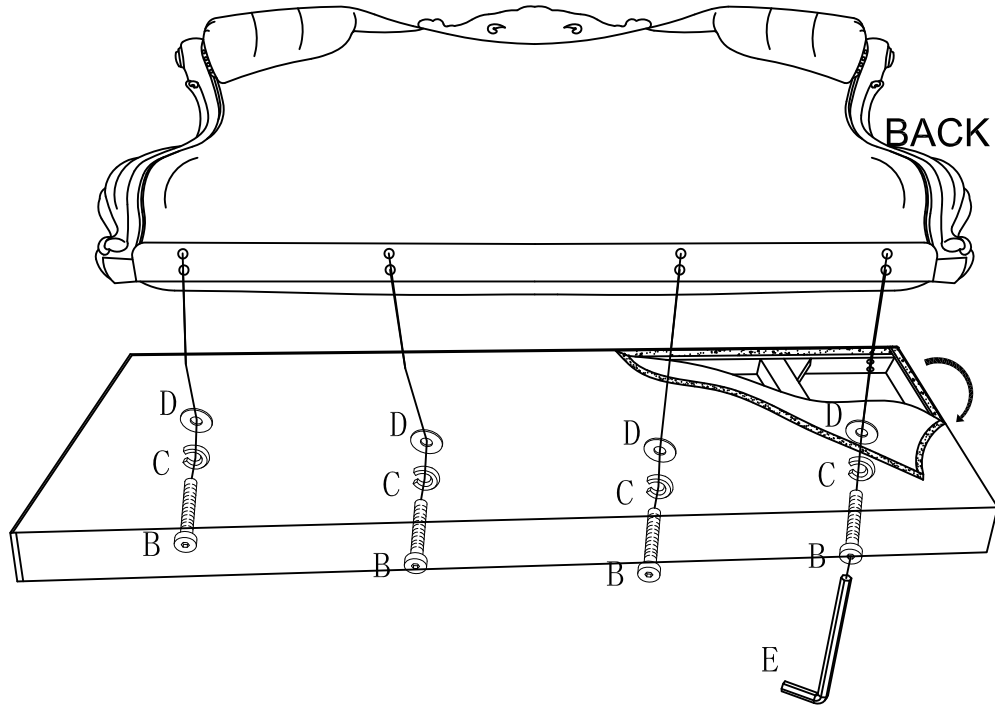

Step 2:

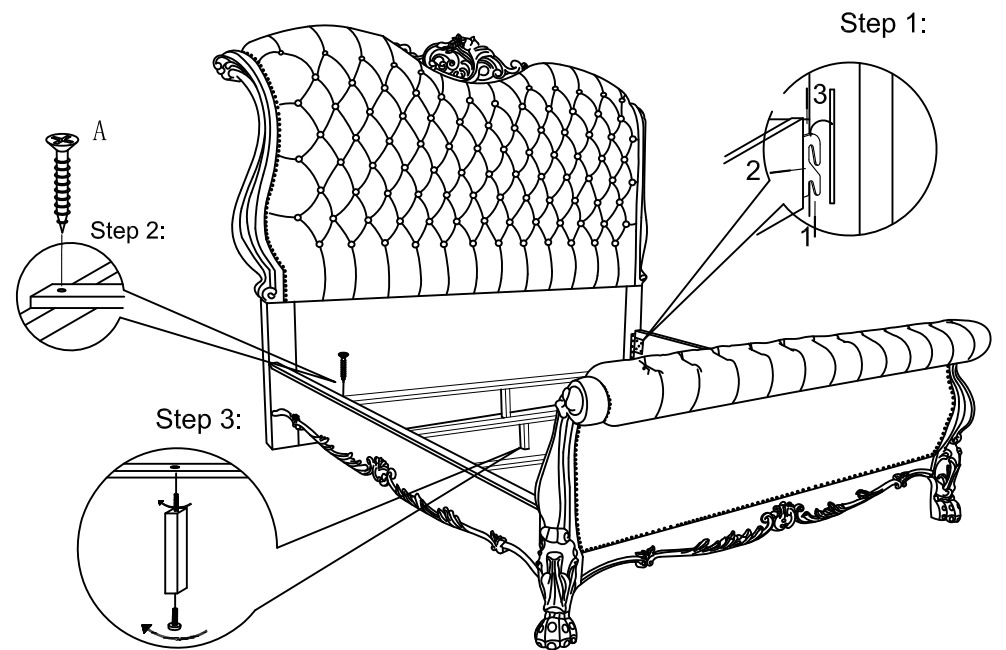

Step 1:



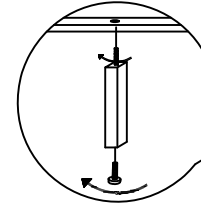

Step 3:

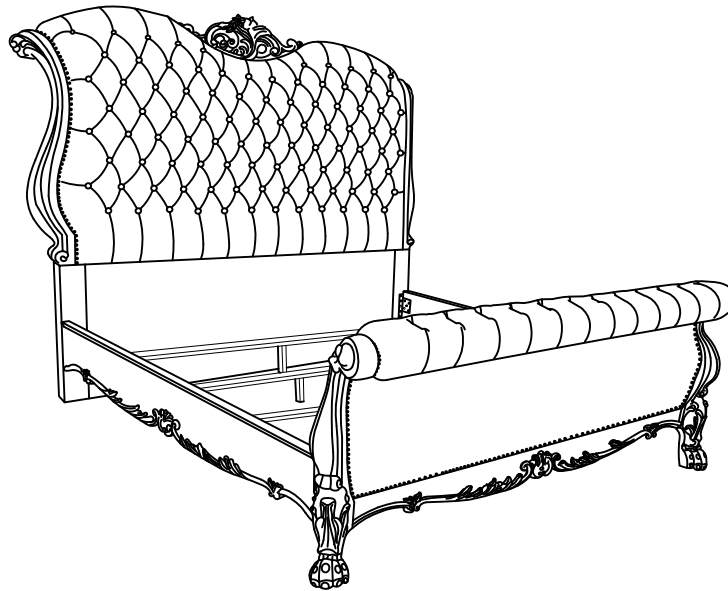

Finish :



Hardware List:

No.:	Description	Drawing	Size	Q' ty
A	wood screw		Ø8 X 1-1/2"	10
B	Bolt		Ø5/16" X2-1/4 "	8
C	Lock Washer		Ø5/16" X12mm	8
D	Flat Washer		Ø5/16" X22mm	8
E	Allen Wrench		5mmX60mm	1