

ACME

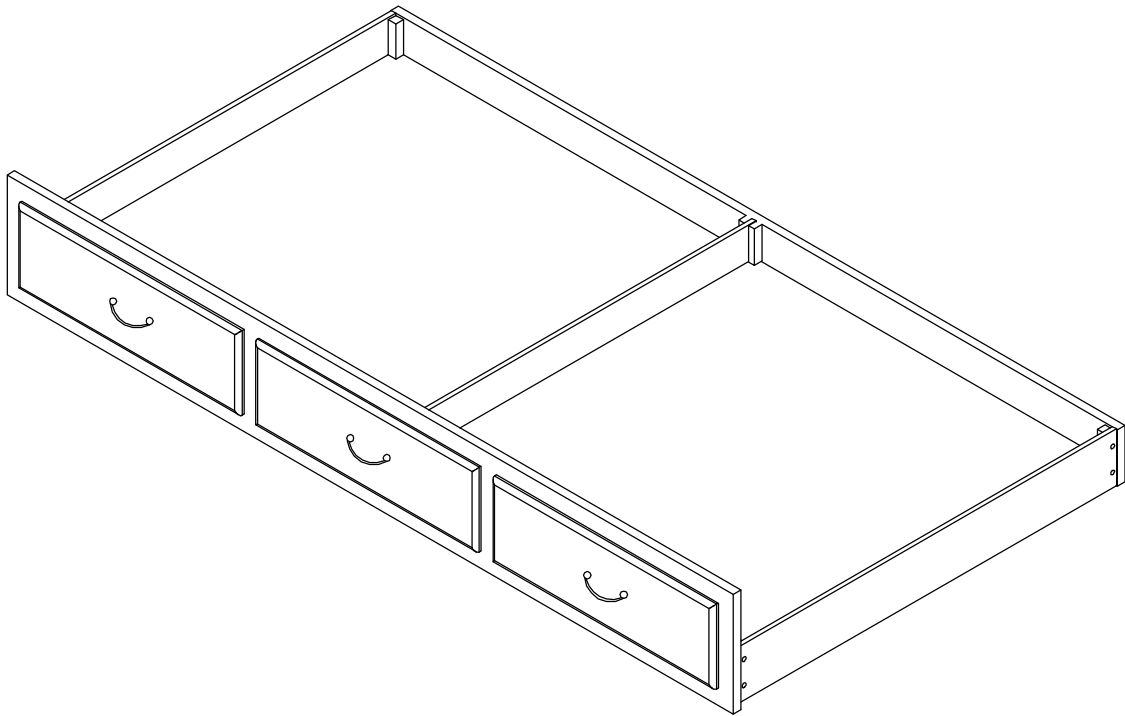





FURNITURE

ASSEMBLY INSTRUCTIONS
Item No: #39097 & #39102









Do not tighten screws until each step is completed.

PARTS LIST

No	Diagram	Description	Q'ty
1		FRONT PANEL	1 pc
2		BACK PANEL	1 pc
3		SIDE PANEL	2 pcs
4		BOTTOM PANEL (4pcs=1set)	1 Set
5		SLATS	3 pcs
6		PARTITION	1 pc

HARDWARE LIST

No	Diagram	Description	Q'ty
A		Bolt - 6.3 x 30 (mm)	8 pcs
B		Screw - 4 x 30(mm)	6 pcs
C		Screw - 4 x 20(mm)	8 pcs
D		Wheel	4 pcs
E		Dowel - 10 x 40(mm)	2 pcs
F		Allen Wrench	1 pc

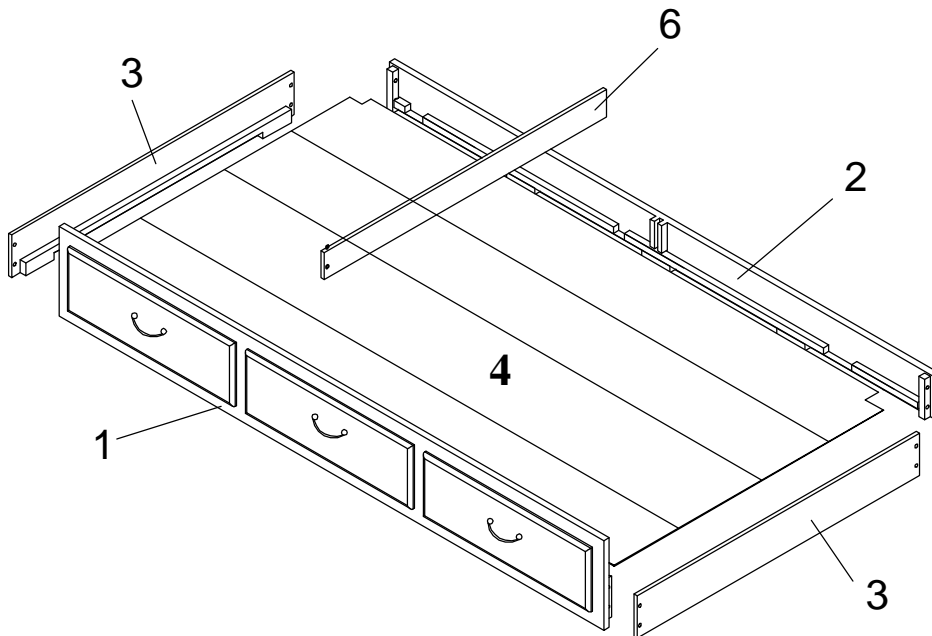

STEP 1:

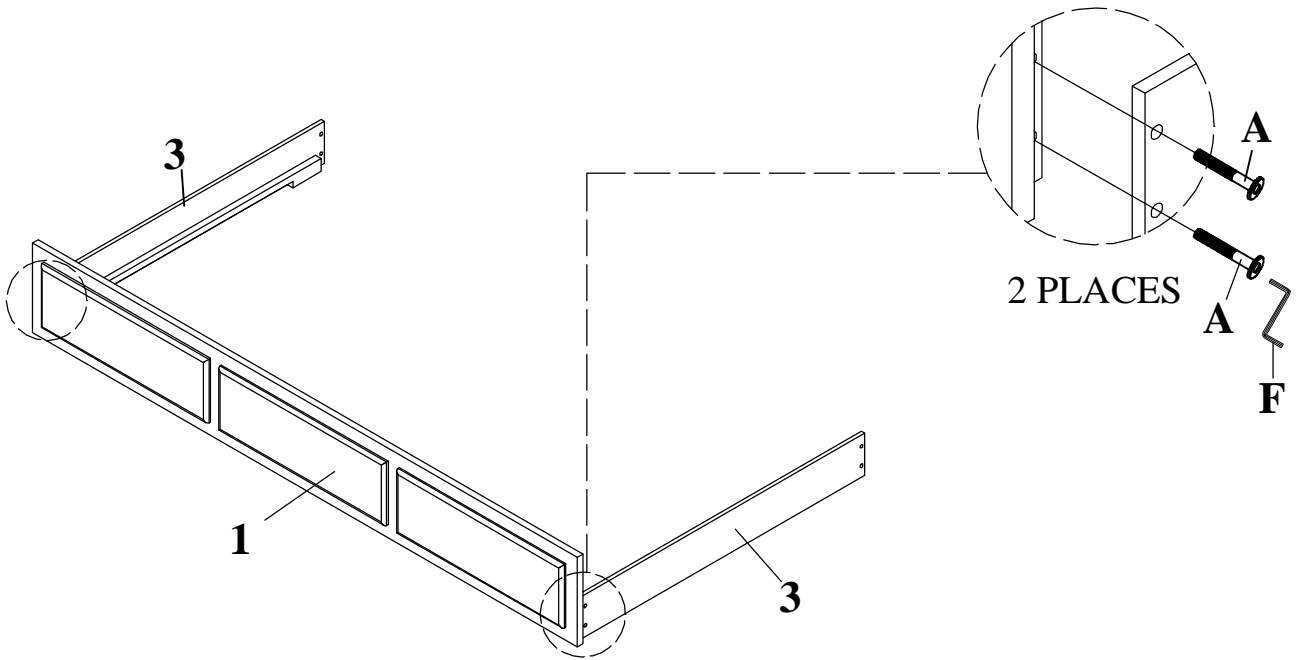

STEP 2:

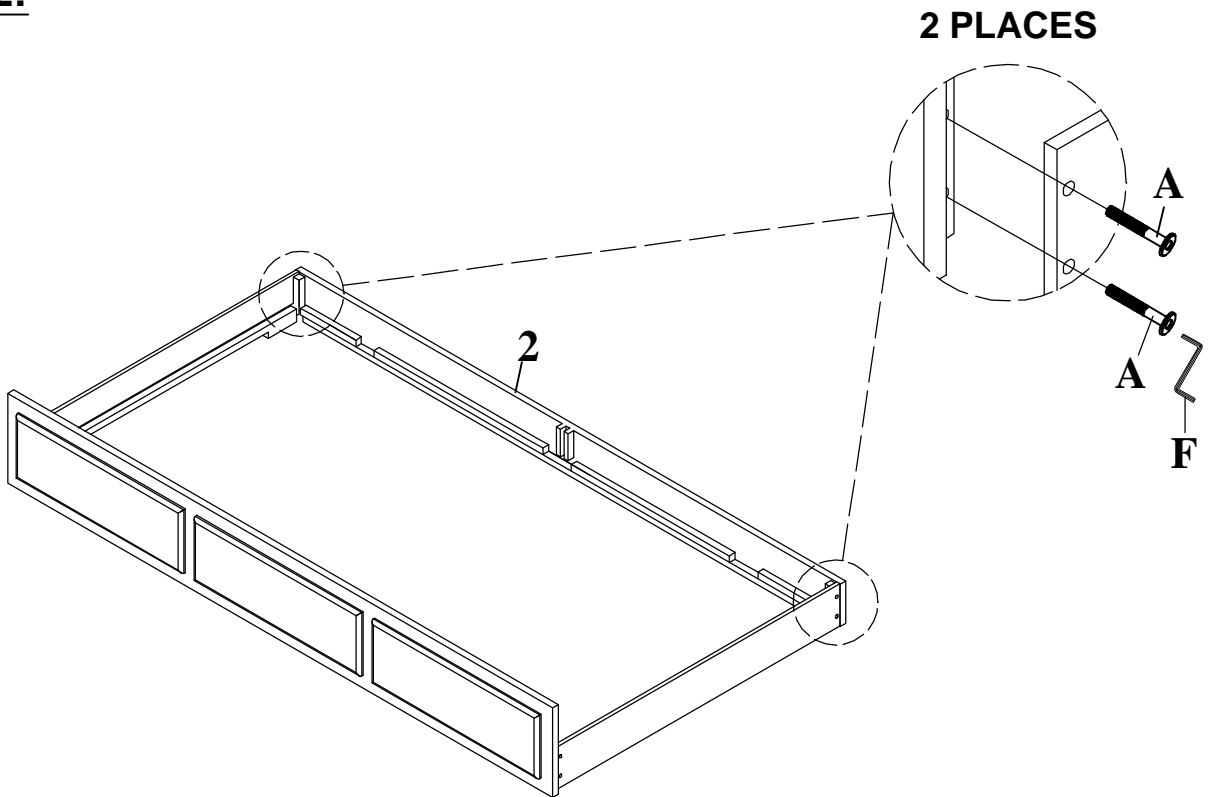

STEP 3:

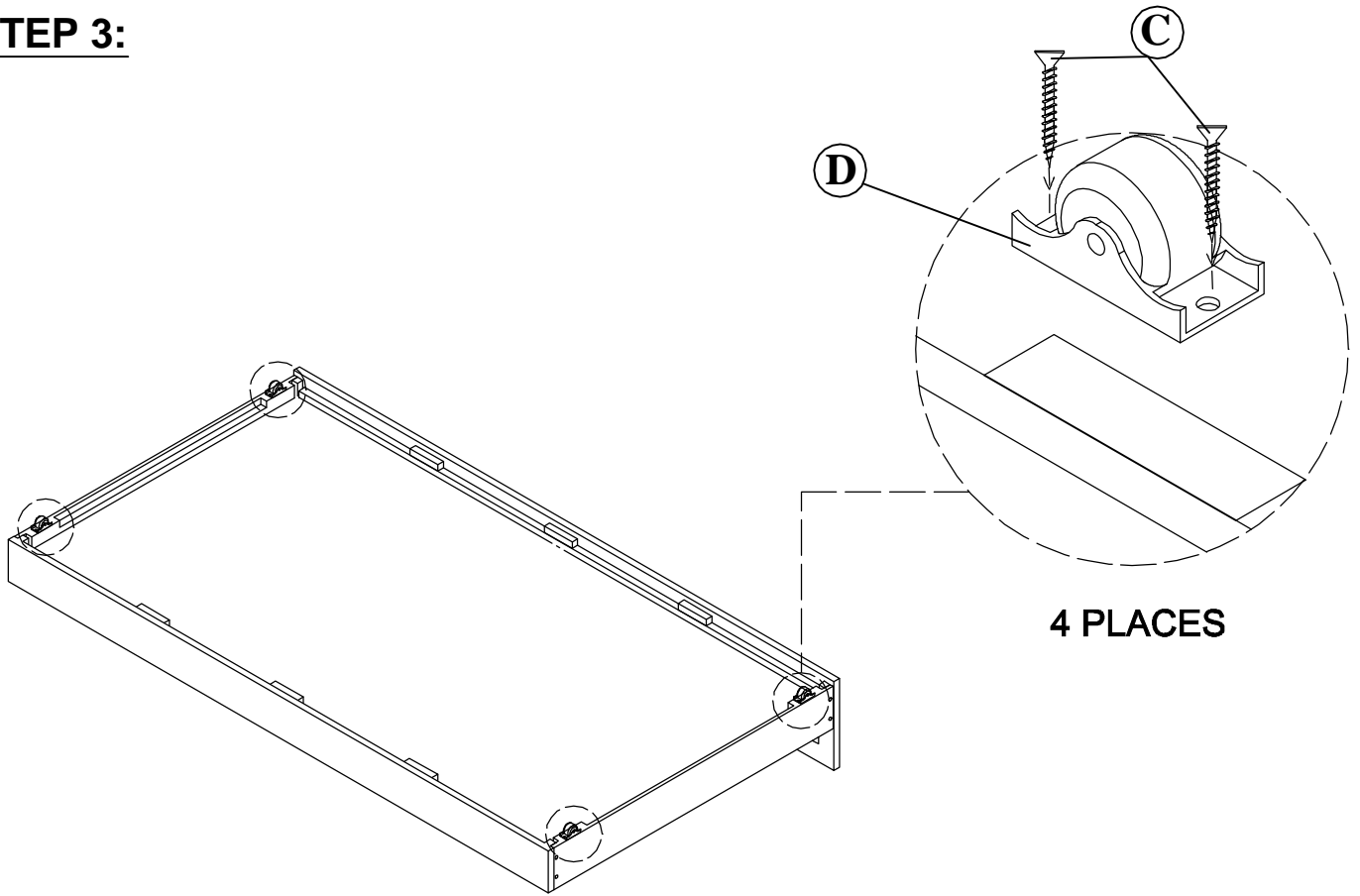

STEP 4:

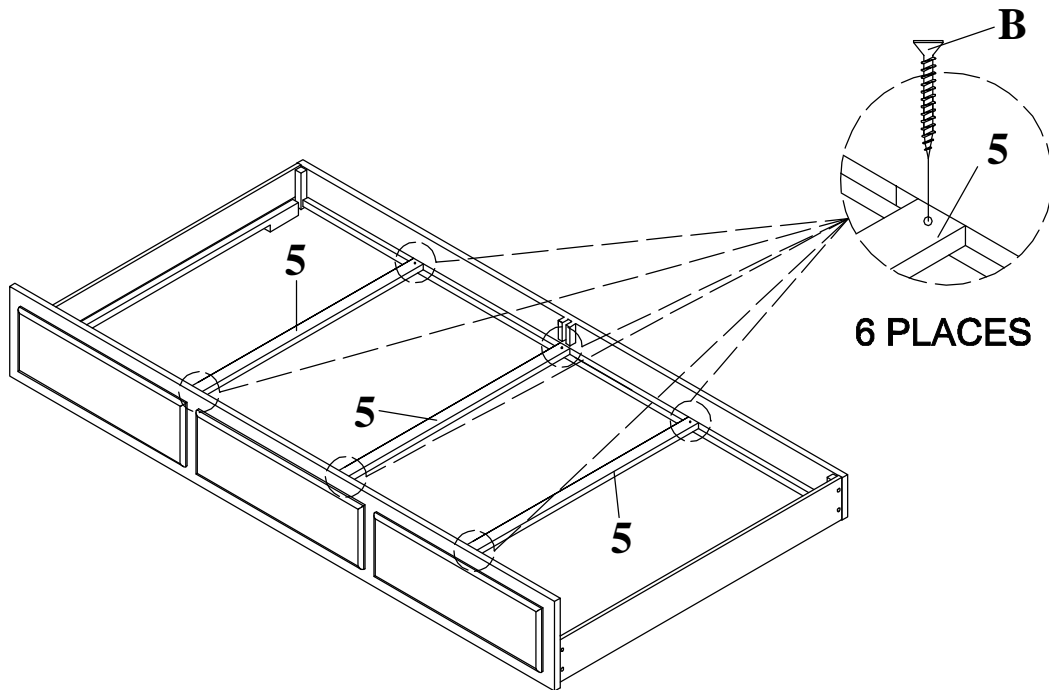

STEP 5:

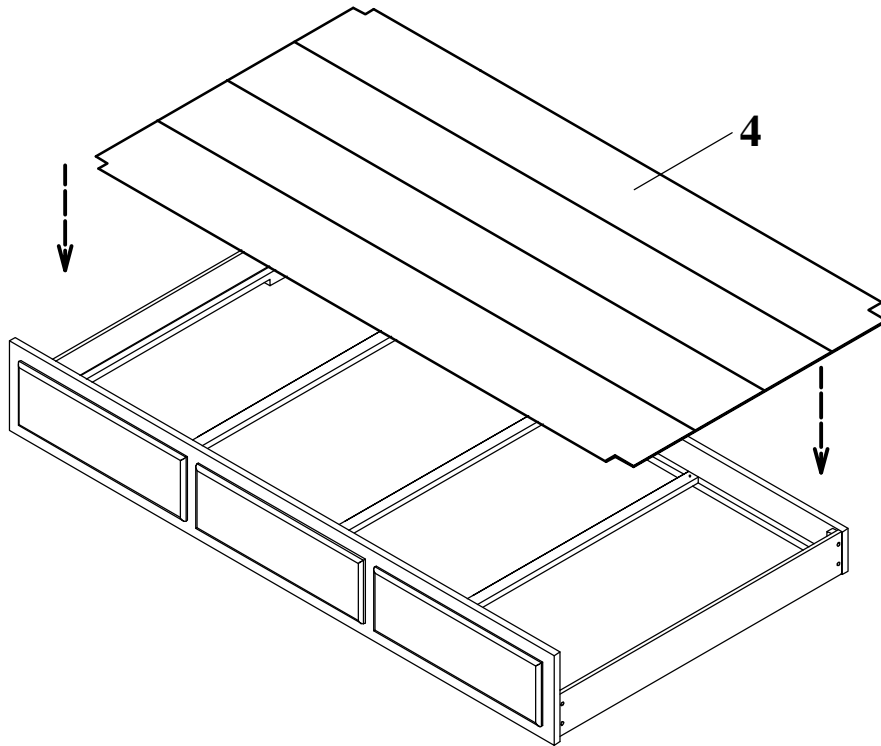

STEP 6:

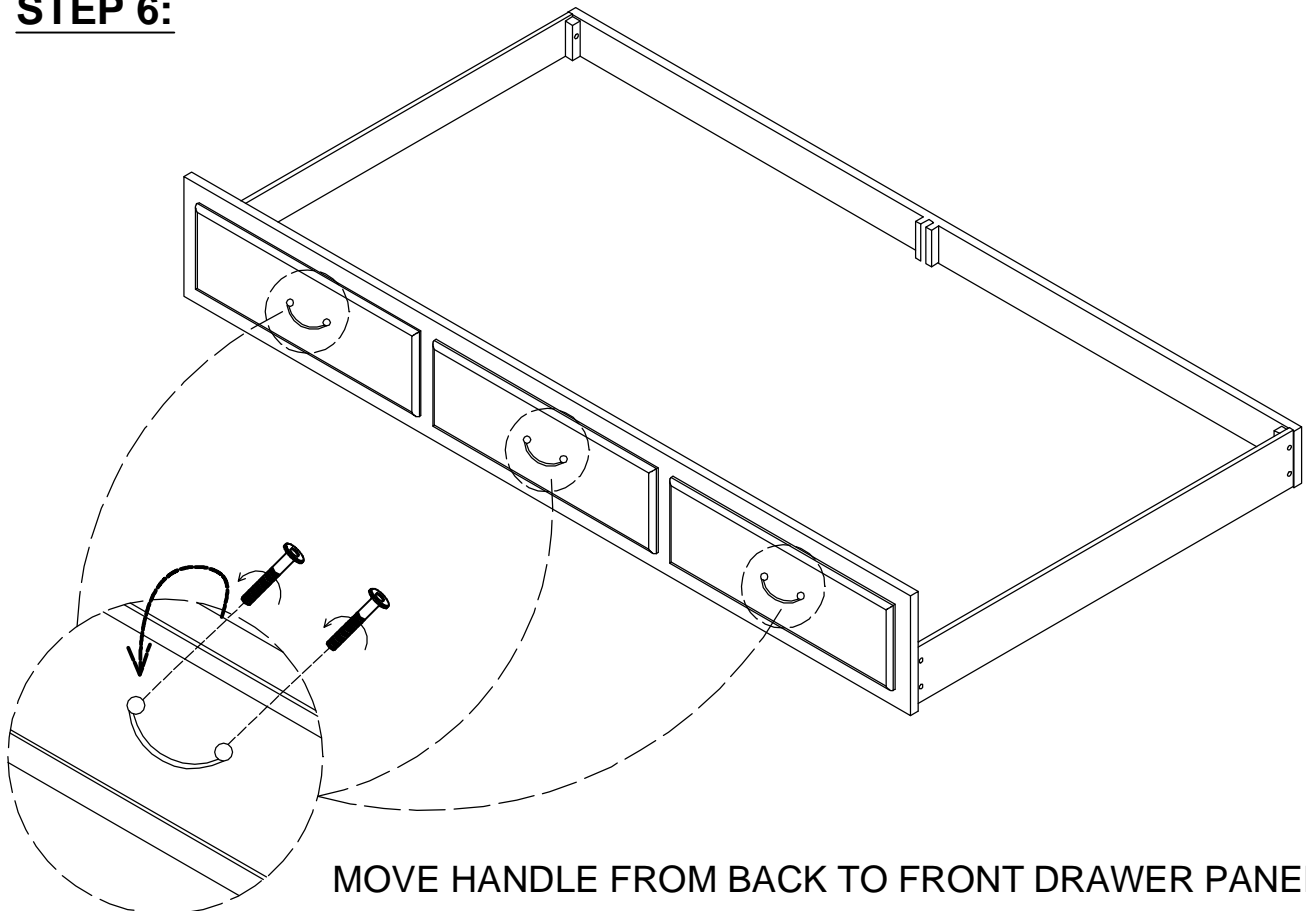

MOVE HANDLE FROM BACK TO FRONT DRAWER PANEL

3 PLACES

STEP 7:

**IF ADD THIS PARTITION, THEN YOU
CAN USING TWO DRAWERS**

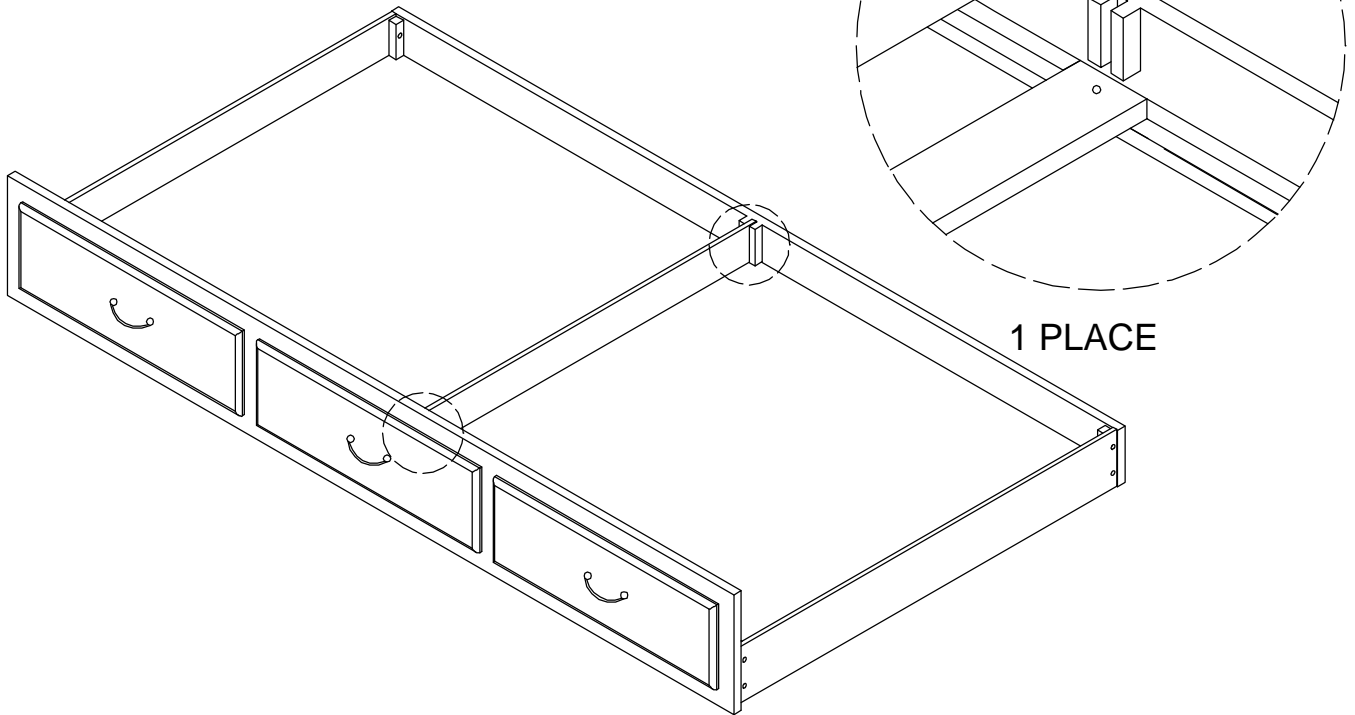

STEP 8:

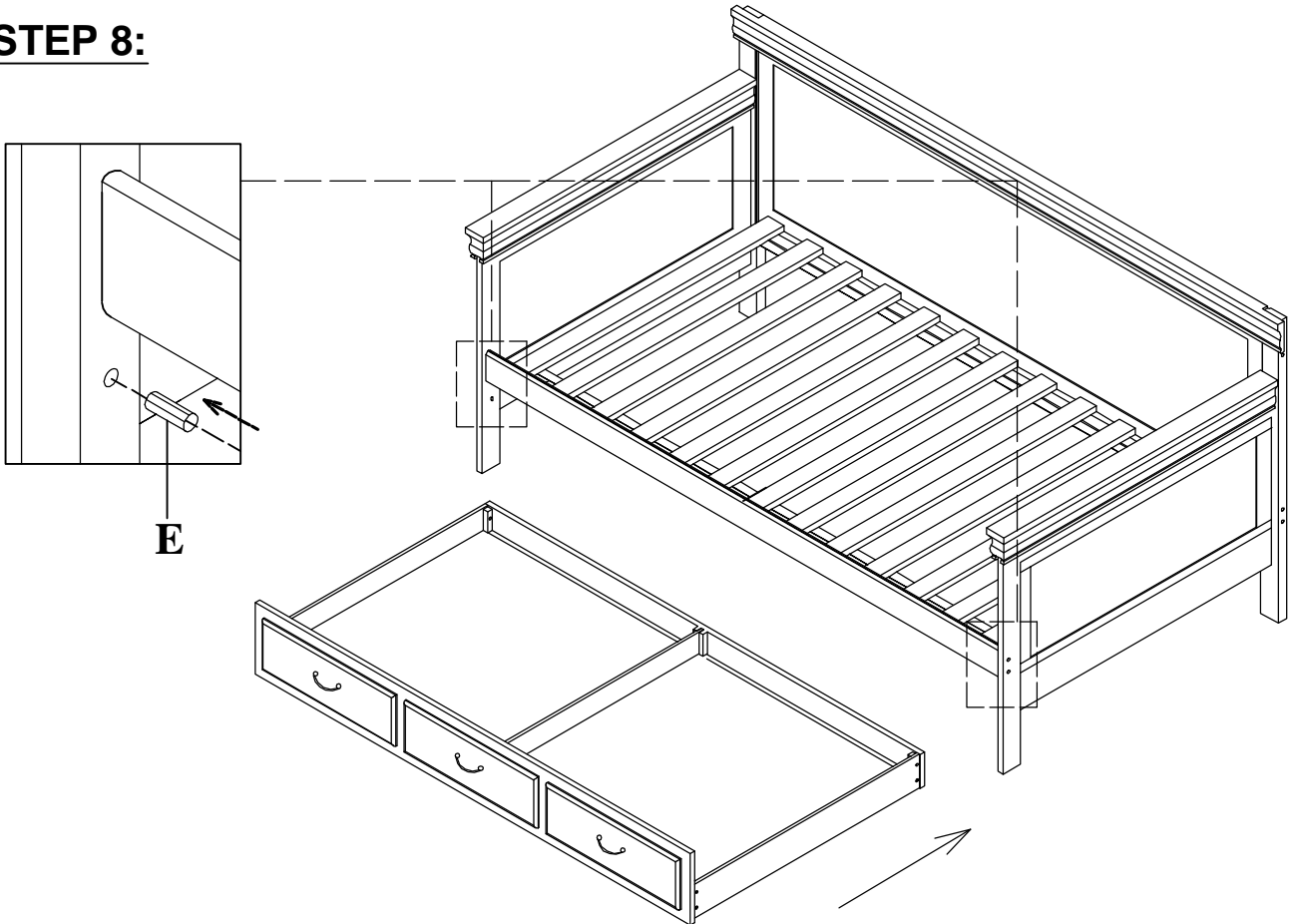

ASSEMBLY IS NOW COMPLETED