

ACMIE

FURNITURE

ASSEMBLY INSTRUCTIONS

Item No: #37173





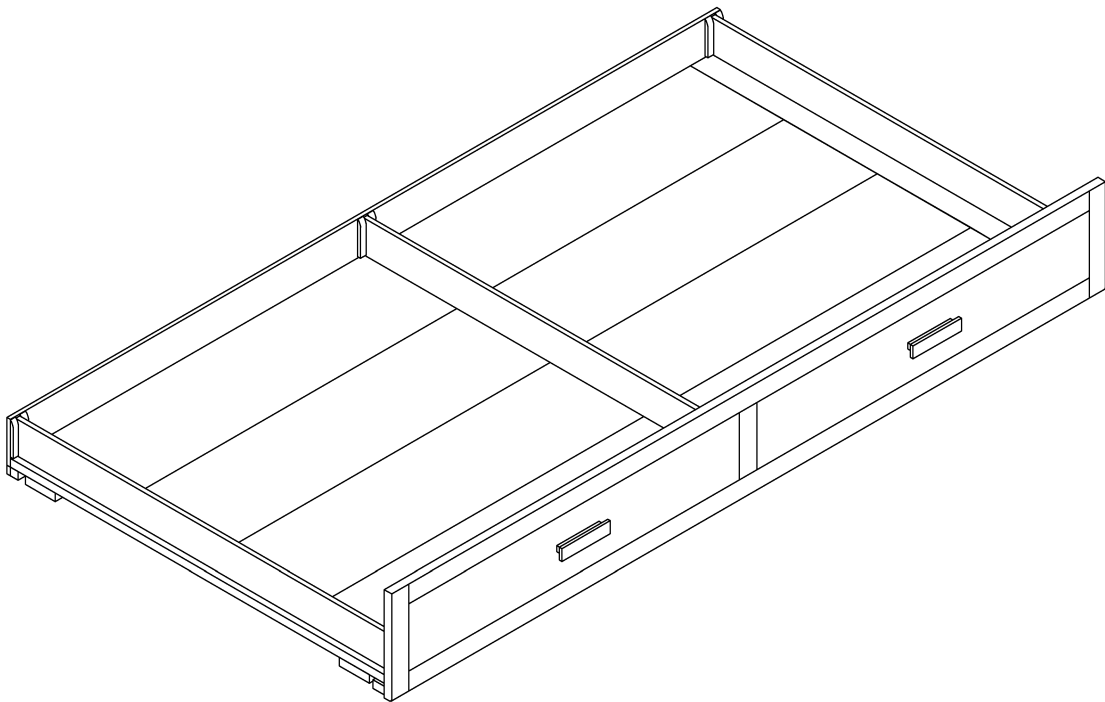

*** Thank you for purchasing this quality product. Be sure to check all packing materials carefully for small parts which may have come loose inside the carton during shipment. Identify and count all parts and compare with parts list below.

*** Assemble product on a flat, soft surface such as a carpet or cloth to prevent scratching the finish. Read all instruction and study the drawings carefully before starting the assembly process.













IMPORTANT: Do not tighten bolts completely until all bolts are completely lined up and inserted into holes

PARTS LIST

No	DIAGRAM	PART NAME	Q'Ty
1		Front trundle bed	1 pc
2		Back trundle bed	1 pc
3		Side trundle bed	2 pcs
4		Complete bottom panel (4pcs/1set)	1 set
5		Partition	3 pcs
6		Slat	3 pcs

HARDWARE LIST

No	DIAGRAM	PART NAME	Q'Ty
A		Bolt: 6.3 * 35 (mm)	8 pcs
B		Screw: 4 * 30 (mm)	6 pcs
C		Screw: 4 * 20 (mm)	8 pcs
D		Screw: 4 * 15 (mm)	8 pcs
E		"L" shape connection bracket	2 pcs
F		Wheel	4 pcs
G		Handle	2 pcs
H		Bolt	4 pcs
I		Flat Washer	4 pcs
J		Wood Dowel 10 x 40 (mm)	2 pcs
K		Allen Key (M4)	1 pc

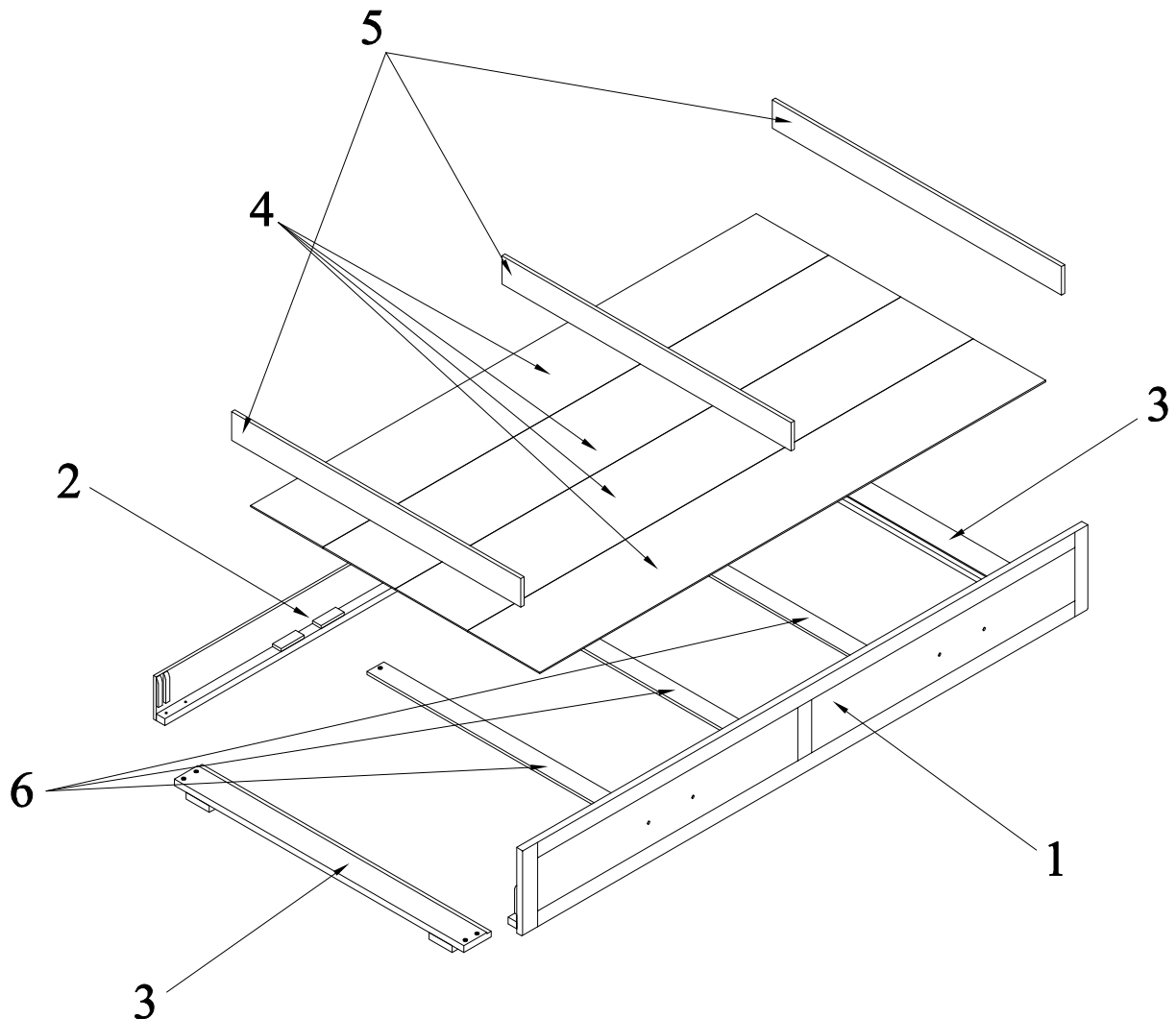

STEP 1: WHEEL ASSEMBLY

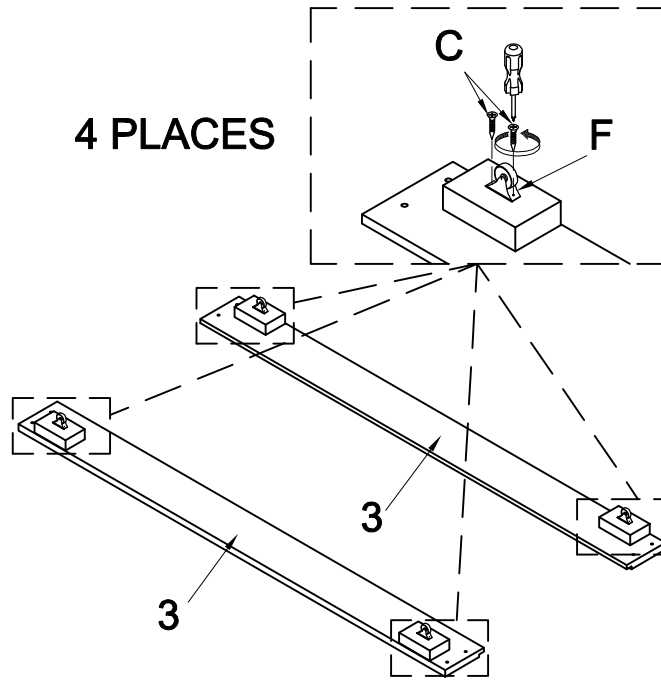

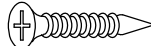
C  8 pcs

F  4 pcs

STEP 2: FRONT, BACK & SIDE TRUNDLE BED ASSEMBLY

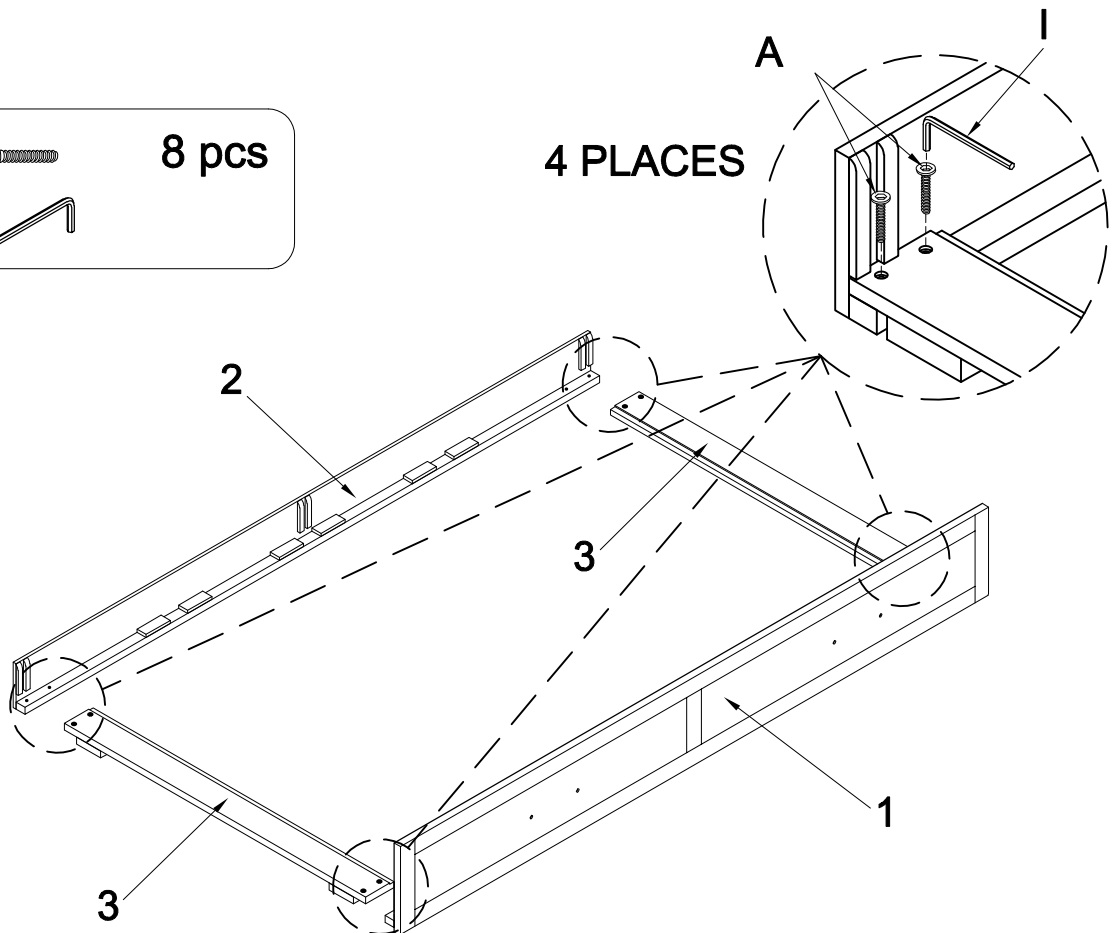
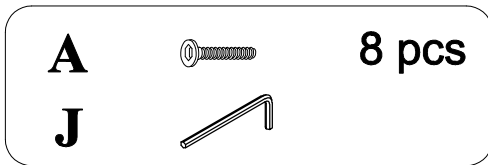

STEP 3: SLAT ASSEMBLY

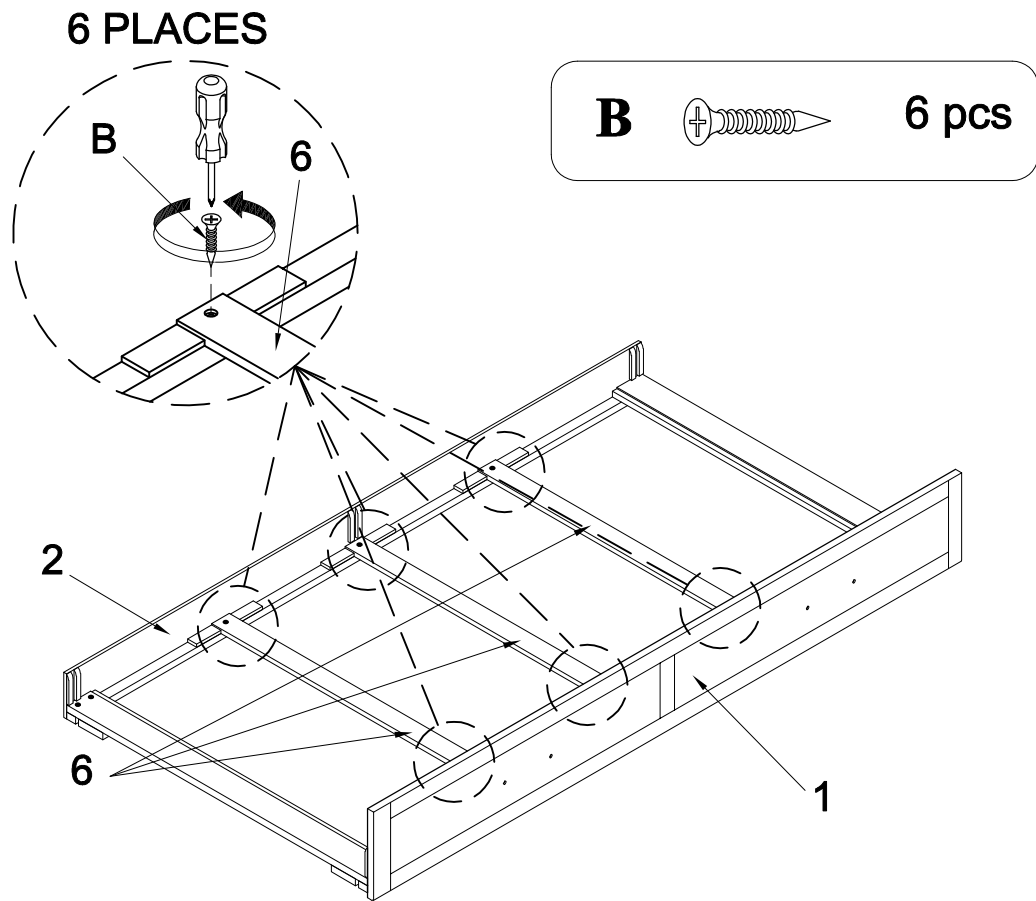

STEP 4: COMPLETE BOTTOM PANEL ASSEMBLY

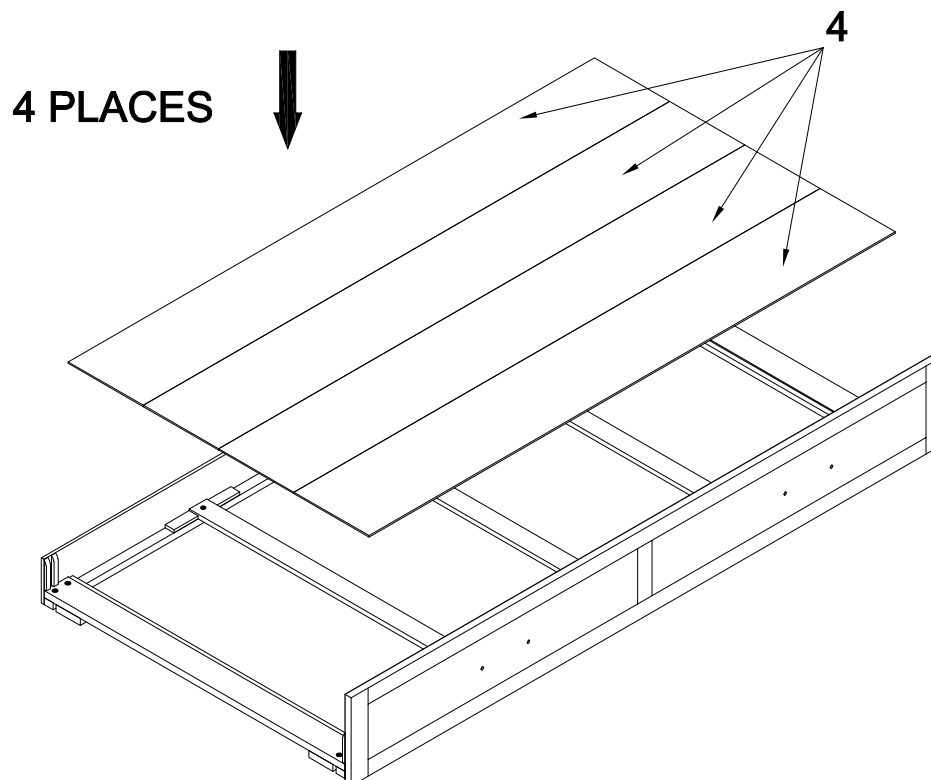

STEP 5: "L" SHAPE CONNECTION BRACKET ASSEMBLY

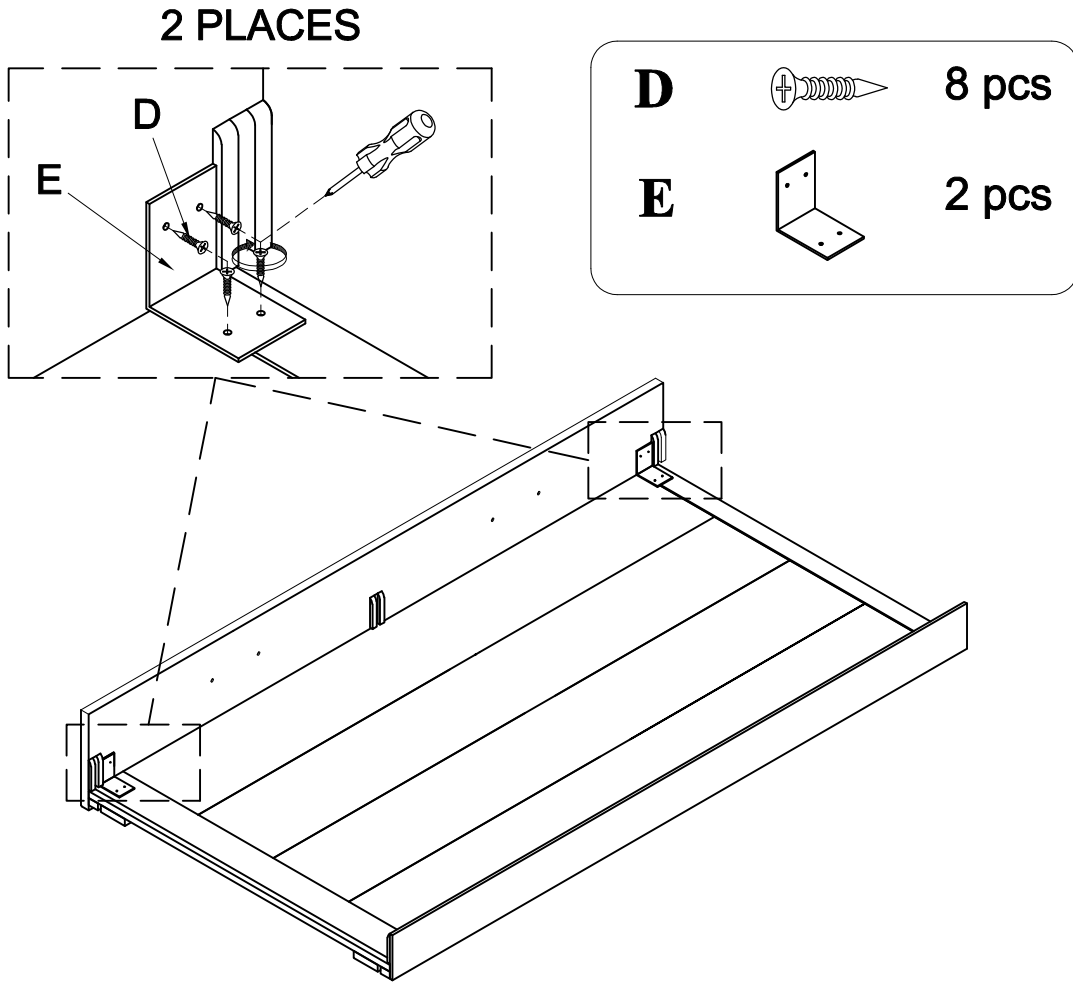

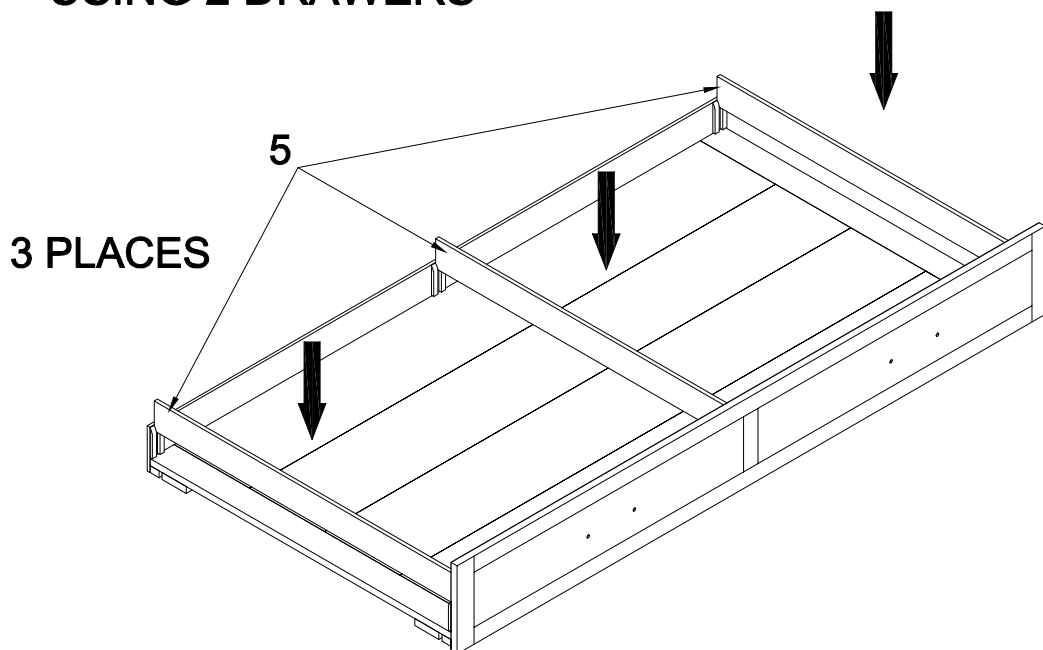

STEP 6:

IF ADD PARTITION (3PCS), AND THEN CAN BE USING 2 DRAWERS



STEP 7: ASSEMBLY HANDLE FRONT TRUNDLE BED

G		2 pcs
H		4 pcs
I		4 pcs

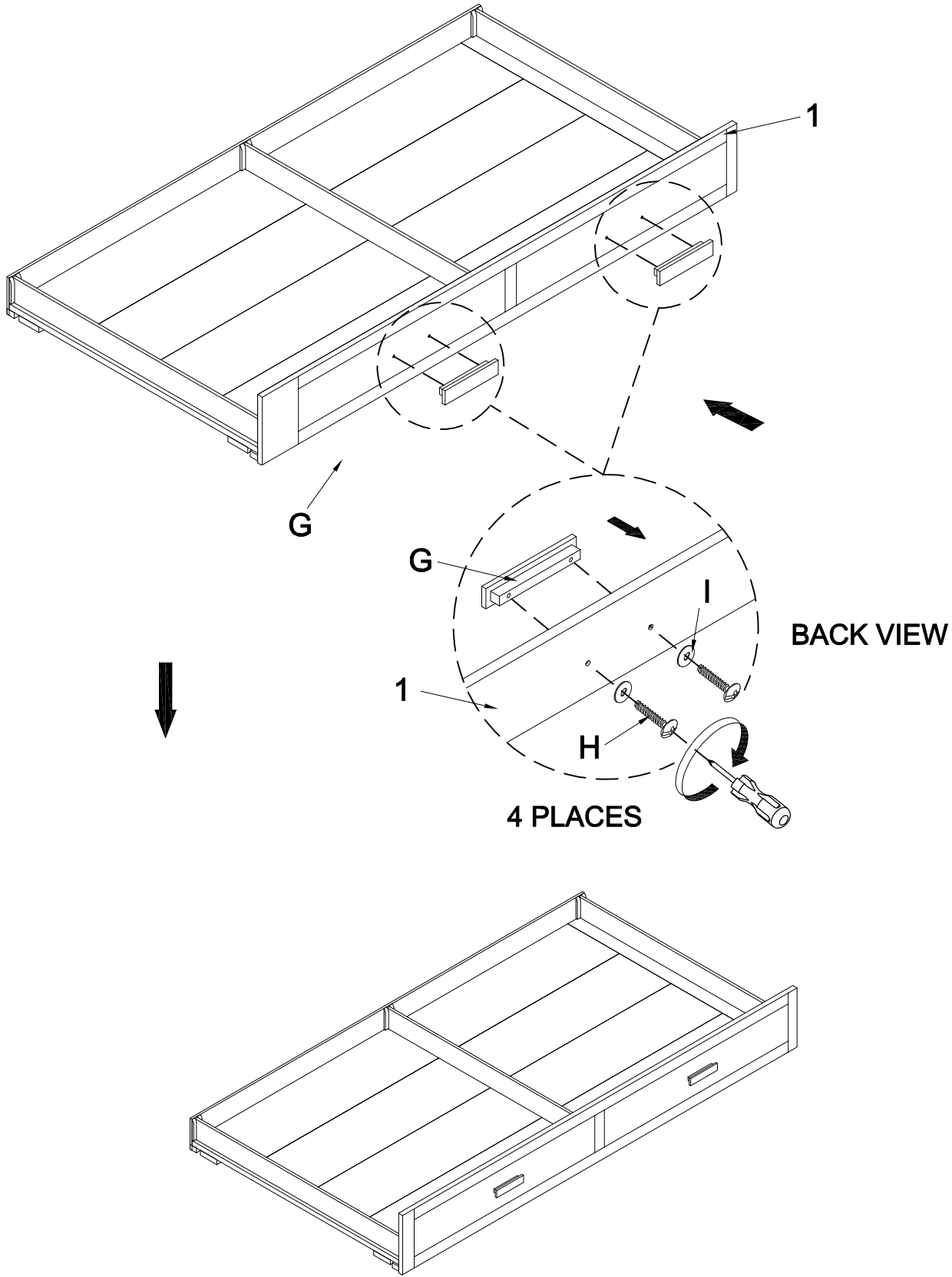

STEP 8: ASSEMBLY WOOD DOWEL

J  **2 pcs**

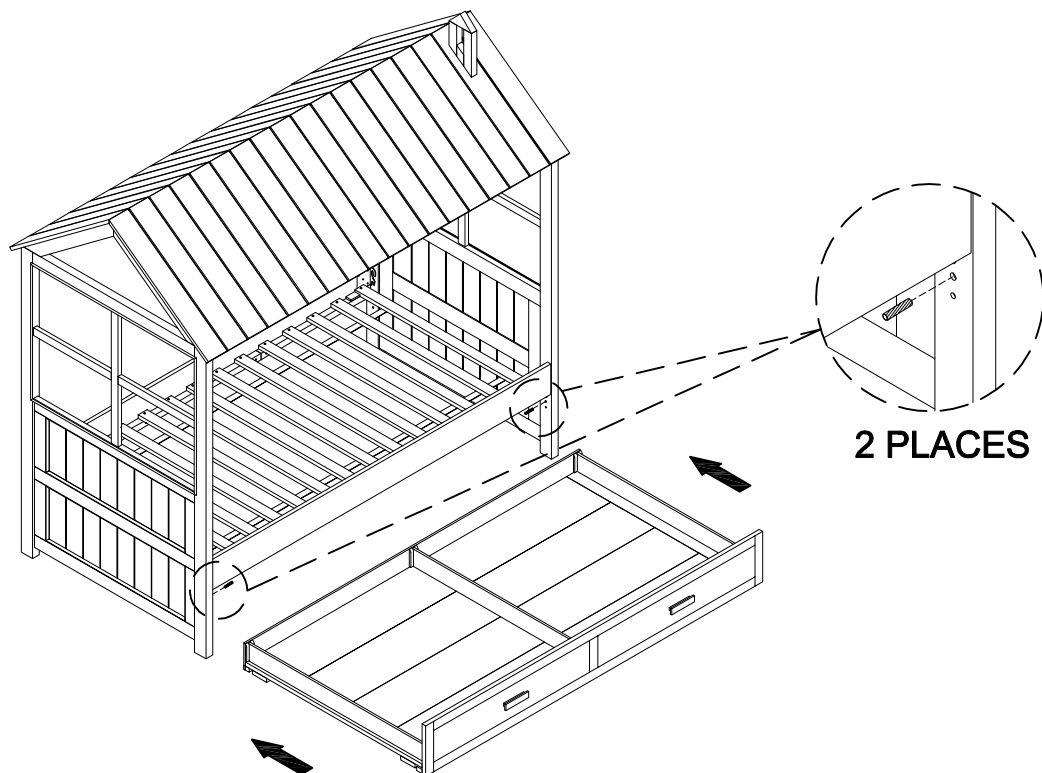

STEP 9:

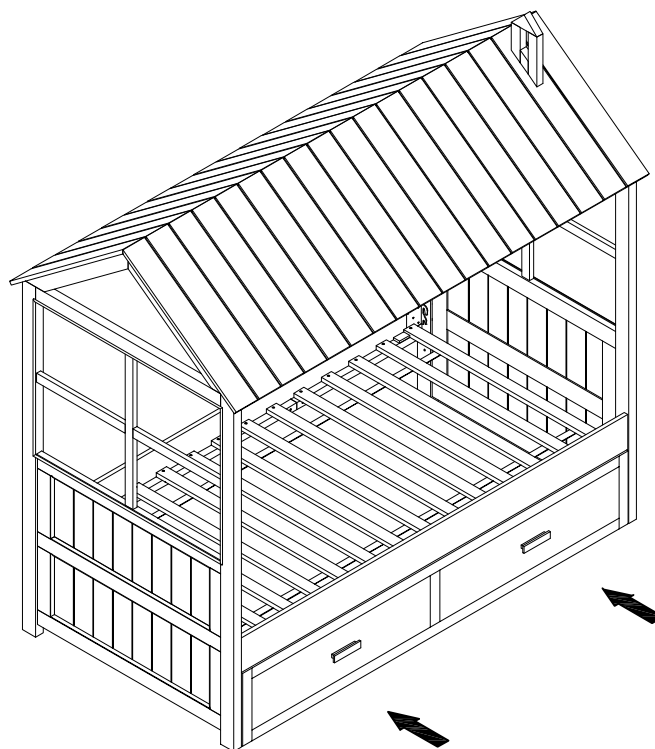

ASSEMBLY IS COMPLETED