

# **ASSEMBLY INSTRUCTIONS**

ITEM NO.:22040Q

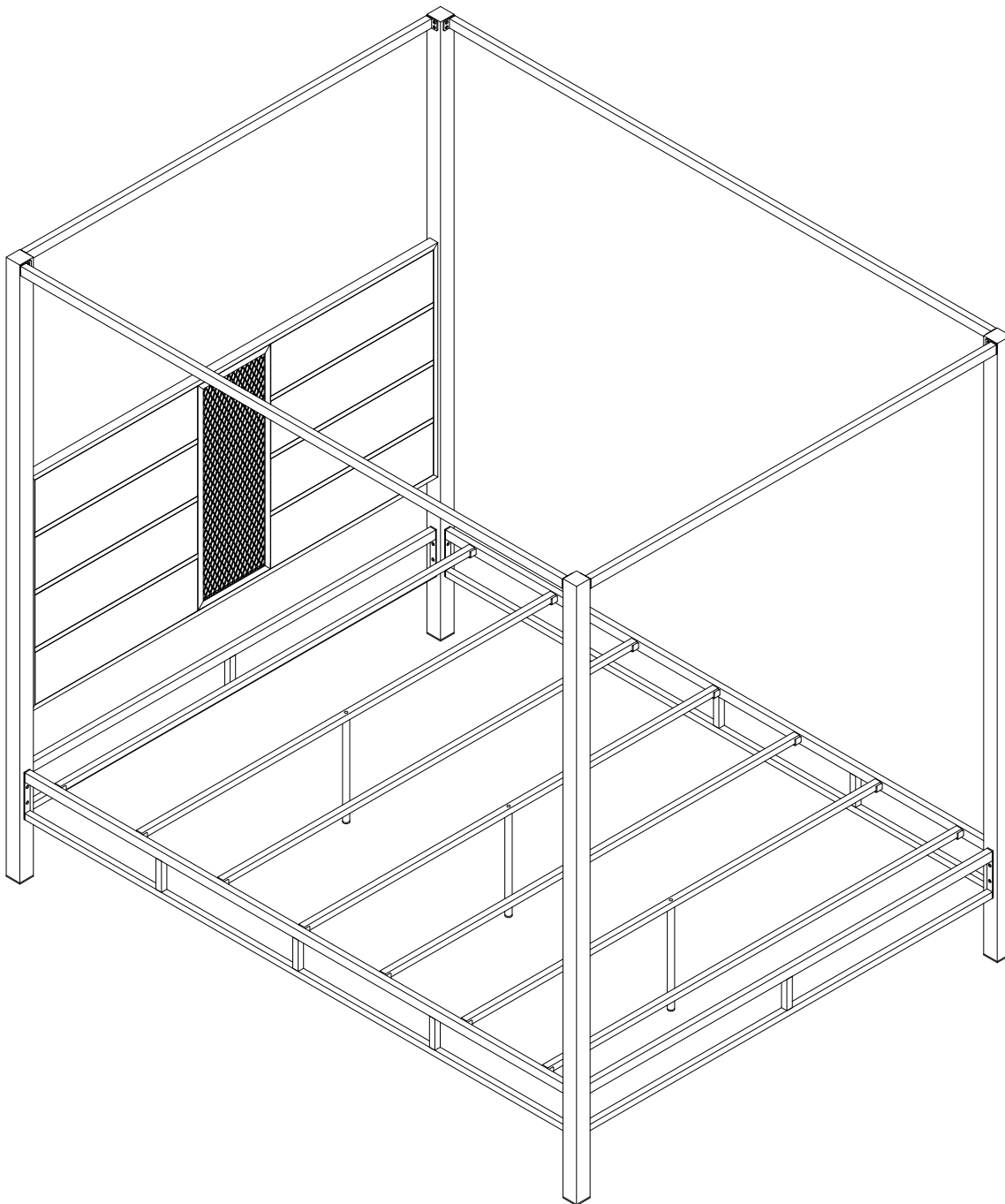

**Do not tighten screws until completely assembled.**

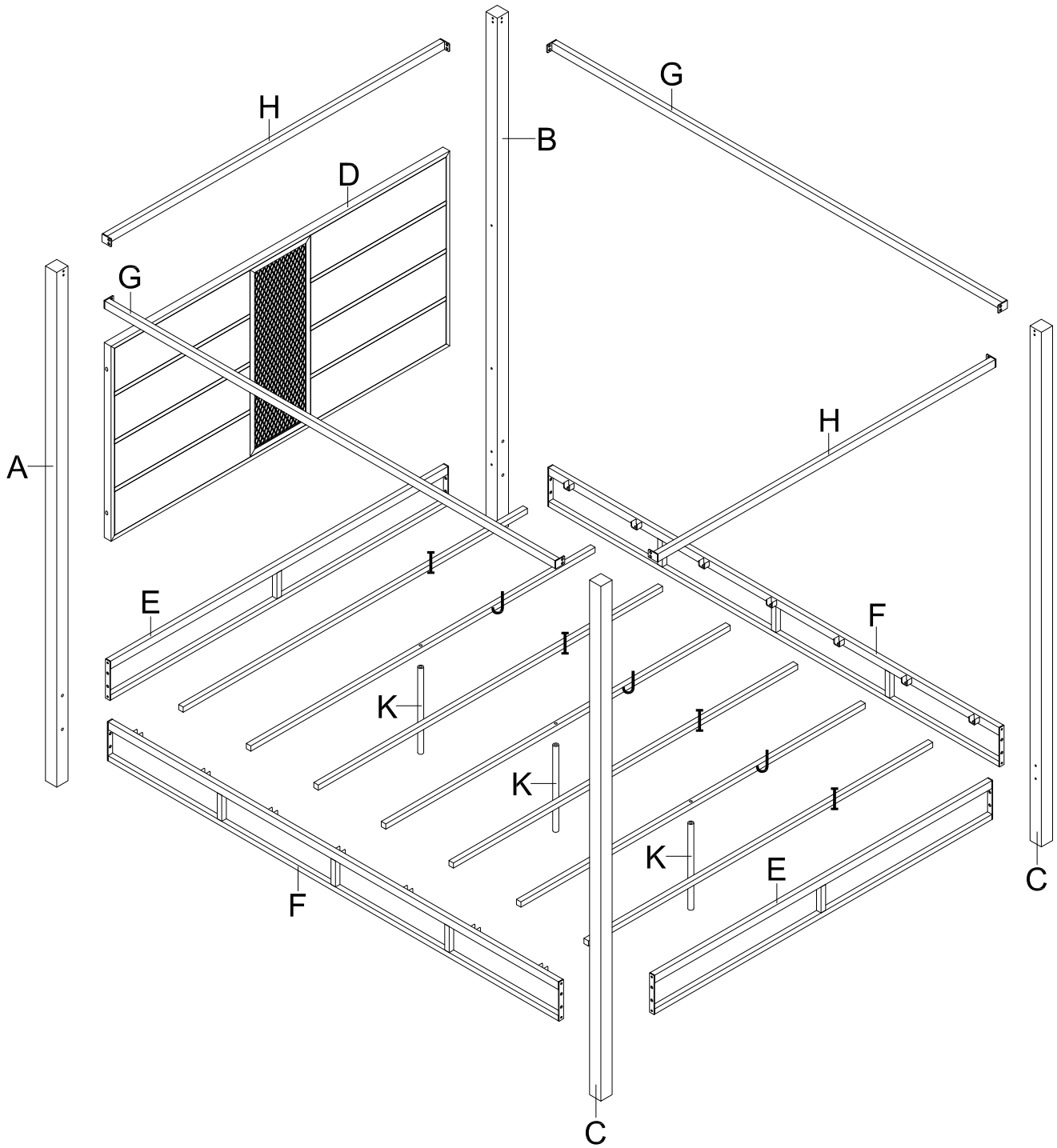

# PARTS IDENTIFICATION

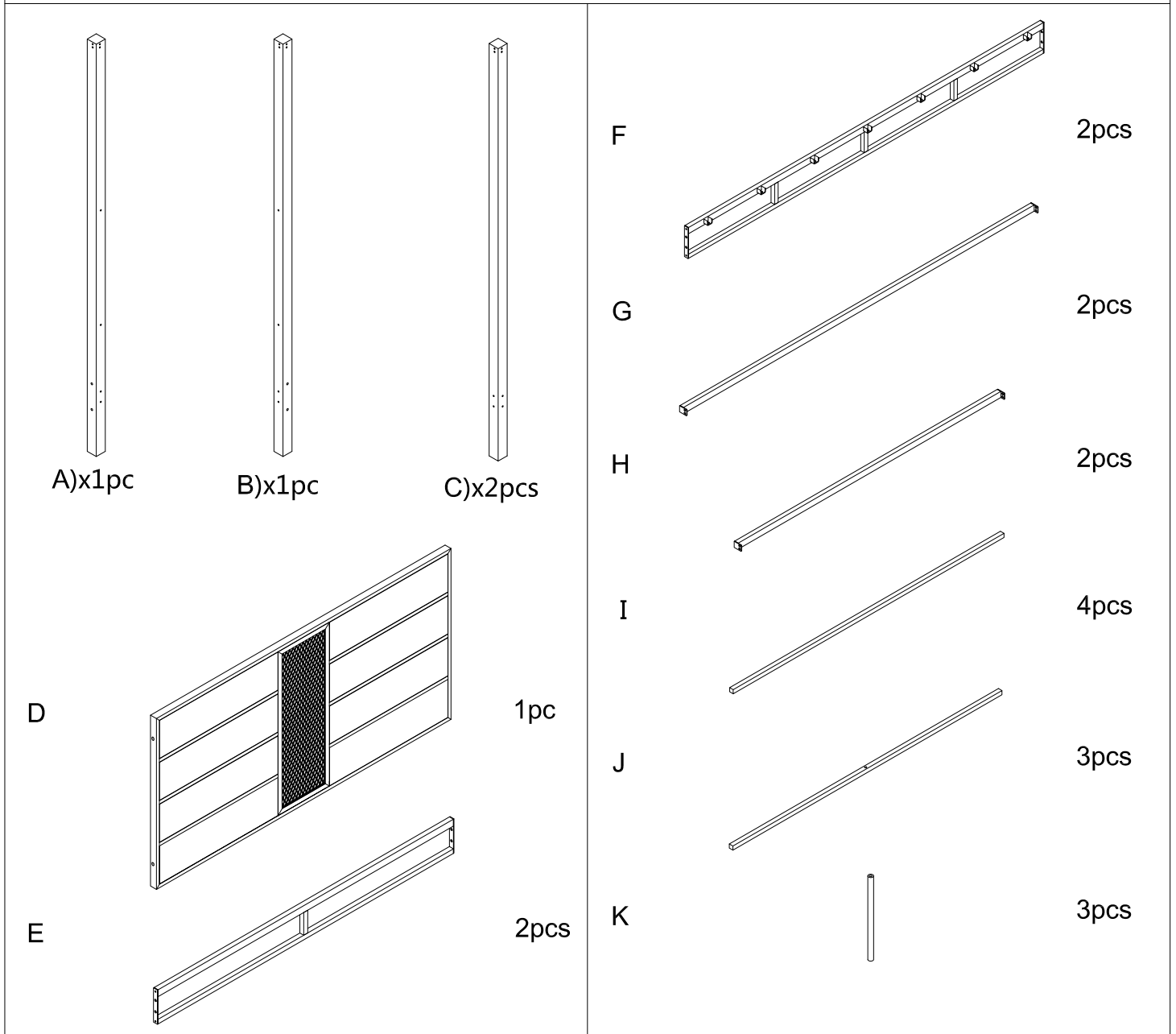

# PARTS IDENTIFICATION

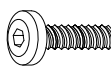
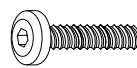
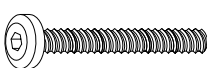

## HARDWARE LIST

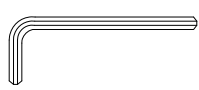
<b>1</b>  M6x15                      34pcs	<b>2</b>  M6x25                      4pcs	<b>3</b>  M6x35                      3pcs
<b>4</b>  M6x65                      4pcs	<b>5</b>  Ø16xØ7x1.0              6pcs	<b>6</b>  Ø18xØ9x2.0              4pcs
<b>7</b>  4x4                              1pc		

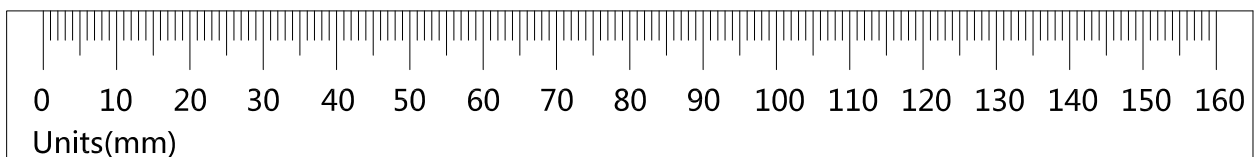

# STEP 1.

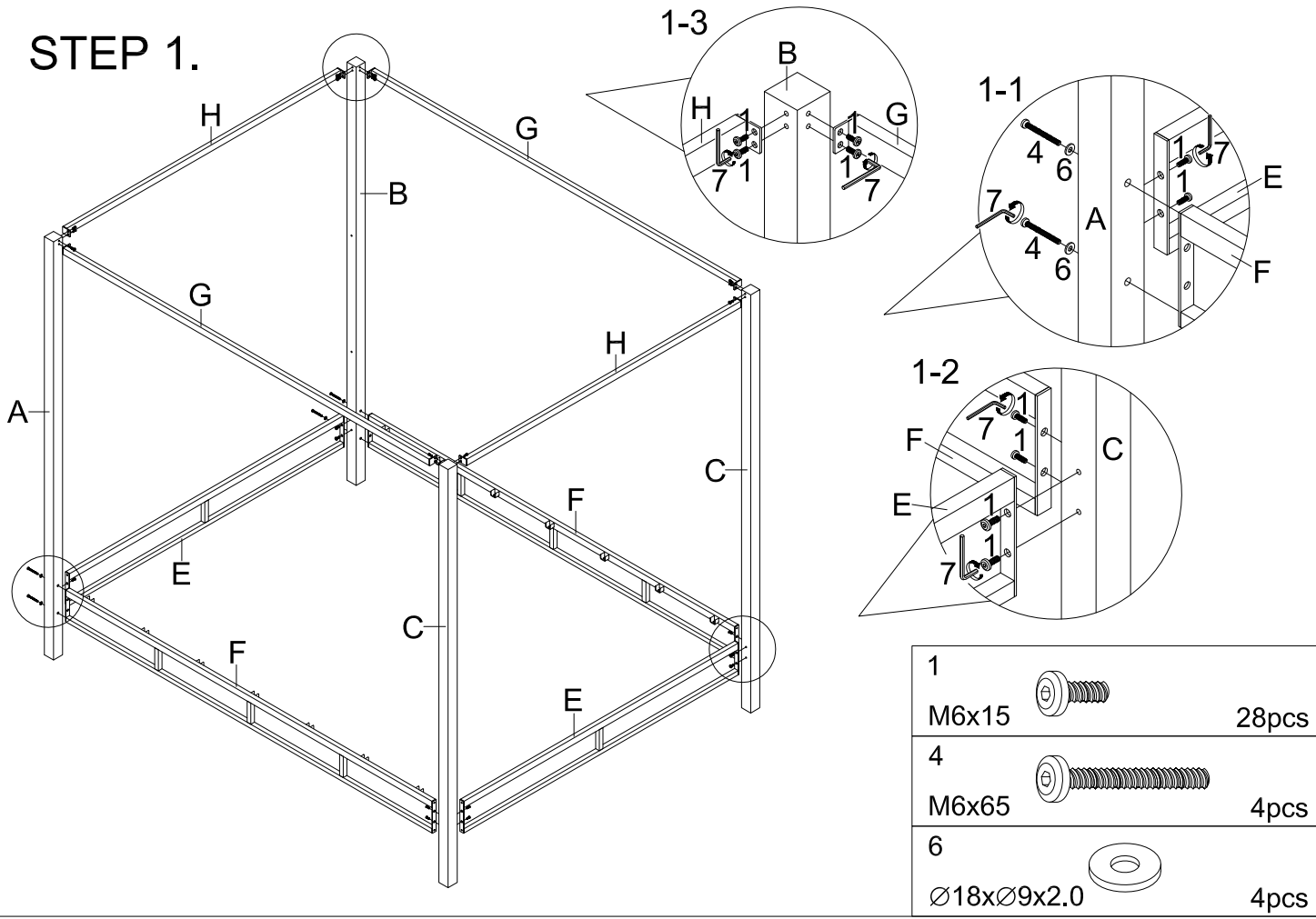

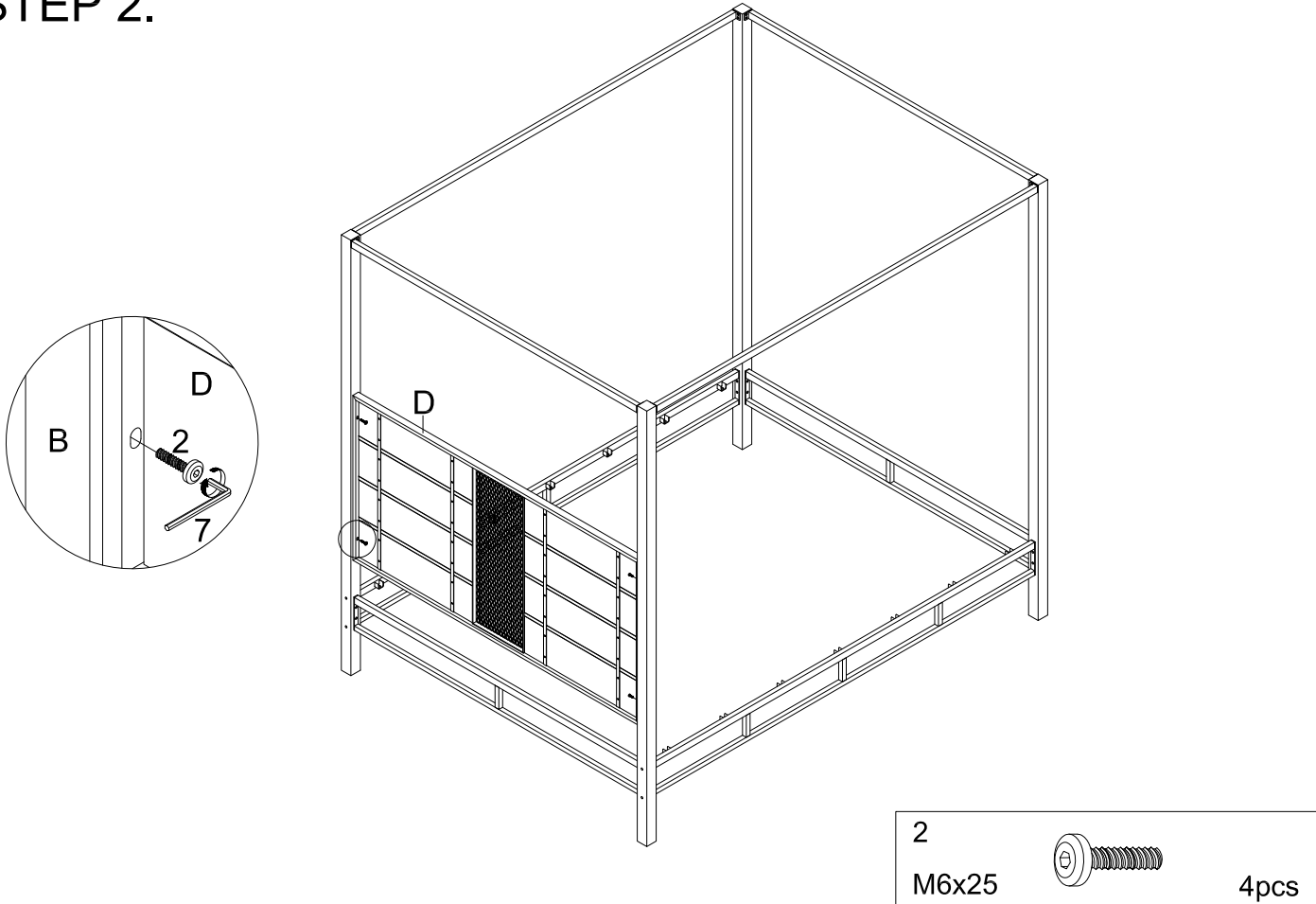

# STEP 2.



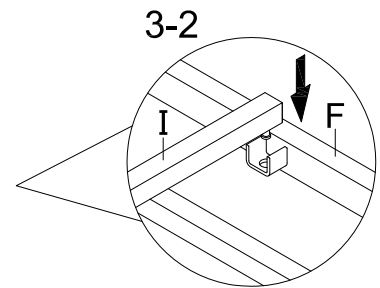
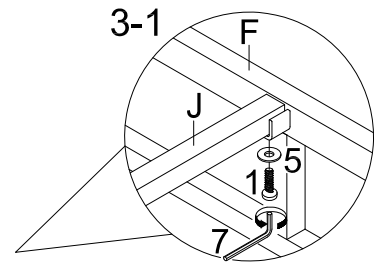
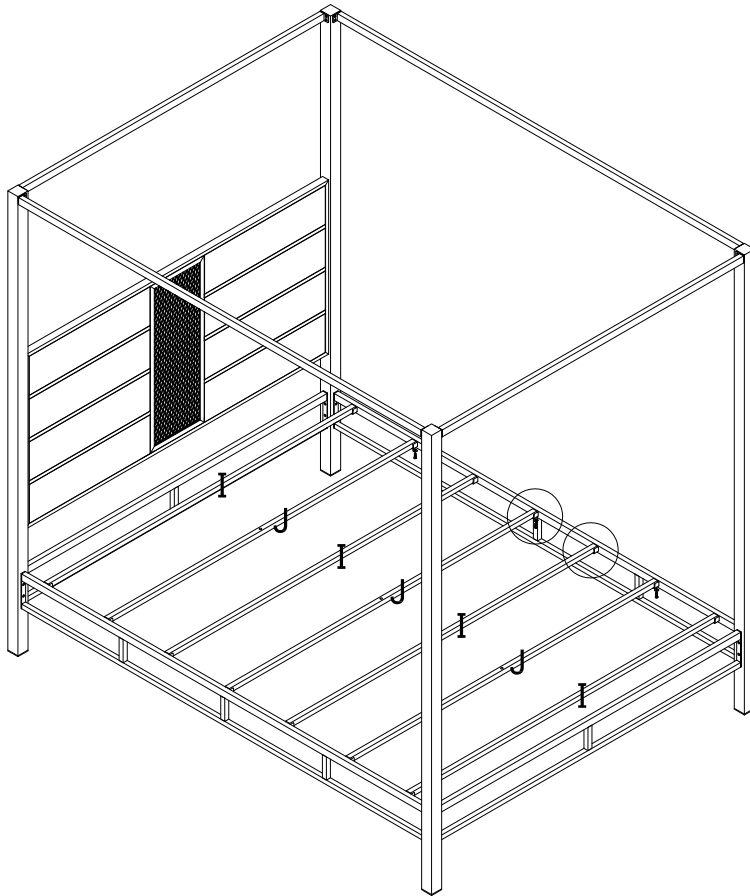

### STEP 3.

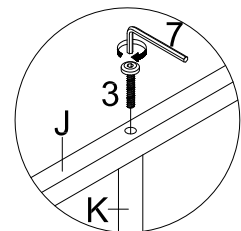
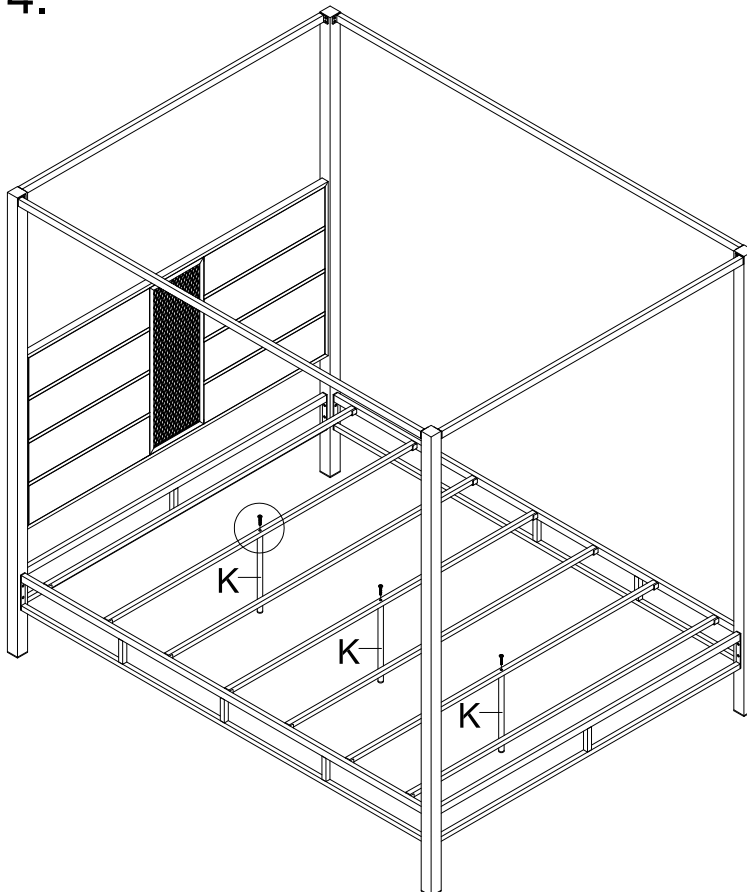

1		6pcs
M6x15		
5		6pcs
Ø16xØ7x1.0		

### STEP 4.



3		3pcs
M6x35		