

# ASSEMBLY INSTRUCTIONS

**MODEL : FBKHFK-108A+FBQHFL-108A  
+FBKSRR-108A  
+FBKDW-108A**

**REVISION : A**

**ASSEMBLY TIPS :**

1. Remove hardware from box and sort by size.
2. Please check to see that all hardware and parts are present prior to start of assembly.
3. Please follow attached instructions in the same sequence as numbered to assure fast and easy assembly.

**Component List**

**Headboard & Footboard**

No	Descriptions	Qty
A	Headboard Panel	1
B	Footboard Panel	1
C	Headboard Back Cover	1
D	Footboard Back Cover	1
E	Slat Cover	1

**Side Rail**

No	Descriptions	Qty
F	Bed Rail	2
G	Drawer Slat	1
H	Drawer Slat Support	1
I	Drawer Slat Support Stopper	1
J	Bed Slat 3 Holes	3
K	Bed Slat 2 Holes	10
L	Bed Slat Support	3
M	Center Slat	1

**Leg**

No	Descriptions	Qty
N	Headboard Leg Left and Right	2
P	Footboard Leg Left and Right	2

**Drawer**

No	Descriptions	Qty
Q	Drawer	2

**Hardware List In Headboard & Footboard**

No	Descriptions	Qty
1	JCBC Screw M6 x 35mm	12
2	Spring Washer Ø1/4"	12
3	Flat Washer Ø1/4" x 20mm	28
4	L Key M4 x 100mm	1
5	L Key M5	1
6	Wood Dowel 10mm x 30mm	8
7	JCBC Screw M6 x 16mm	16
8	CSK M4 x 16mm	6

**Hardware List In Side Rail**

No	Descriptions	Qty
9	JCBC Screw M6 x 50mm	3
10	CSK M4 x 32mm	30
11	L Key M4 x 65mm	1

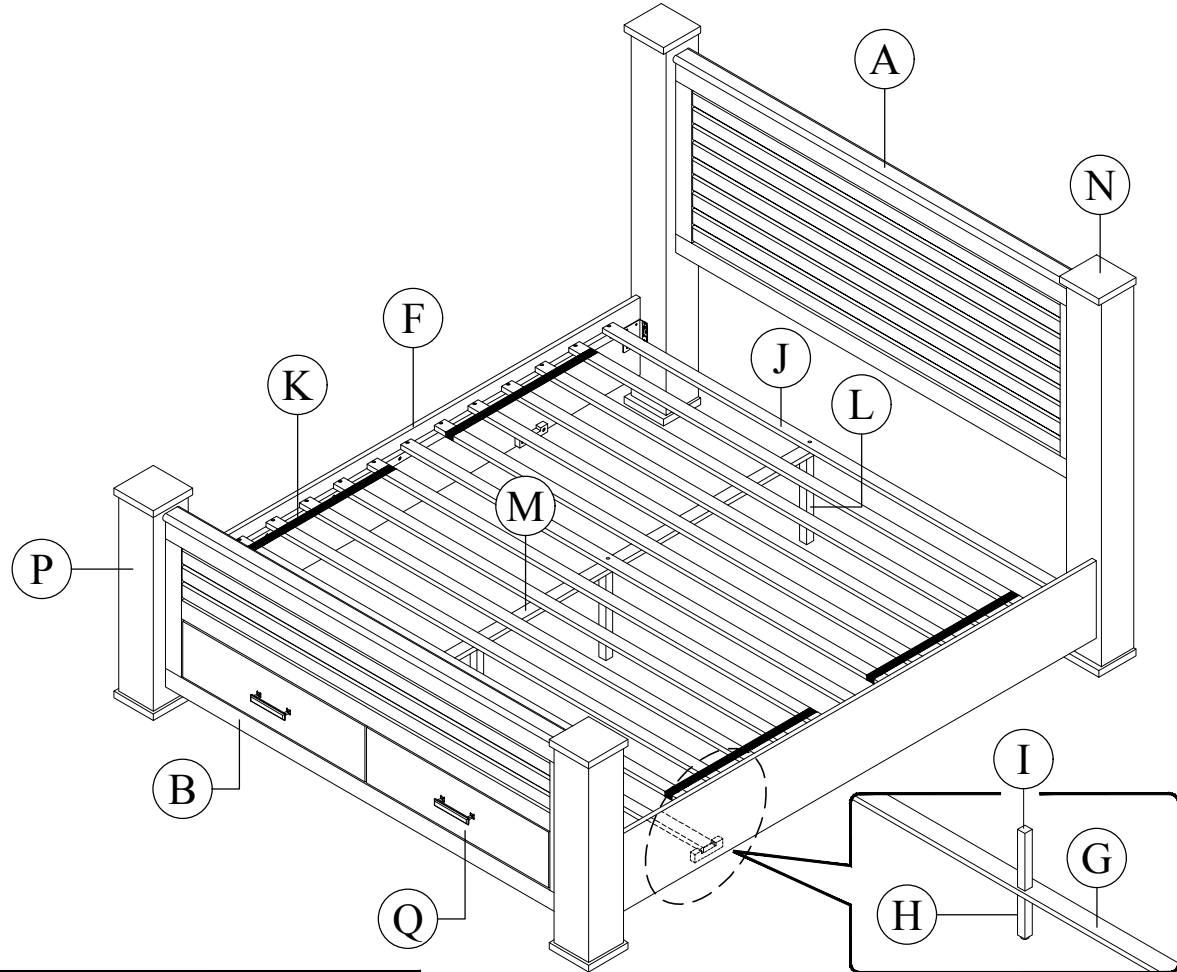

# ASSEMBLY INSTRUCTIONS

- STEP 1.1: Insert wood dowel (6) to the pre-drilled hole of headboard panel (A) / footboard panel (B).
- STEP 1.2: Push the headboard leg (N) / footboard leg (P) to fit with the wood dowel (6) at the headboard panel (A) / footboard panel (B).
- STEP 1.3: Attach the headboard leg (N) / footboard leg (P) by using JCBC Screw M6 x 35mm (1), springwasher (2) and flat washer (3) through the pre-drilled hole of headboard leg (N) / footboard leg (P) and tighten by using Allen key (4).
- STEP 1.4: Repeat Step 1.1 to step 1.3 For the other side leg.
- STEP 1.5: Attach the headboard back cover (C) on the back side of headboard panel (A), and attach the footboard back cover (D) on the back side of footboard panel (B).

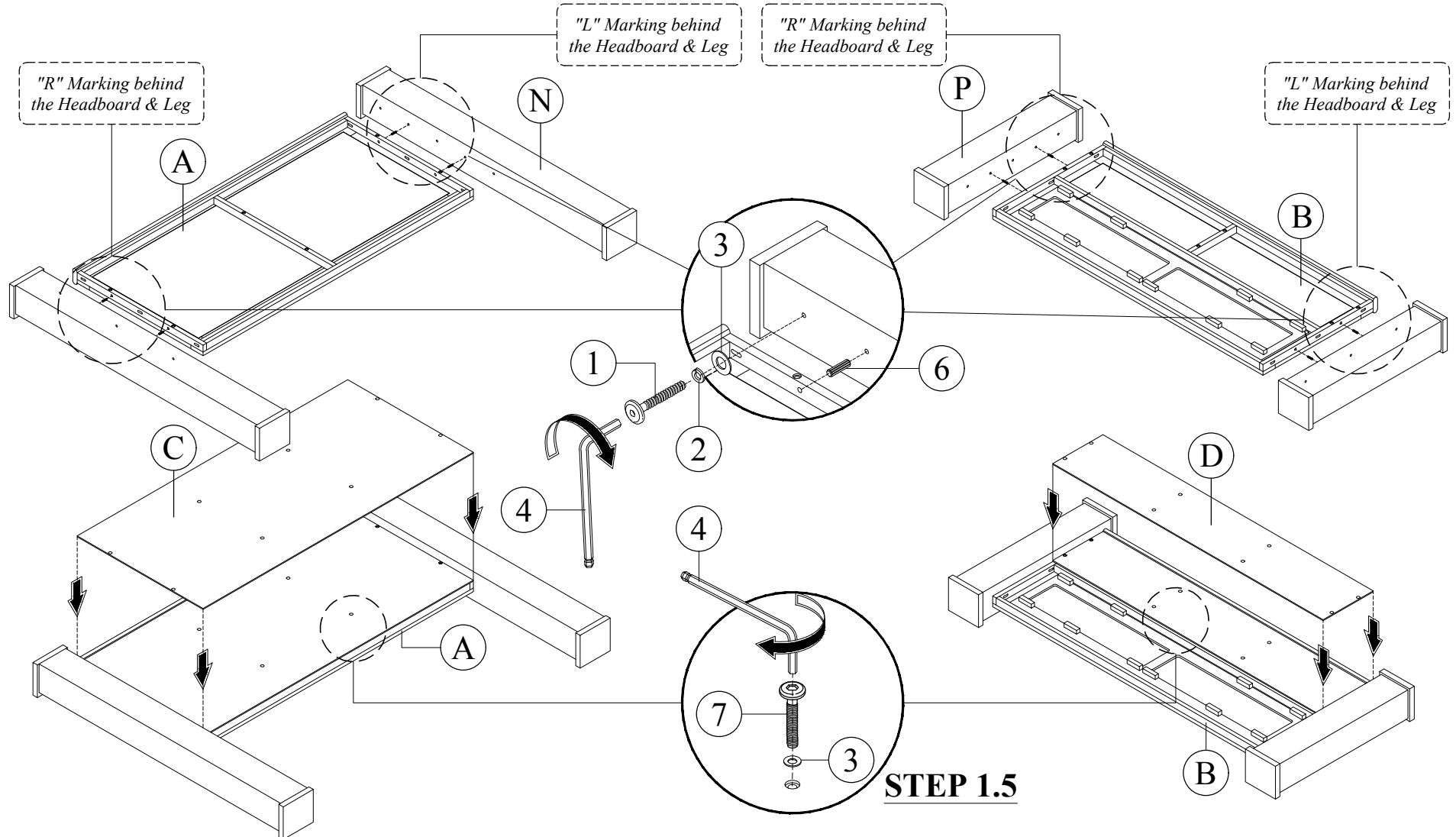

# ASSEMBLY INSTRUCTIONS

- STEP 2.1: Attach the bed rail (F) to headboard leg (N).  
STEP 2.2: Tighten screw on headboard leg (N) by using L key M5 (5) & repeat the same step on footboard leg (P).  
STEP 2.3: Attach the drawer slat (G) each to a drawer slat support (H) & fix with drawer slat support stopper (I).  
STEP 2.4: Fix the drawer slat (G) to bed rail (F) with CSK M4 x 32mm (10).  
STEP 2.5: Move 'T' runner at footboard panel (B) to drawer slat (G).

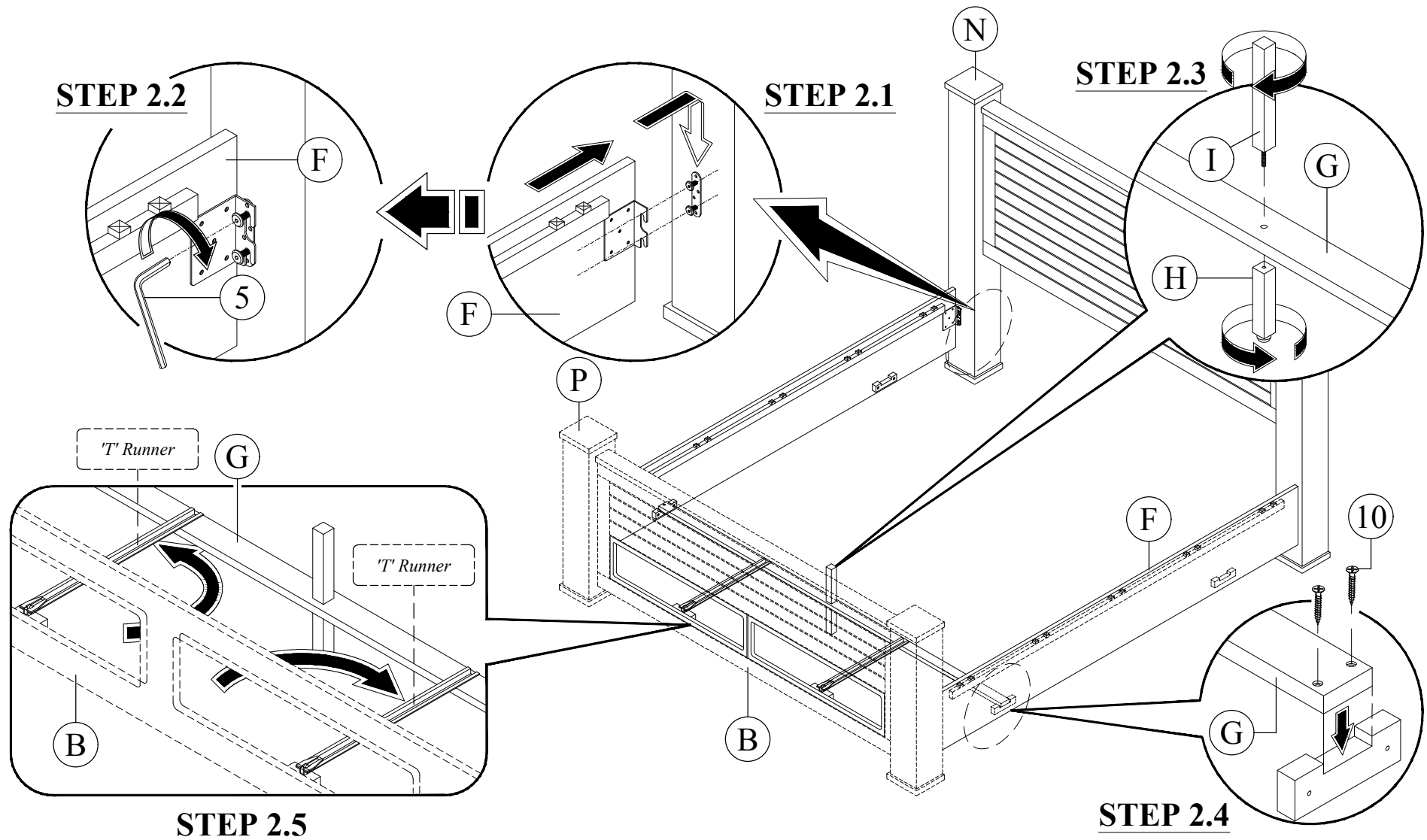

# ASSEMBLY INSTRUCTIONS

STEP 3.1: Insert drawer (Q) to footboard (B) until completely closed.

STEP 3.2: Tighten 'T' runner at footboard (B) to drawer slat (G) with CSK M4 x 16mm (8).

STEP 3.3: If drawer (Q) does not close properly, adjust the adjuster at the bottom of drawer slat support (H) up or down until the drawer (Q) closes tightly.

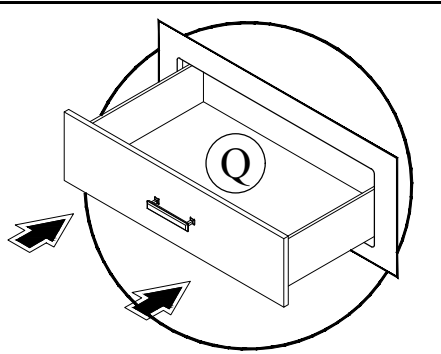

**STEP 3.1**

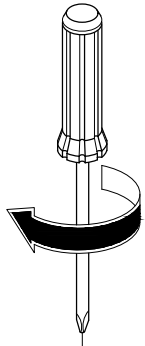

**STEP 3.2**

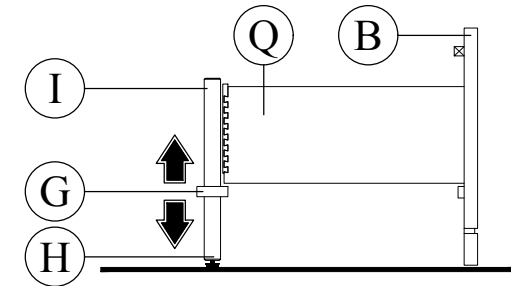
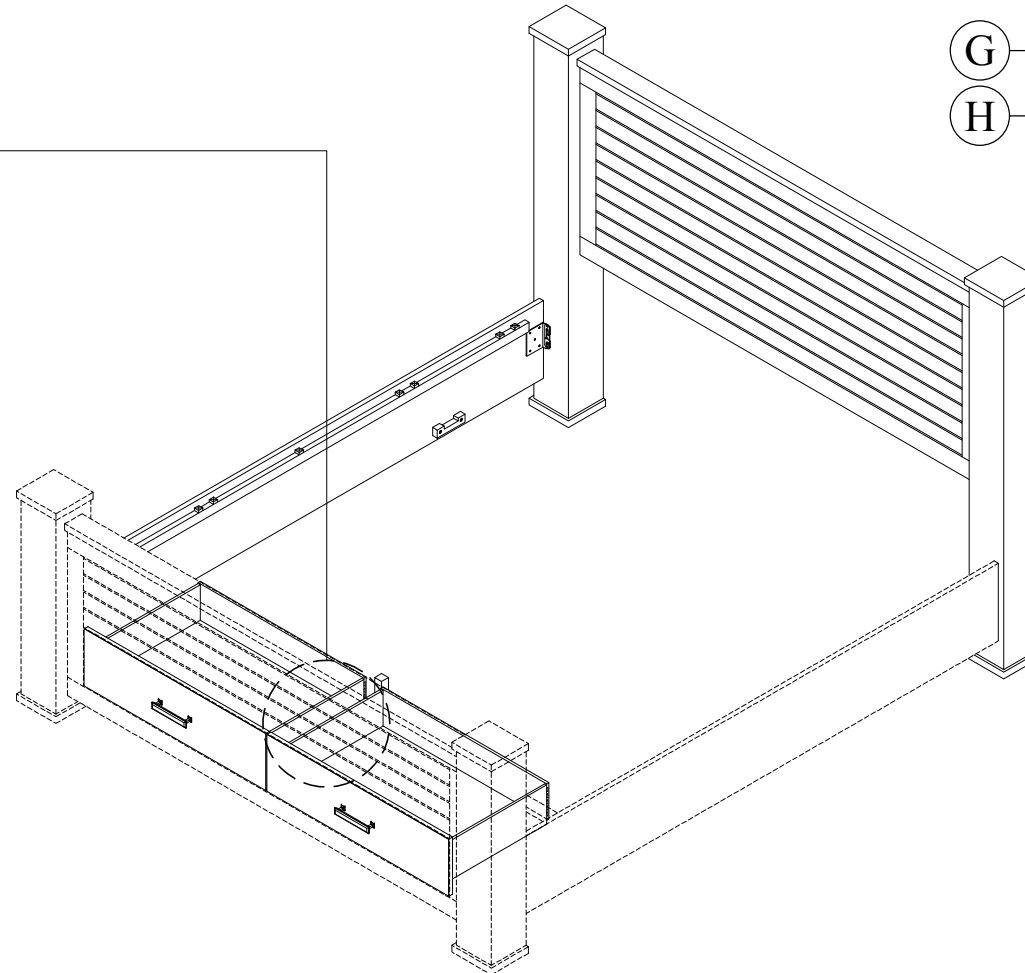
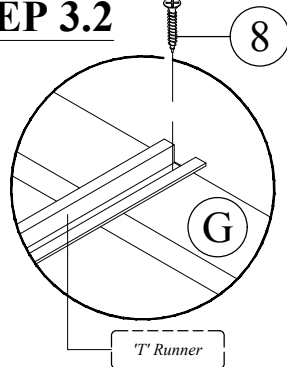

**STEP 3.3**

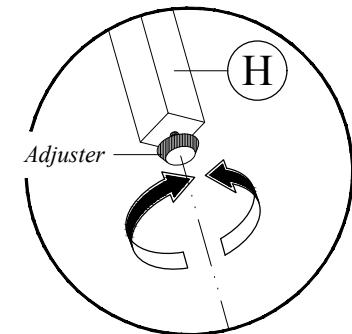

# ASSEMBLY INSTRUCTIONS

STEP 4.1: Attach the center slat (M), bed slat (J) to bed slat support (L). Tighten with JCBC M6 x 50mm (9) by using L key M4 (11).

STEP 4.2: Attach bed slat (J) & bed slat (K) and tighten to bed rail (F) with CSK M4 x 32mm (10).

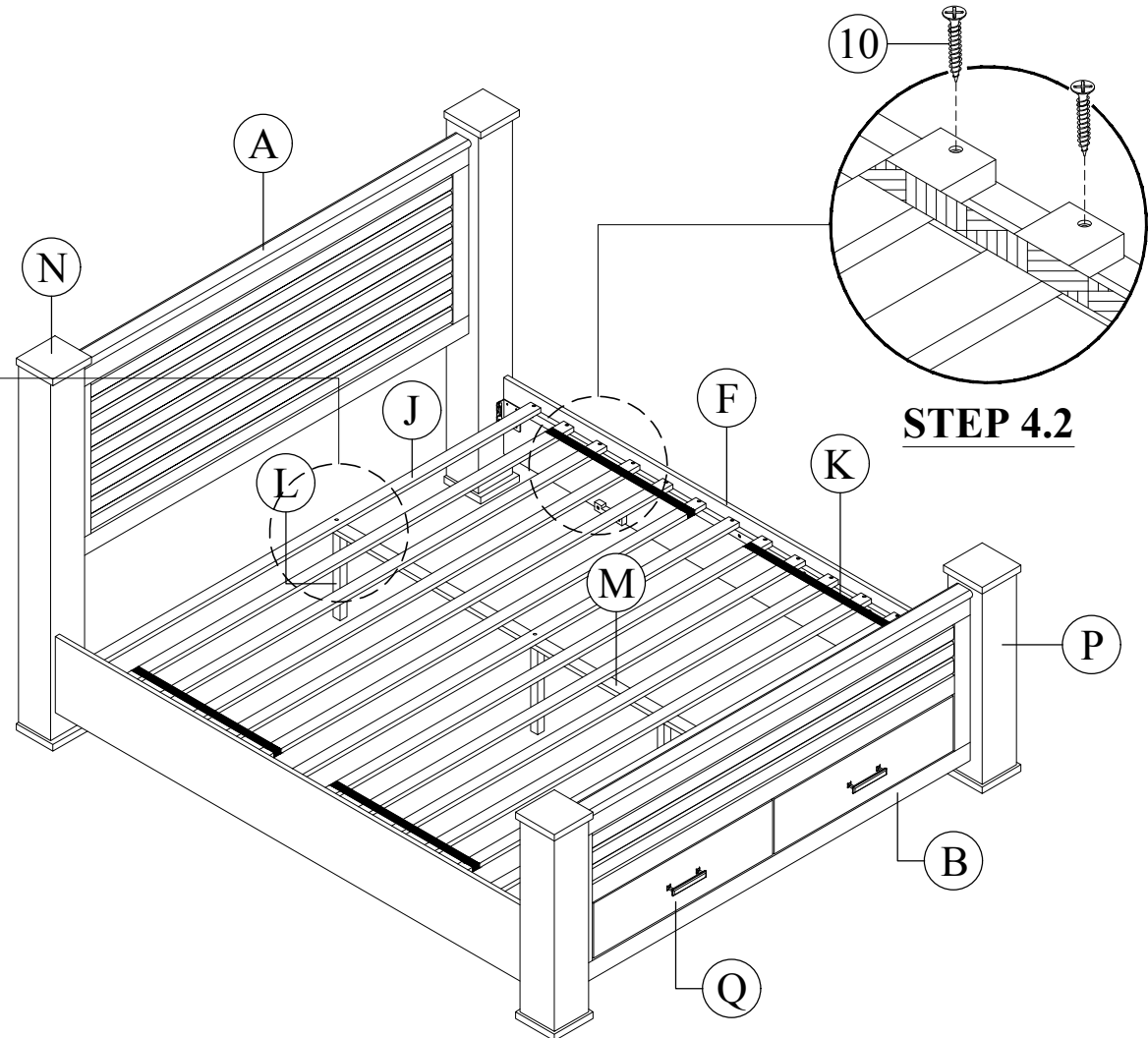
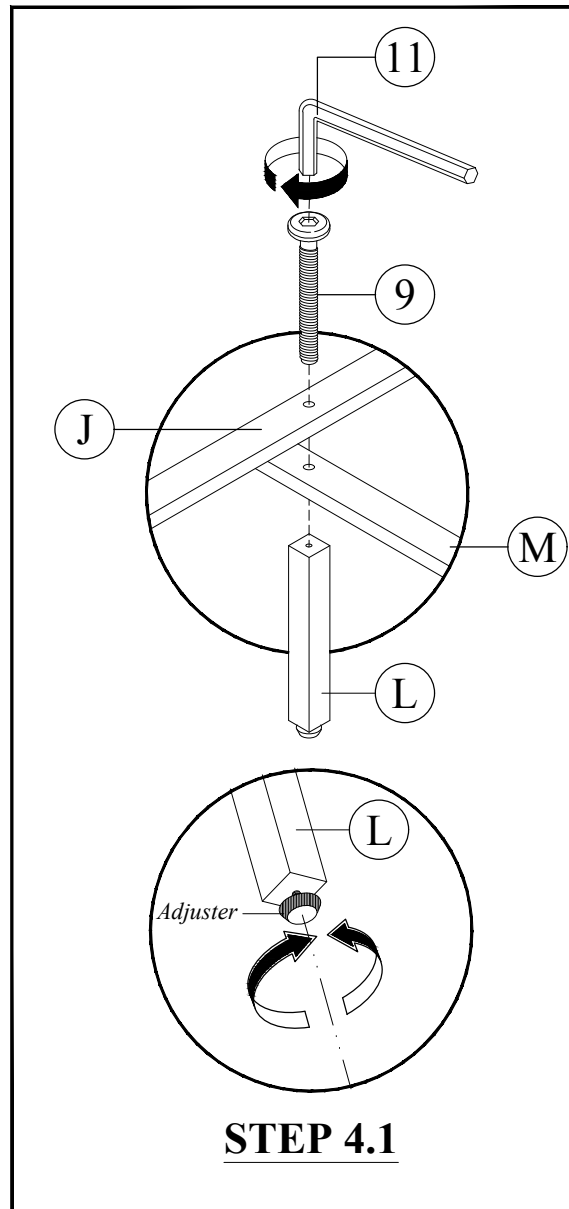

# ASSEMBLY INSTRUCTIONS

- STEP 5.1: Insert the tip of slat cover (E) on the back of the footboard (B) until closely.
- STEP 5.2: Use CSK M4 x 16mm (8) to fasten the slat cover (E) on the bed slat (K).

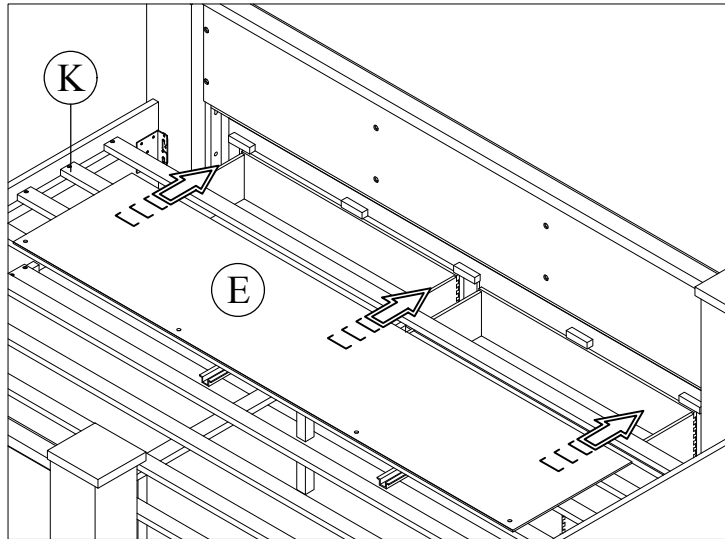

**STEP 5.1**

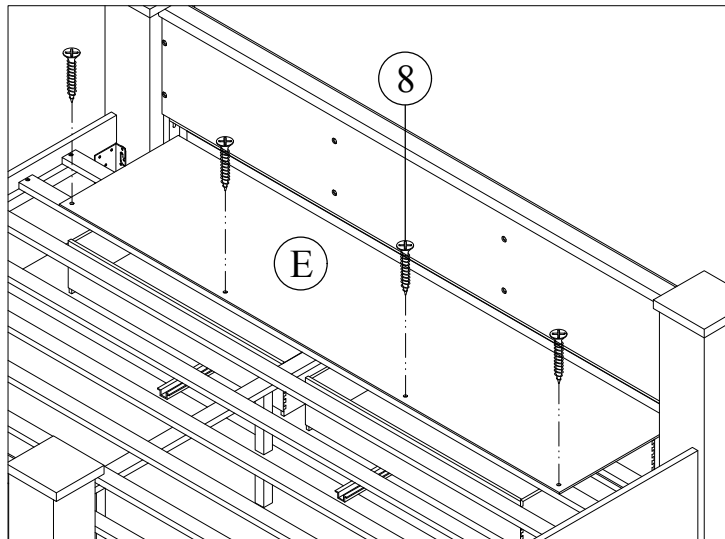

**STEP 5.2**

