



# ASSEMBLY INSTRUCTION

ITEM NO. : 90324T  
90325ST

Thank you for purchasing this quality product. Be sure to check all packing material carefully for small parts which may have come loose inside the carton during shipment. Separate, identify and count all parts and hardware. Compare with the parts list to be sure all parts are present. "DO NOT TIGHTEN SCREWS UNTIL COMPLETELY ASSEMBLED"

IMPORTANT:

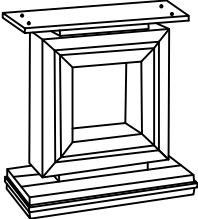
PLEASE READ INSTRUCTION BEFORE STARTING THE ASSEMBLY

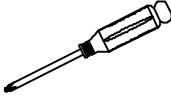
DESCRIPTION	PART NAME	DIMENSIONS	Q'TY(PCS)
1		47.75"X14.25"X3.25"	1PC
2		27.50"X12.50"X28.50"	1PC
3		M0.25"*1.18"	4PCS
4		Ó2047\$	4PCS
5			1PC

Step 1:

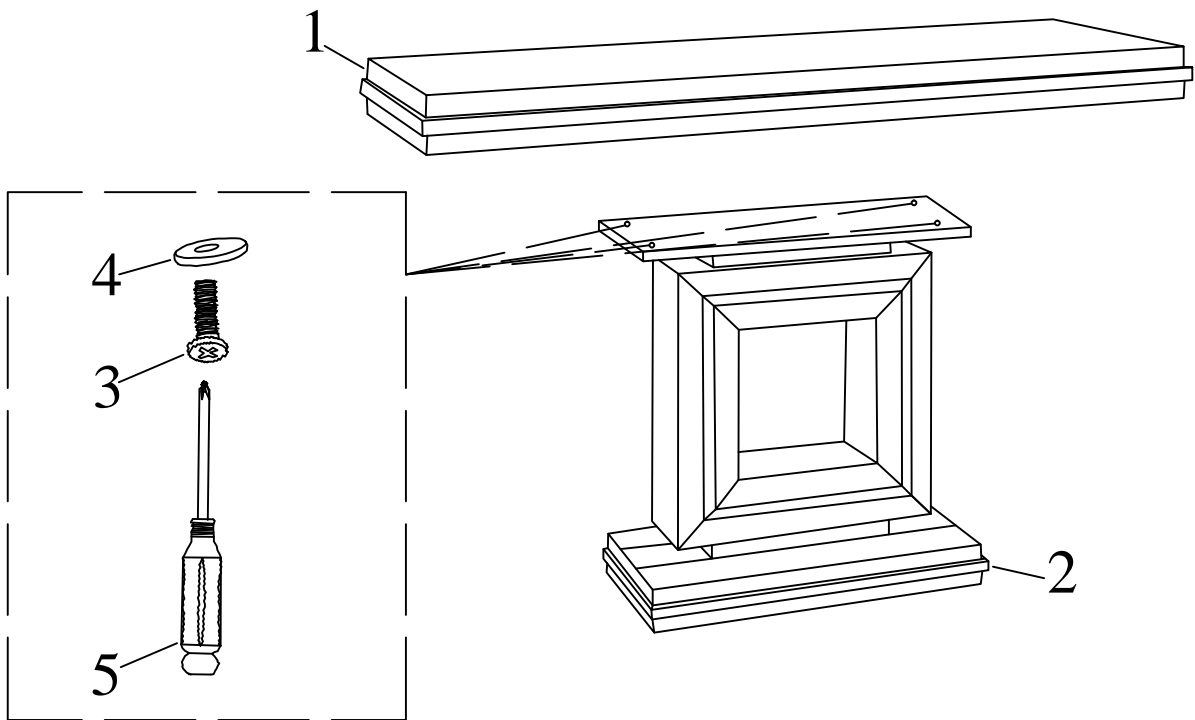

Step 2:

