

ASSEMBLY INSTRUCTION

MODEL : 30624 BED DRAWERS (W935 x D615 x H240)MM

ACME FURNITURE

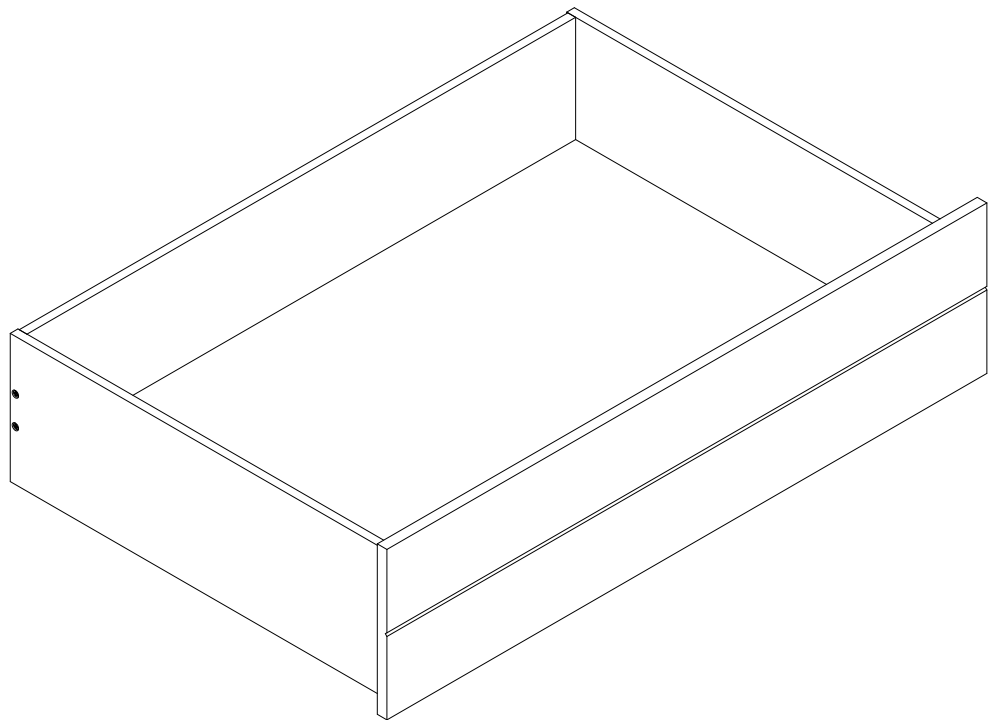
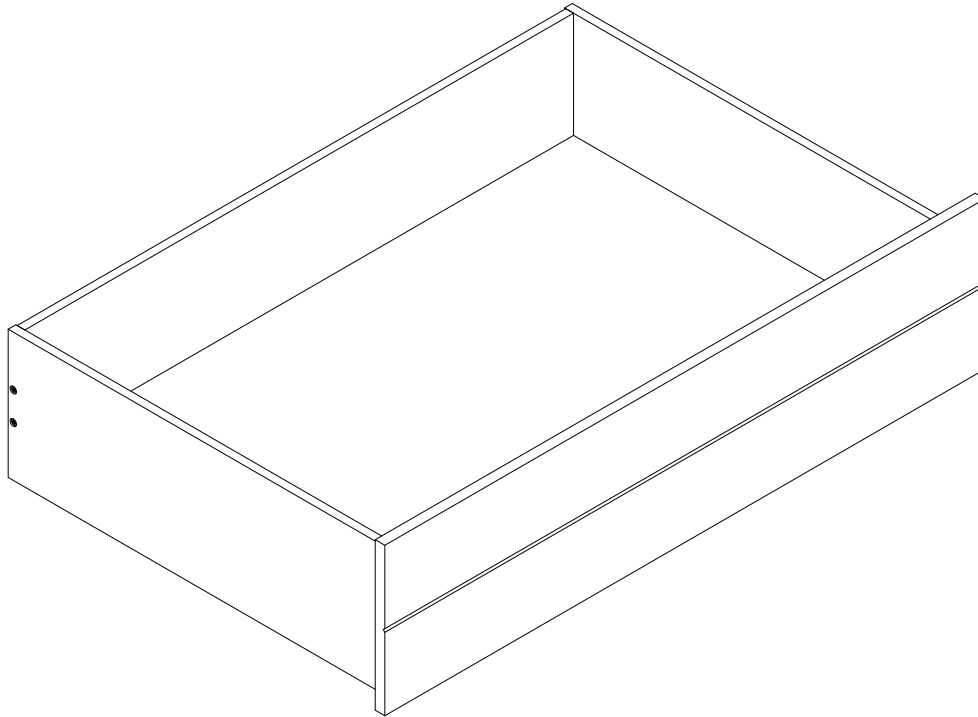

HARDWARE LIST

A **8 PCS**

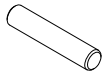

PLASTIC DOWEL (M6 x 30MM)

B **16 PCS**

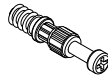

CONNECTING BOLT (24MM)

C **16 PCS**



MINIFIX (9MM)

D **8 PCS**



CSK C/B SCREW (M4 x 32MM)

Tools Required :
Crosshead Screw Driver
Rubber Hammer

PART LIST

1

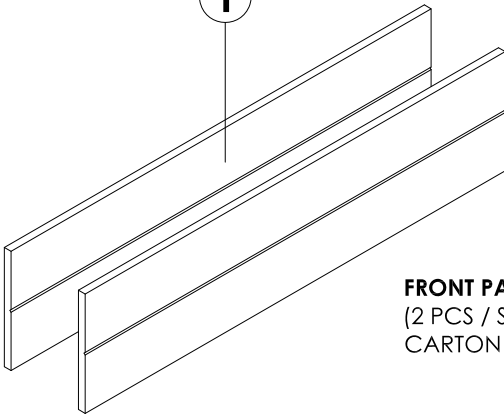

FRONT PANEL
 (2 PCS / SET)
 CARTON 1 OF 1

2L **2R**

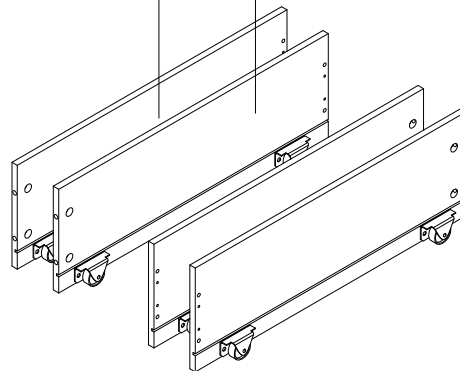

SIDE PANEL (L/R)
 (4 PCS / SET)
 CARTON 1 OF 1

3

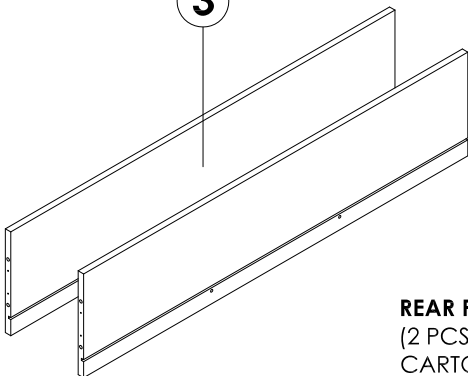

REAR PANEL
 (2 PCS / SET)
 CARTON 1 OF 1

4

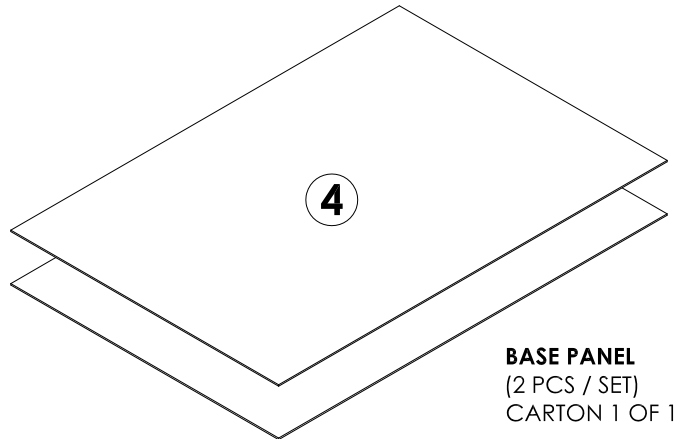

BASE PANEL
 (2 PCS / SET)
 CARTON 1 OF 1

5

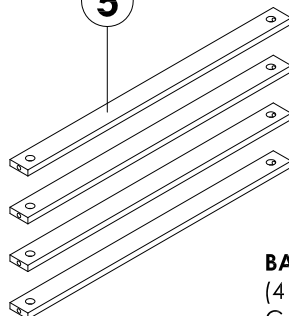

BASE SUPPORT
 (4 PCS / SET)
 CARTON 1 OF 1

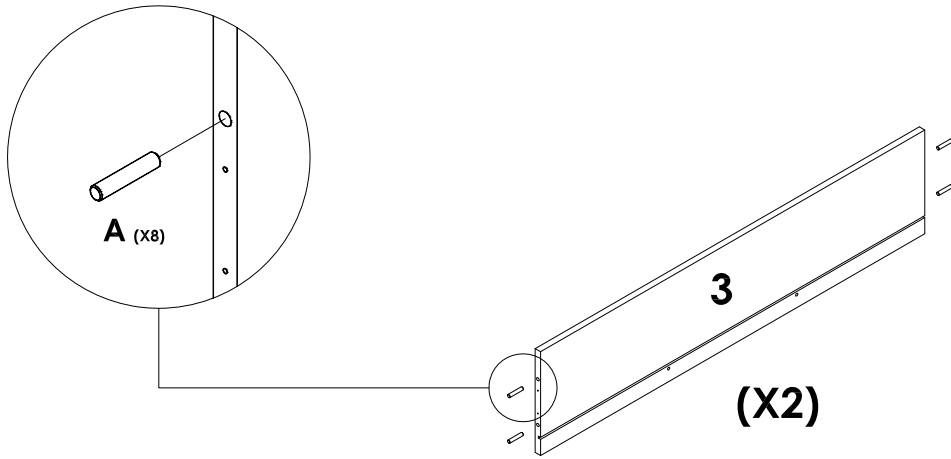

STEP 1

Insert **(A)** into $\varnothing 6$ MM holes on **Rear Panel** by using Rubber Hammer.

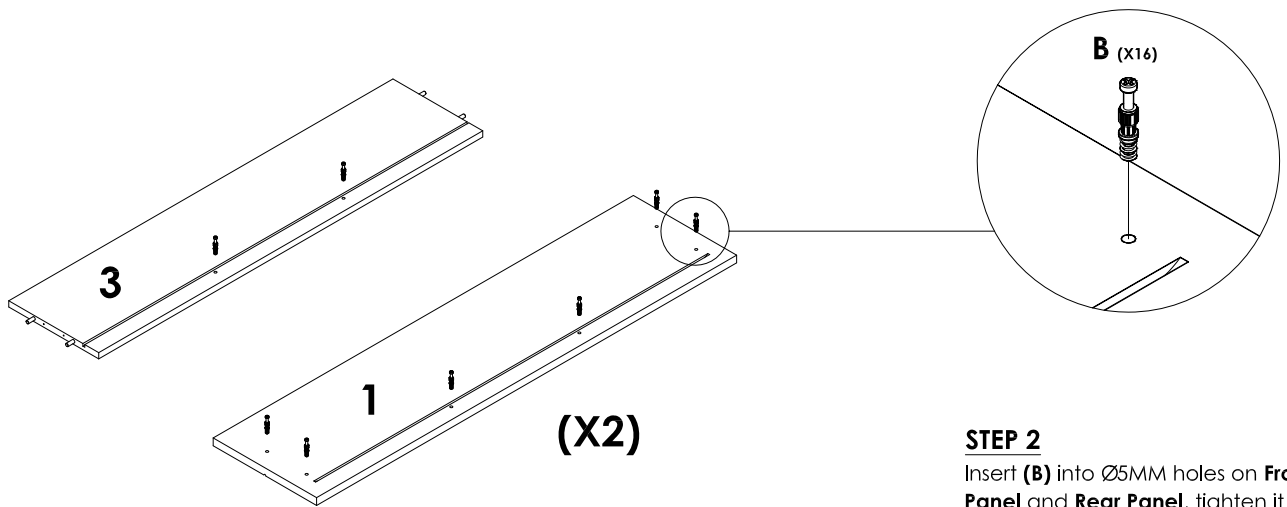

STEP 2

Insert **(B)** into $\varnothing 5$ MM holes on **Front Panel** and **Rear Panel**, tighten it up by using Crosshead Screw Driver.

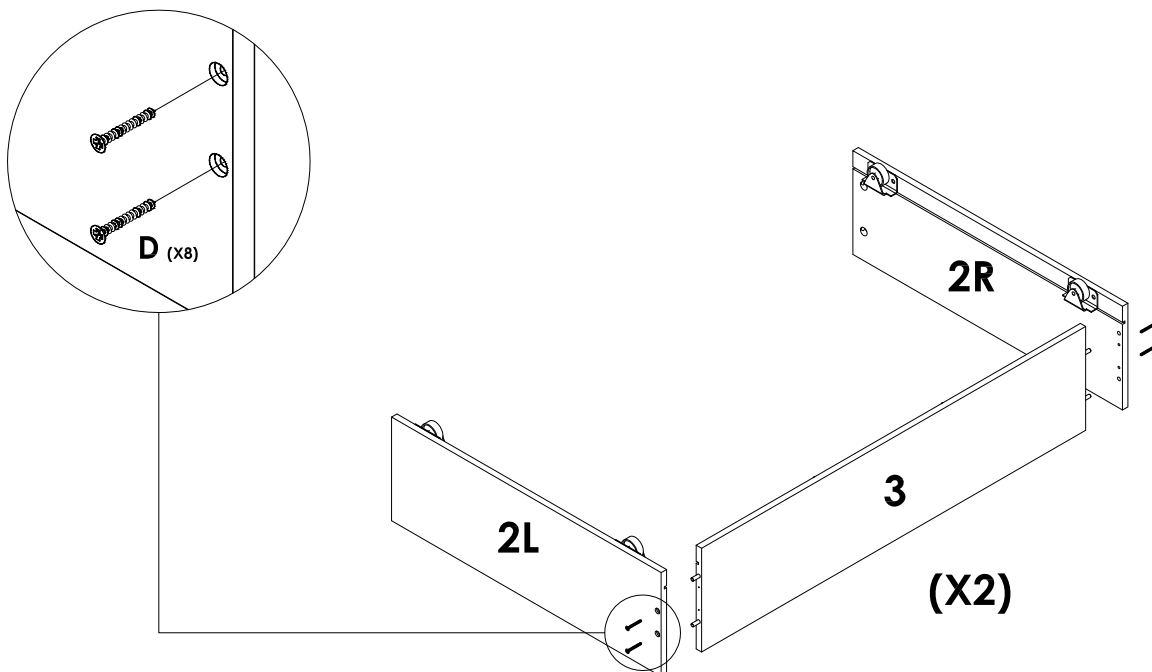

STEP 3

Attach and secure **Side Panel (L/R)** onto **Rear Panel** and insert **(D)** to tighten it up by using Crosshead Screw Driver.

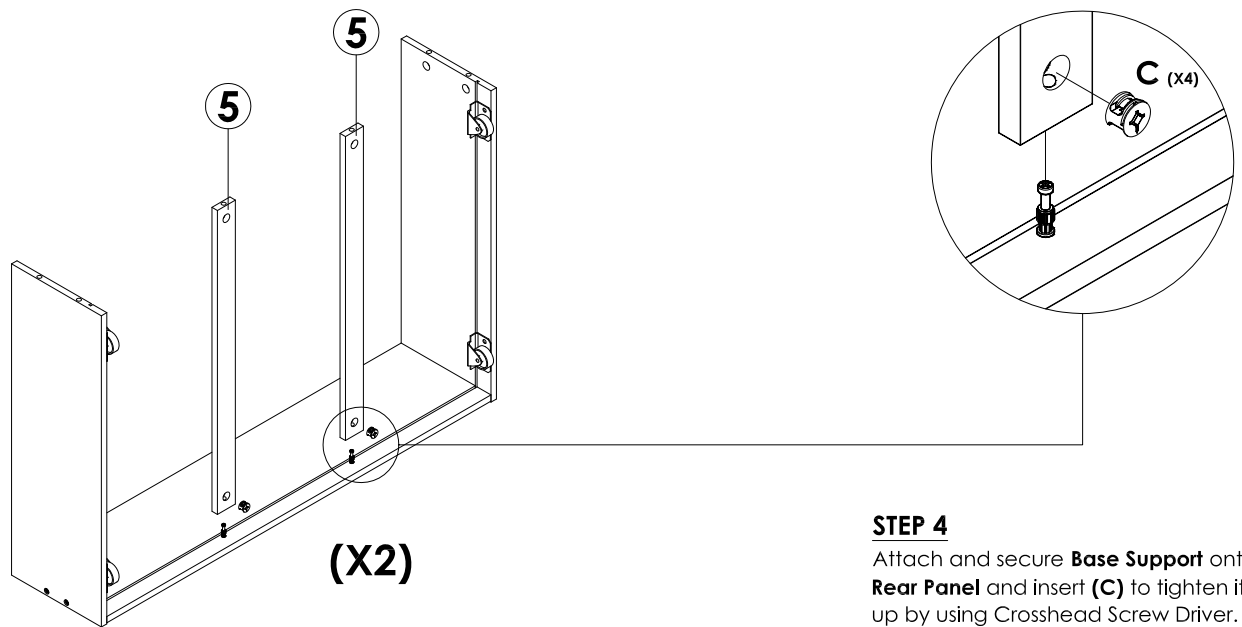

STEP 4

Attach and secure **Base Support** onto **Rear Panel** and insert **(C)** to tighten it up by using Crosshead Screw Driver.

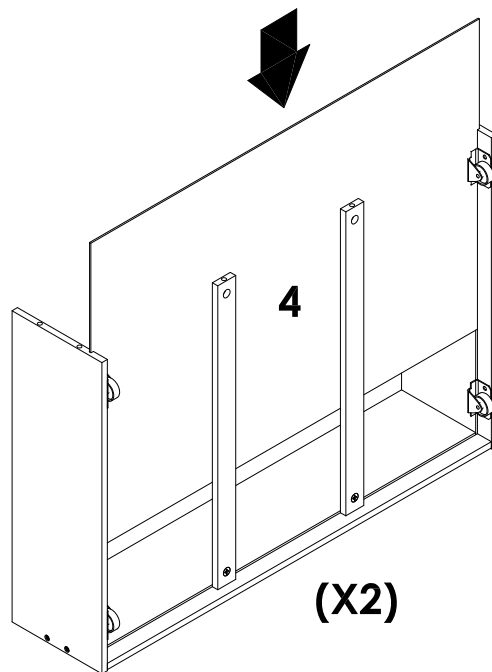

STEP 5

Slot **Base Panel** into the groove provided at previous assembly.

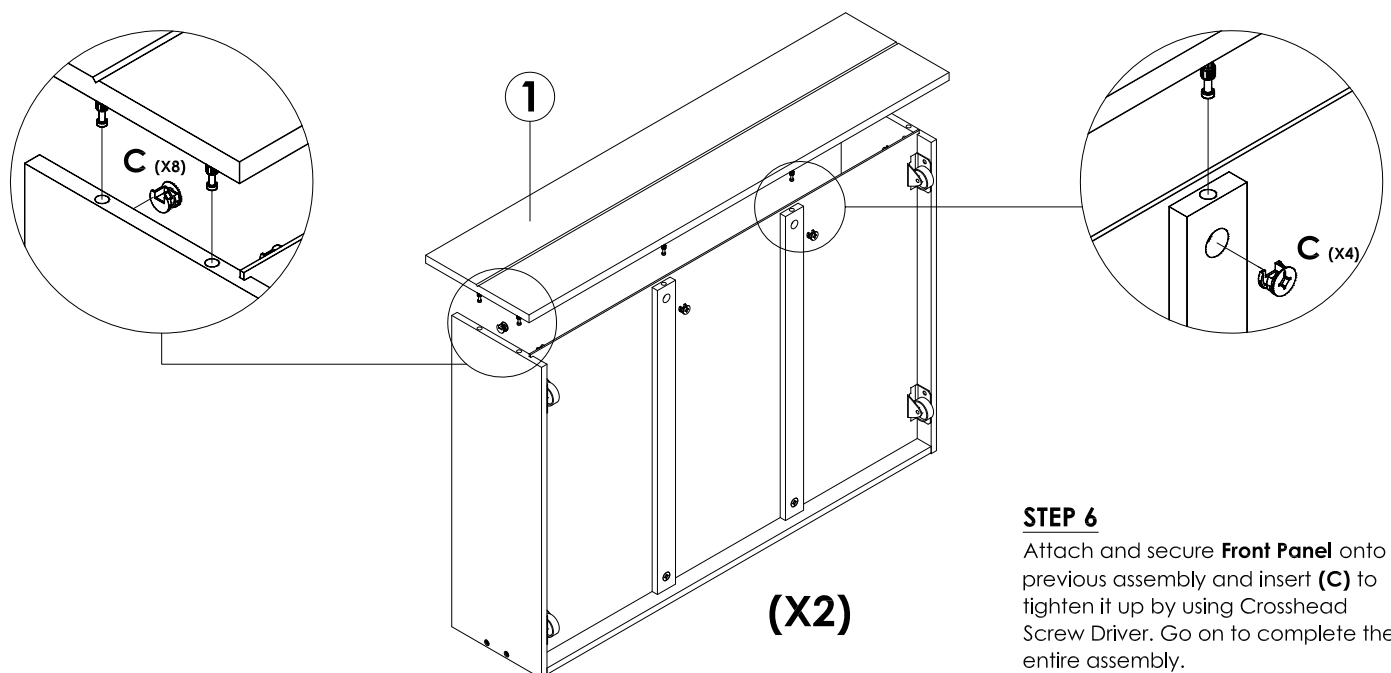

STEP 6

Attach and secure **Front Panel** onto previous assembly and insert **(C)** to tighten it up by using Crosshead Screw Driver. Go on to complete the entire assembly.