

ASSEMBLY INSTRUCTIONS

80585

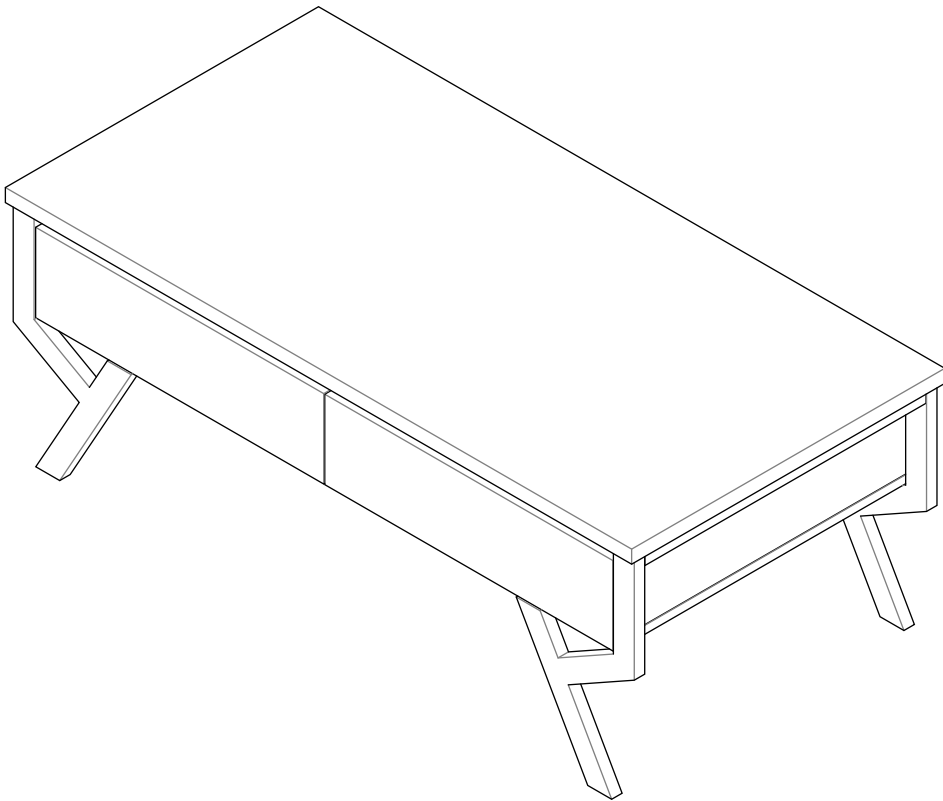

COFFEE TABLE

COFFEE TABLE

80585

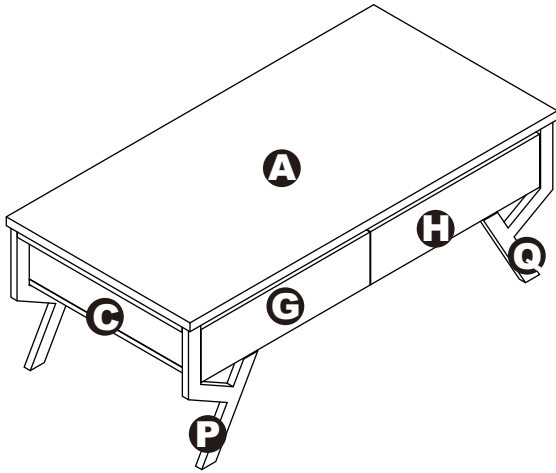





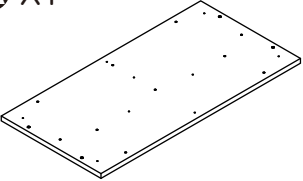
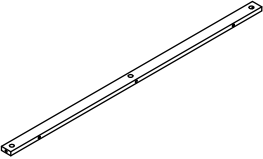
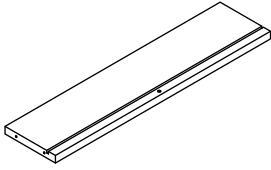
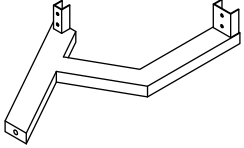
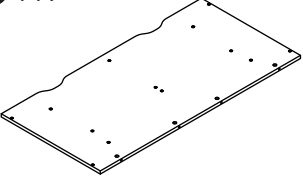
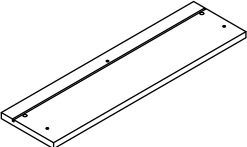
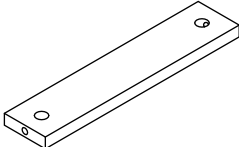
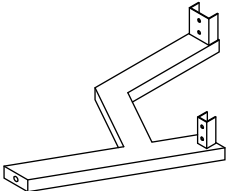
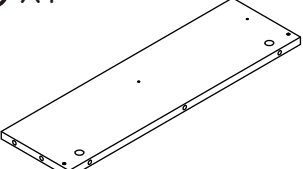
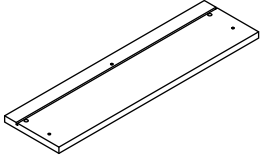
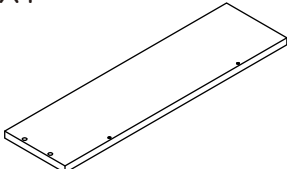
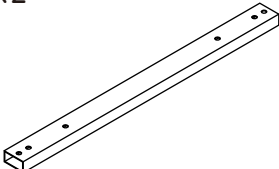
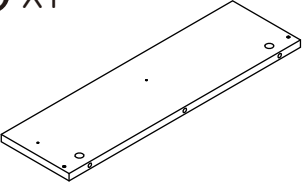
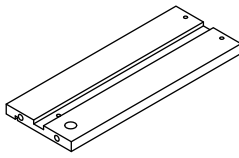
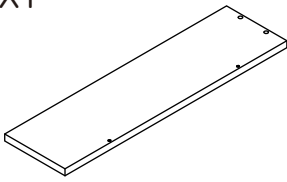
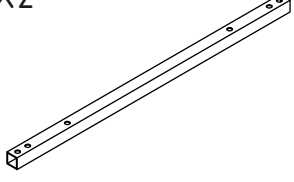
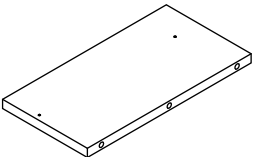
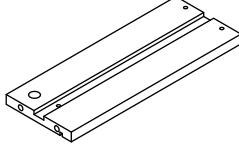
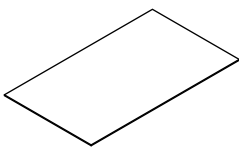
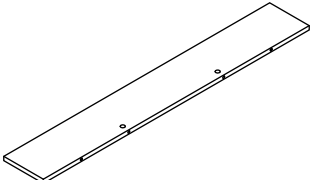

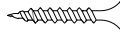

DIMENSIONS
 Width - 47.24"
 Depth - 23.62"
 Height - 17.49"

PARTS LIST

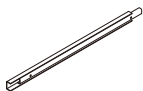
A X1 	F X2 	K X2 	P X2 
B X1 	G X1 	L X2 	Q X2 
C X1 	H X1 	M X1 	R X2 
D X1 	I X2 	N X1 	S X2 
E X1 	J X2 	O X2 	T X1 

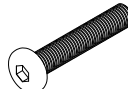
HARDWARE LIST

1 X25 	2 X25 	3 X18 	4 X8 	5 X9 	6 X4 
7 X8 	8 X4 	9 X8 	10 X16 	11 X4 	

ASSEMBLY INSTRUCTIONS

Step 1.

Push runner to see screw holes on the other end

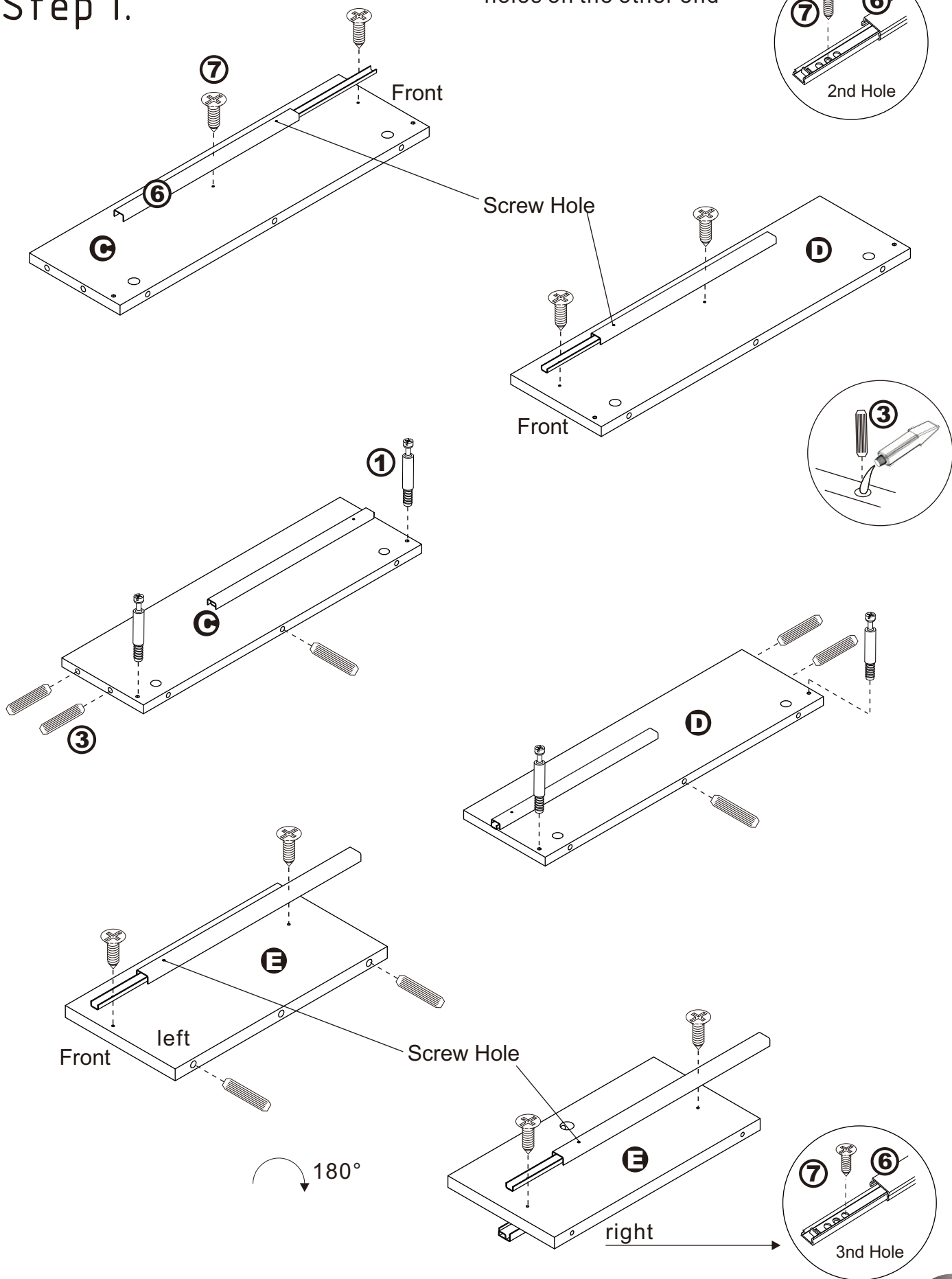

ASSEMBLY INSTRUCTIONS

Step 2.

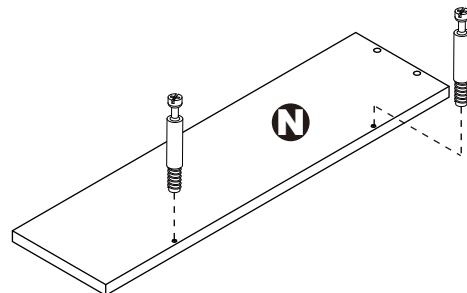
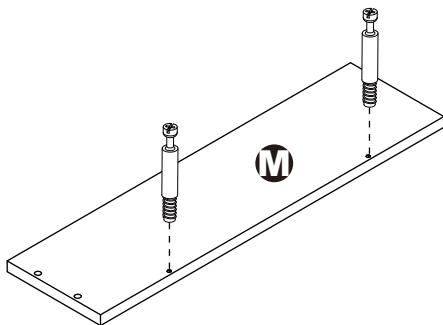
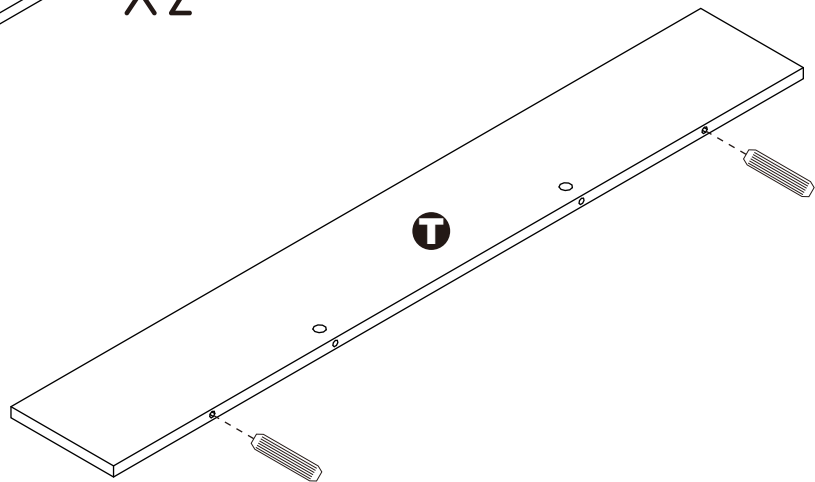
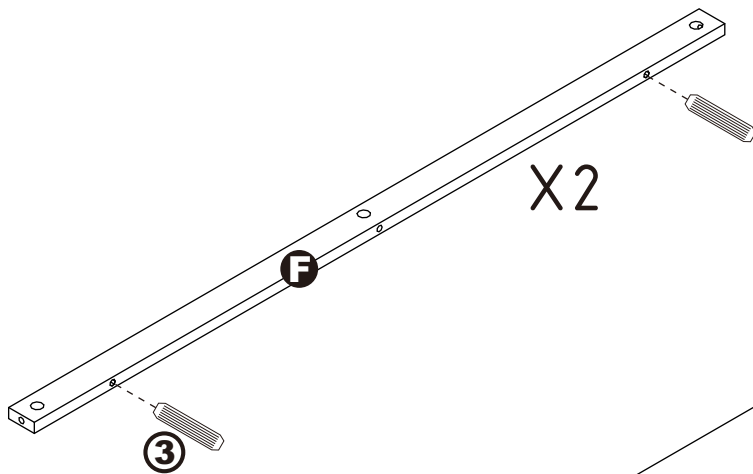
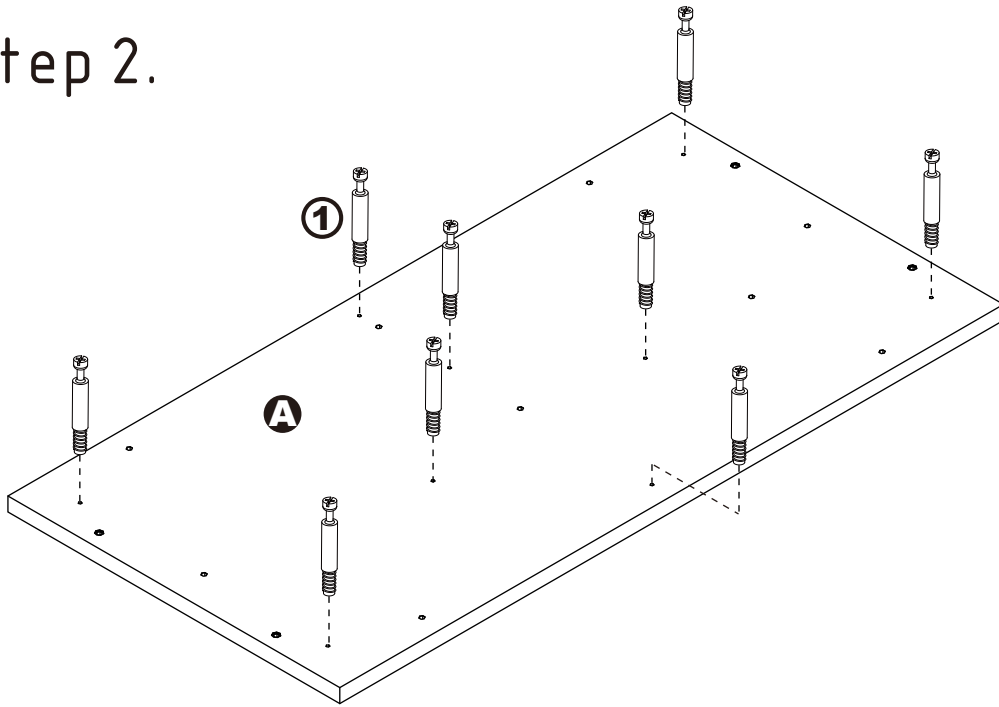

ASSEMBLY INSTRUCTIONS

Step 3.

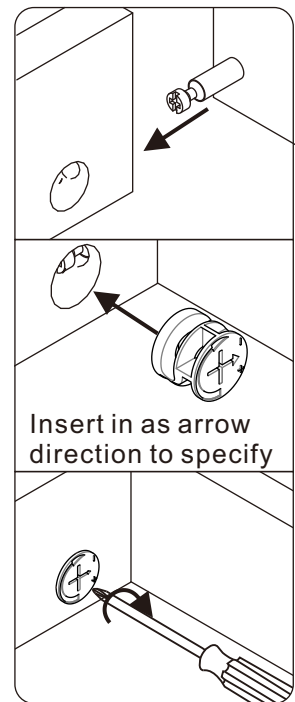
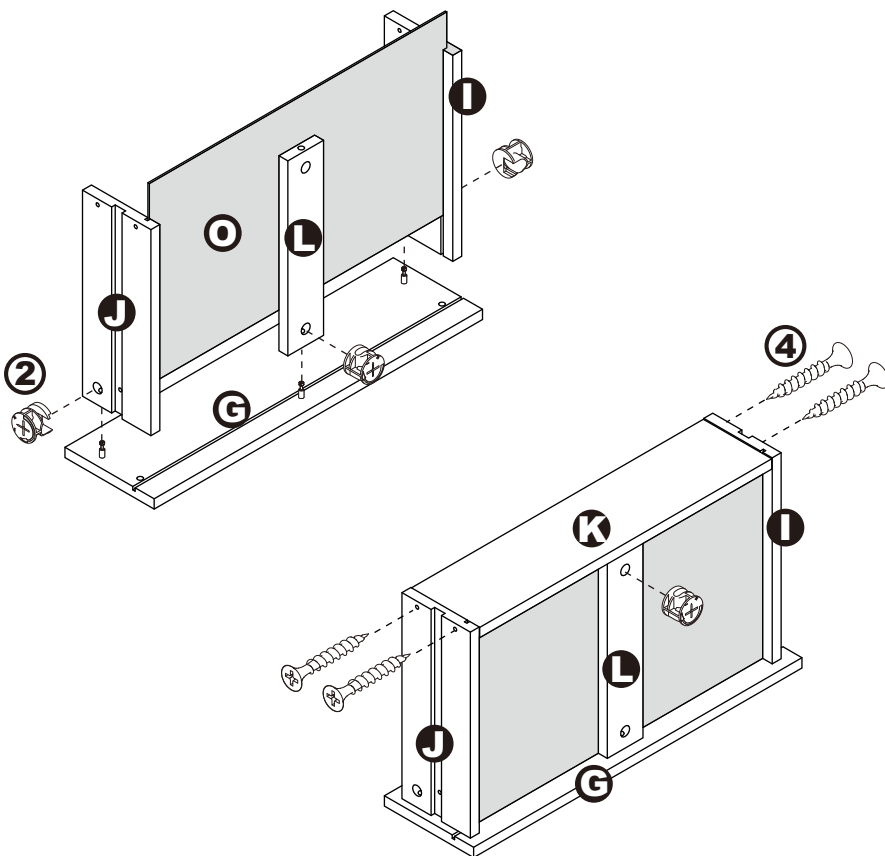
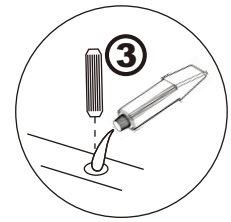
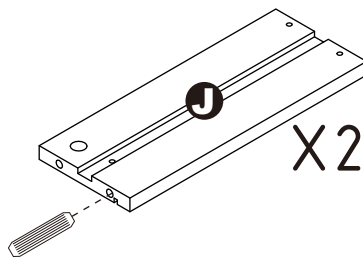
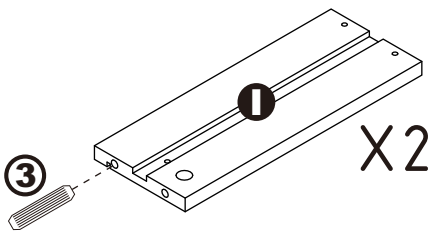
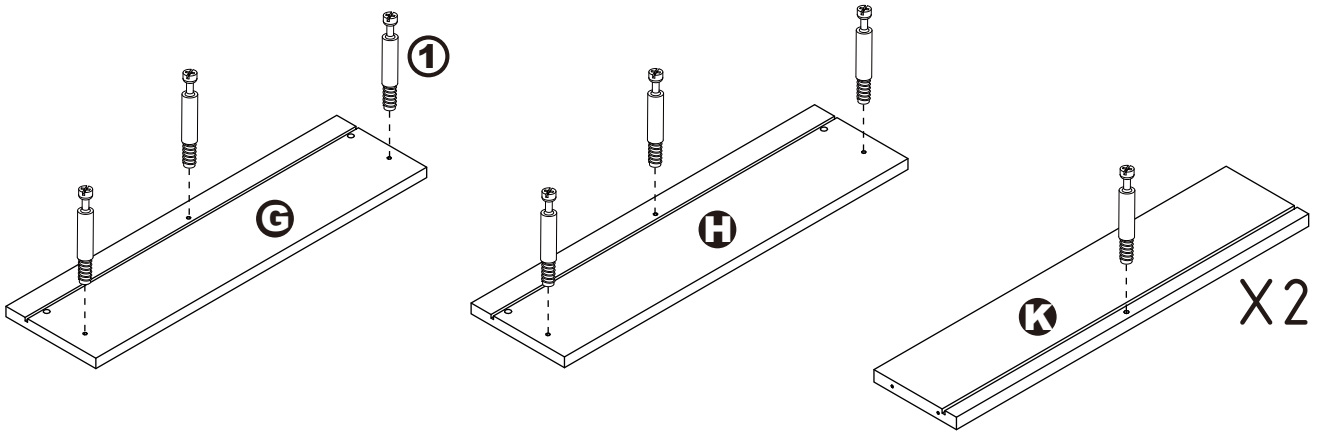

ASSEMBLY INSTRUCTIONS

Step 4.

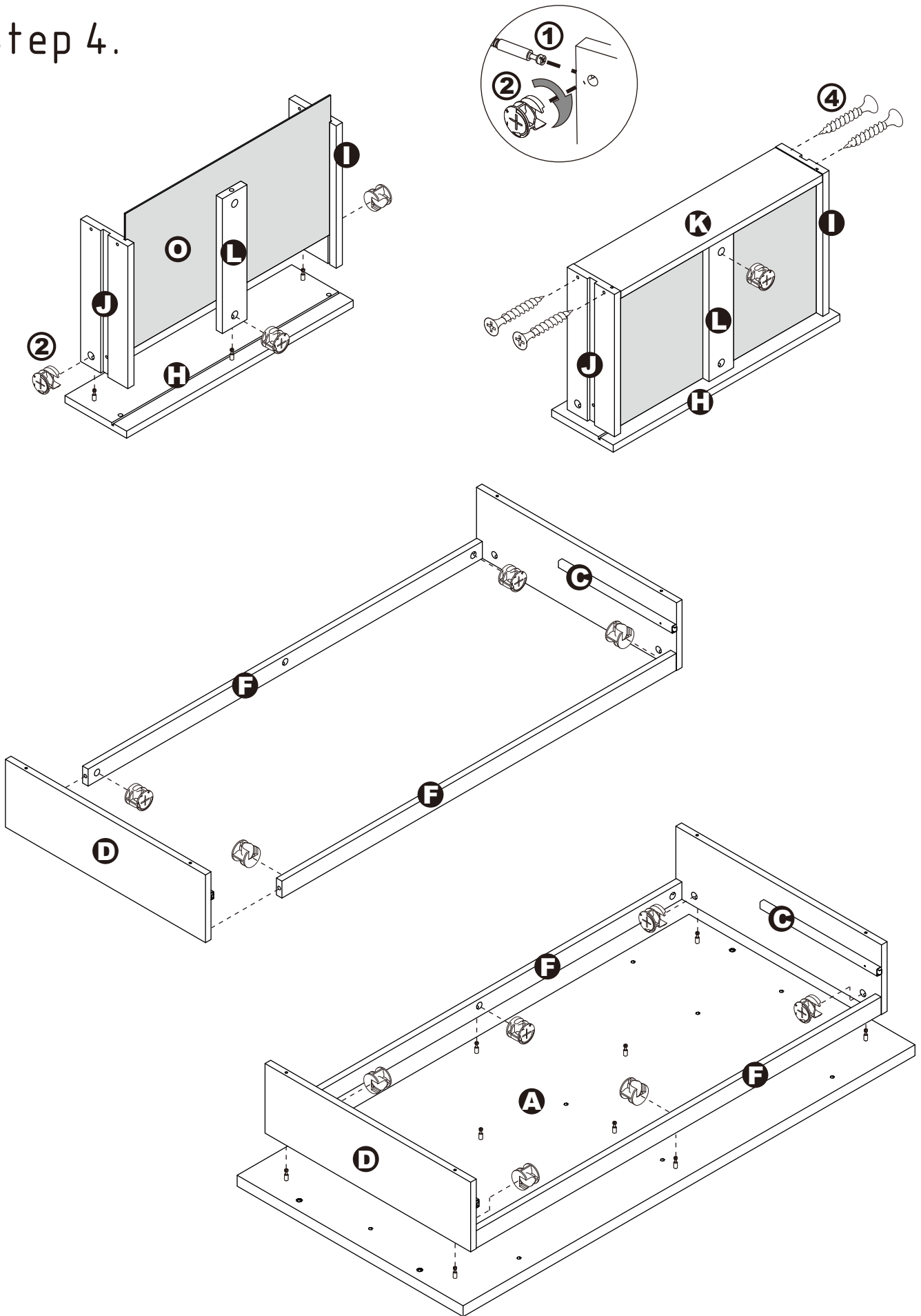

ASSEMBLY INSTRUCTIONS

Step 5.

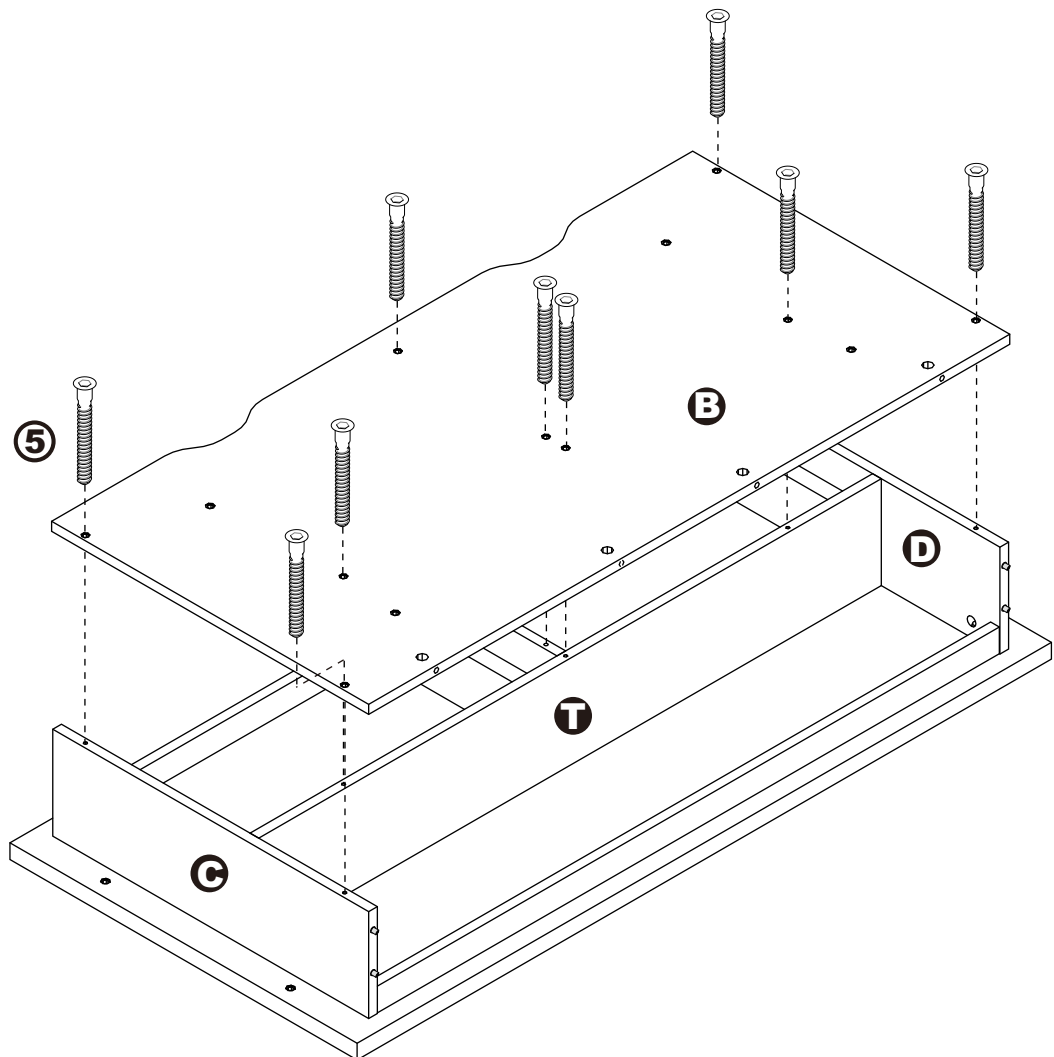
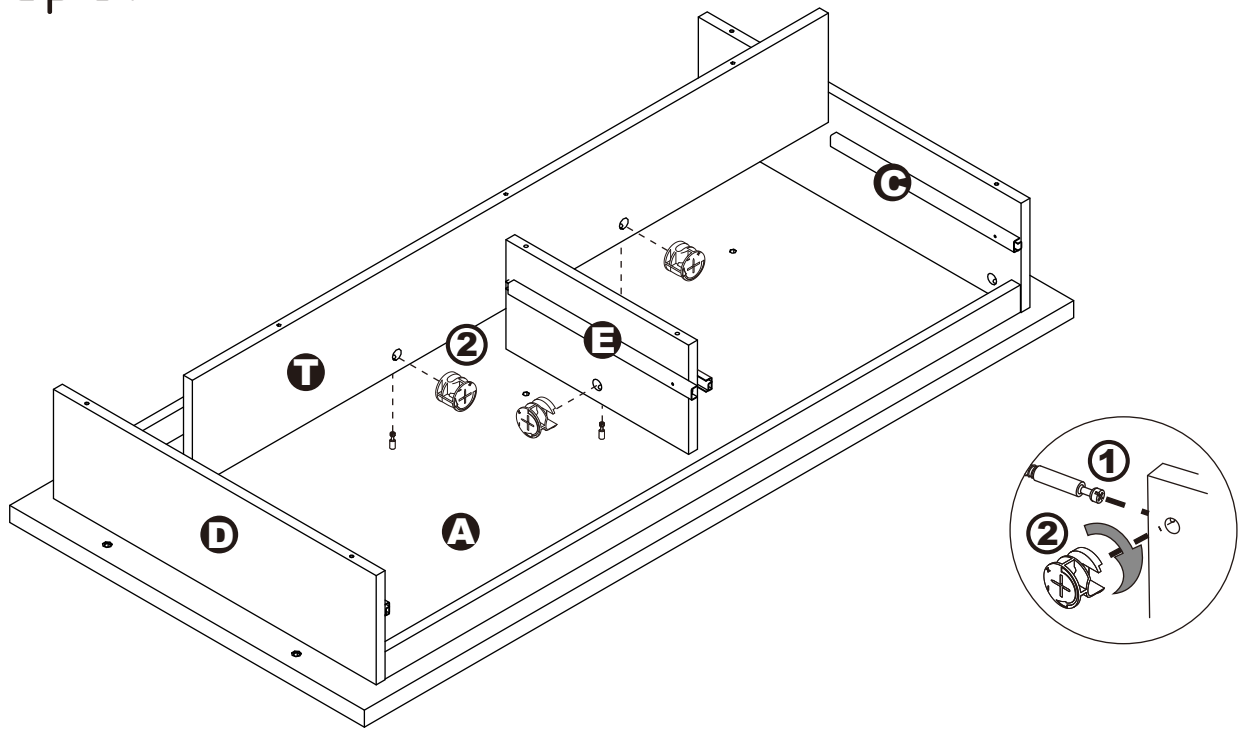

ASSEMBLY INSTRUCTIONS

Step 6.

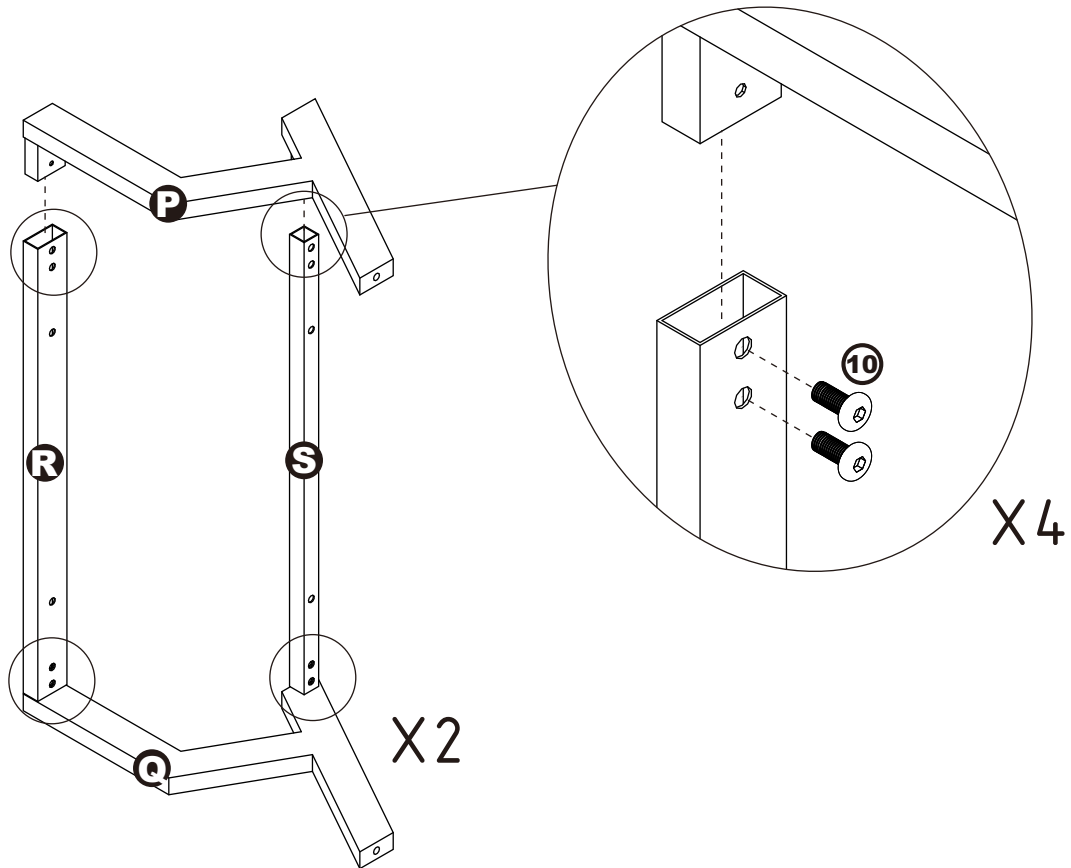
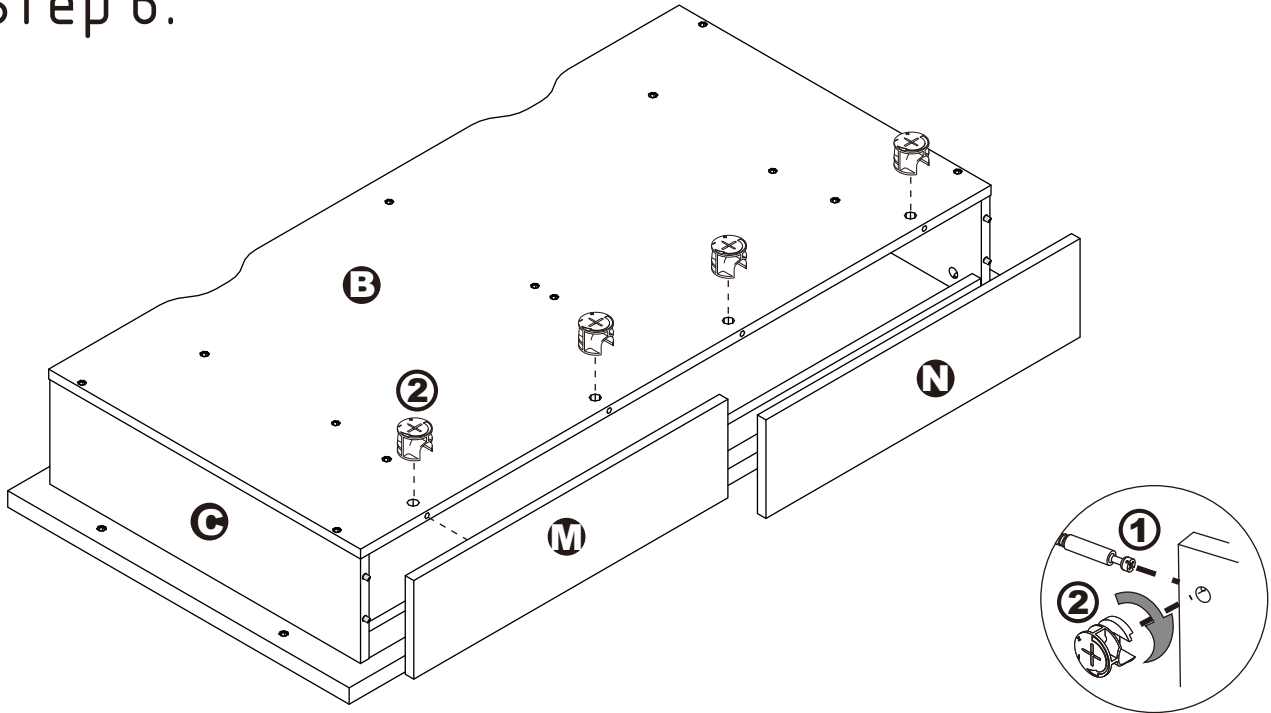

ASSEMBLY INSTRUCTIONS

Step 7.

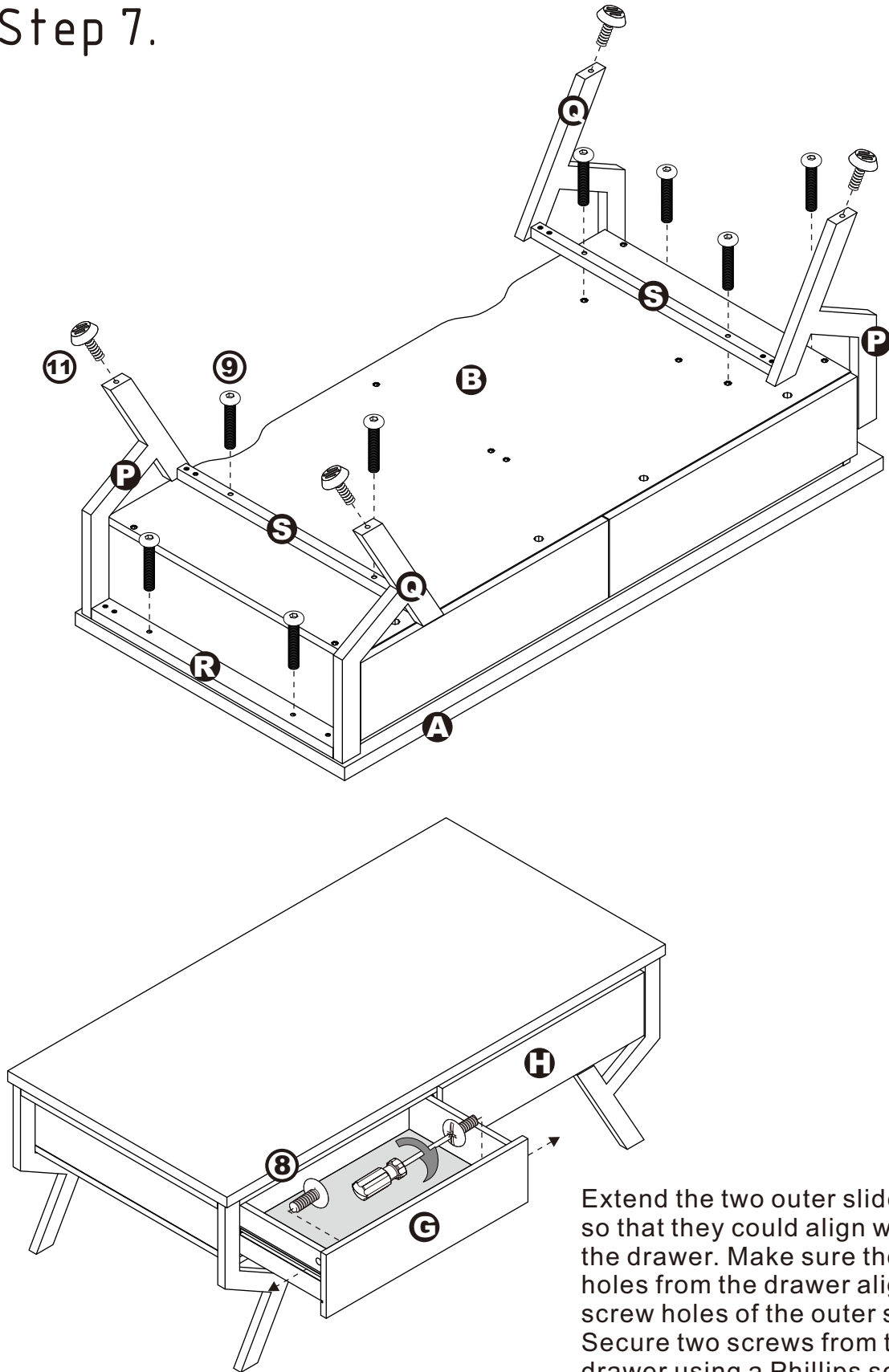

Extend the two outer slides of the runners so that they could align with the sides of the drawer. Make sure the pre-drilled holes from the drawer align with the screw holes of the outer slides. Secure two screws from the inside of the drawer using a Phillips screwdriver to tighten them to the outer slides.

ASSEMBLY IS COMPLETED

Make sure the product is rested on a flat surface and does not feel loose or wobbly. If it does, double check that the bolts/screws are secured and properly tightened.