

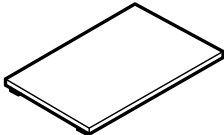

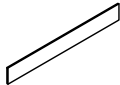

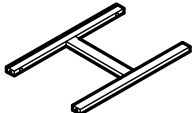



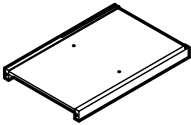

ASSEMBLY INSTRUCTION FOR ACME FURNITURE

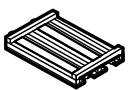
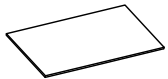
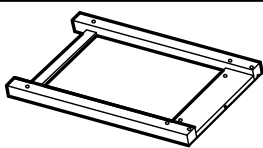
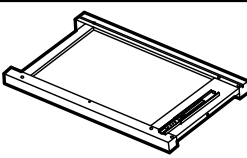
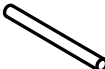
MODEL#98320



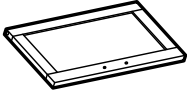
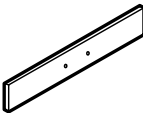
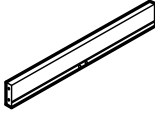

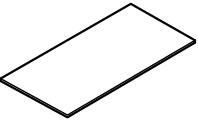

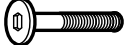

Thank you for purchasing the quality product. Be sure to check all packing material carefully for small parts which may have come loose inside the carton during shipment. Separate, identify and count all parts and metal hardware. Compare with all parts list to be sure all parts are present. If any part(s) are missing or damaged, please contact your local furniture dealer. For efficient and speedy service, please indicate the model number and code letter of part(s) needed.

*** Do not fully tighten screws until fully assembled ***

COMPONENT PARTS		
DESCRIPTION	PART NAME	QTY (PCS)
①	TOP 	1
②	BACK PANEL UP 	1
③	TOP FRAME 	1
④	DIVISION PANEL 	1
⑤	BOTTOM PANEL 	1
⑥	SHELF 	2
⑦	WINE RACK 	1
⑧	BACK PANEL - DOWN 	1
⑨	SIDE FRAME - LEFT 	1
⑩	SIDE FRAME - RIGHT 	1
⑪	ROD TOWEL 	1
⑫	HOLDER 	2

COMPONENT PARTS			
DESCRIPTION	PART NAME		QTY (PCS)
13	DOOR		1
14	DRAWER HEAD		1
15	DRAWER BACK PANEL		1
16	DRAWER SUPPORT		1
17	DRAWER BOTTOM PANEL		1
18A	DRAWER SIDE PANEL - LEFT		1
18B	DRAWER SIDE PANEL - RIGHT		1

HARDWARE REQUIRED

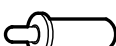
A		BOLT	M6 x 40mm	2 PCS
B		BOLT	M6 x 60mm	12 PCS
C		BARREL NUT	M6 x 13mm	12 PCS
D		FLAT WASHER	1/4"	2 PCS
E		ALLEN KEY	M4 x 100mm	1 PC
F		WOOD PLUG	10.5Ø	12 PCS
G		CHIPBOARD SCREW	M3.5 x 32mm	8 PCS
H		MAGNETIC CATCH		1 PC
I		CHIPBOARD SCREW	M3 x 16mm	6 PCS
J		DOOR SPRING		2 PCS

(K)		CAM-LOCK	9mm	6 PCS
(L)		MINIFIX	24mm	6 PCS
(M)		HANDLE		2 PCS
(N)		TRUSS HEAD	20mm	4 PCS
(O)		SHELF SUPPORT		8 PCS
(P)		CASTER WITH BREAK	50mm	2 PCS
(Q)		CASTER W/O BREAK	50mm	2 PCS

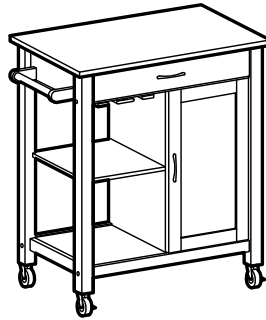

Attention

*** Some number parts listed on the instruction sheet may not to be in parts bag as they already be assembled. Carefully check parts and packing materials prior to ordering replacements.

How to assemble :

STEP 1

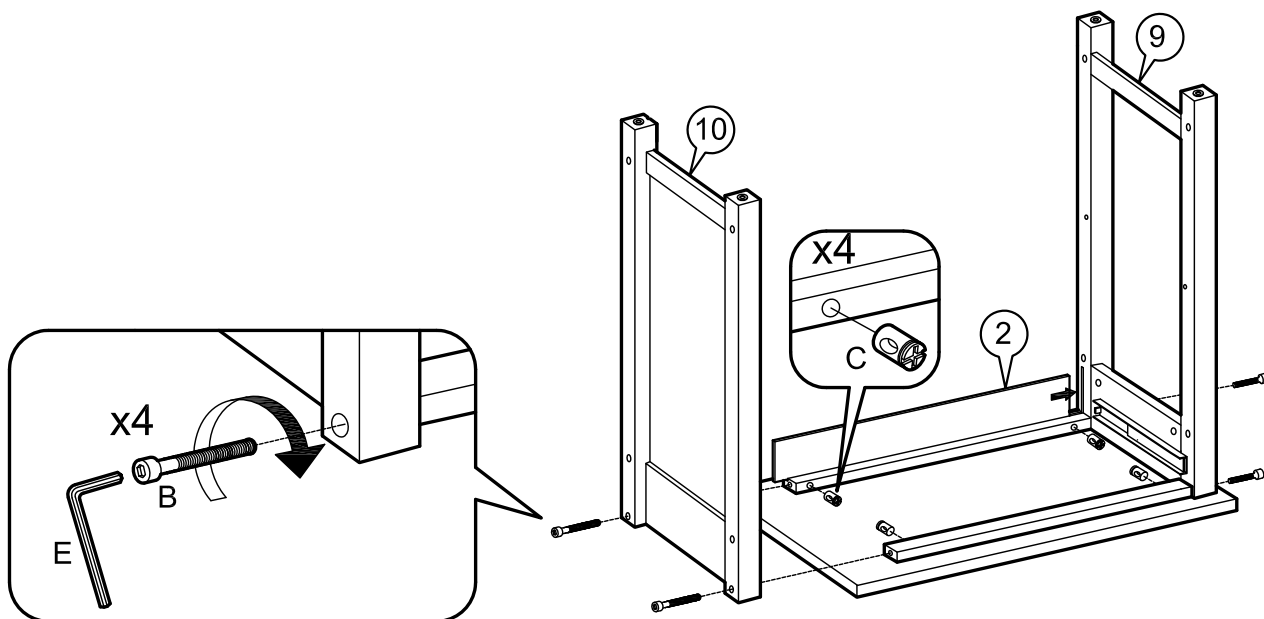

STEP 2

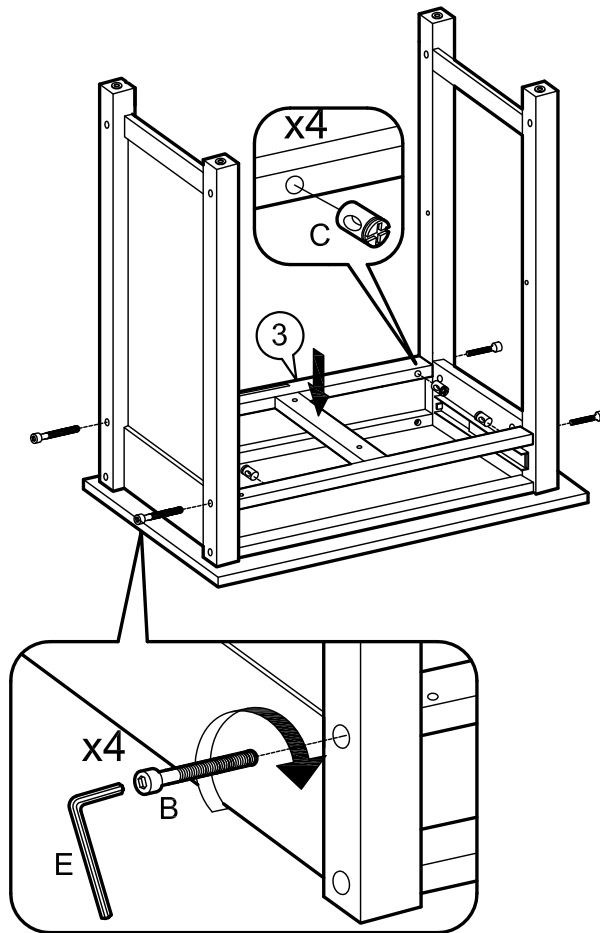

STEP 3

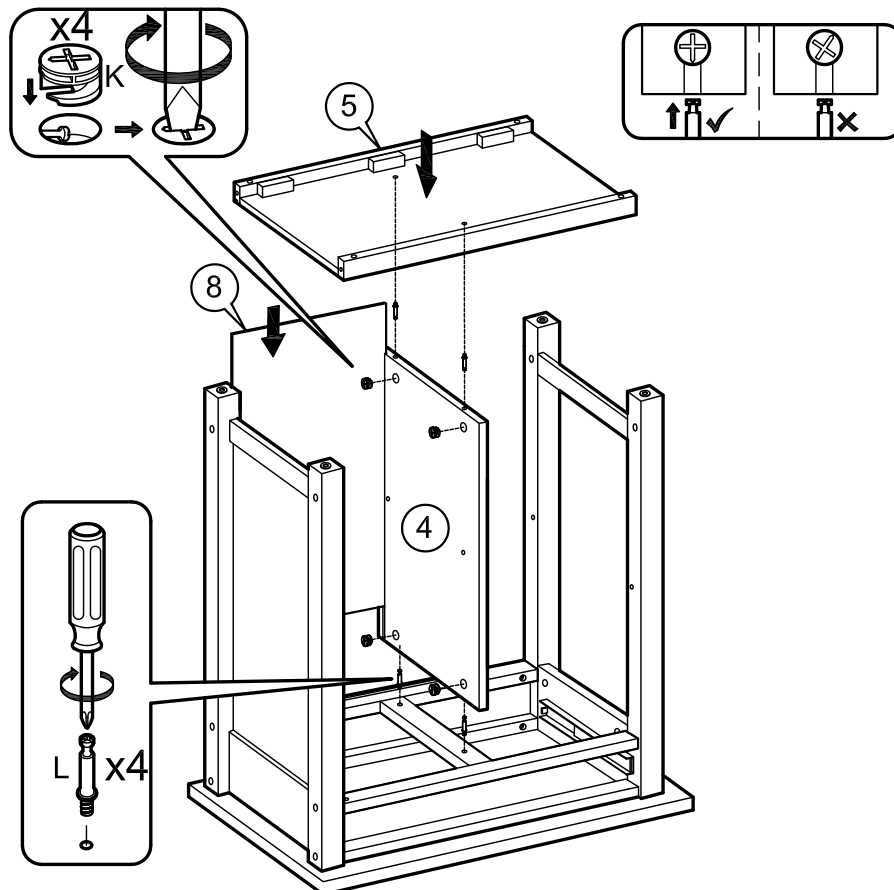

STEP 4

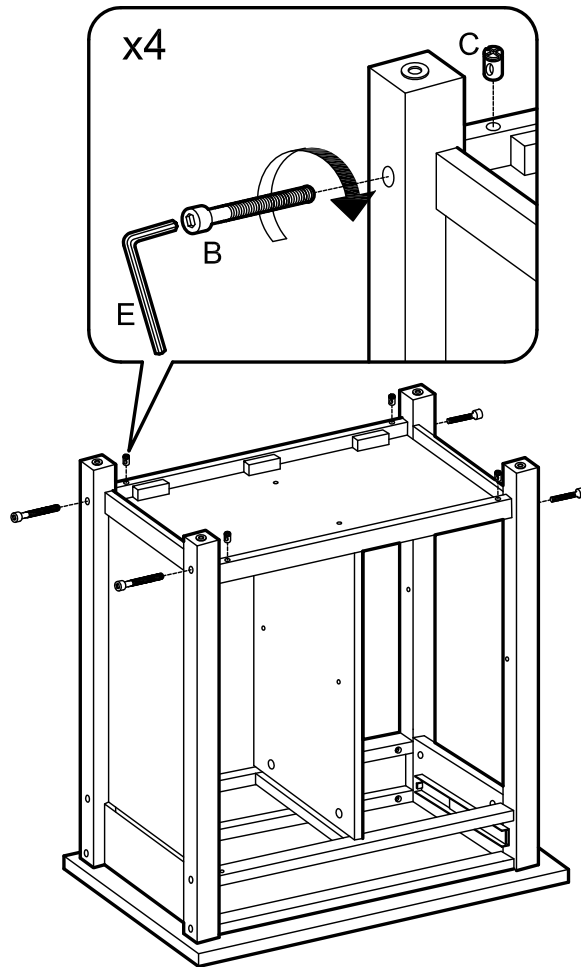

STEP 5

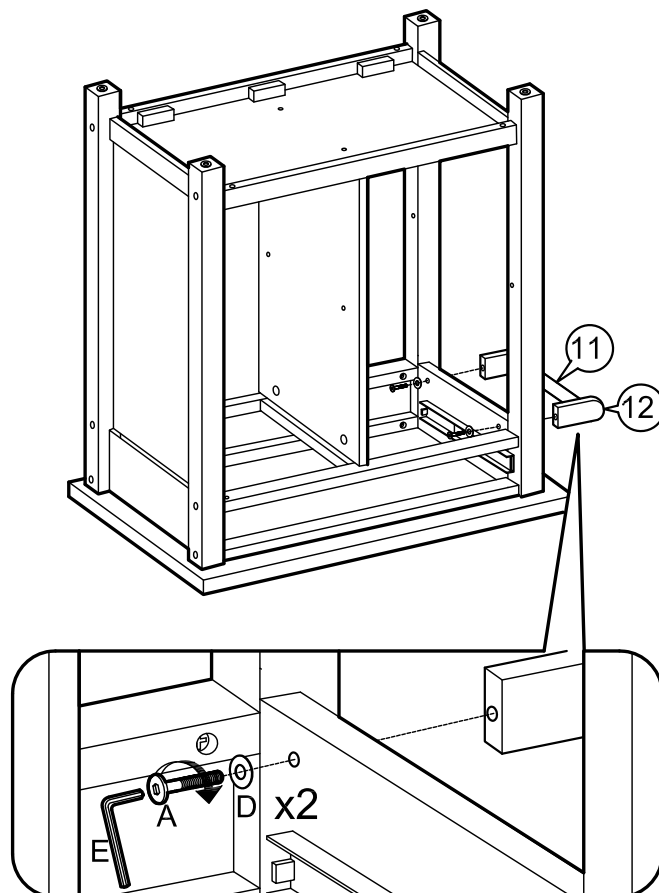

STEP 6

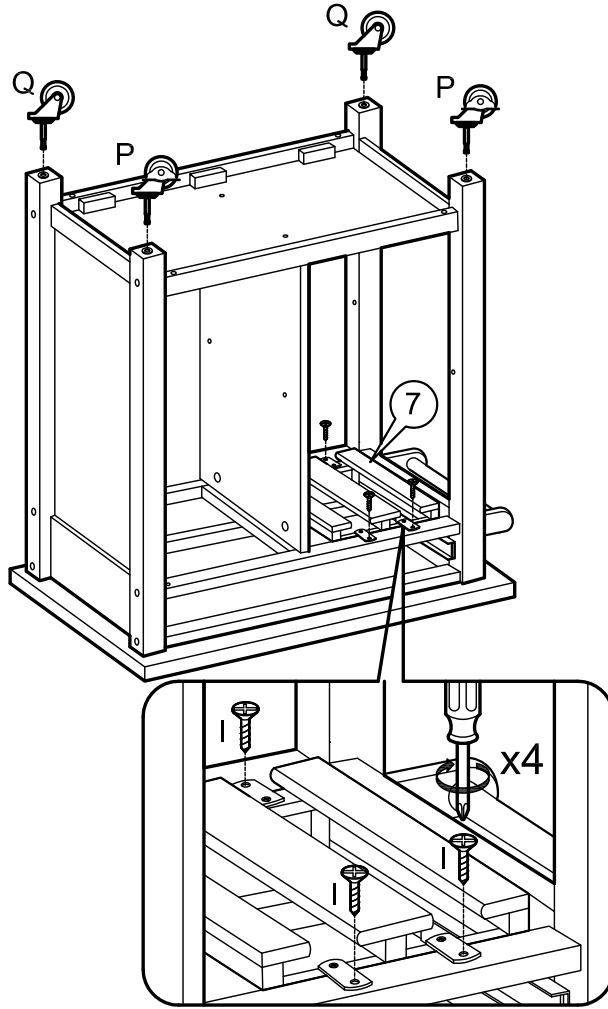

STEP 7

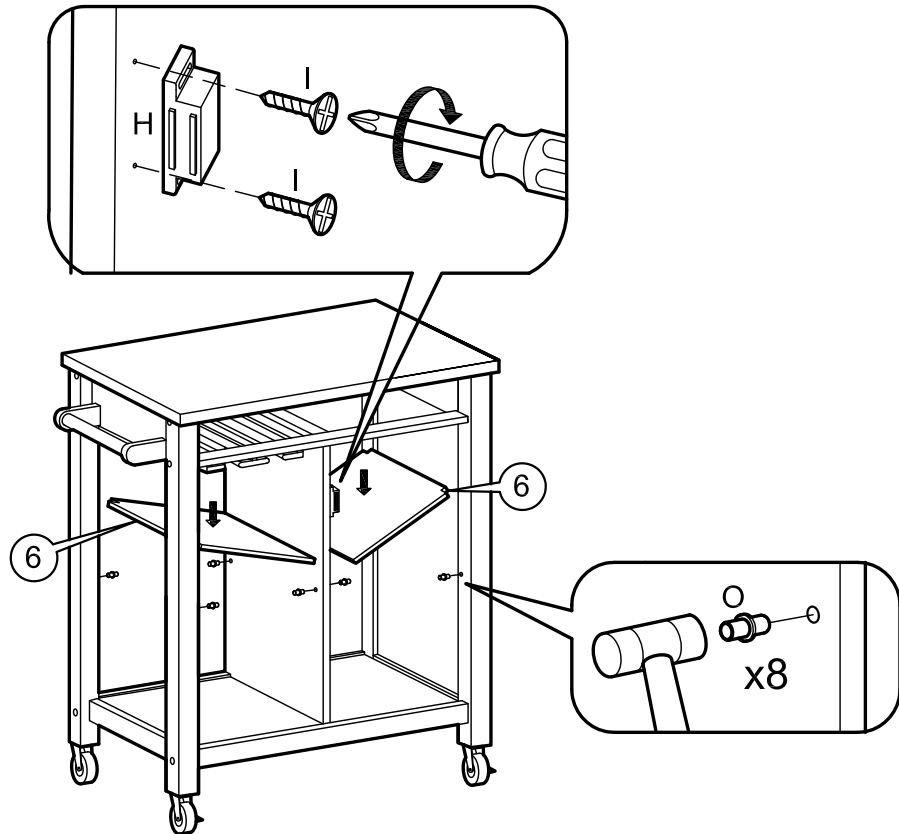

STEP 8

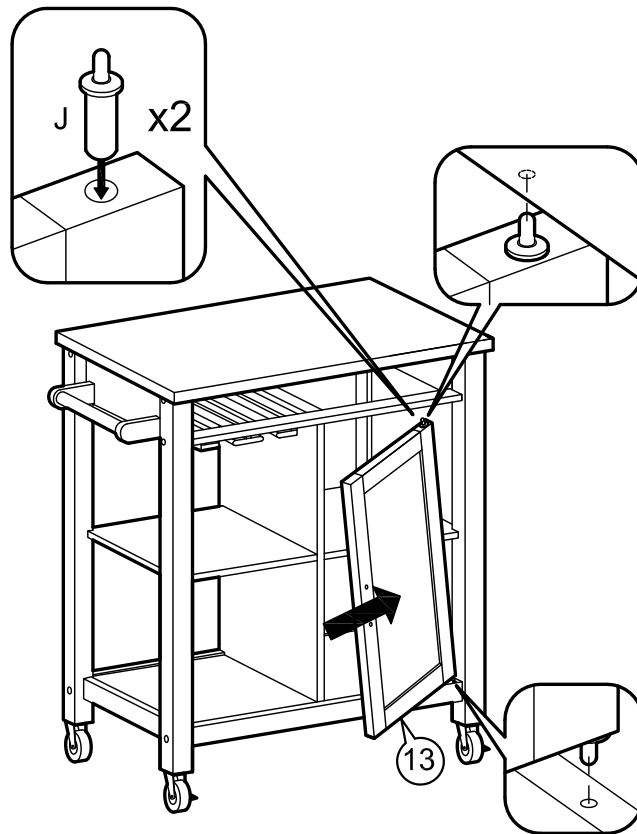

STEP 9

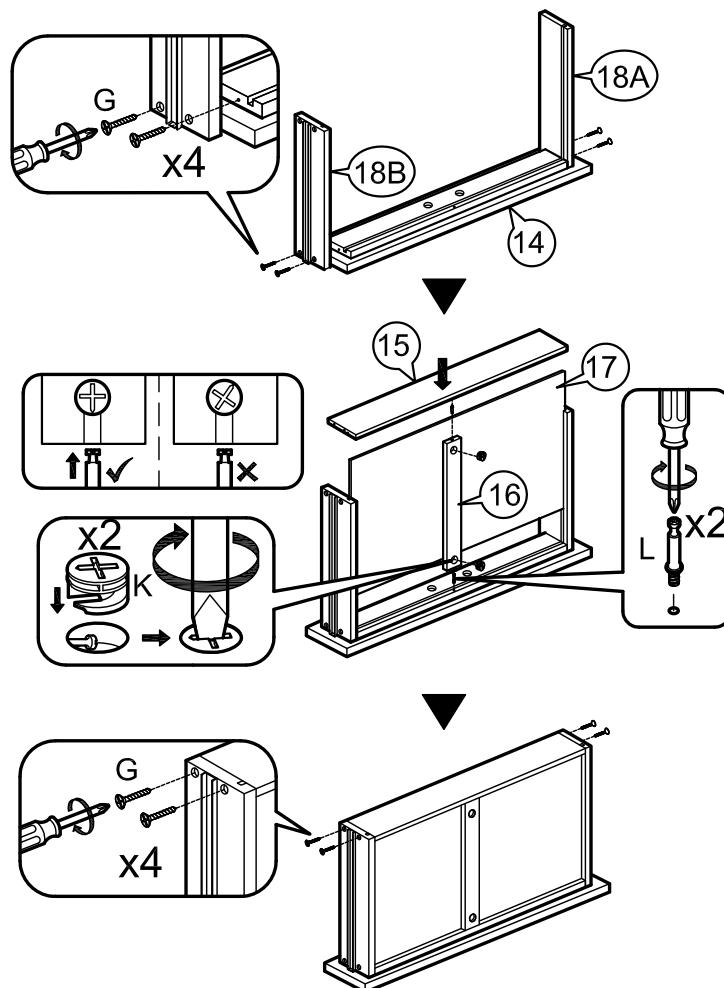

STEP 10

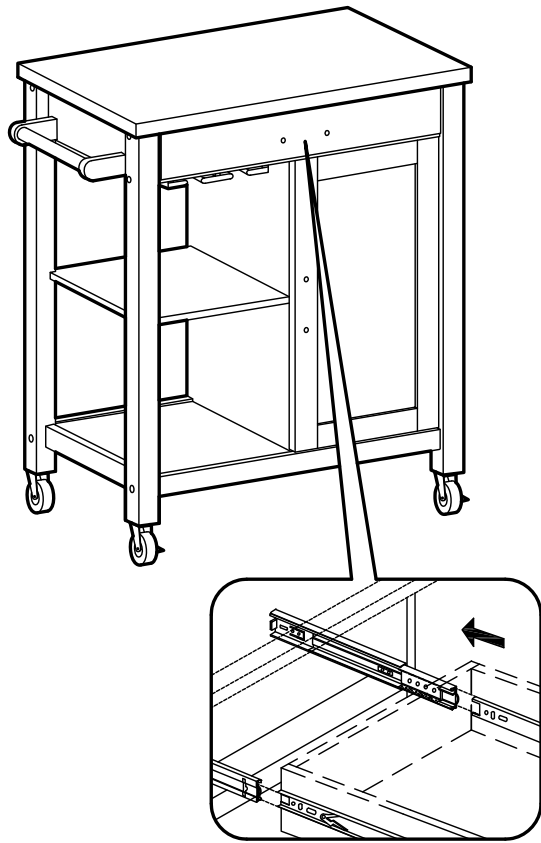

STEP 11

