

# ASSEMBLY INSTRUCTION

MODEL : 37715 BUNK BED (990 x 1905)MM

Page 1

ACME FURNITURE

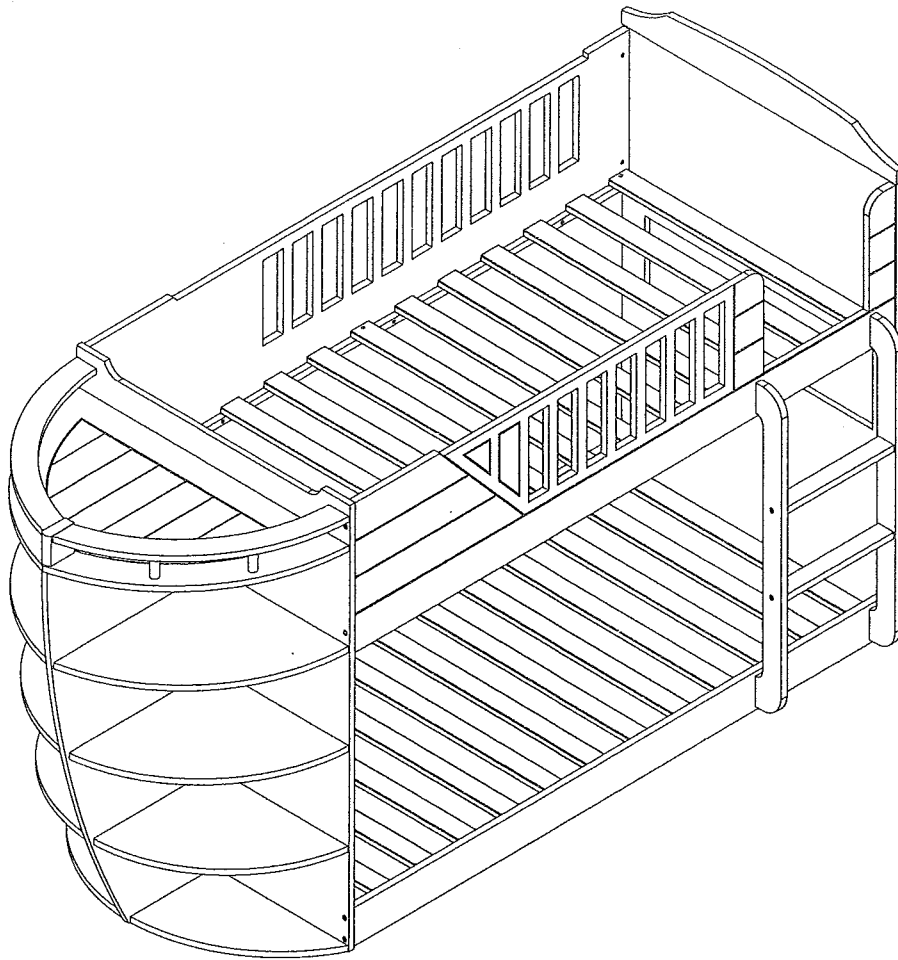





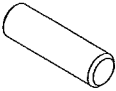
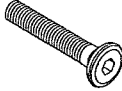
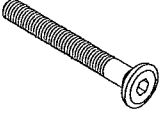

**READ THESE INSTRUCTIONS CAREFULLY  
BEFORE ATTEMPTING TO ASSEMBLE THIS BED.**

## **SAFETY WARNINGS AND GENERAL NOTES:**

- Follow the information on the warnings appearing on the upper bunk bed end structure and on the carton. Do not remove the warning label from the bed.
  - Always use the recommended size mattress or mattress support, or both, to help prevent the likelihood of entrapment or falls. (See Page 16)
  - The top surface of the mattress must be at least 5" below the upper edge of the guardrails. (See Page 16)
  - Do not allow children under 6 years of age to use the upper bunk.
  - Periodically check and ensure the guardrail, ladder and other components are in their proper position, free from damage, and all connectors are tight.
  - Prohibit horseplay on or under the bed. Always prohibit jumping on the bed.
  - Prohibit more than one person on upper bunk.
  - Always use the ladder for entering and leaving the upper bunk.
  - Do not use substitute parts. Contact the manufacturer or dealer for replacement parts.
  - Use of a night-light may provide added safety precaution for a child using the upper bunk.
  - Always use guardrails on both long sides of the upper bunk.
  - If the bunk bed will be placed next to a wall, the guardrail that runs the full length of the bed should be placed against the wall to prevent entrapment between the bed and the wall.
  - The use of water or sleep flotation mattresses is prohibited.
  - Keep these instructions for future reference.
  - We recommend assembling your bunk bed on the shipping carton to protect your floor or carpet. Be certain all staples are out of the box before beginning assembly on the shipping carton.
- STRANGULATION HAZARD** - Never attach or hang items to any part of the bunk bed that are not designed for use with the bed; for example, but not limited to, hooks, belts, and jump ropes.

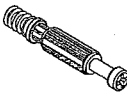
# HARDWARE LIST :

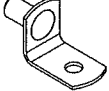
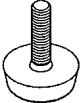
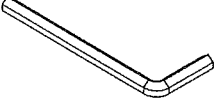
ITEM	QTY	DESCRIPTION	
A	54		PLASTIC DOWEL (M8 X 30MM)
B	28		PLASTIC DOWEL (M10 X 35MM)
C	4		JCBC BOLT (M6 X 35MM)
D	20		JCBC BOLT (M6 X 50MM)
E	20		JRN NUT (M6 X 13MM)
F	16		CSK C/B SCREW (M3.5 X 16MM)
G	12		CSK C/B SCREW (M4 X 32MM)
H	33		CONNECTING BOLT (34MM)
J	33		MINIFIX (12MM)
K	16		1225 SHELF SUPPORT
L	5		BASE GLIDE L190 (M6 x 23MM)
M	1		ALLEN KEY (M4 X 60MM)

- The assembly will require at least two people to complete.
- Make sure all the fasteners are tight.
- Due to the size of this bed, It must be assembled within the space it will occupy.
- Above all, take your time and read the instruction carefully.

**TOOLS REQUIRED :**  
Crosshead Screwdriver

**PARTS LIST :**

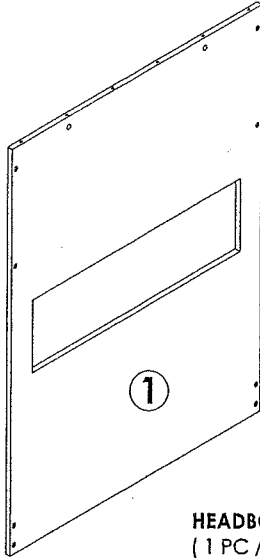

**HEADBOARD PANEL**  
( 1 PC / SET )  
CARTON 1 OF 4

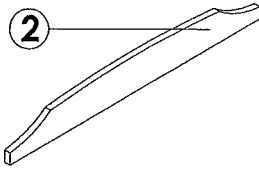

**HEADBOARD TOP RAIL**  
( 1 PC / SET )  
CARTON 2 OF 4

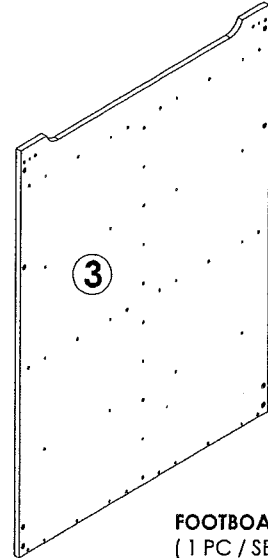

**FOOTBOARD PANEL**  
( 1 PC / SET )  
CARTON 1 OF 4

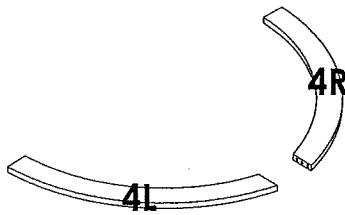

**FOOTBOARD TOP RAIL (L/R)**  
( 2 PCS / SET )  
CARTON 2 OF 4



**CORNER BLOCK**  
( 1 PC / SET )  
CARTON 3 OF 4

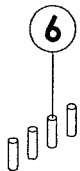

**ROUND STICK**  
( 4 PCS / SET )  
CARTON 3 OF 4

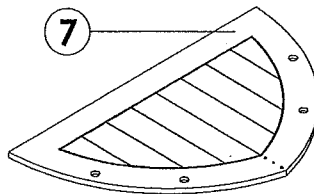

**TOP PANEL**  
( 1 PC / SET )  
CARTON 2 OF 4

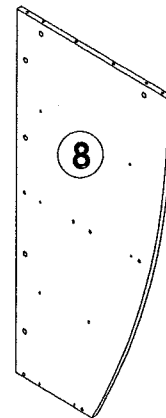

**CENTER PANEL**  
( 1 PC / SET )  
CARTON 1 OF 4

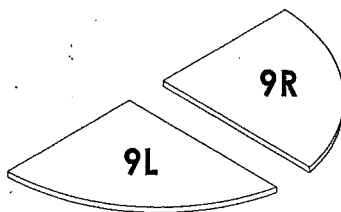

**TOP SHELVES (L/R)**  
( 2 PCS / SET )  
CARTON 2 OF 4

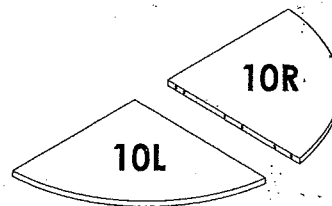

**2ND SHELVES (L/R)**  
( 2 PCS / SET )  
CARTON 2 OF 4

**PARTS LIST :**

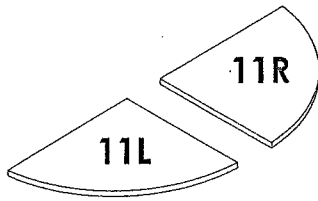

**3RD SHELVES (L/R)**  
( 2 PCS / SET )  
CARTON 2 OF 4

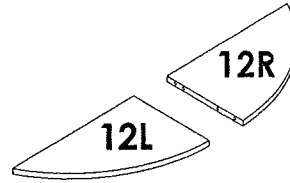

**BOTTOM SHELVES (L/R)**  
( 2 PCS / SET )  
CARTON 2 OF 4

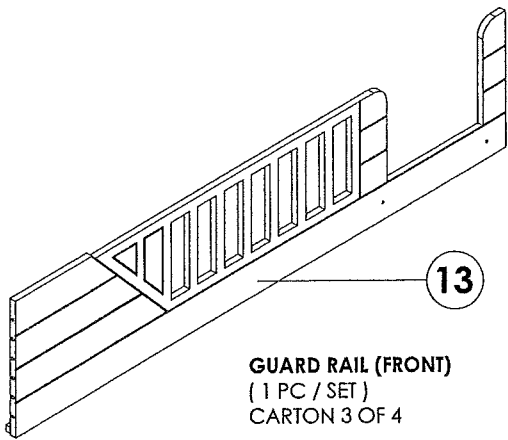

**GUARD RAIL (FRONT)**  
( 1 PC / SET )  
CARTON 3 OF 4

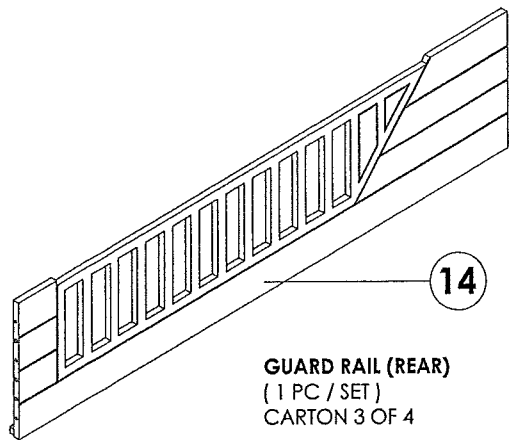

**GUARD RAIL (REAR)**  
( 1 PC / SET )  
CARTON 3 OF 4

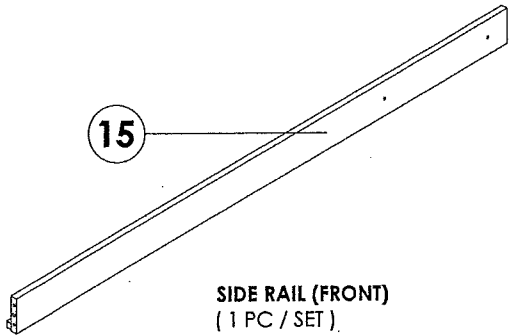

**SIDE RAIL (FRONT)**  
( 1 PC / SET )  
CARTON 3 OF 4

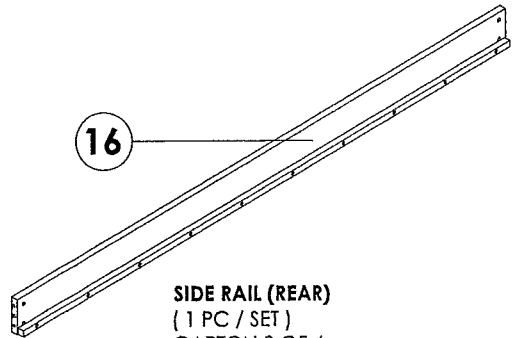

**SIDE RAIL (REAR)**  
( 1 PC / SET )  
CARTON 3 OF 4

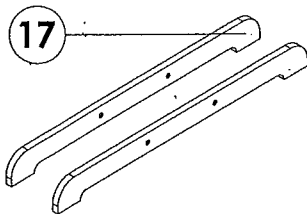

**LADDER POST**  
( 2 PCS / SET )  
CARTON 3 OF 4

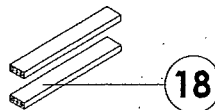

**LADDER SLAT**  
( 2 PCS / SET )  
CARTON 3 OF 4

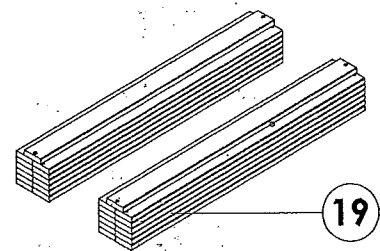

**SLAT**  
( 26 PCS / SET )  
CARTON 4 OF 4

# STEP 1

1. Insert the **Plastic Dowels (B)** into Ø10MM holes on **Guard Rails (Front) & (Rear), Side Rails (Front) & (Rear)** by using a Rubber Hammer as shown in **Figure 1**.

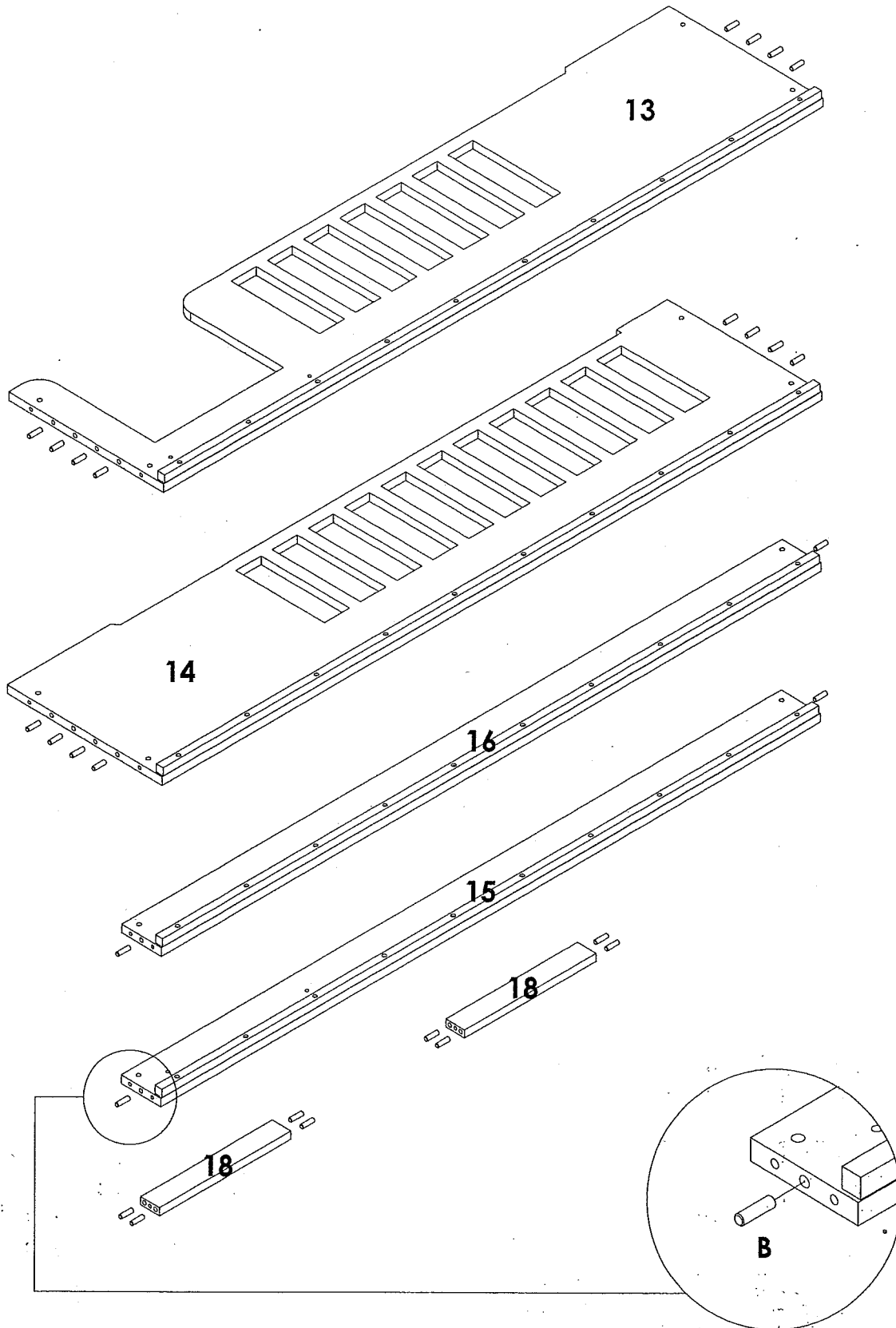



Figure 1

## HARDWARE USED IN THIS STEP

B	28		PLASTIC DOWEL (M10 X 35MM)
---	----	---	-------------------------------

# STEP 2

1. Insert the Plastic Dowels (A) into Ø10MM holes on Footboard Top Rail (L/R), Corner Block, Top Panel, Center Panel, 2nd Shelves, Bottom Shelves and Headboard Panel by using a Rubber Hammer as shown in Figure 2.

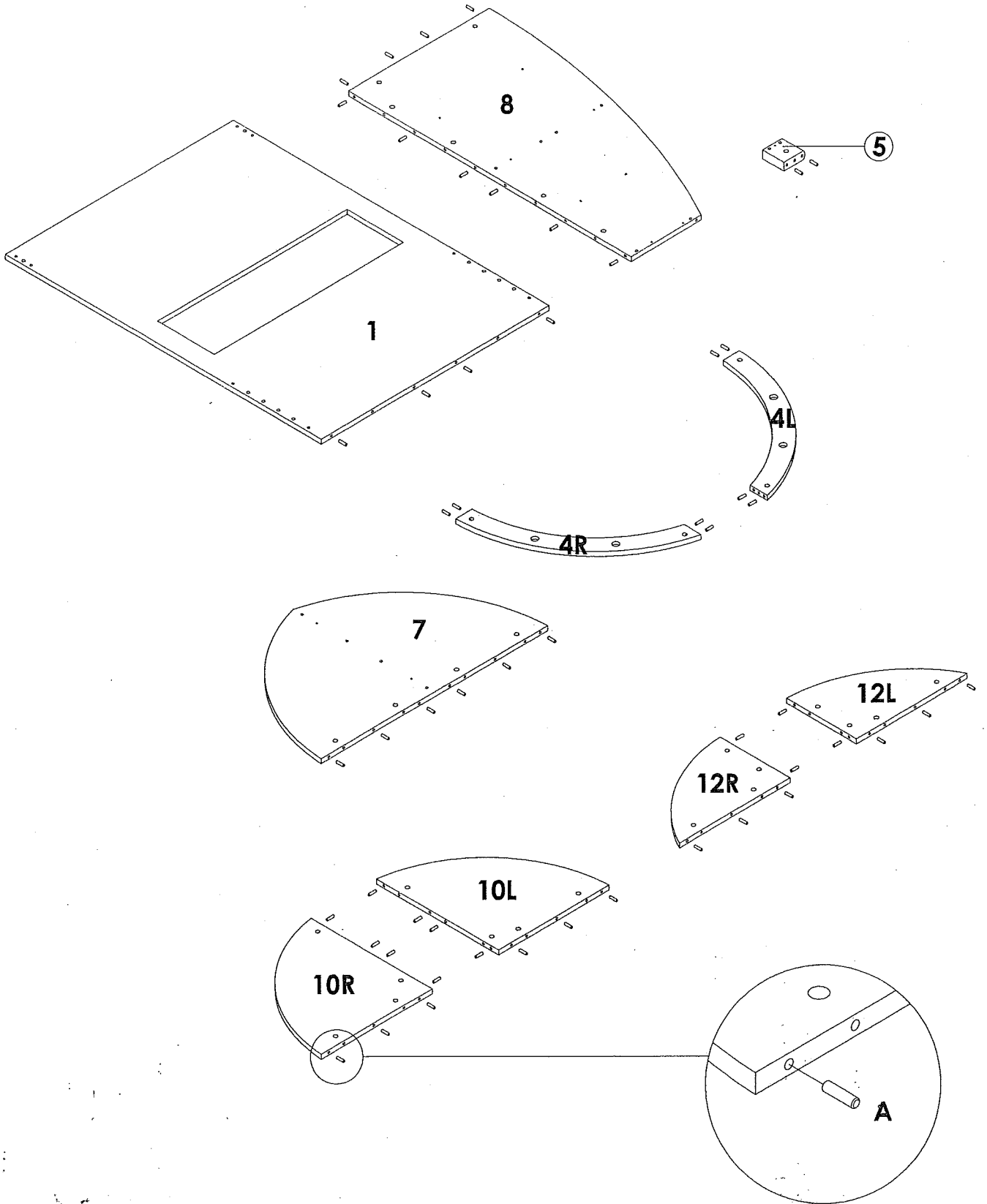



Figure 2

**HARDWARE USED IN THIS STEP**

A	54		PLASTIC DOWEL (M8 X 30MM)
---	----	---	------------------------------

# STEP 3

1. Attach **Connecting Bolts (H)** into specified Ø5MM holes on **Footboard Panel** by using a Crosshead Screw Driver as shown in **Figure 3**.

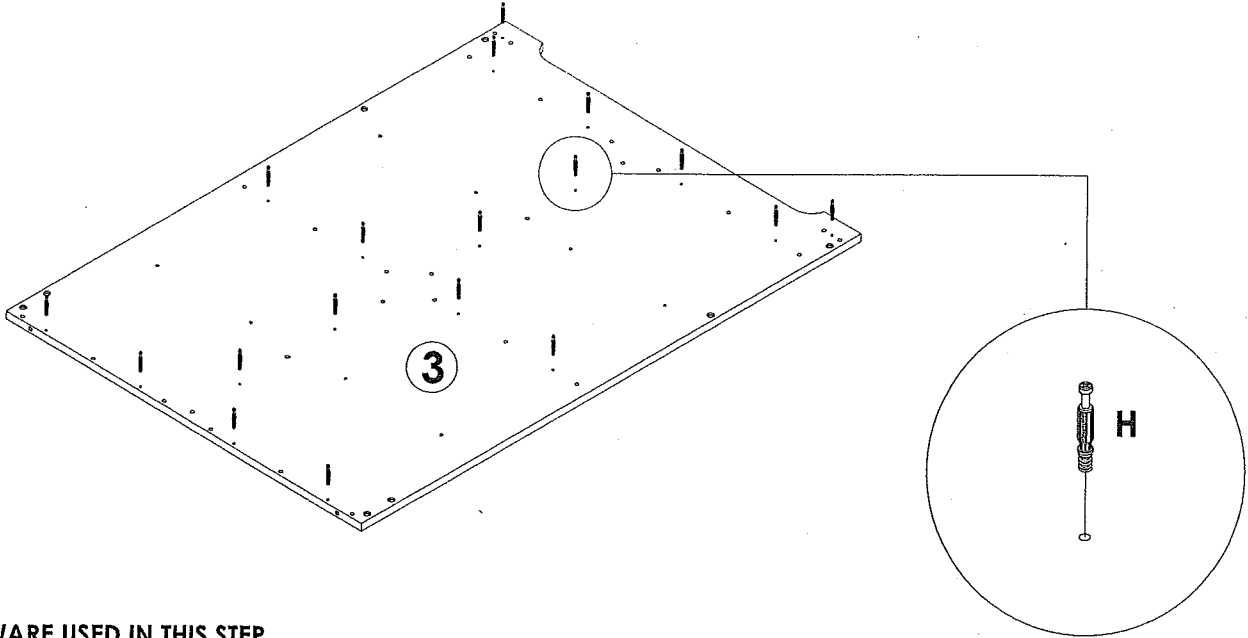

**HARDWARE USED IN THIS STEP**

H	18		<b>CONNECTING BOLT (34MM)</b>
---	----	--	-------------------------------

**Figure 3**

# STEP 4

1. Attach and secure **Footboard Top Rail** onto **Corner Block** by using **Connecting Bolts (H)** and **Minifix (J)** as shown in **Figure 4**, tighten **Minifix (J)** up by using a Crosshead Screw Driver.

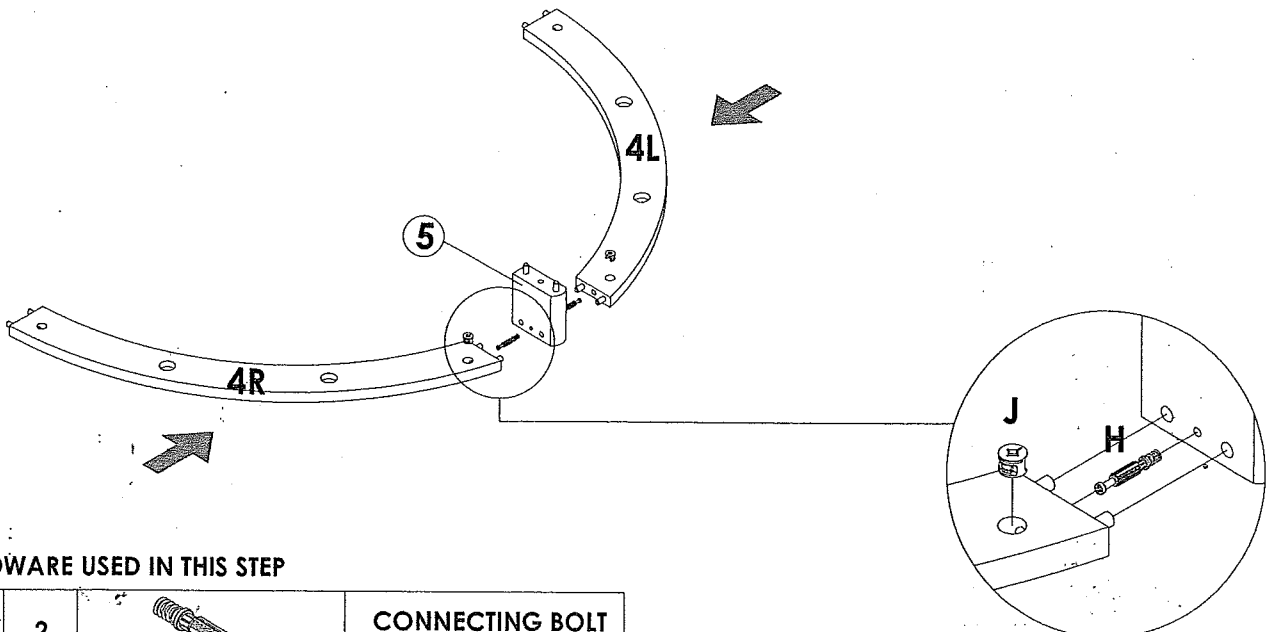

**HARDWARE USED IN THIS STEP**

H	2		<b>CONNECTING BOLT (34MM)</b>
J	2		<b>MINIFIX (12MM)</b>

**Figure 4**

# STEP 5

1. Attach **Round Sticks** into extruded holes on surface of **Top Panel**.

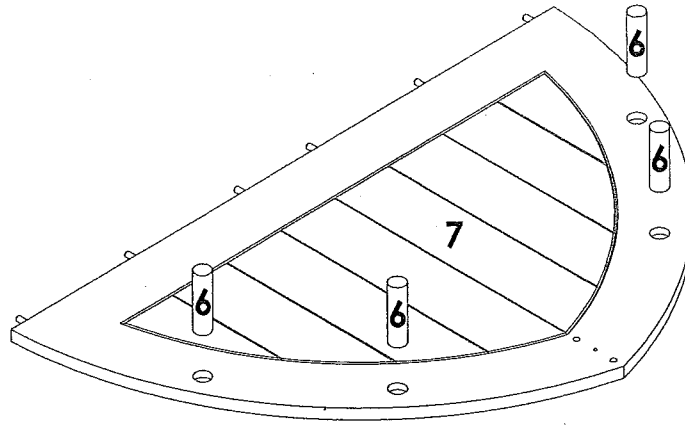

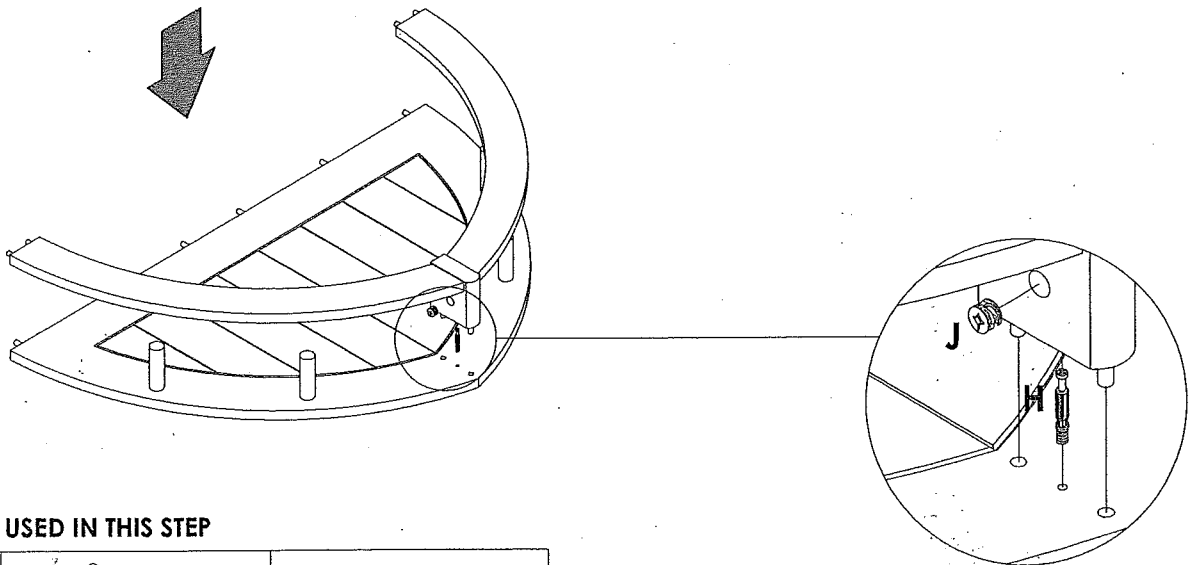

# STEP 6

1. Connect both **Corner Block** and **Top Panel** together by using **Connecting Bolts (H)** and **Minifix (J)** as shown in **Figure 5**, tighten **Minifix (J)** up by using a Crosshead Screw Driver.



**HARDWARE USED IN THIS STEP**

H	1		<b>CONNECTING BOLT (34MM)</b>
J	1		<b>MINIFIX (12MM)</b>

**Figure 5**



# STEP 7

1. Attach **Connecting Bolts (H)** into specified Ø5MM holes on another side of **Top Panel** by using a Crosshead Screw Driver as shown in **Figure 6**.

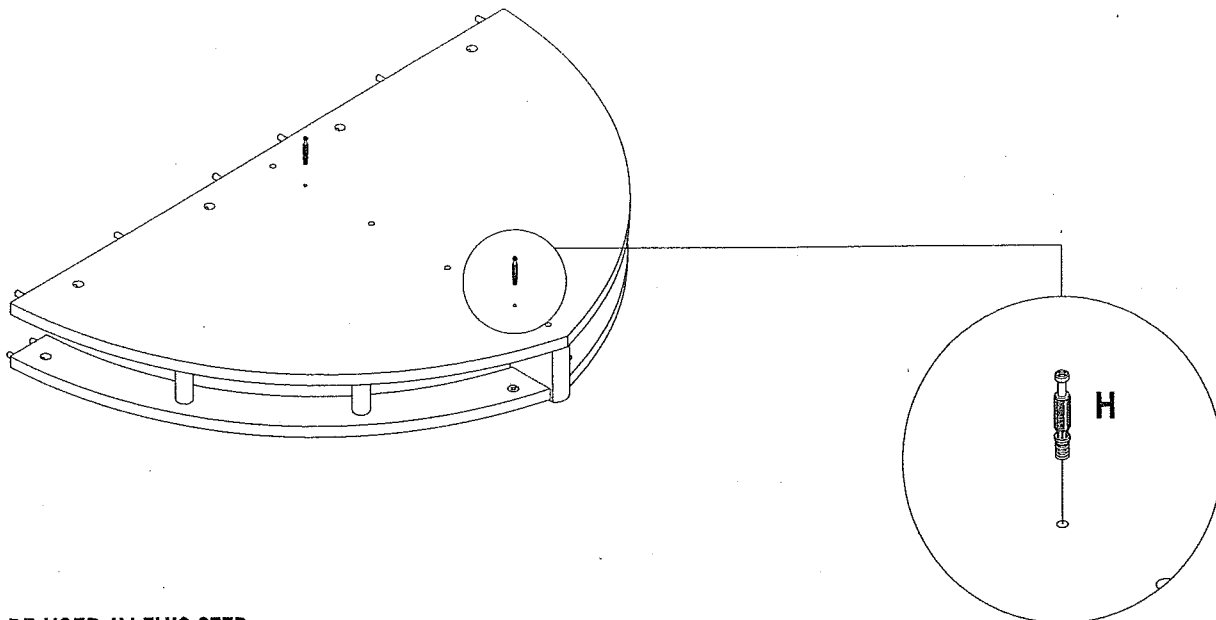

Figure 6

**HARDWARE USED IN THIS STEP**

H	2		<b>CONNECTING BOLT (34MM)</b>
---	---	--	-------------------------------

# STEP 8

1. Connect both **Center Panel** and **Top Panel** together by using **Minifix (J)** as shown in **Figure 7**; tighten it up by using a Crosshead Screw Driver.

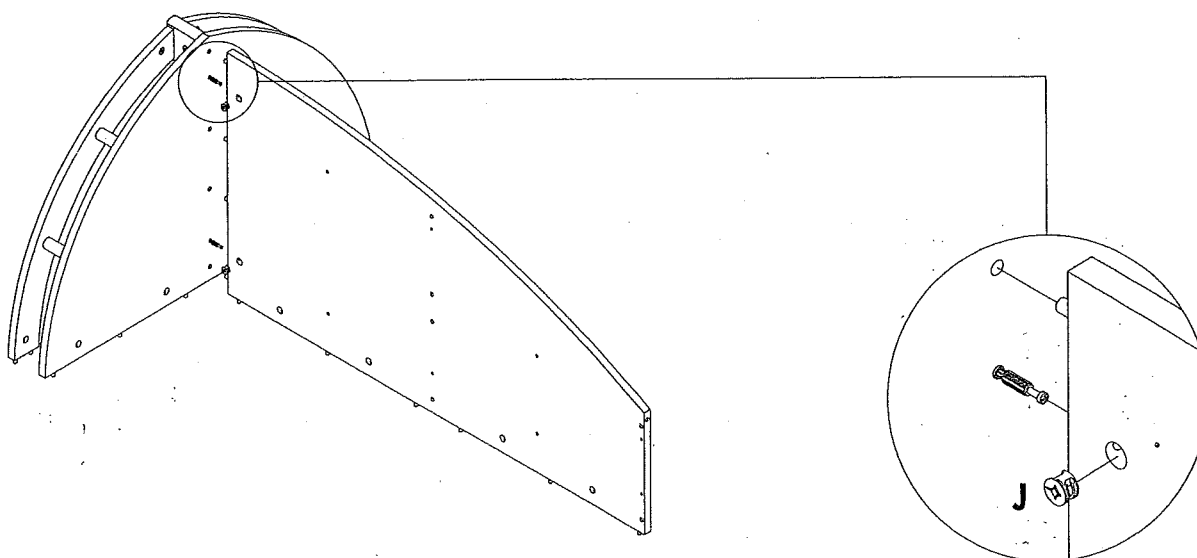

Figure 7

**HARDWARE USED IN THIS STEP**

J	2		<b>MINIFIX (12MM)</b>
---	---	--	-----------------------

# STEP 9

1. Attach **2nd Shelves (L/R) & Bottom Shelves (L/R)** on either side of **Center Panel** by using **Connecting Bolts (H)** and **Minifix (J)** as shown in **Figure 8**, tighten **Minifix (J)** up by using a Crosshead Screw Driver.

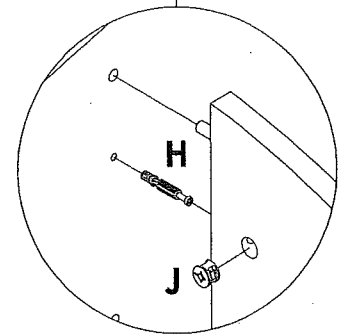
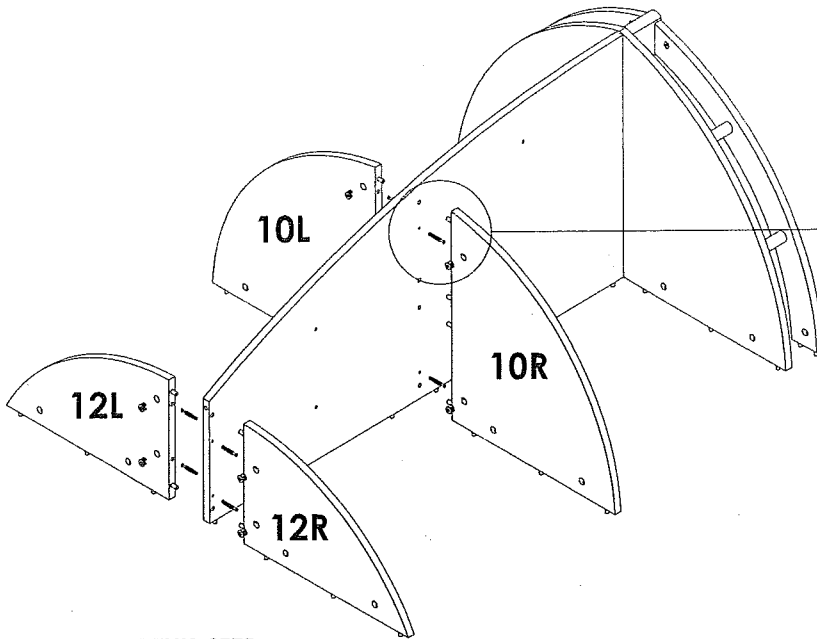

Figure 8

**HARDWARE USED IN THIS STEP**

H	8		CONNECTING BOLT (34MM)
J	8		MINIFIX (12MM)

# STEP 10

1. Attach previous assembly onto **Footboard Panel** by using **Minifix (J)** as shown on **Figure 9**, tighten it up by using a Crosshead Screw Driver.

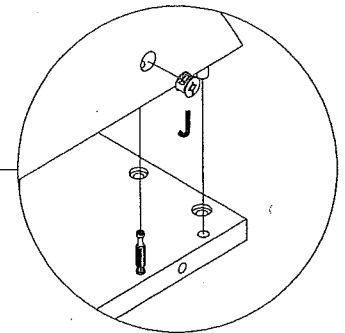
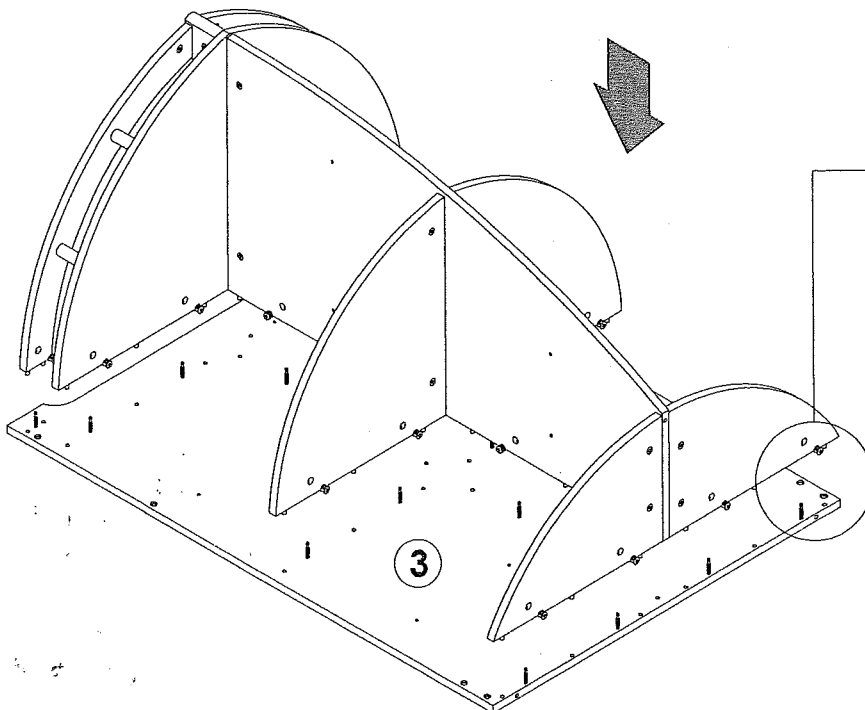

Figure 9

**HARDWARE USED IN THIS STEP**

J	18		MINIFIX (12MM)
---	----	--	-------------------

# STEP 11

1. Attach **Base Glide (L)** into specified holes at the foot of **Footboard Panel & Center Panel** as shown in **Figure 10**.

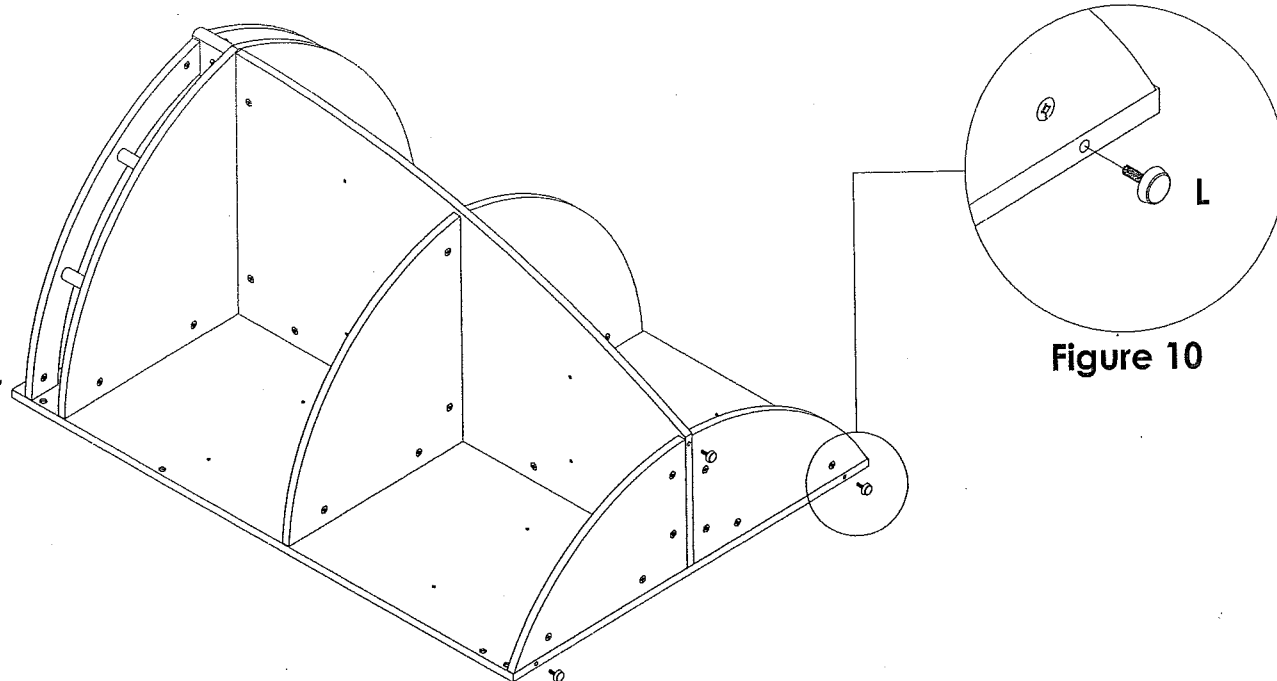

### HARDWARE USED IN THIS STEP

L	3		<b>BASE GLIDE L190 (M6 x 23MM)</b>
---	---	---	--

# STEP 12

1. Attach **Shelf Supports (K)** into specified  $\varnothing 6$ MM holes on **Center Panel** and **Footboard Panel** as shown in **Figure 11**.

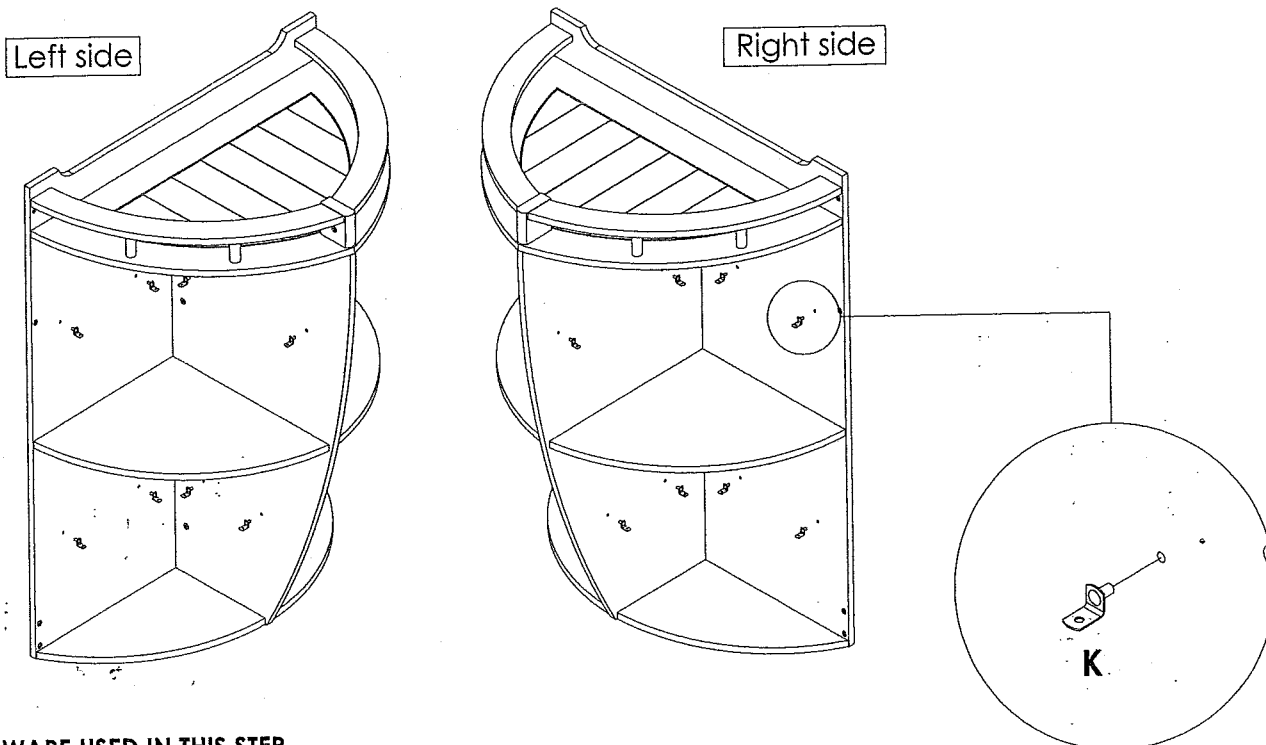

### HARDWARE USED IN THIS STEP

K	16		<b>1225 SHELF SUPPORT</b>
---	----	---	---------------------------

Figure 11

# STEP 13

1. Attach and secure **Top Shelves & 3rd Shelves** onto **Shelf Supports (K)** by using **CSK C/B screws (F)** as shown on **Figure 12**, tighten it up by using a Crosshead Screw Driver.

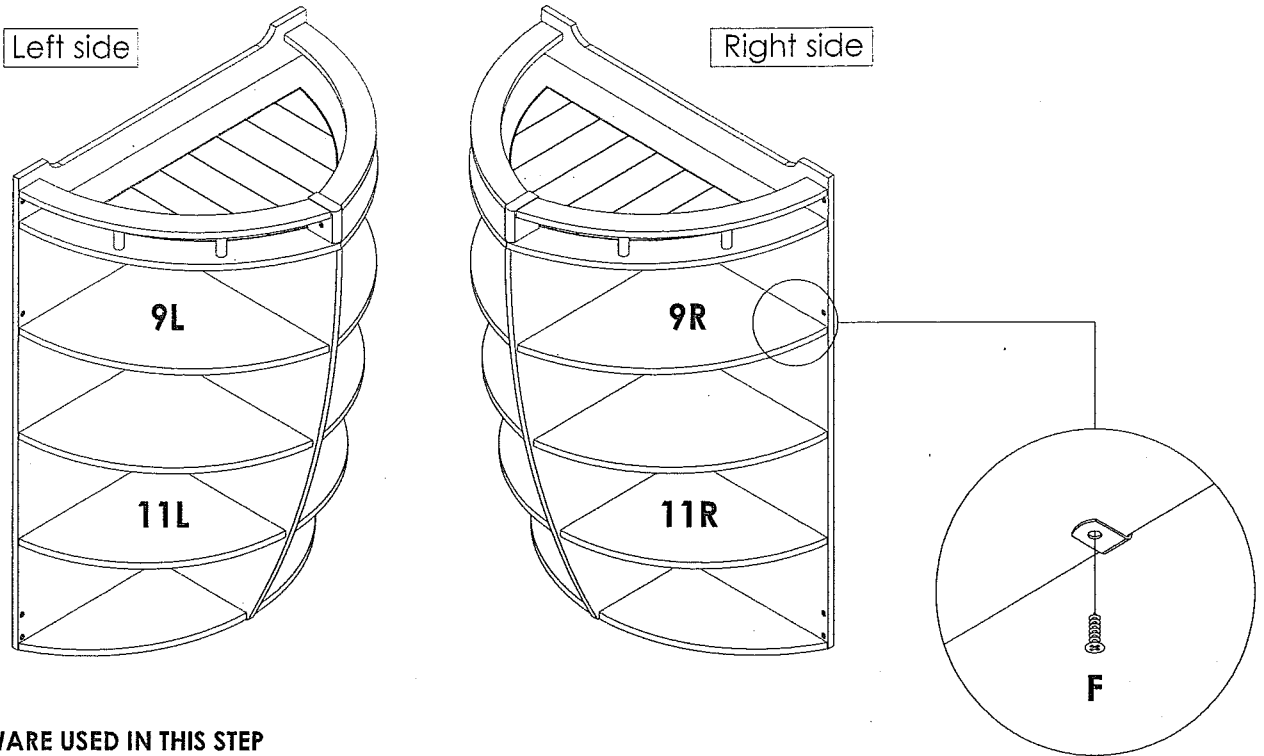



Figure 12

**HARDWARE USED IN THIS STEP**

F	16		CSK C/B SCREW (M3.5 x 16MM)
---	----	---	--------------------------------

# STEP 14

1. Attach and secure **Headboard Top Rail** onto **Headboard Panel** by using **Connecting Bolts (H)** and **Minifix (J)** as shown in **Figure 13**, tighten it up by using a Crosshead Screw Driver.  
 2. Attach **Base Glide (L)** into specified holes at the foot of **Headboard Panel** as shown in **Figure 14**.

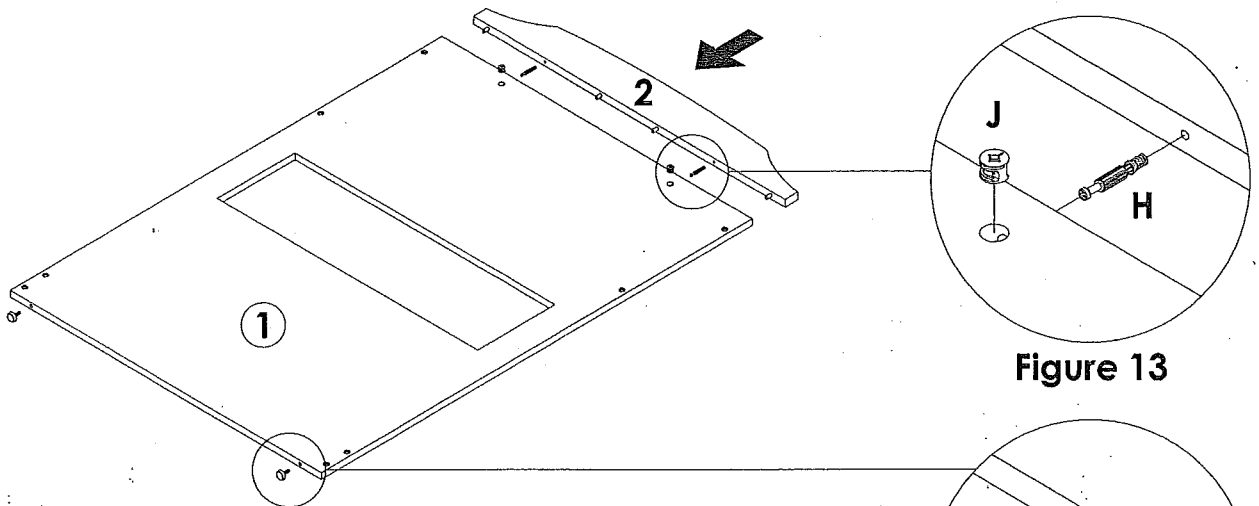

Figure 13

**HARDWARE USED IN THIS STEP**



H	2		CONNECTING BOLT (34MM)
J	2		MINIFIX (12MM)
L	2		BASE GLIDE L190 (M6 x 23MM)

Figure 14

# STEP 15

1. Insert **JRN Nuts (E)** into the holes found on both **Guard Rails & Side Rails** as shown in **Figure 15**.
2. Attach and secure both **Headboard** assemblies to the both **Guard Rails & Side Rails** by using **JCBC Bolts (D)**, tighten it up by using an **Allen Key (M)** as shown in **Figure 16**.

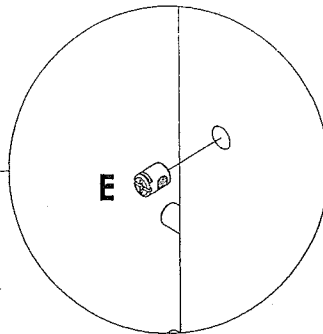

Figure 15

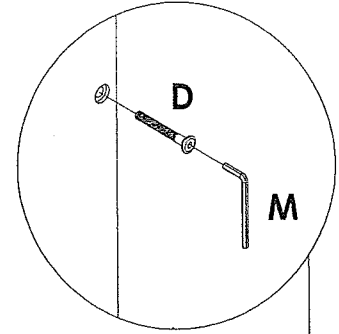
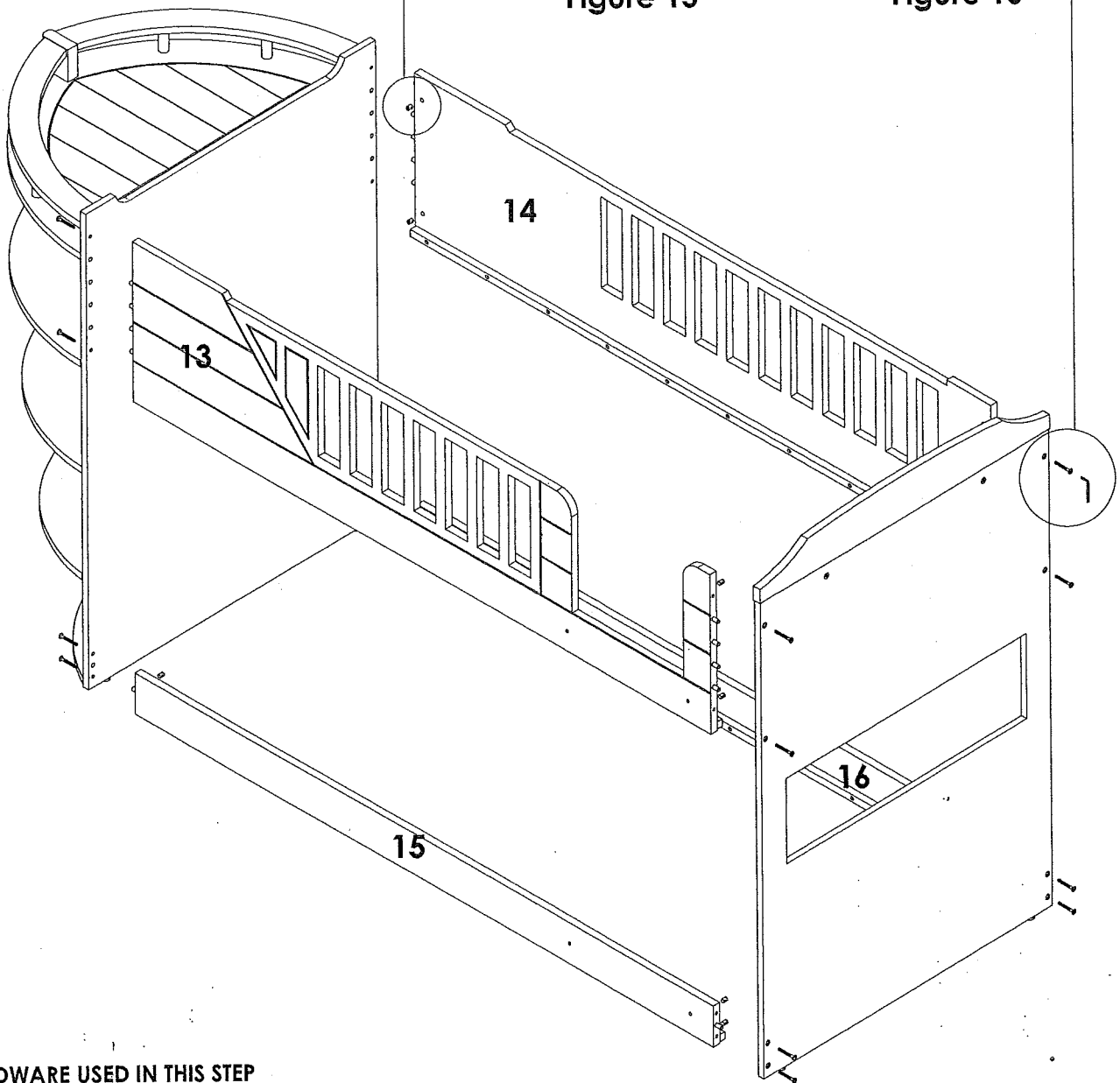

Figure 16



**HARDWARE USED IN THIS STEP**

D	16		JCBC BOLT (M6 x 50MM)
E	16		JRN NUT (M6 x 13MM)
M	1		ALLEN KEY (M4 x 60MM)

# STEP 16

1. Attach and secure both **Ladder Posts** onto **Ladder Slats** by using **JCBC Bolts (D)** and **JRN Nuts (E)** as shown on **Figure 17**, tighten it up by using an **Allen Key (M)**.

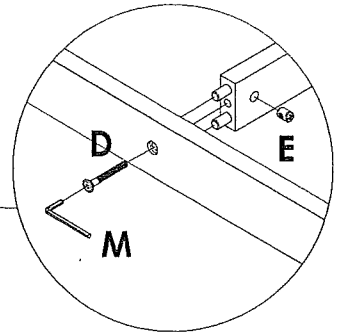
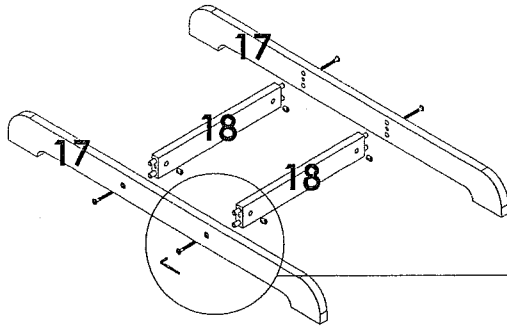





Figure 17

**HARDWARE USED IN THIS STEP**

D	4		JCBC BOLT (M6 x 50MM)
E	4		JRN NUT (M6 x 13MM)
M	1		ALLEN KEY (M4 x 60MM)

# STEP 17

1. Attach and secure **Ladder** onto **Guard Rail (Front)** and **Side Rail (Front)** by screwing in **JCBC Bolts (C)** in from behind as shown in **Figure 18**, tighten it up by using an **Allen Key (M)**.

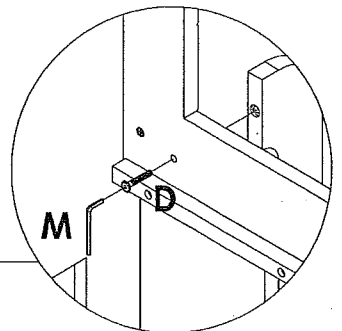
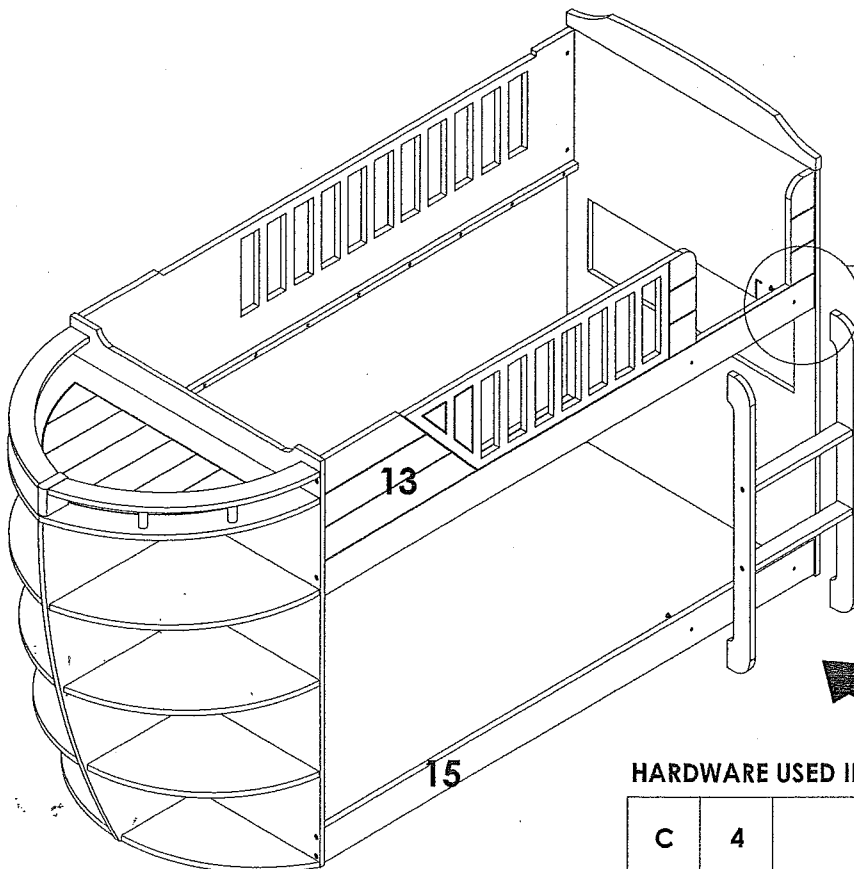
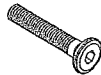



Figure 18

**HARDWARE USED IN THIS STEP**

C	4		JCBC BOLT (M6 x 35MM)
M	1		ALLEN KEY (M4 x 60MM)

# STEP 18

1. Attach and secure **Slats** onto **Guard Rails** and **Side Rails** by screwing in **CSK C/B Screw (G)** into specified pre-drilled holes on **Slats** as shown in **Figure 19**, tighten it up by using a Crosshead Screw Driver.
2. Go on to complete the entire **assembly**.

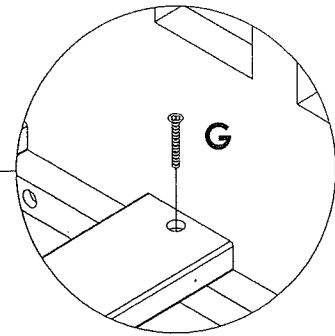
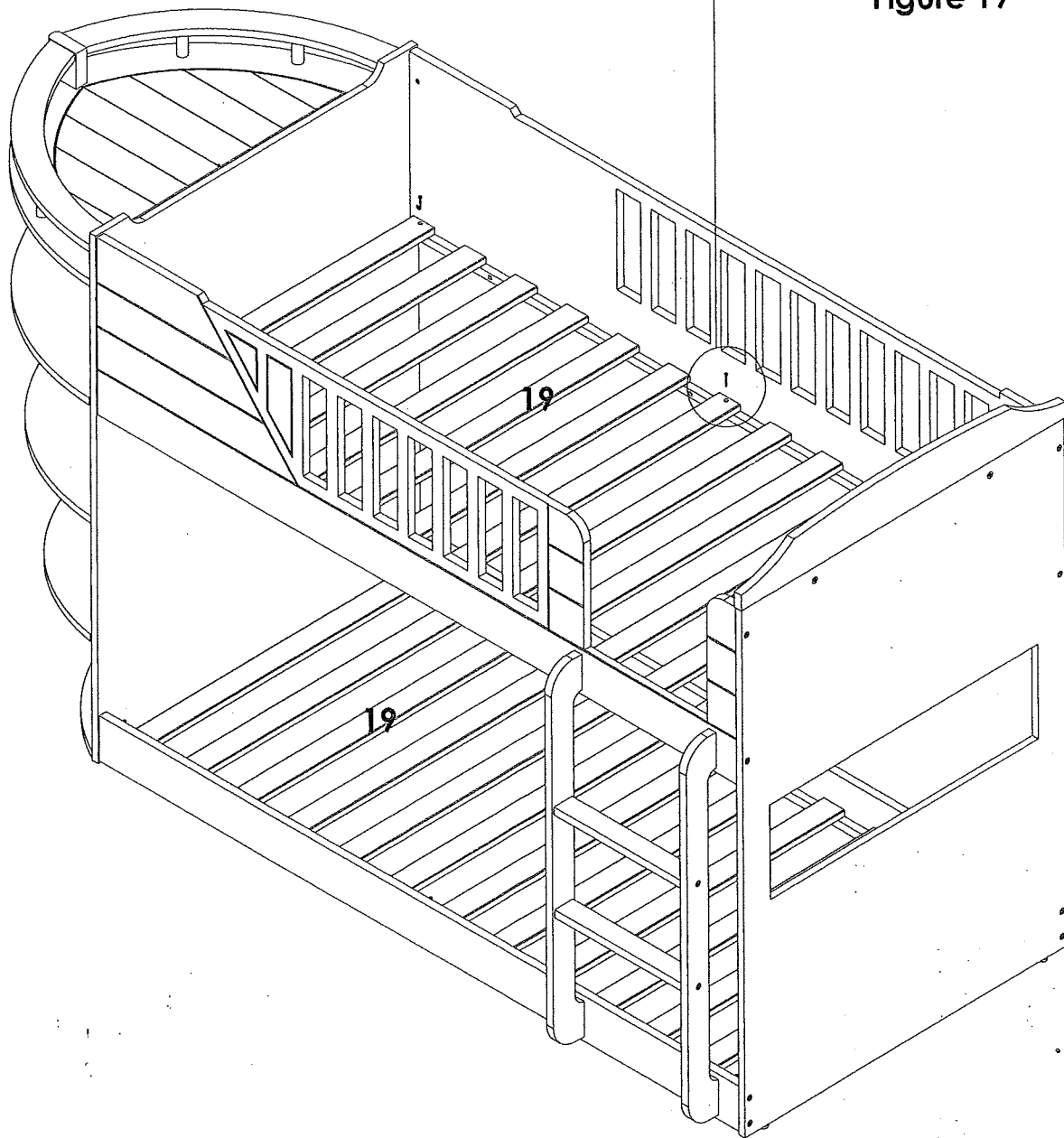



Figure 19



### HARDWARE USED IN THIS STEP

<b>G</b>	<b>12</b>		<b>CSK C/B SCREW (M4 x 32MM)</b>
----------	-----------	---	--------------------------------------

# BEDDING SPECIFICATION

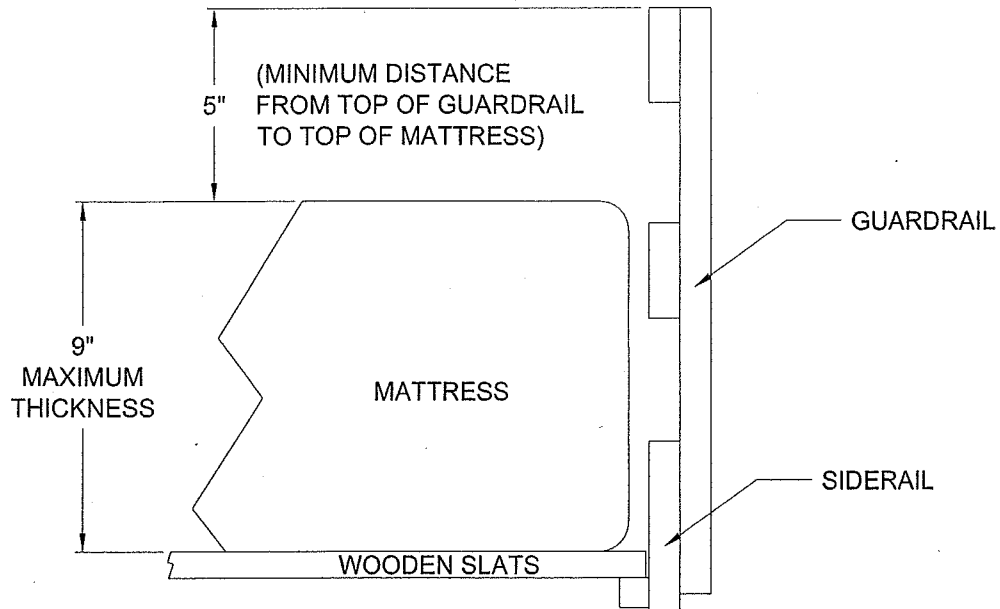

## MATTRESS SIZE

### Upper Bunk Mattress Specification :

- Only use a mattress that is 74" - 75" long and 37 1/2" - 38 1/2" wide on upper bunk.
- Ensure thickness of mattress does not exceed 9".

### Lower Bunk Mattress Specification :

- Only use a mattress that is 75" long and 39" wide on lower bunk.
- Ensure thickness of mattress is 9" only.

### Replacement parts :

Replacement parts, including additional guard rails, can be obtained from any ACME Furniture distributor or retailer.