

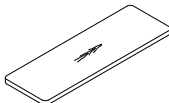







ASSEMBLY INSTRUCTION FOR ACME FURNITURE





MODEL# 82863 Sofa Table

Thank you for purchasing this quality product. Be sure to check all packing materials carefully for small parts which may have come loose inside the carton during shipment. Separate, identify, and count all parts and metal hardware. Compare with parts list to be sure all parts are present. If any part(s) are missing or damaged, please contact your local furniture dealer. For efficient and speedy service, please indicate the model number and code letter of the part(s) needed.

*** Do not fully tighten screws until fully assembled ***

COMPONENT PARTS		
DECERPTION	PART NAME	Q'TY(PCS)
①	Top Panel 	1pc
②	Shelf 	1pc
③	Left Big Wheel 	1pc
④	Right Big Wheel 	1pc
⑤	Left Small Wheel 	1pc
⑥	Right Small Wheel 	1pc
⑦	Small Wheel Support Tube 	2pcs
⑧	Big Wheel Support Tube 	2pcs
⑨	Side Connect Tube 	1pc

HARDWARE REQUIRED:

Ⓐ 	Bolt 1/4"x5/8" - 6pcs
Ⓑ 	Bolt 1/4"x1-3/8" - 12pcs
Ⓒ 	Allen Wrench M4 - 1pc
Ⓓ 	Bolt 1/4"x1-3/8" - 2pcs
Ⓔ 	Socket Wrench - 1pc

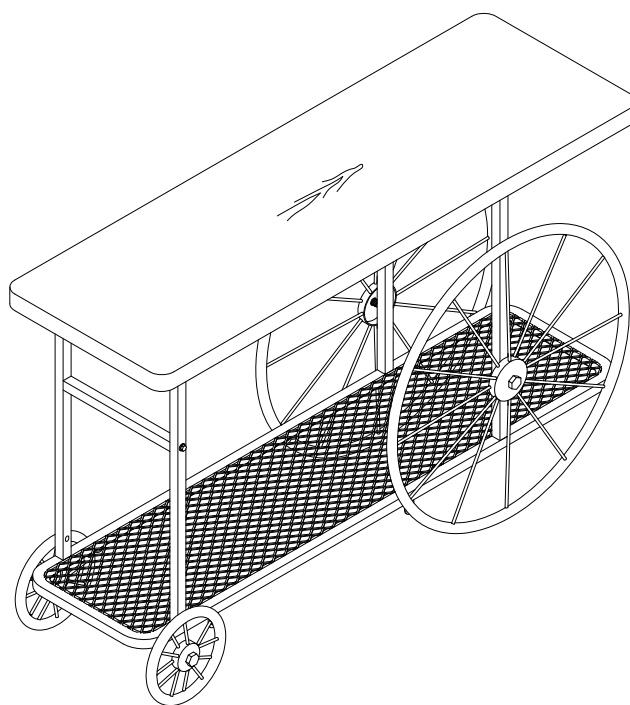

Attention:

***Mattresses not included.

***Some number parts listed on the instruction sheet may not be in parts bag as they may already be assemble.
Carefully check parts and packing materials prior to ordering replacements.

How to Assemble:

STEP 1.

Exploded View

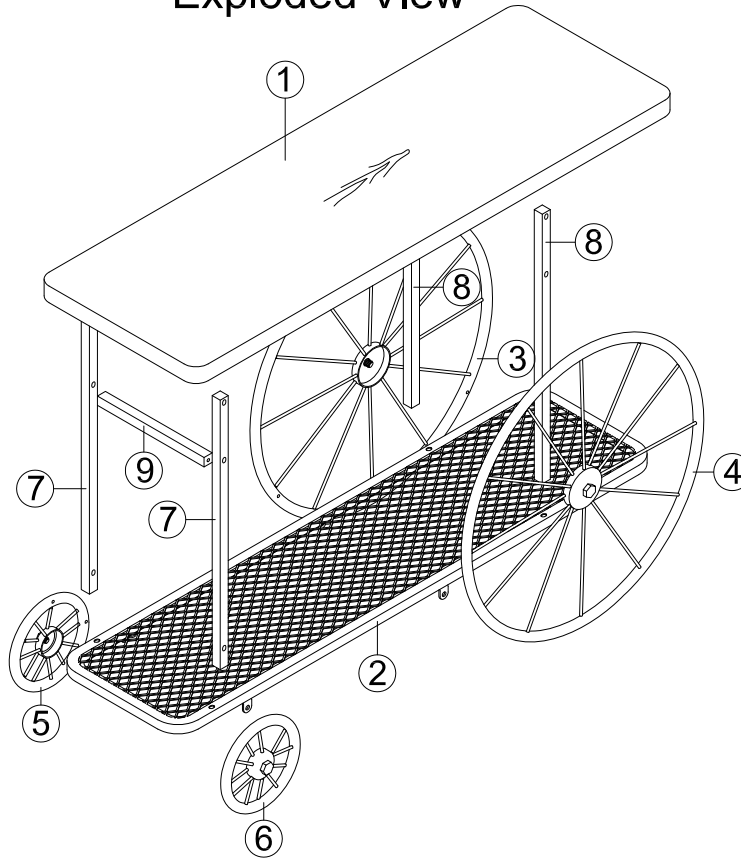

STEP 2.

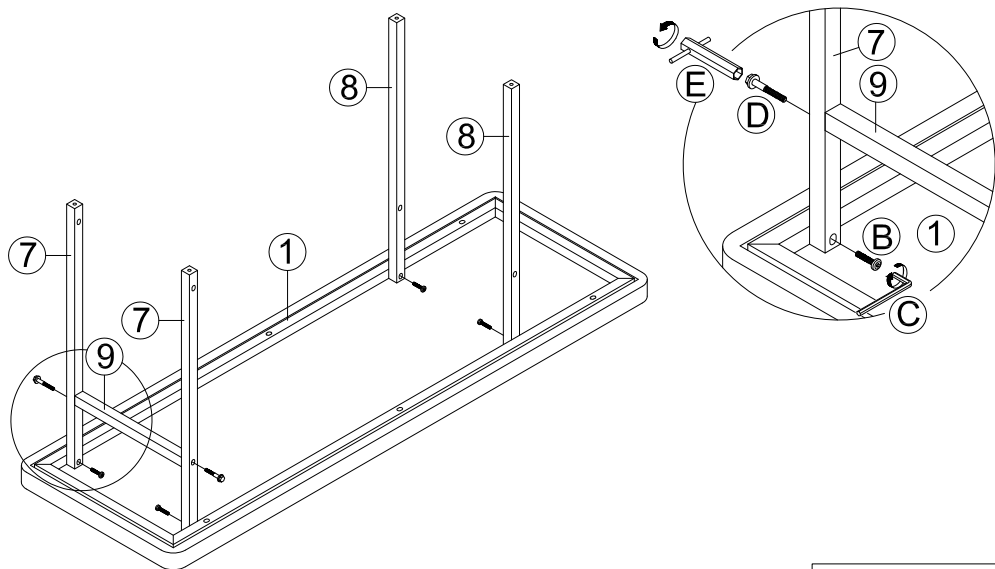

(B)		4pcs
(D)		2pcs

How to Assemble:

STEP 3.

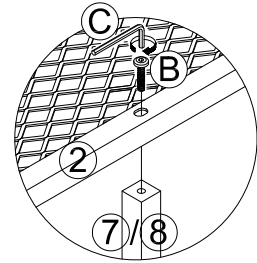
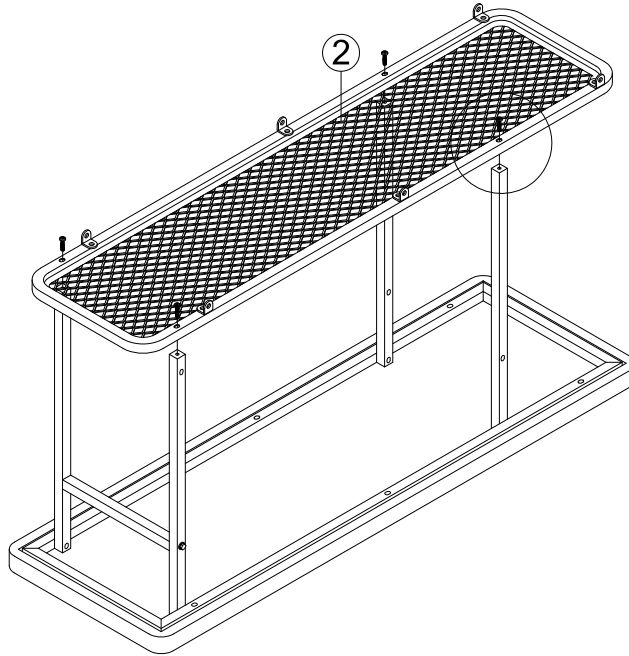

(B)  4pcs

STEP 4.

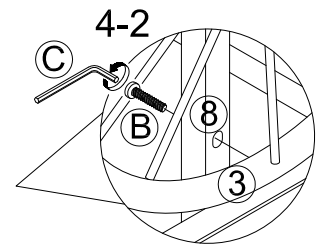
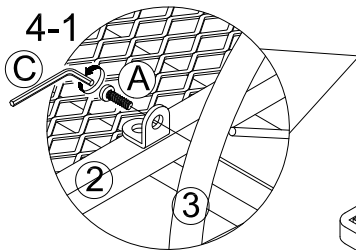
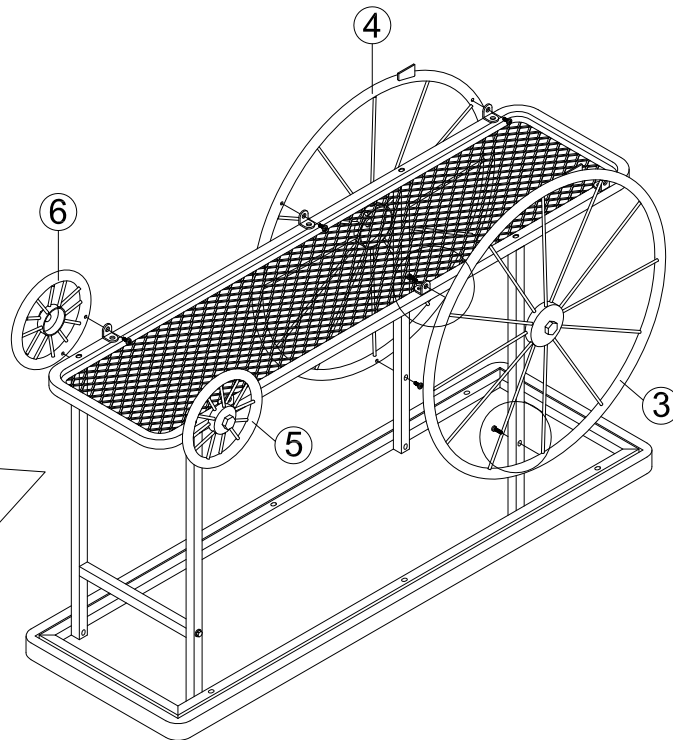

(A)  6pcs

(B)  4pcs