

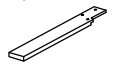





ASSEMBLY INSTRUCTIONS

**MODEL : 0116B
QUEEN BED**





**(Box 1)
BOX OF HEADBOARD & HB LEG**

No	ITEM	Qty
A	Headboard 	1 pc
B	Headboard Leg (L/R) (500mm) 	2 pcs



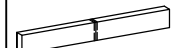

**(Box 1)
BOX OF HEADBOARD & HB LEG**

No	ITEM	Qty
1	JCBC Bolt M6 x 30mm 	6 pcs
2	Spring Washer 1/4" Rbw 	6 pcs
3	Flat Washer 1/4" ID x 13mmOD Blk 	6 pcs
4	Allen Key M6 x 65mm 	1 pc
5	12V+12W+1A Adaptor 	1 pc

**(Box 2)
BOX OF SIDE RAIL**

No	ITEM	Qty
C	Bed Slat 	4 pc
D	Bed Slat Support with leveler 	4 pcs
E	Side Rail 	2 pcs
F	Footboard Leg 	2 pcs
G	Footboard 	1 pc

**(Box 2)
BOX OF SIDE RAIL**

No	ITEM	Qty
5	JCBC Bolt M6 x 40mm 	6 pcs
6	Allen Key M4 x 65mm 	1 pc
7	Allen Key M5 x 65mm 	1 pc
8	Flat Head Chipboard Screw M4 x 32mm 	8 pcs
9	Flat Head Chipboard Screw M4 x 50mm 	4 pcs

STEP 1

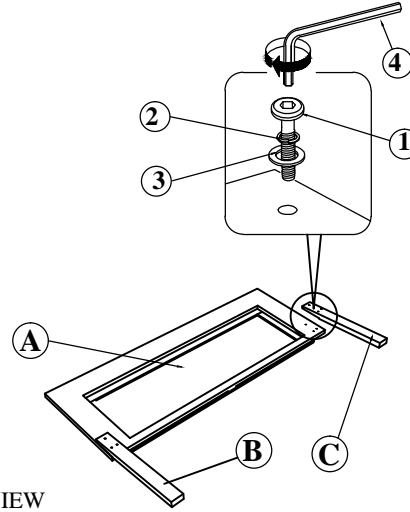

**BACK VIEW

**Please take note the marking on the leg **

STEP 2

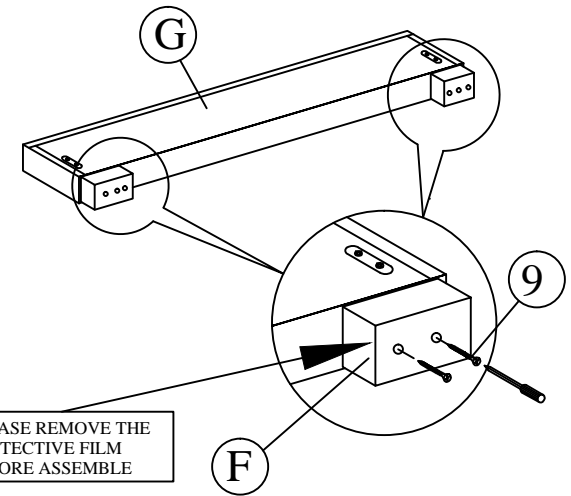

PLEASE REMOVE THE
PROTECTIVE FILM
BEFORE ASSEMBLE

STEP 3

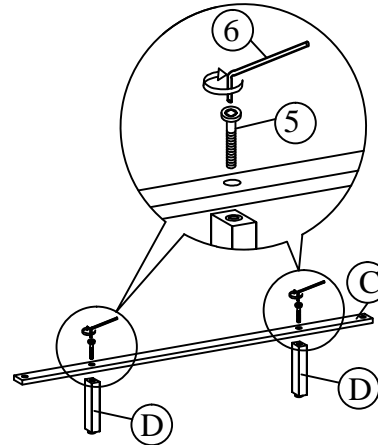

STEP 4

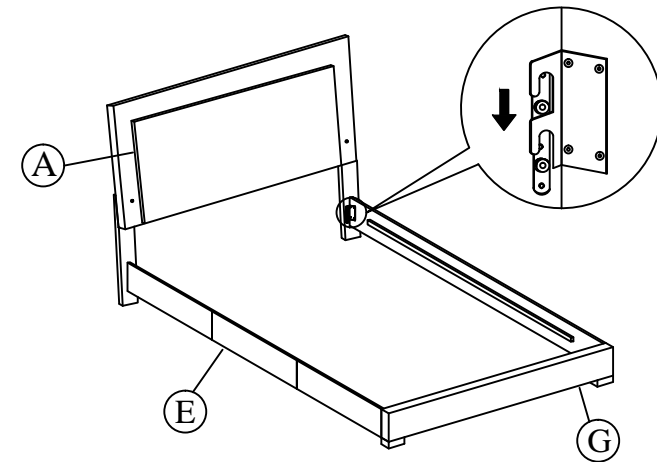

STEP 5

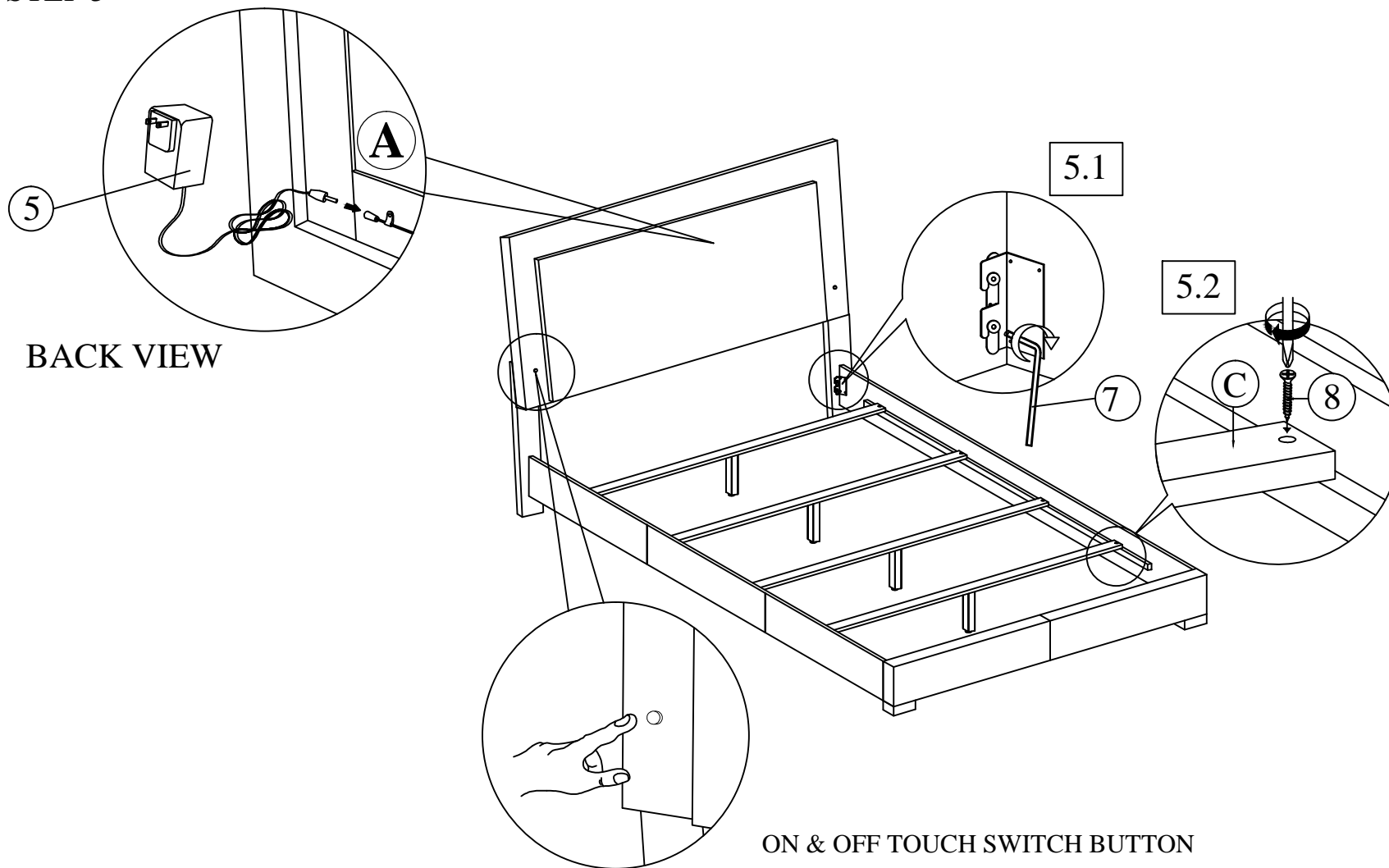

NOTE : MUST TIGHTEN SCREWS PERIODCALLY WITH USE SCREW WILL BECOME LOOSE CHECK TIGHTNESS OF ALL SCREW EVERY 6-8 WEEKS.