

ASSEMBLY INSTRUCTION FOR ACME FURNITURE











MODEL#92259

Thank you for purchasing this quality product .Be sure to check all packing material carefully for small parts which may have come loose inside the carton during shipment.Separate,identify and count all parts and metal hardware.Compare with list to be sure all parts are present.If any part(s) are missing or damaged ,please contact your local furniture dealer.For efficient and speedy service,please indicate the model number and code letter of part(s) needed.

*****Do not fully tighten screws until fully assembled*****

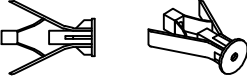
COMPONENT PARTS

HARDWARE REQUIRED

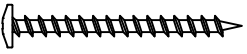
NO.	DESCRIPTION	QUANTITY	NO.	DESCRIPTION	QUANTITY	SIZE
A	LEFT SIDE FRAME	1PC	1	CAM BOLT 	24PCS	Ø6* 35mm
B	RIGHT SIDE FRAME	1PC	2	CAM LOCK 	24PCS	Ø15*12mm
C	TOP BOARD	1PC				
D	SHELF	4PCS	3	SHORT BOLT 	36PCS	D11*Ø1/4**35mm
E	BOTTOM PANEL	1PC	4	SPRING WASHER 	36PCS	D11*Ø1/4**1mm
			5	FLAT WASHER 	36PCS	D19*Ø1/4**1.2mm
			6	ALLEN KEY 	1PC	Ø4*57mm
			7	PLUG 	1PC	30mm
			8	TIGHTWIRE 	1PCS	L265mm
			9	BRACKET 	2PCS	26 X 13mm
			10	SHORT SCREWS 	1PC	M4 X 3/4*mm
			11	LONG SCREWS 	1PC	M4 X 1-1/2*mm

Attention:

***Mattresses not included.

***Some number parts listed on the instruction sheet may not be in parts bag as they may already be assembled.Carefully check parts and packing materials prior to ordering replacements.

STEP 1:

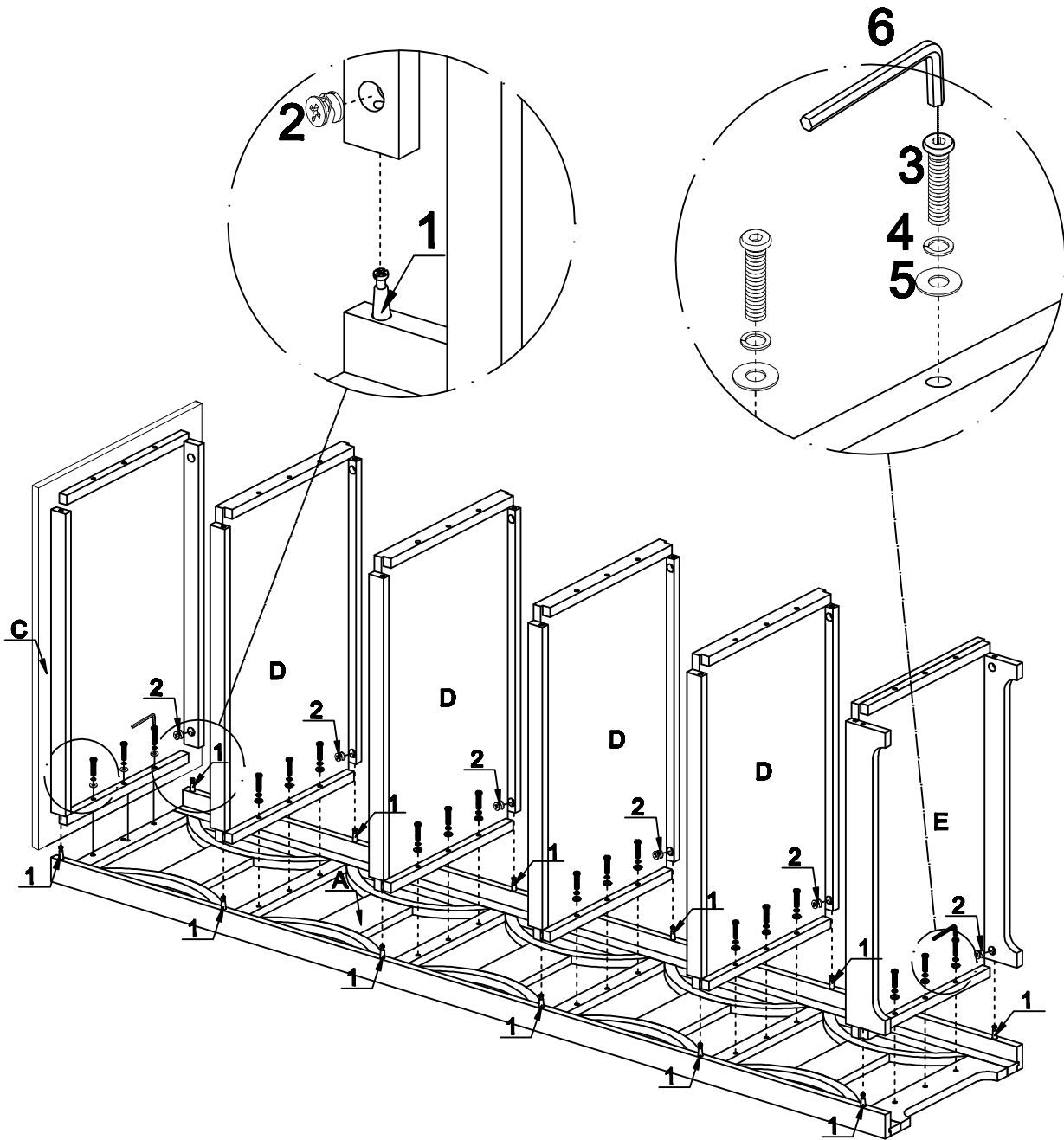

STEP 2:

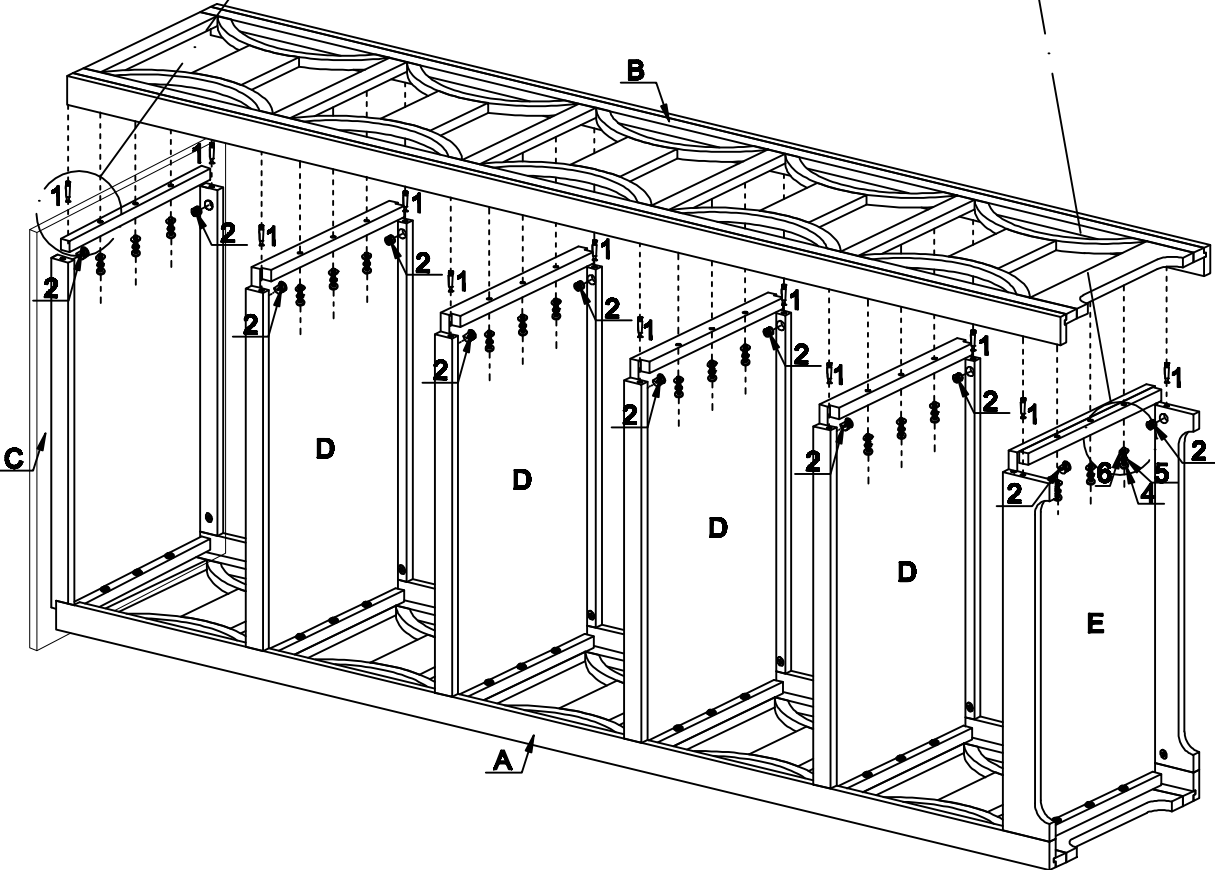
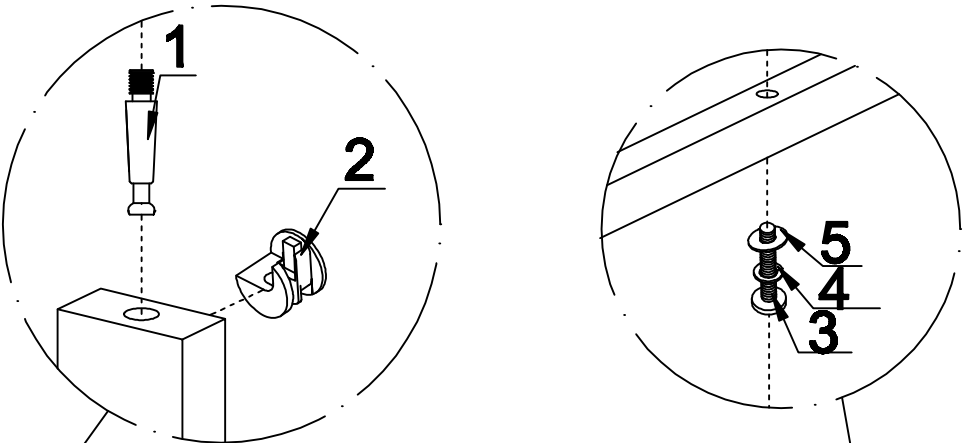

STEP 3:

