









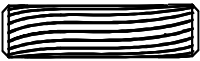

ASSEMBLY INSTRUCTION FOR ACME FURNITURE

MODEL#92257

Thank you for purchasing this quality product .Be sure to check all packing material carefully for small parts which may have come loose inside the carton during shipment. Separate, identify and count all parts and metal hardware. Compare with list to be sure all parts are present. If any part(s) are missing or damaged ,please contact your local furniture dealer. For efficient and speedy service, please indicate the model number and code letter of part(s) needed.

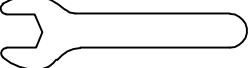
*****Do not fully tighten screws until fully assembled*****

COMPONENT PARTS HARDWARE REQUIRED

NO.	DESCRIPTION	QUANTITY	NO.	DESCRIPTION	QUANTITY	SIZE
A	TABLE TOP	1PC	1	WOOD PLUG 	4PCS	Ø8 X 30mm
B	SIDE FRAME	2PCS	2	SCREWS FOR HANDLE 	3PCS	D9*Ø5/32**35mm
C	LONG STRETCHER	1PC	3	ROUND HANDLE 	3PCS	
			4	FLAT WASHER 	2PCS	D19*Ø5/16**1.2mm
			5	FULL THREAD SCREW 	2PCS	63*Ø5/16**mm
			6	SHORT BOLT 	10PCS	D11*Ø1/4**2**mm
			7	HEX NUT 	2PCS	D12*Ø5/16**10
			8	WRENCH 	1PC	87*12mm
			9	ALLEN KEY 	1PC	57*Ø4
			10	SPRING WASHER 	10PCS	D11*Ø1/4**1mm
			11	FLAT WASHER 	10PCS	D19*Ø1-1/4**1.2mm
			12	CRESCENT GASKET 	2PCS	30*20*9*Ø5/16*

Attention:

***Mattresses not included.

***Some number parts listed on the instruction sheet may not be in parts bag as they may already be assembled. Carefully check parts and packing materials prior to ordering replacements.

STEP 1:

As shown in the picture,put crescent gasket 12 into the round holes of long stretcher C,use two wood plugs 5 and a full thread screw to joint side frame B and long stretcher C,ahd fix with flat washer 4 and hex nut 7,then use wrench 8 to lock them.

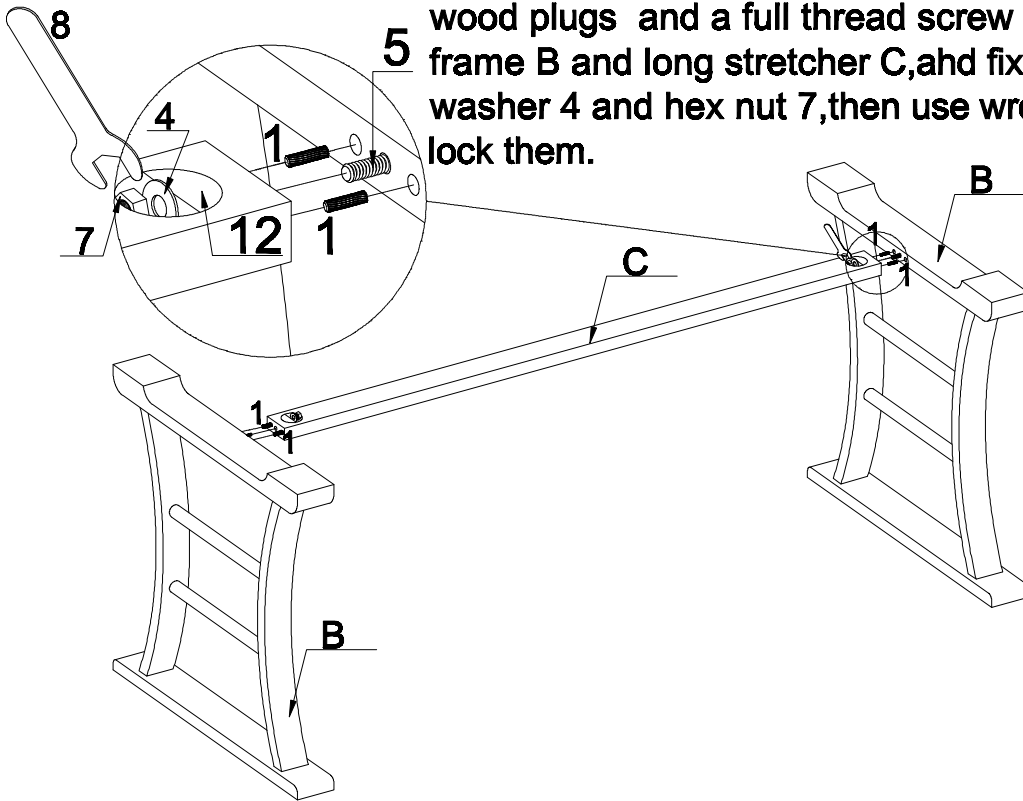

STEP 2: As shown in the picture,stand table top A upside down,and use short bolt 6,spring washer 10, flat washer 11 to fix table top A with side frame B, then use allen key 9 to lock them.

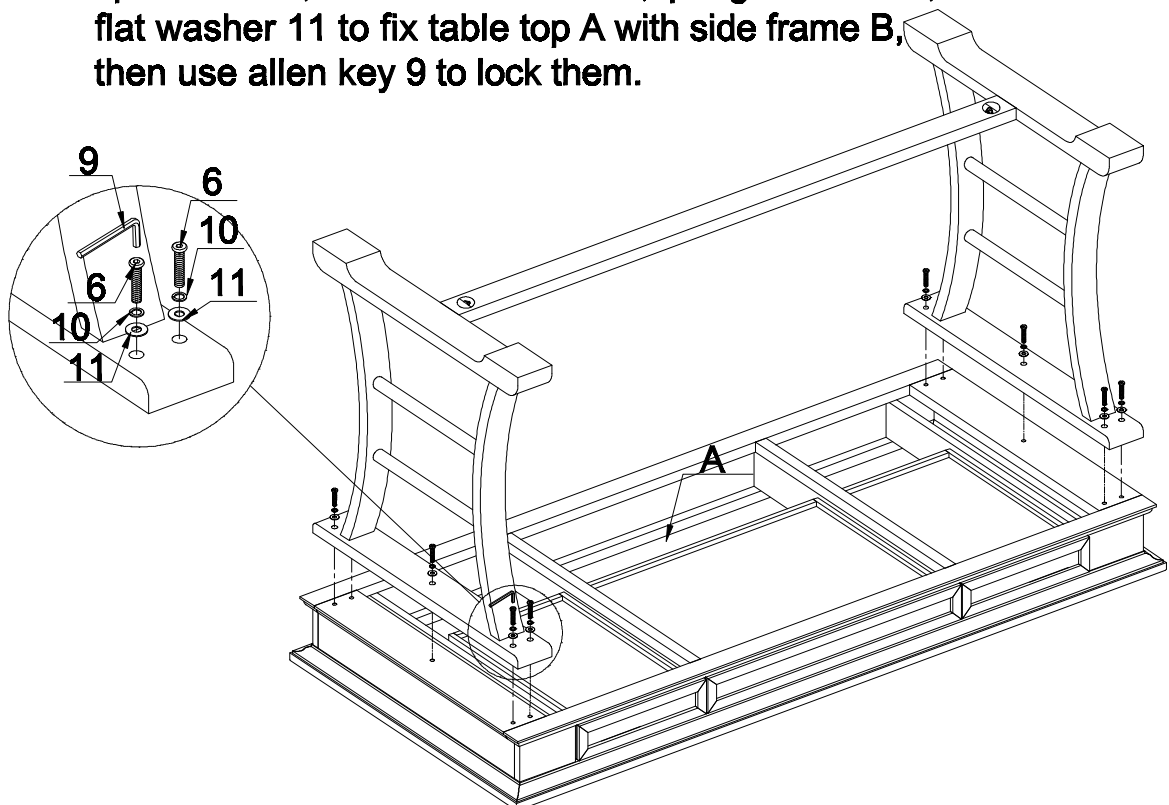

STEP 3:

