

ASSEMBLY INSTRUCTIONS

30" WIDE STORAGE CABINET

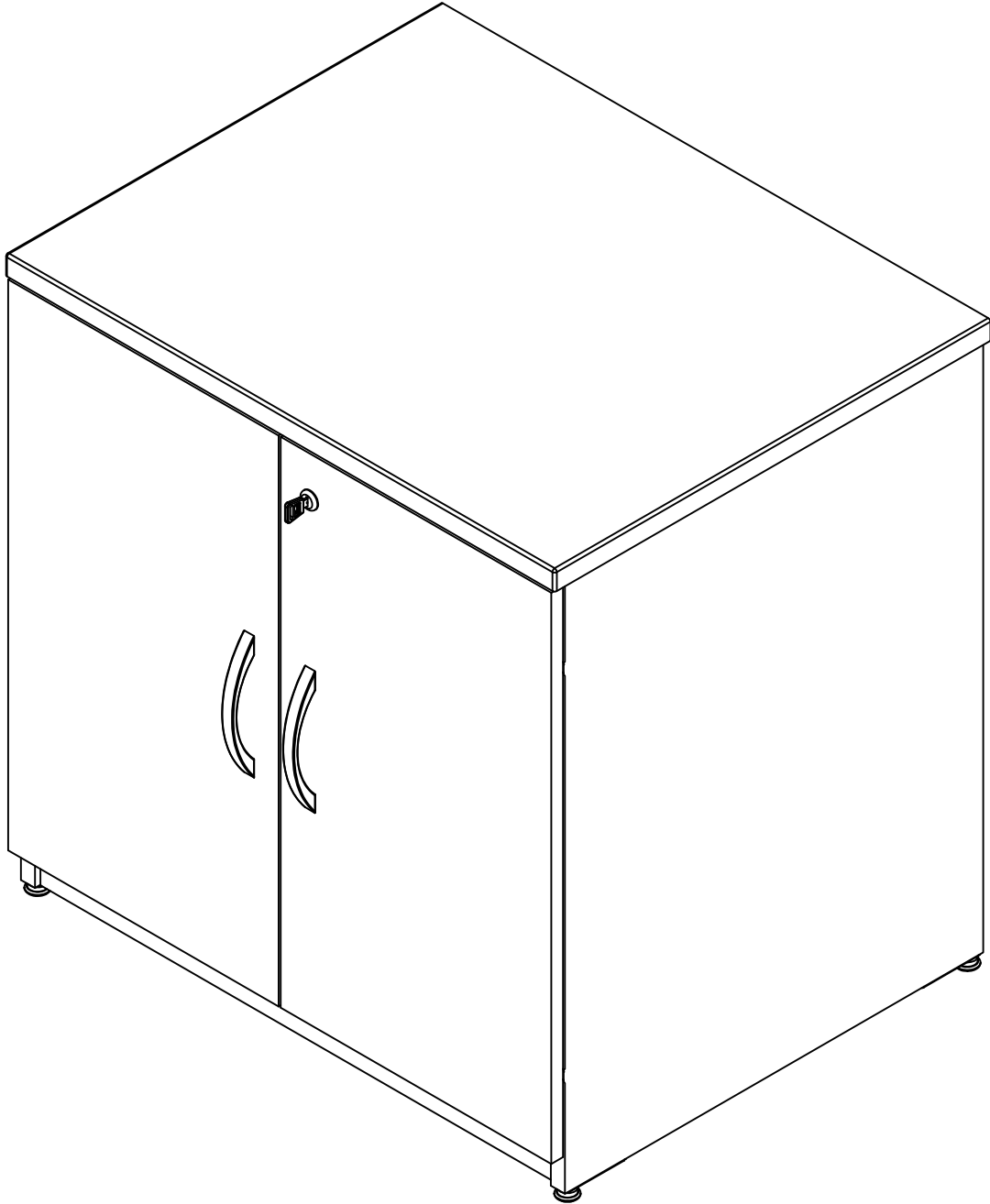

NEED HELP?
Call 1-800-950-4782
www.bushbusinessfurniture.com

Lot Code #

**WARNING**

This product is designed and intended for use with computer, fax, and printer equipment only. Improper loading with television or other heavy equipment could cause instability, tip over, and/or serious injury.

Este producto esta diseñado solamente para el uso con computadores, faxes, e impresoras. Inapropiado uso al poner televisores u otro equipo pesado puede causar inestabilidad, rodamiento, y/o herida (golpes) serios.

Ce produit est uniquement conçu pour une utilisation avec un ordinateur, un télécopieur, ou une imprimante. Un chargement incorrect avec une télévision ou autre matériel lourd peut le rendre instable ou le renverser, et peut vous causer des endommagements sérieux.

**WARNING**

Do not move unit when loaded. Doing so could cause instability, product collapse, tip over, and/or serious injury.

No mueva la unidad cuando esté cargada. Hacerlo puede causar inestabilidad, que el producto se derrumbe, que se la caiga encima y/o heridas (golpes) serias.

Ne pas déplacer l'unité lorsqu'ell est chargée. Faire ainsi peut causer l'instabilité, l'effondrement ou le renversement du meuble et/ou des endommagements sérieux.

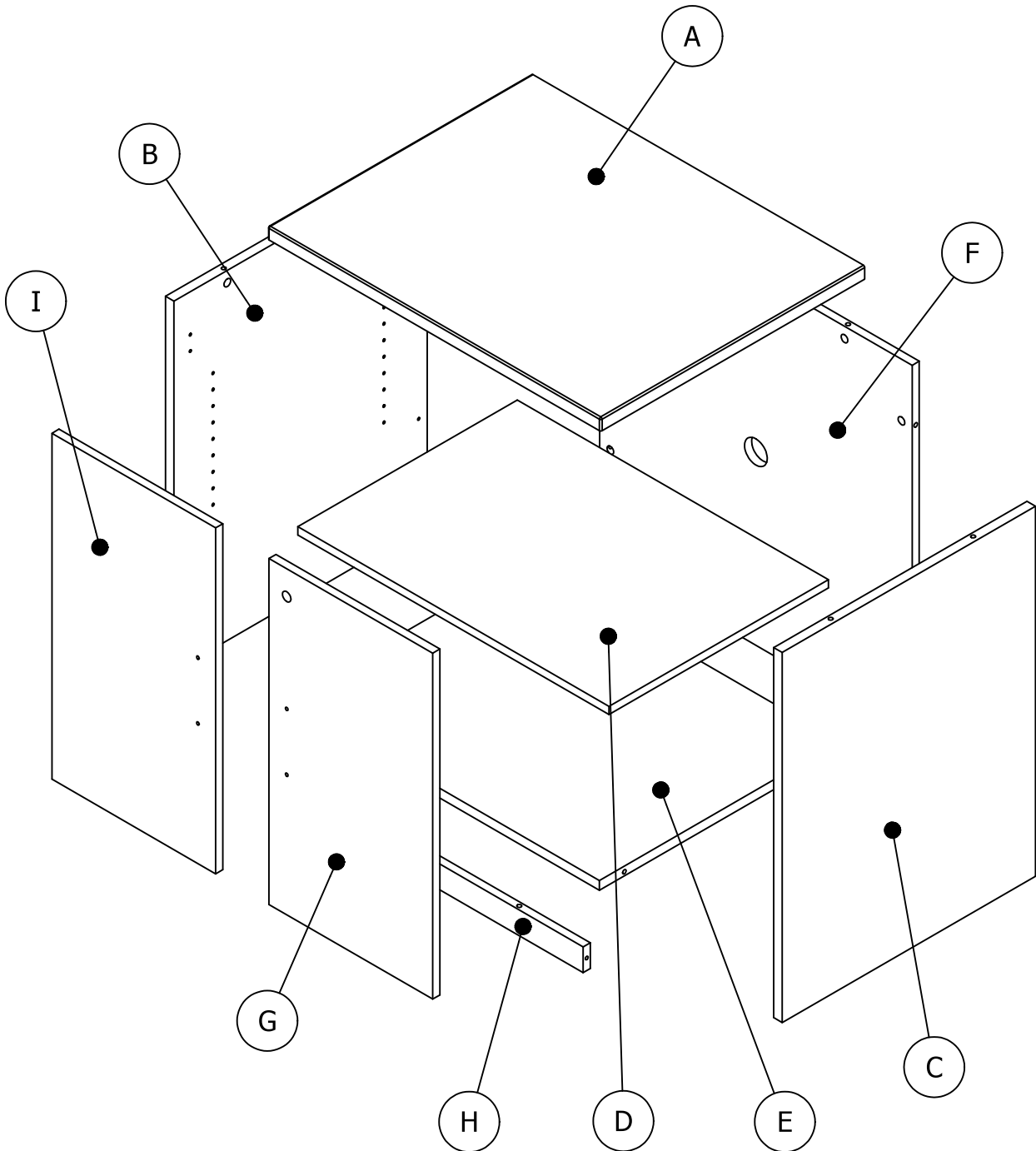
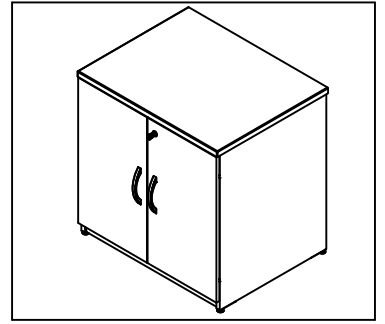

WC12996A

A	[1]	W151245
B	[1]	W183308
C	[1]	W183313
D	[1]	W129016
E	[1]	W129017
F	[1]	W129018
G	[1]	W151247
H	[1]	W183318
I	[1]	W151246

WC24496A

A	[1]	W173784
B	[1]	W183309
C	[1]	W183314
D	[1]	W129974
E	[1]	W129975
F	[1]	W129976
G	[1]	W151222
H	[1]	W183319
I	[1]	W151221

WC36796A

A	[1]	W151248
B	[1]	W183310
C	[1]	W183315
D	[1]	W129026
E	[1]	W129027
F	[1]	W129028
G	[1]	W151250
H	[1]	W183320
I	[1]	W151249

WC48596A

A	[1]	W173803
B	[1]	W183309
C	[1]	W183314
D	[1]	W129974
E	[1]	W129975
F	[1]	W129976
G	[1]	W151295
H	[1]	W183319
I	[1]	W151296

WC60396A

A	[1]	W151251
B	[1]	W183311
C	[1]	W183316
D	[1]	W129036
E	[1]	W129037
F	[1]	W129038
G	[1]	W151253
H	[1]	W183321
I	[1]	W151252

WC67596

A	[1]	W173820
B	[1]	W183312
C	[1]	W183317
D	[1]	W152045
E	[1]	W152046
F	[1]	W152047
G	[1]	W152093
H	[1]	W183322
I	[1]	W152081

WC72496A

A	[1]	W151254
B	[1]	W183309
C	[1]	W183314
D	[1]	W129974
E	[1]	W129975
F	[1]	W129976
G	[1]	W151256
H	[1]	W183319
I	[1]	W151255

Fasteners are shown in actual size.
 los fijadores son demostrados en su tamaño actual.
 les attaches sont montrées dans l'échelle grandeur.

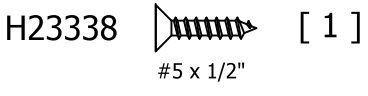
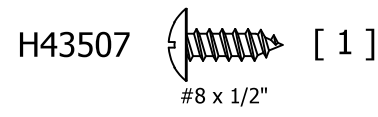
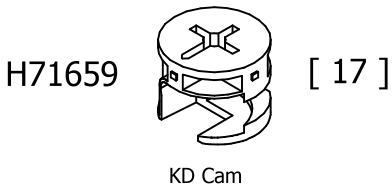
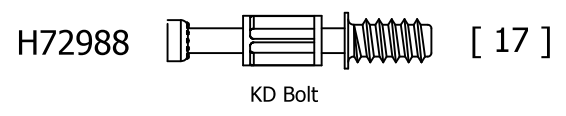
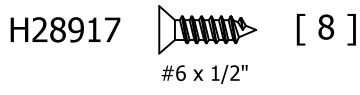
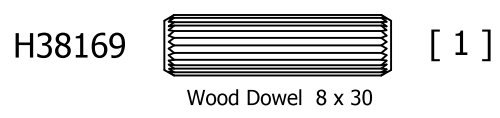
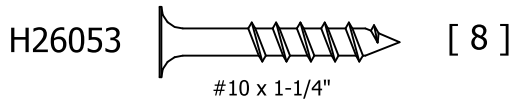

WC12996A,WC36796A
 WC60396A

WC24496A,WC48596A
 WC67596,WC72496A

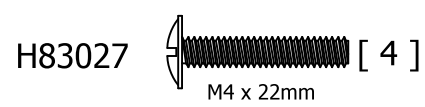
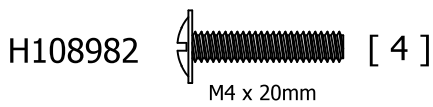

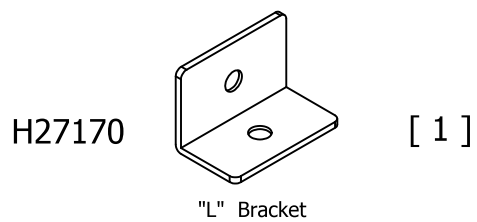
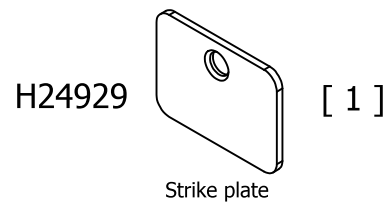
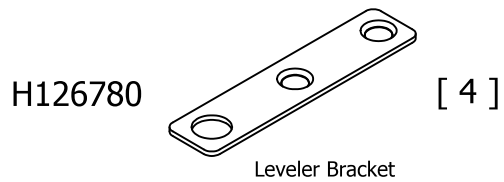
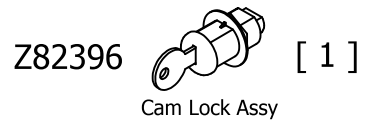
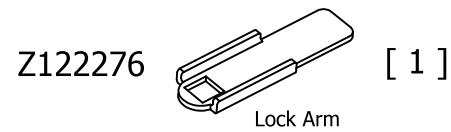
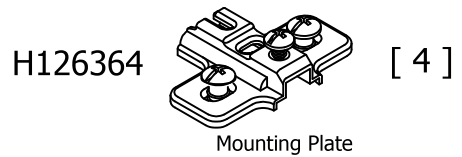
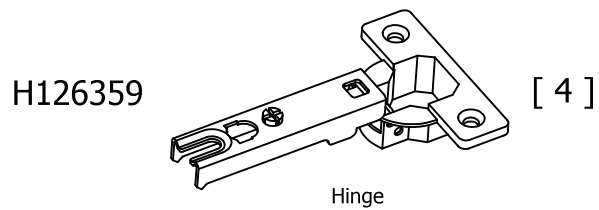
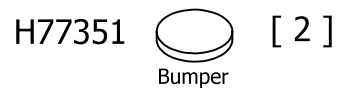
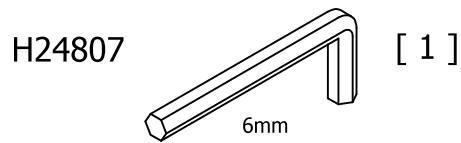
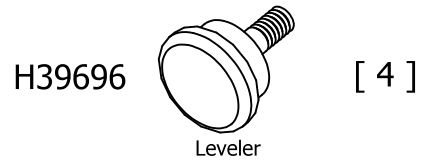
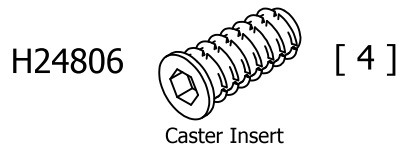
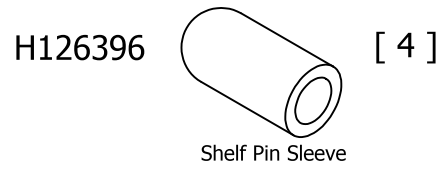
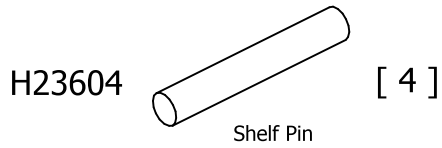

WC24496A WC48596A WC72496A

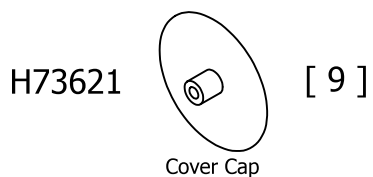
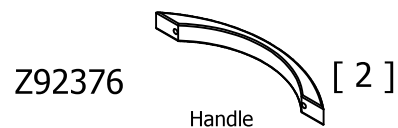
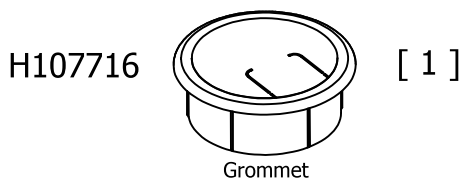
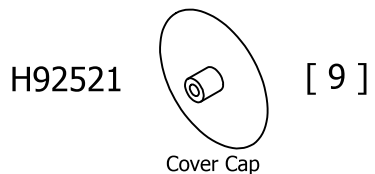

WC12996A

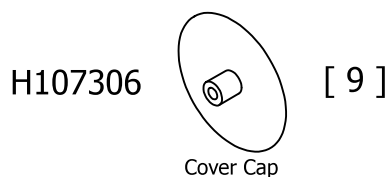
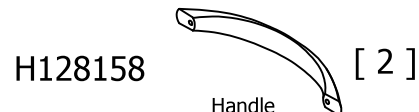
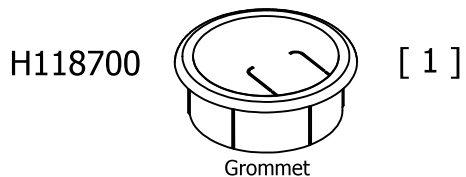

WC36796A

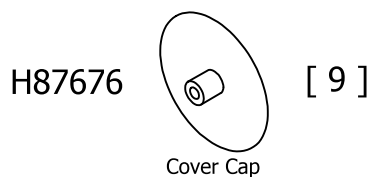
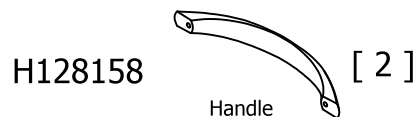
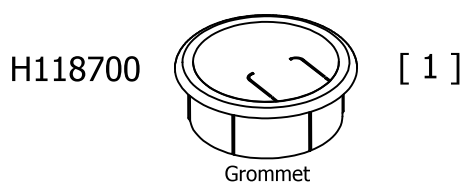

WC60396A

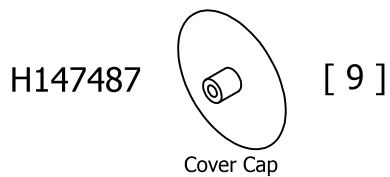
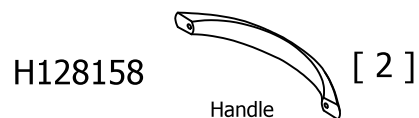
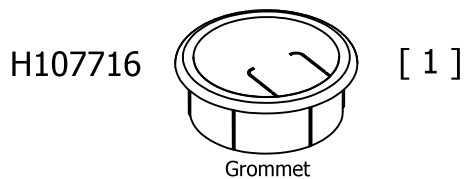

WC67596

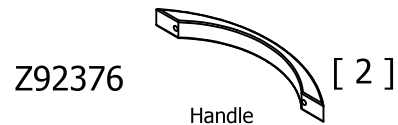
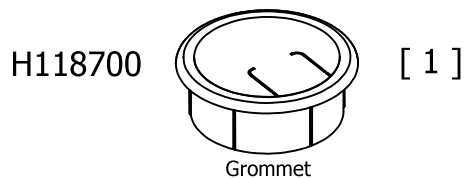

Common assembly techniques.
 Técnica común de ensamblaje.
 Techniques communes d'assemblage.

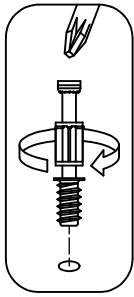

- Use a screwdriver with H72988.
- Favor de usar un desarmador con el tornillo H72988.
- Utilisez un tournevis avec H72988.

- Wood dowel installation.
- Instalación del tornillo de madera.
- Installation de chevilles de bois.

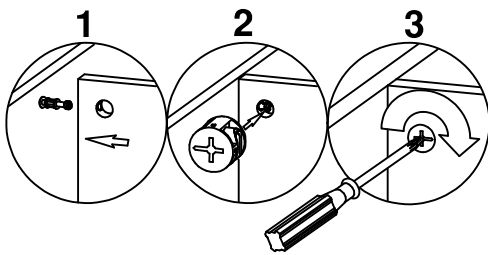
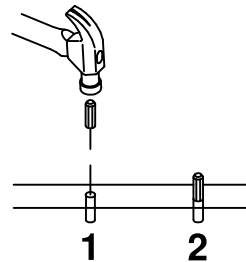

- Panel to panel attachment.
- Fijación de tablero con tablero.
- Fixation d'un panneau à l'autre

- Wood dowel installation with glue.
- Instalación del tornillo de madera con pegamento.
- Installation de chevilles de bois avec la colle.

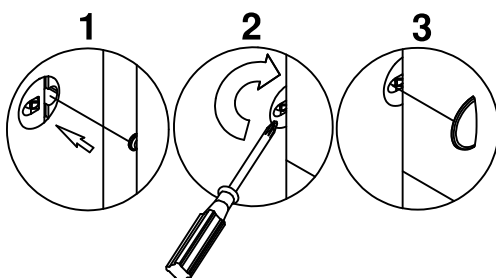
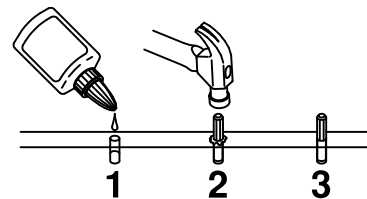

- Panel to panel attachment.
- Fijación de tablero con tablero.
- Fixation d'un panneau à l'autre

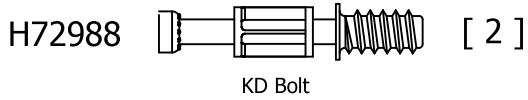
**Notice:**

If you purchased the WC12997, WC24497, WC36797, WC48597, WC60397, WC67597, WC72497 Hutch, assemble the Hutch first then proceed with the assembly of the Cabinet.

Aviso:

Si usted ha comprado el hutch modelo WC12997, WC24497, WC36797, WC48597, WC60397, WC67597, WC72497 complete el ensamblaje del mismo primero y luego complete el ensamblaje del gabinete.

Avis:

Si vous avez acheté le surmeuble WC12997, WC24497, WC36797, WC48597, WC60397, WC67597, WC72497, assemblez d'abord le surmeuble puis passez à l'assemblage du Cabinet.

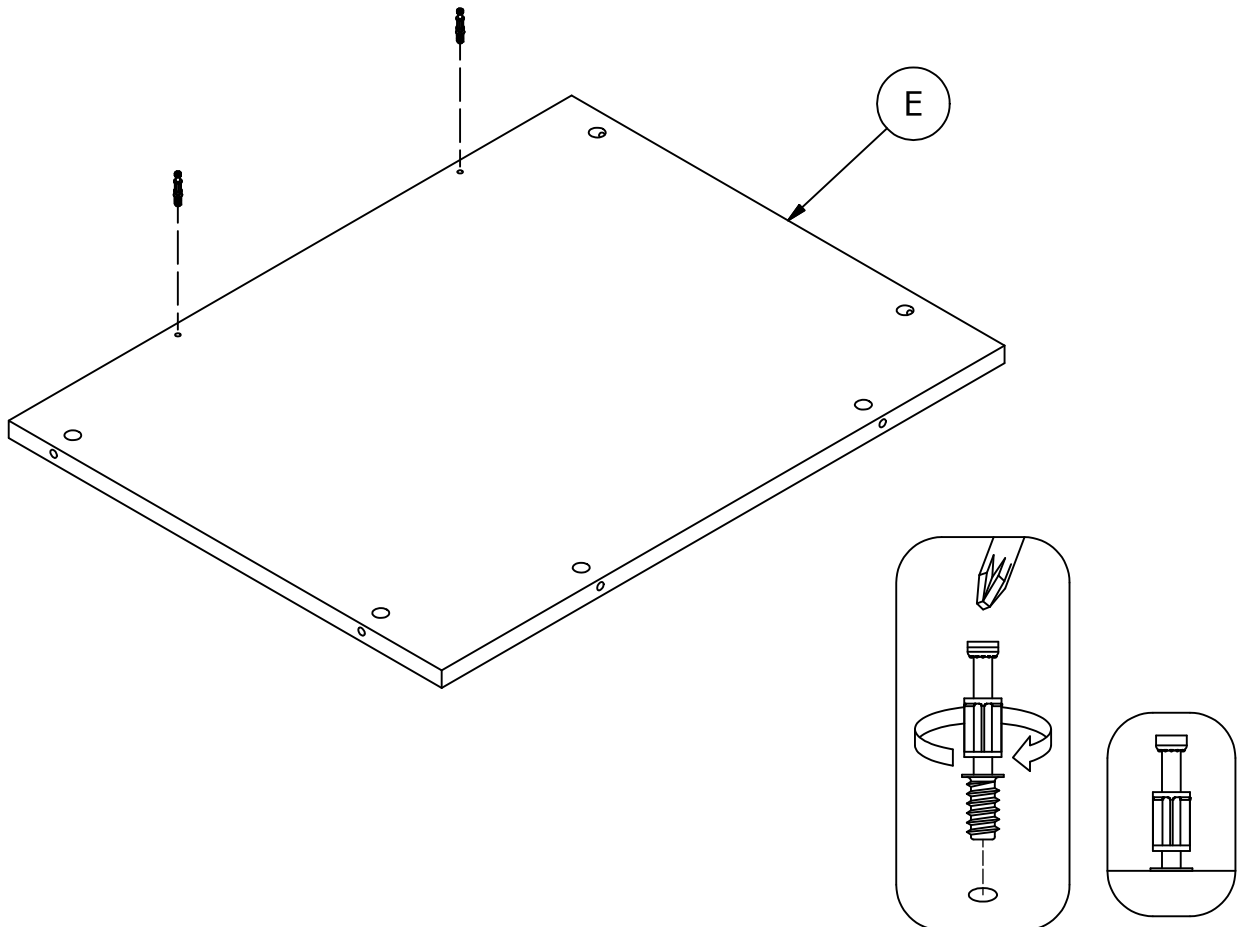

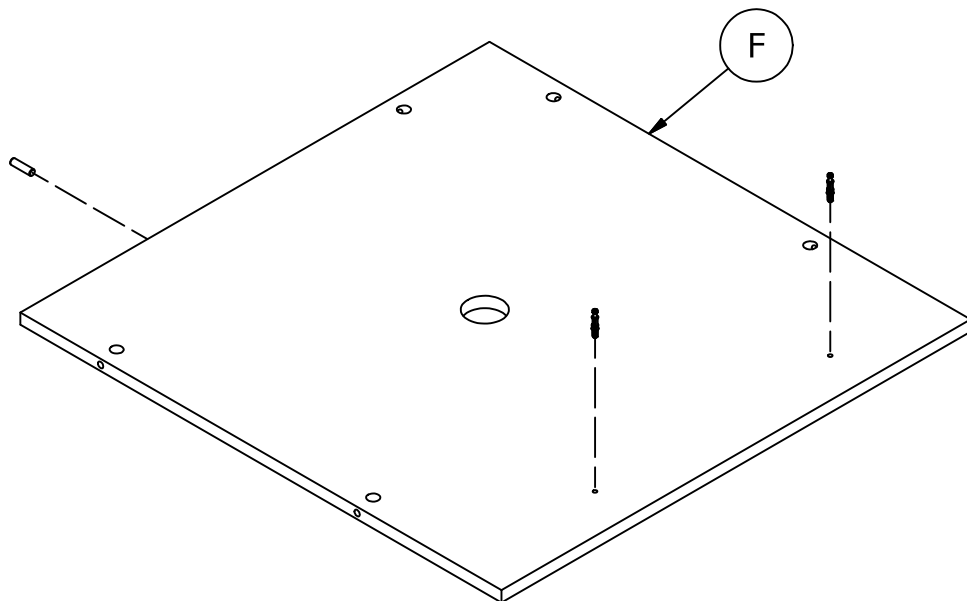
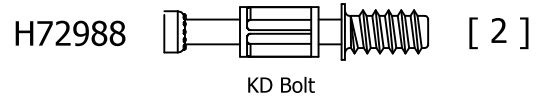
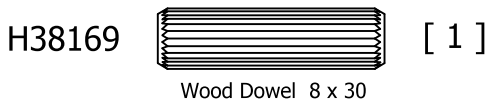
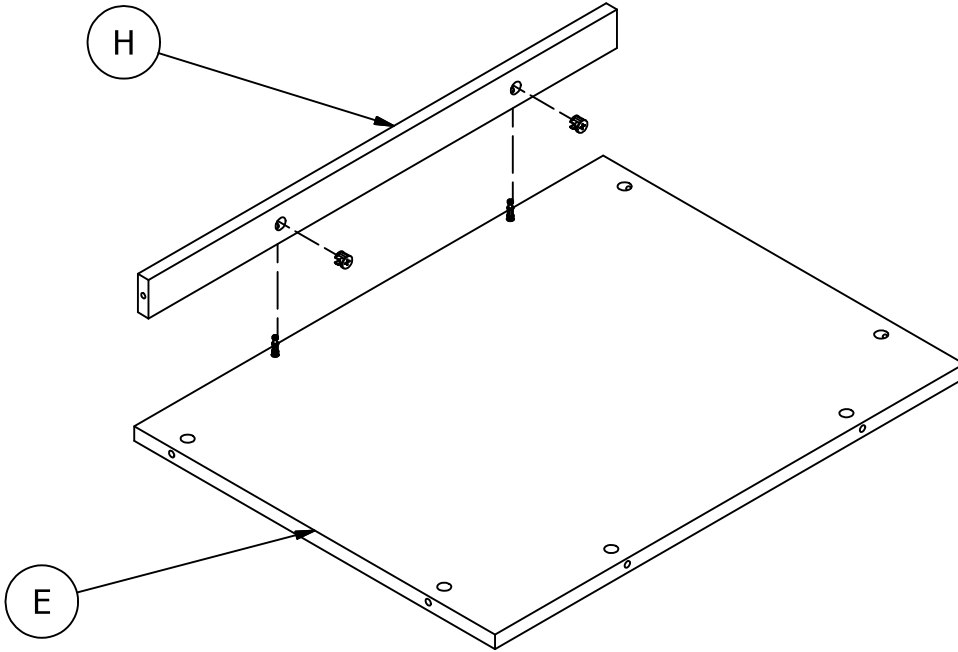
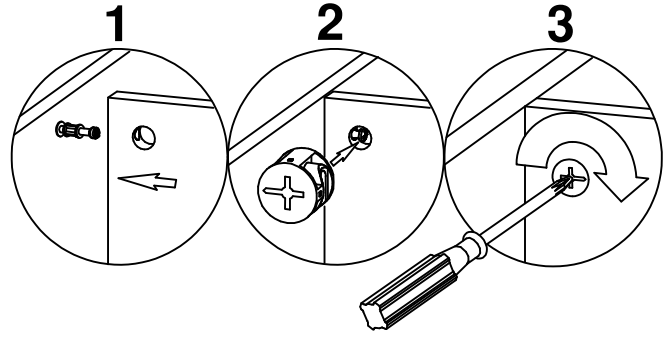
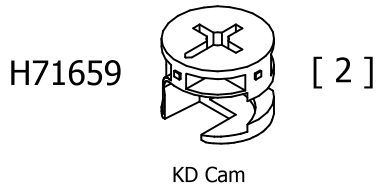

H71659

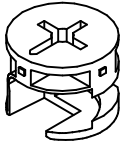

[2]

KD Cam

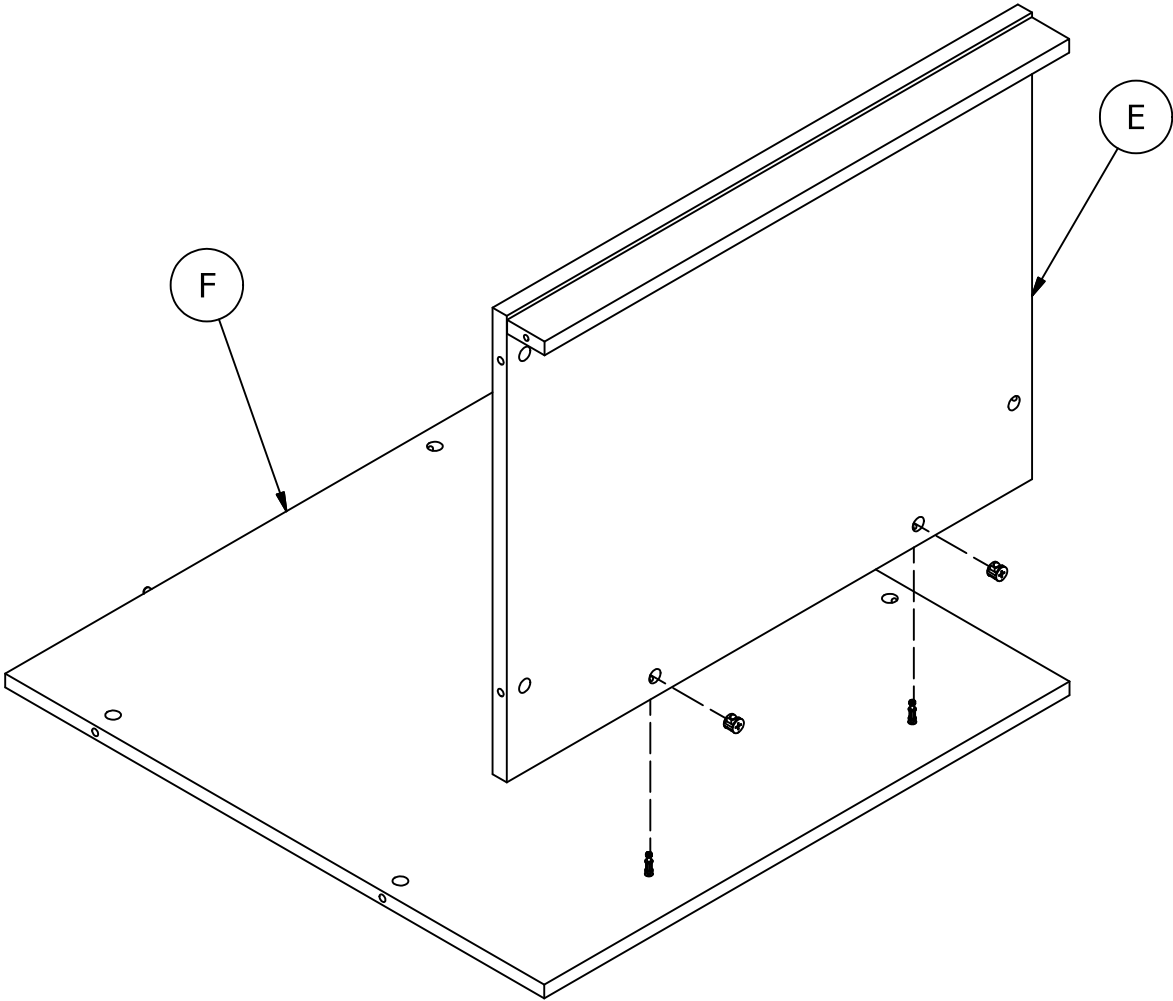

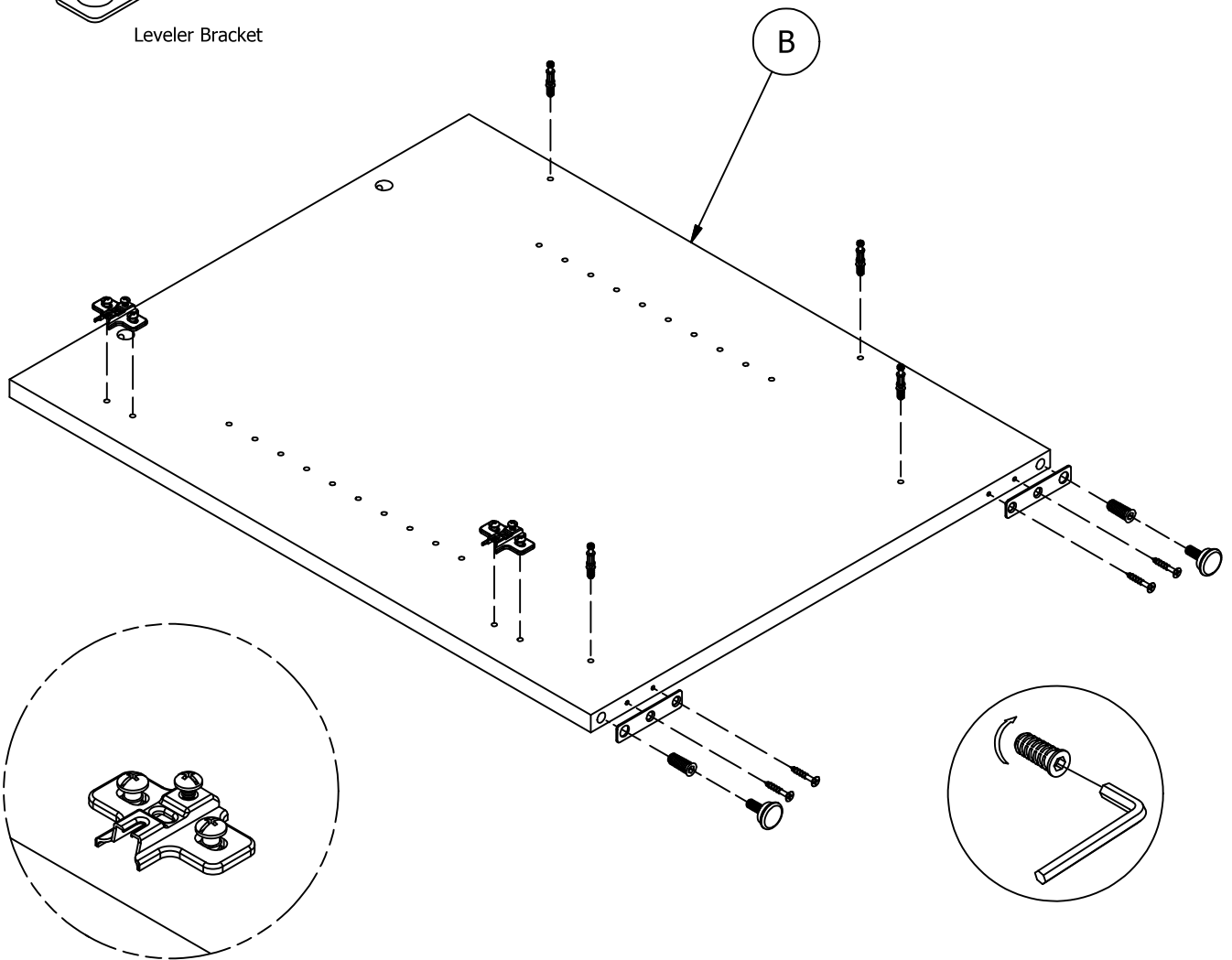
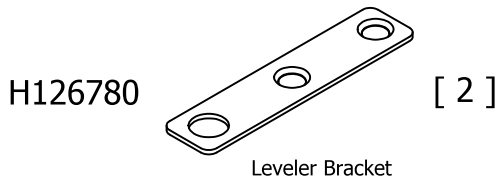
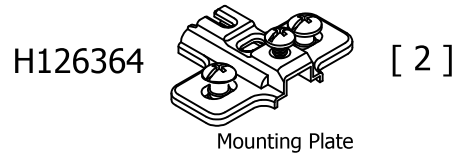
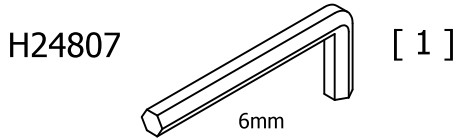
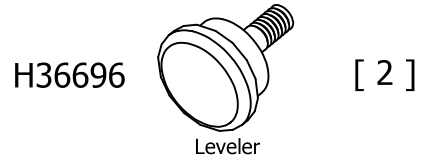
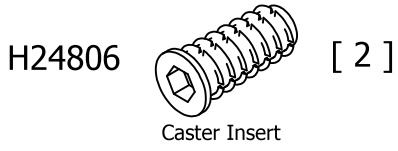
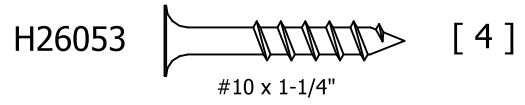
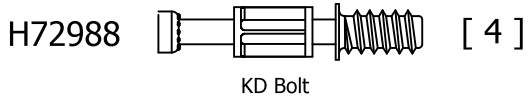

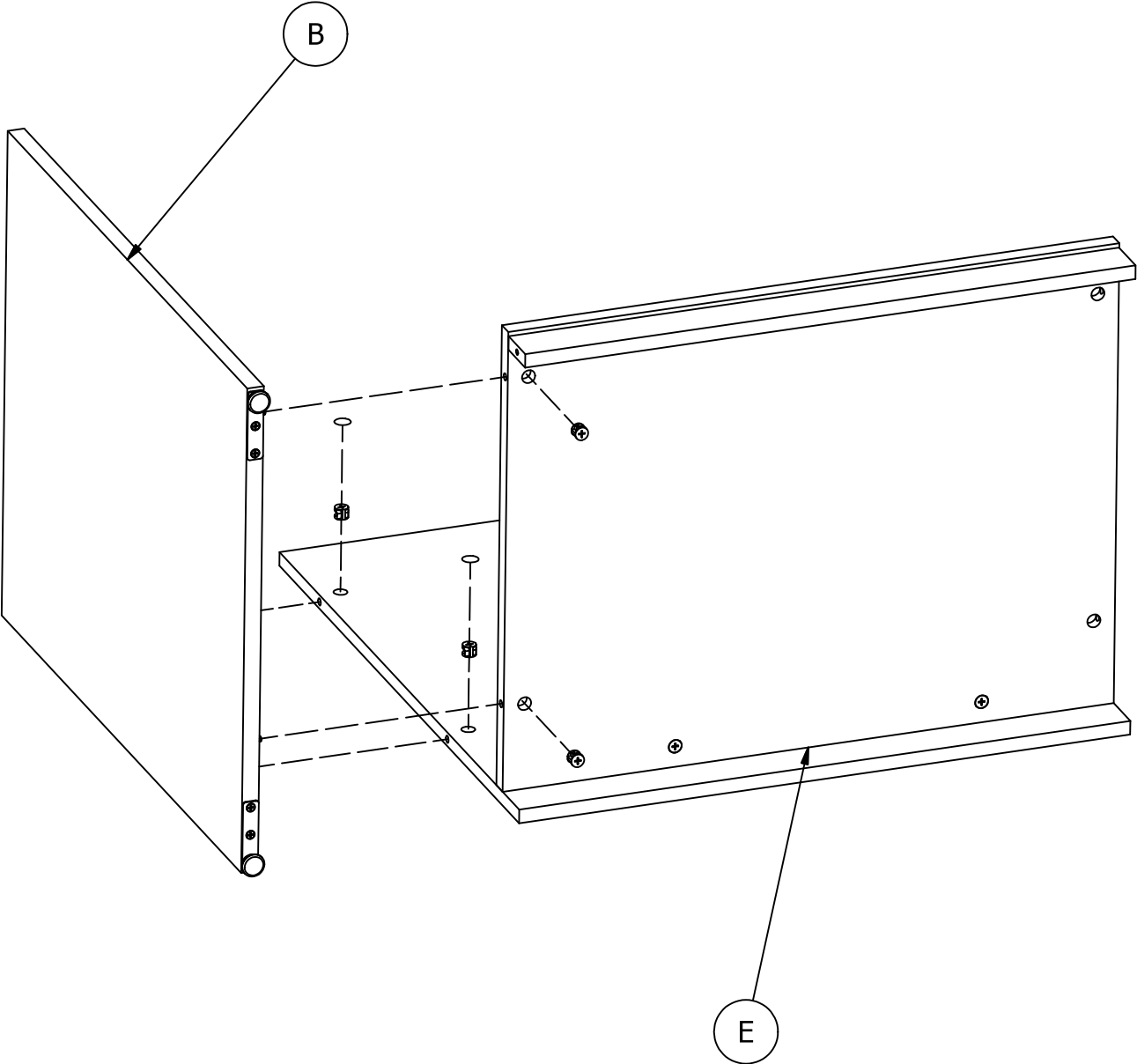
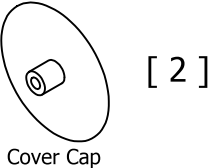
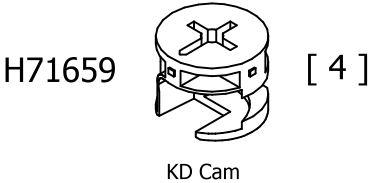

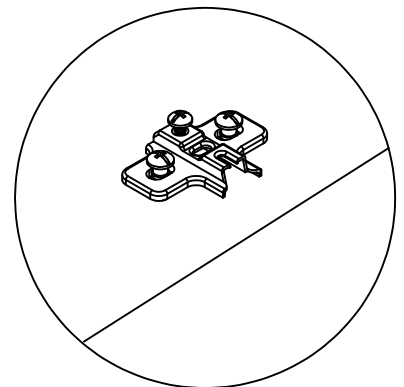
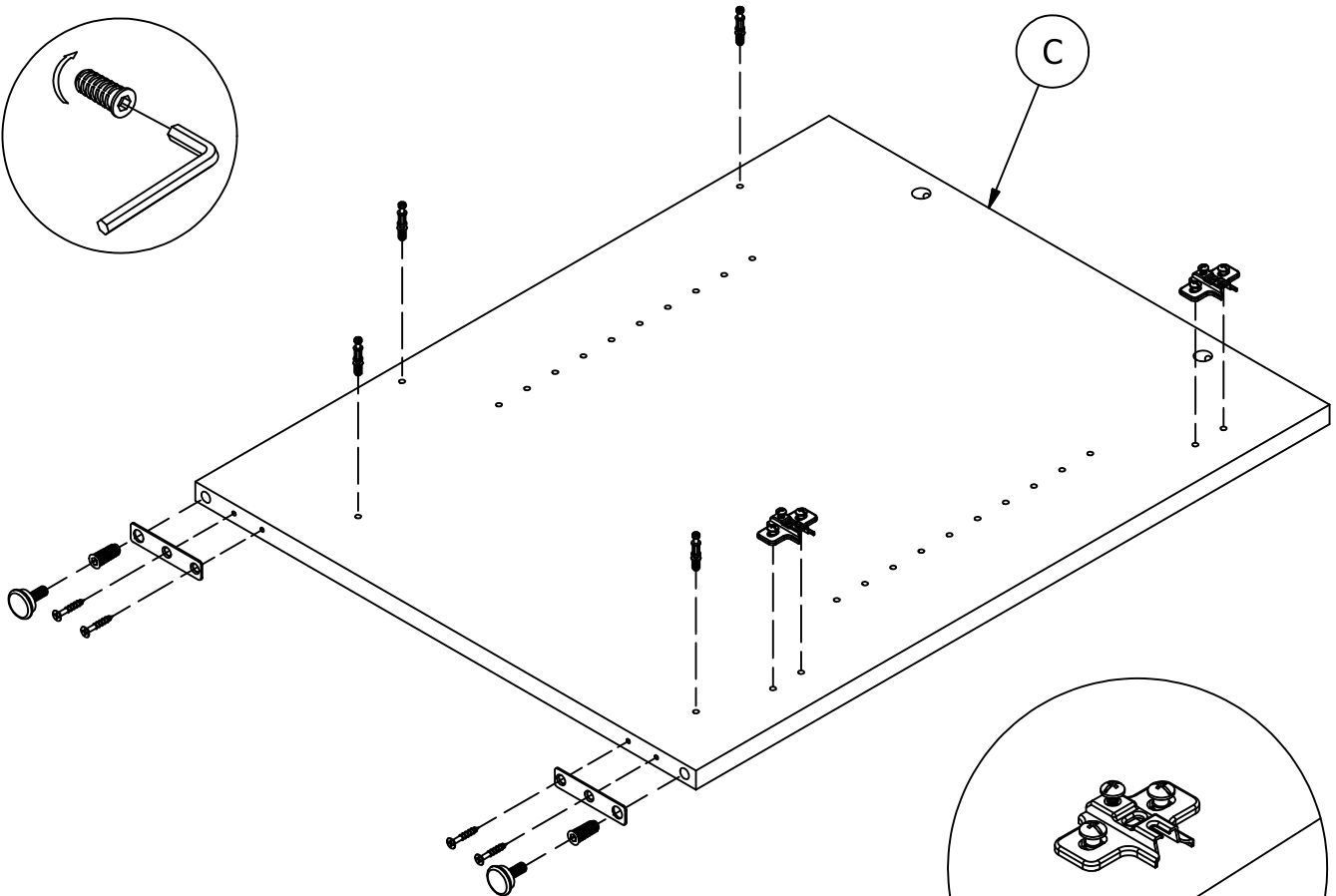
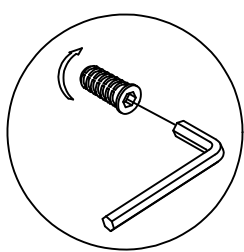
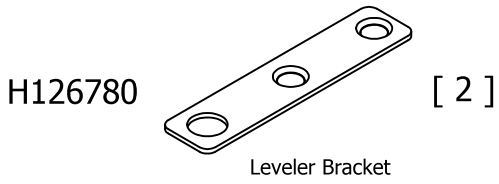
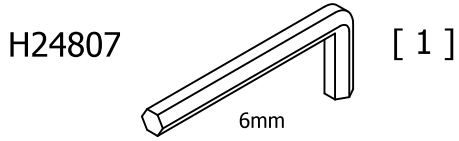
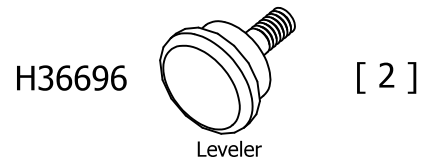
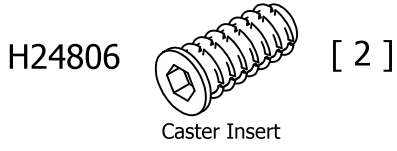
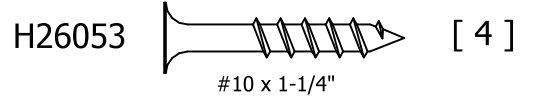
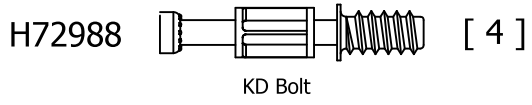

H71659 [4]
KD Cam

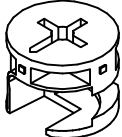

[2]
Cover Cap

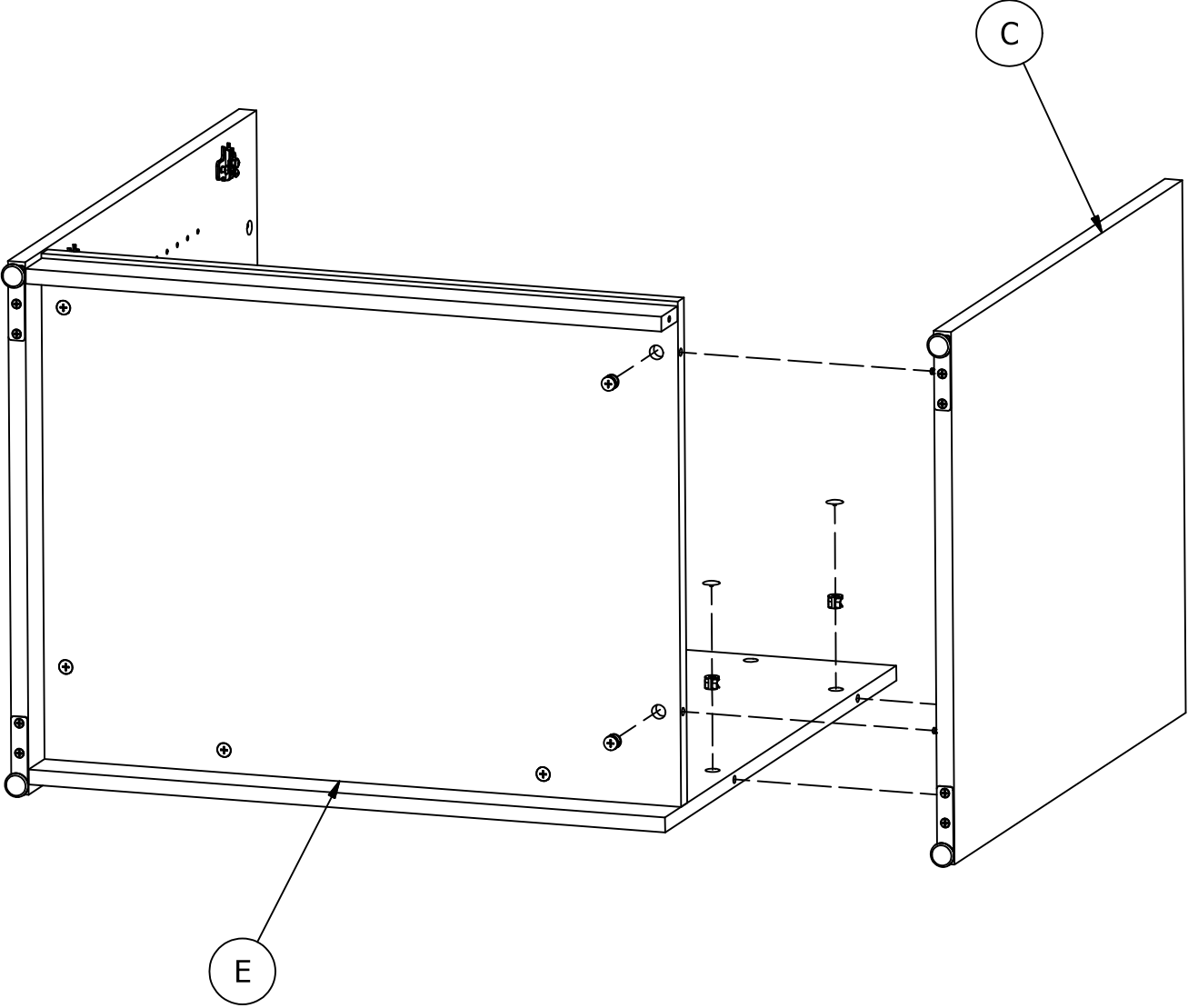
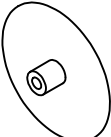

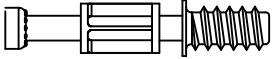
H72988  [5]
KD Bolt

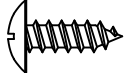
H43507  [1]
#8 x 1/2"

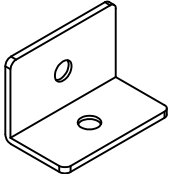
H27170  [1]
"L" Bracket

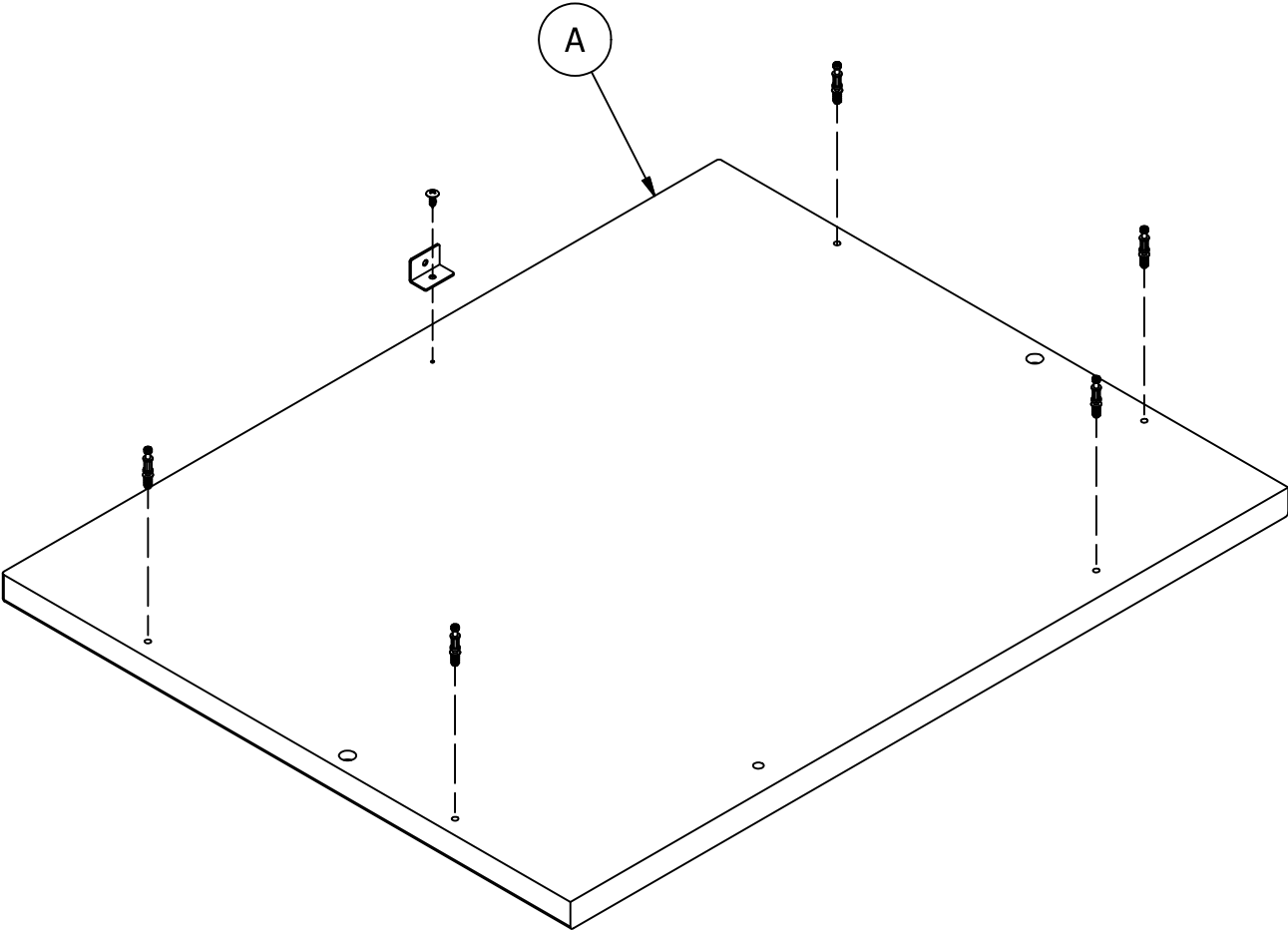

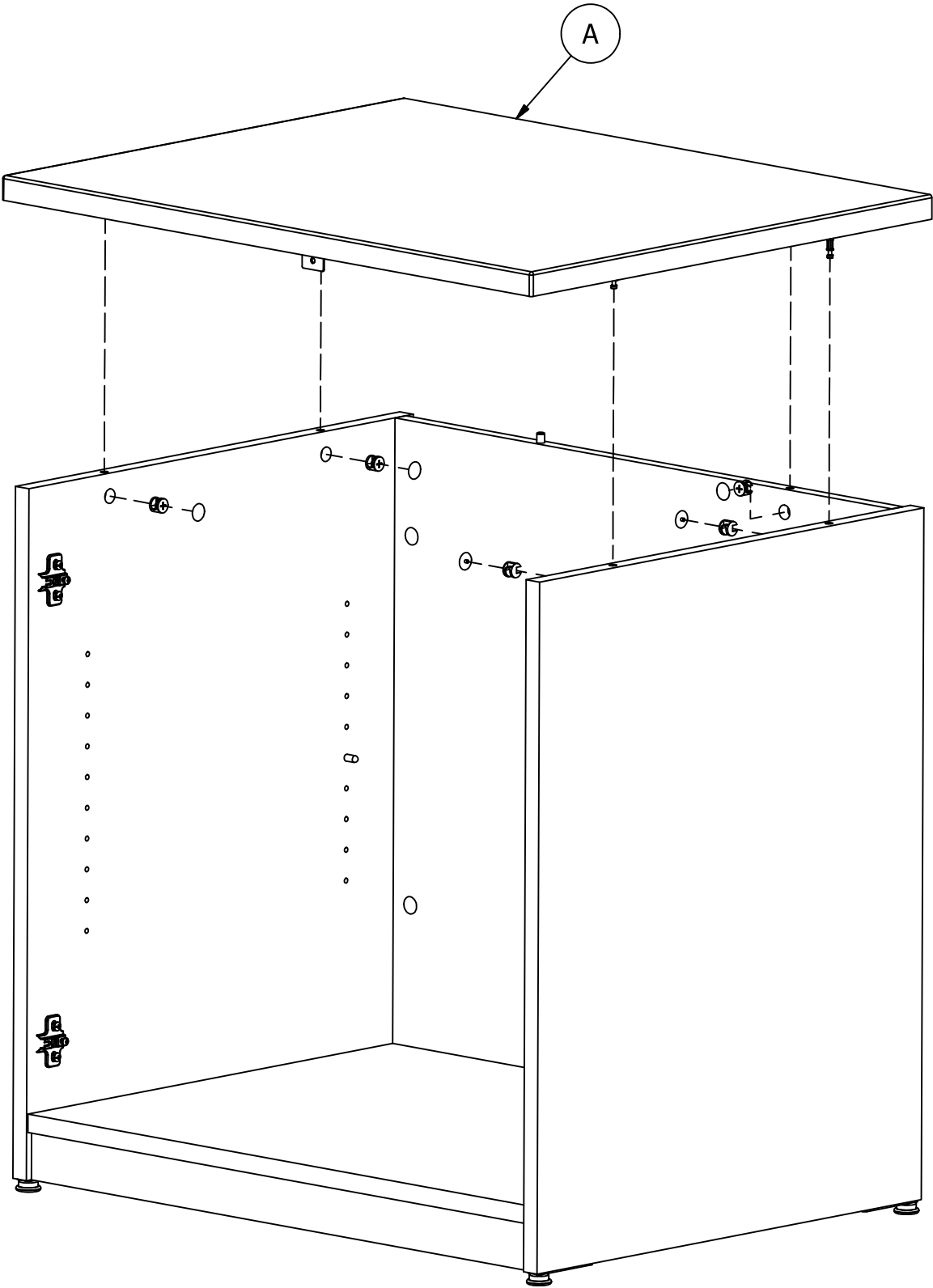
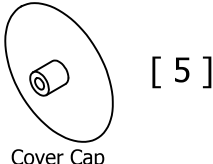
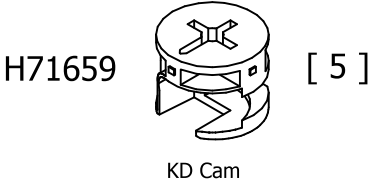

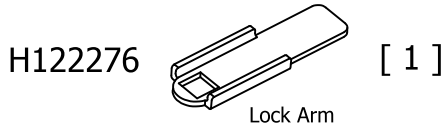
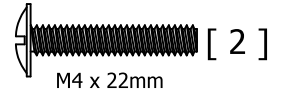
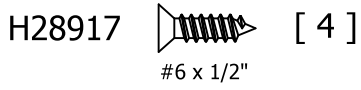
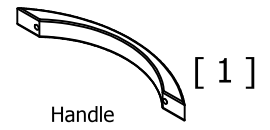
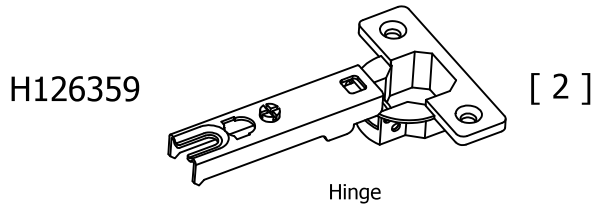

Unlock
Abra
Deverouillage

Lock
Cierre con llave
Verouillage

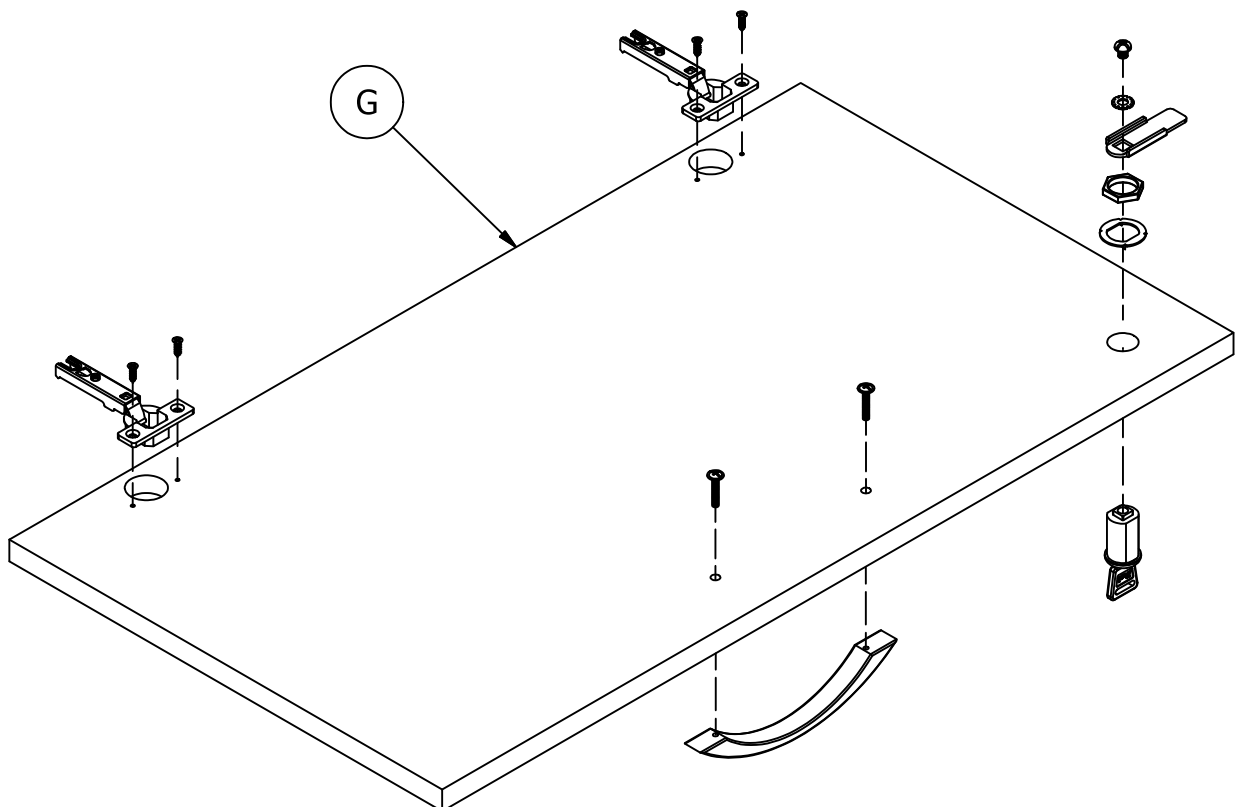
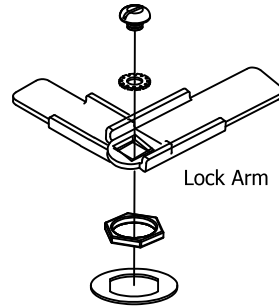

H126359

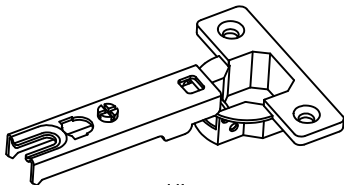

[2]

Hinge

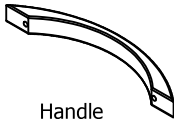

[1]

Handle

H28917



[4]

#6 x 1/2"

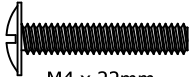

[2]

M4 x 22mm

H24929

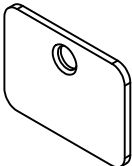

[1]

Strike plate

H23338

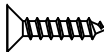

[1]

#5 x 1/2"

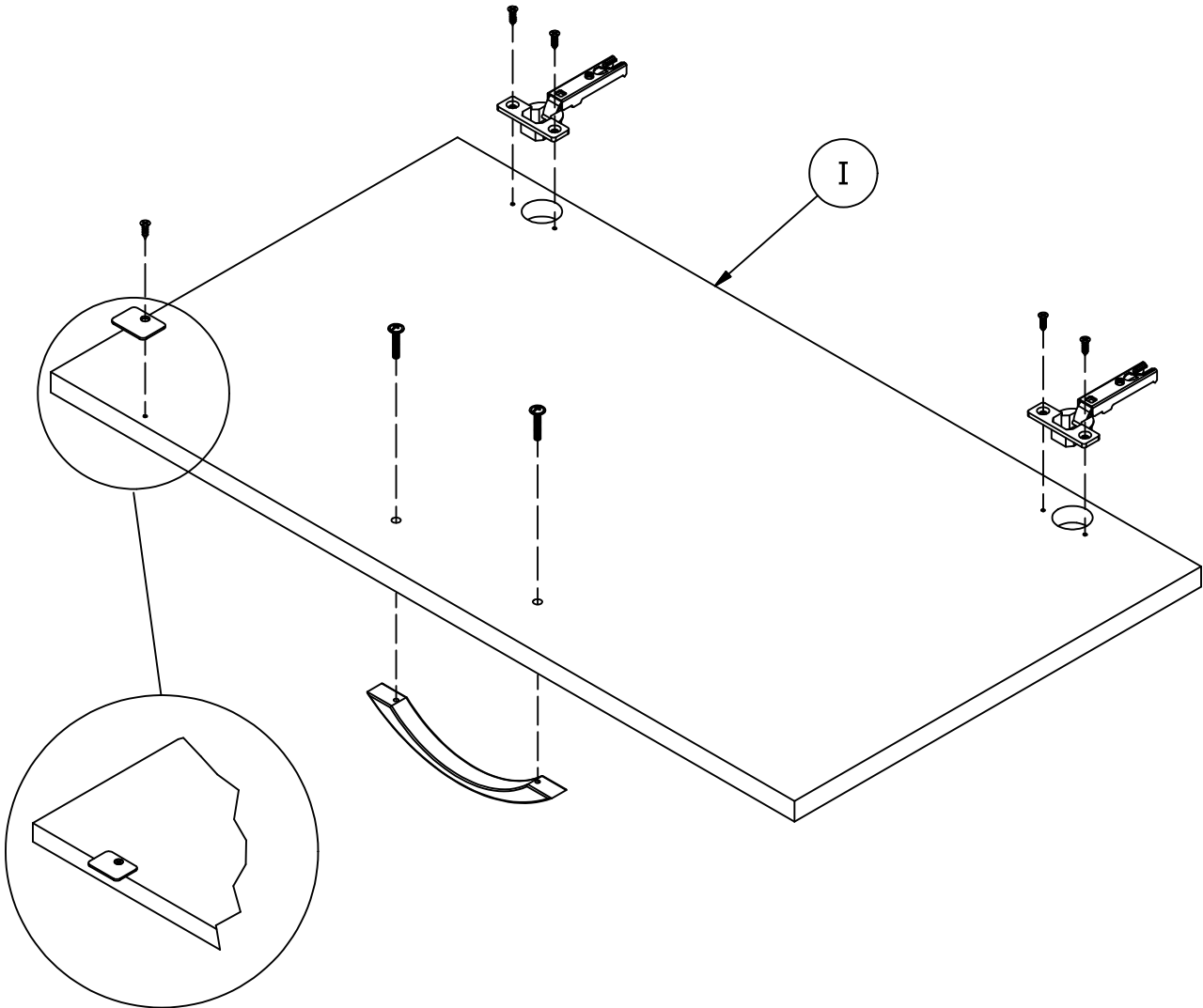

H77351 [2]
Bumper

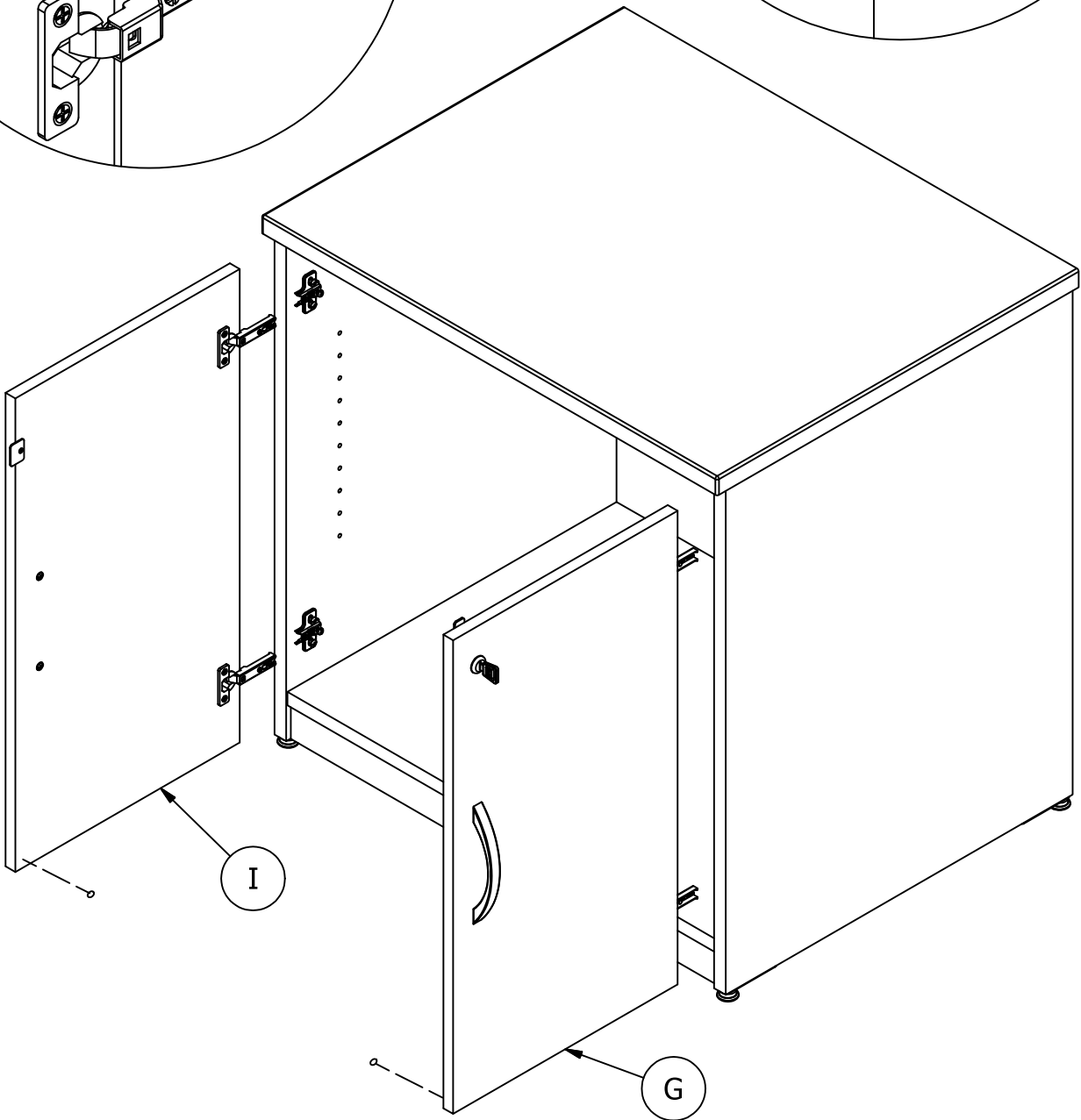
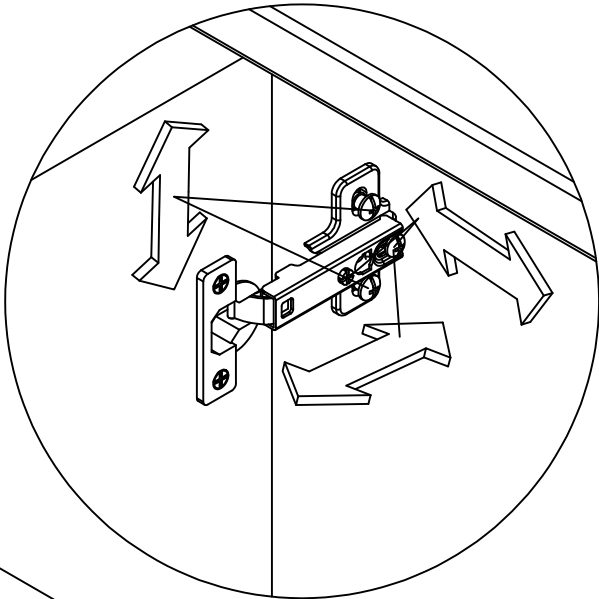
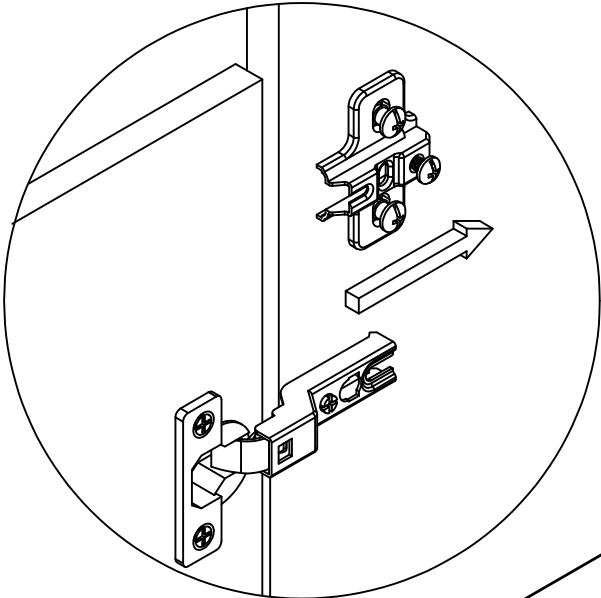

H23604 [4]
Shelf Pin

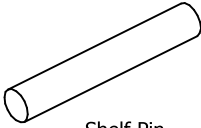

H126396 [4]
Shelf Pin Sleeve

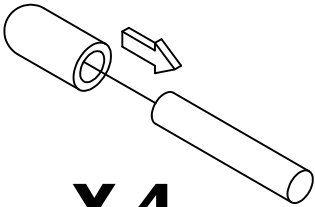
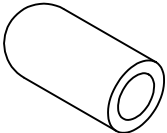

X 4

[1]
Grommet

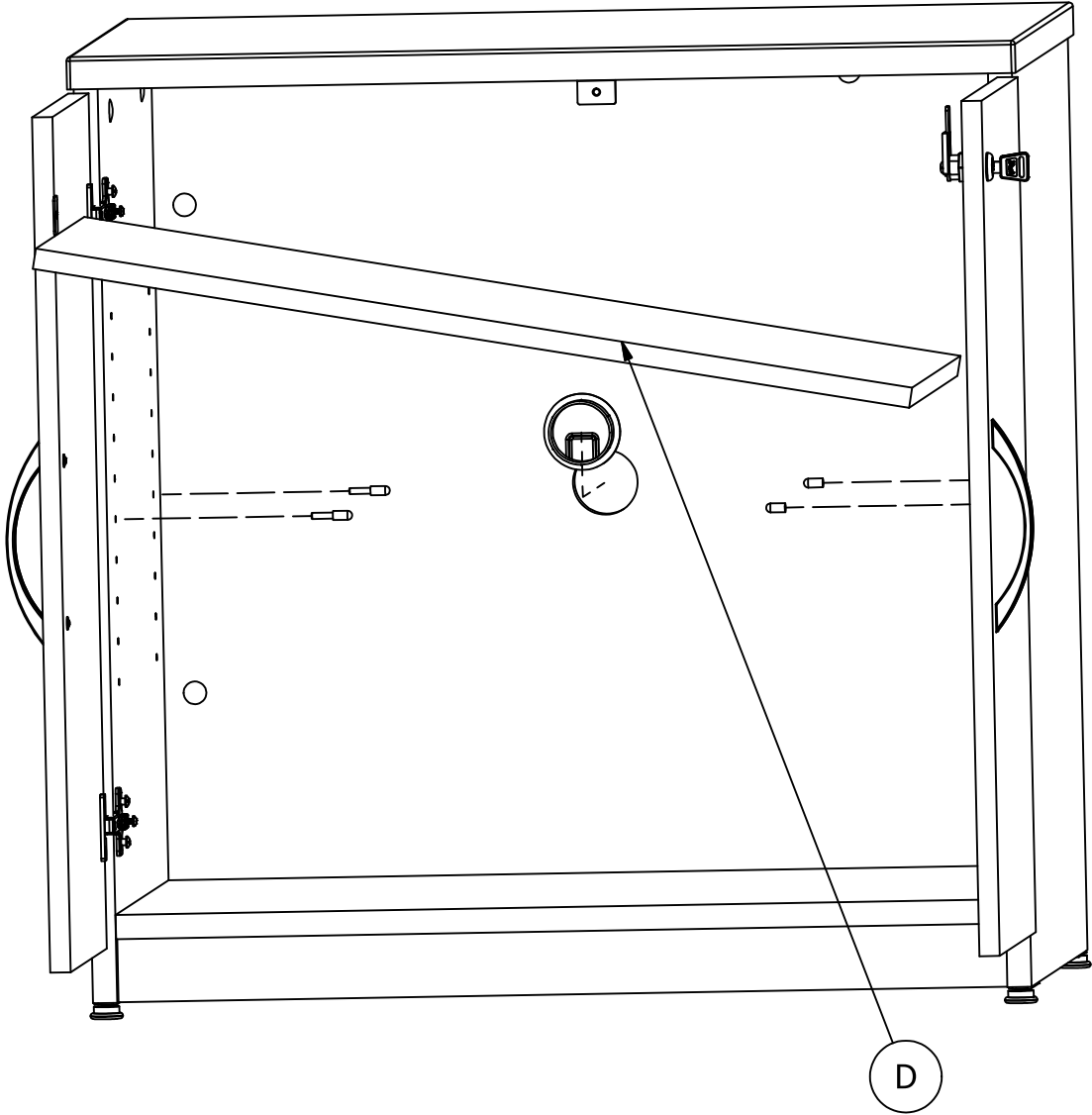
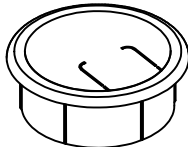

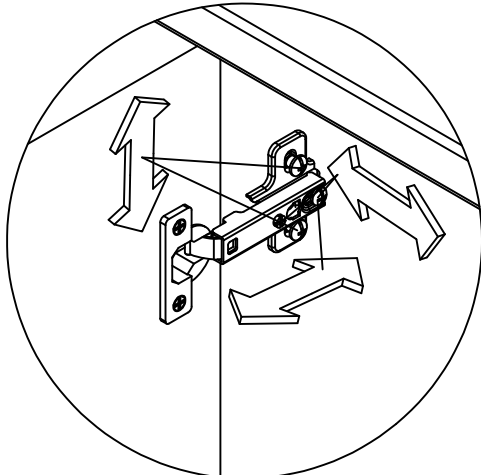

Maximum Weight: 125 Lbs.
Peso Máximo: 125 Libras
Poids Maximum: 56.7 kilogramme

Maximum Weight: 50 Lbs.
Peso Máximo: 50 Libras
Poids Maximum: 22.7 kilogramme

