

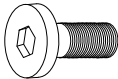



LISBON-GREY/BLACK-BOOKCASE FB/QB ASSEMBLY INSTRUCTION

HARDWARE LIST

ITEM	DESCRIPTION	DRAWING	QTY
1	JCBB SCREW (M8 x 16MM)		8 PCS
2	JCBC SCREW (M6 x 35MM)		8 PCS
3	SPRING WASHER (M6 x 13MM)		8 PCS
4	FLAT WASHER (M6 x 19MM)		8 PCS
5	CSK SCREW (M4 x 32MM)		8 PCS
6	ALLEN KEY M5		1 PC
7	ALLEN KEY M4		1 PC
8	SHELF PIN		12 PCS

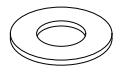
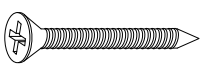
PART LIST

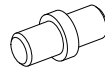
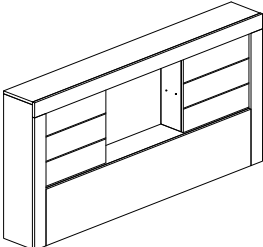
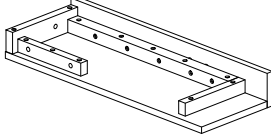
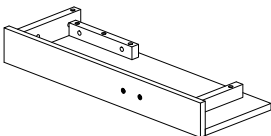
ITEM	DESCRIPTION	DRAWING	QTY
A	HEADBOARD		1 PC
B	HEADBOARD LEG (R)		1 PC
C	HEADBOARD LEG (L)		1 PC

LISBON-GREY/BLACK-BOOKCASE FB/QB ASSEMBLY INSTRUCTION

PART LIST

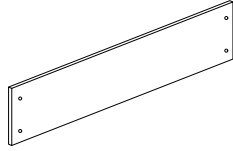
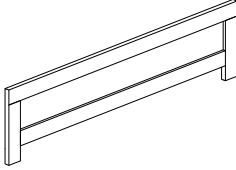
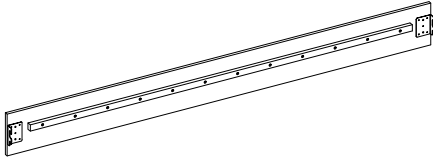
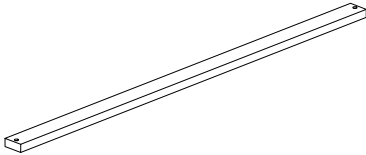
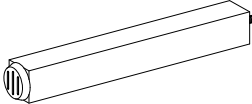
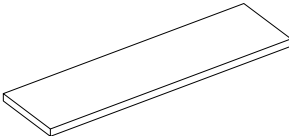
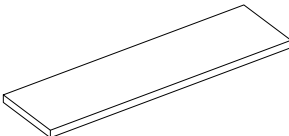
ITEM	DESCRIPTION	DRAWING	QTY
D	HEADBOARD BOTTOM PANEL		1 PC
E	FOOTBOARD		1 PC
F	SIDE RAIL		2 PCS
G	SLAT		4 PCS
H	CENTER SLAT SUPPORT		4 PCS
I	CENTER SHELF		1 PC
J	LEFT & RIGHT SHELF		2 PCS

ASSEMBLY TOOLS REQUIRED

1. Screwdriver (not provide)

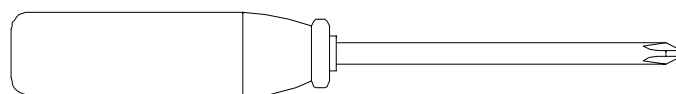

LISBON-GREY/BLACK-BOOKCASE FB/QB ASSEMBLY INSTRUCTION

ASSEMBLY STEPS

STEP 1

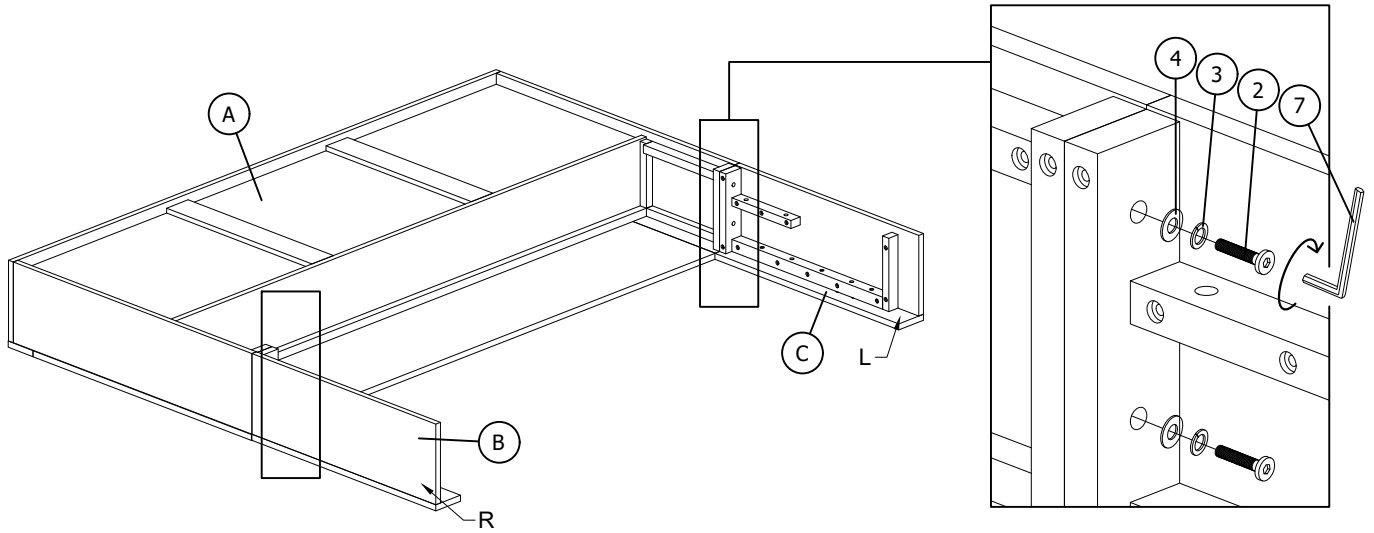

STEP 2

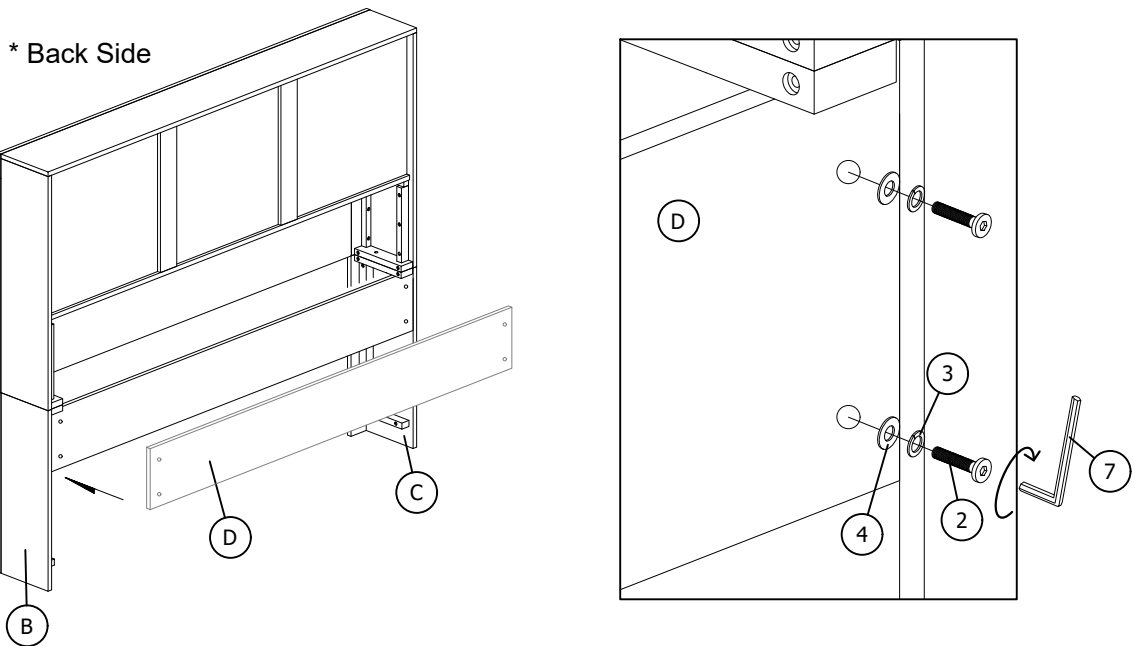

LISBON-GREY/BLACK-BOOKCASE FB/QB ASSEMBLY INSTRUCTION

STEP 3

This step needs to be done four times.

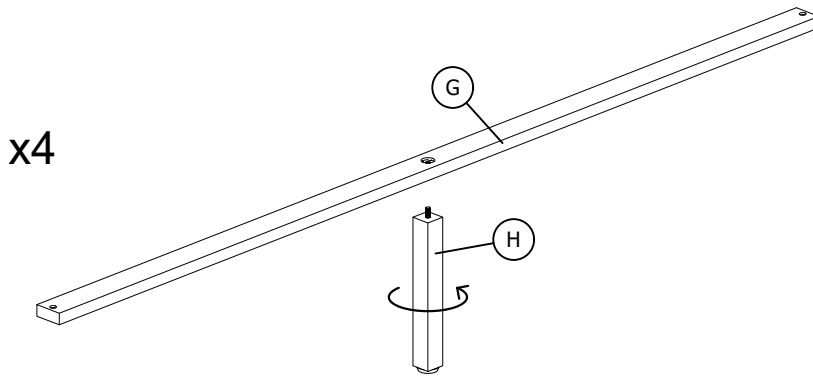

STEP 4

STEP 4.1 : Insert but do not tighten item (1).

STEP 4.2 : Attach item (F) with item (B),(C) and (E).

STEP 4.3 : Tighten item (1).

STEP 4.1

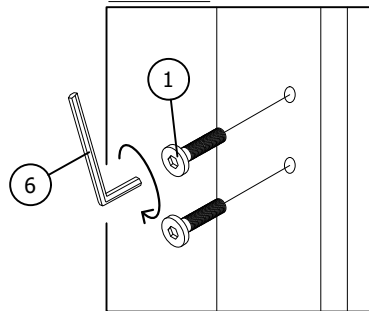

STEP 4.2

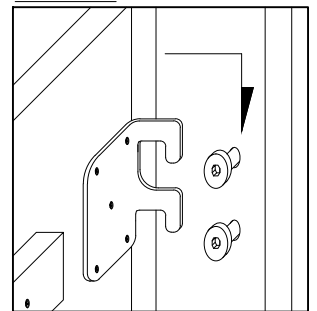

STEP 4.3

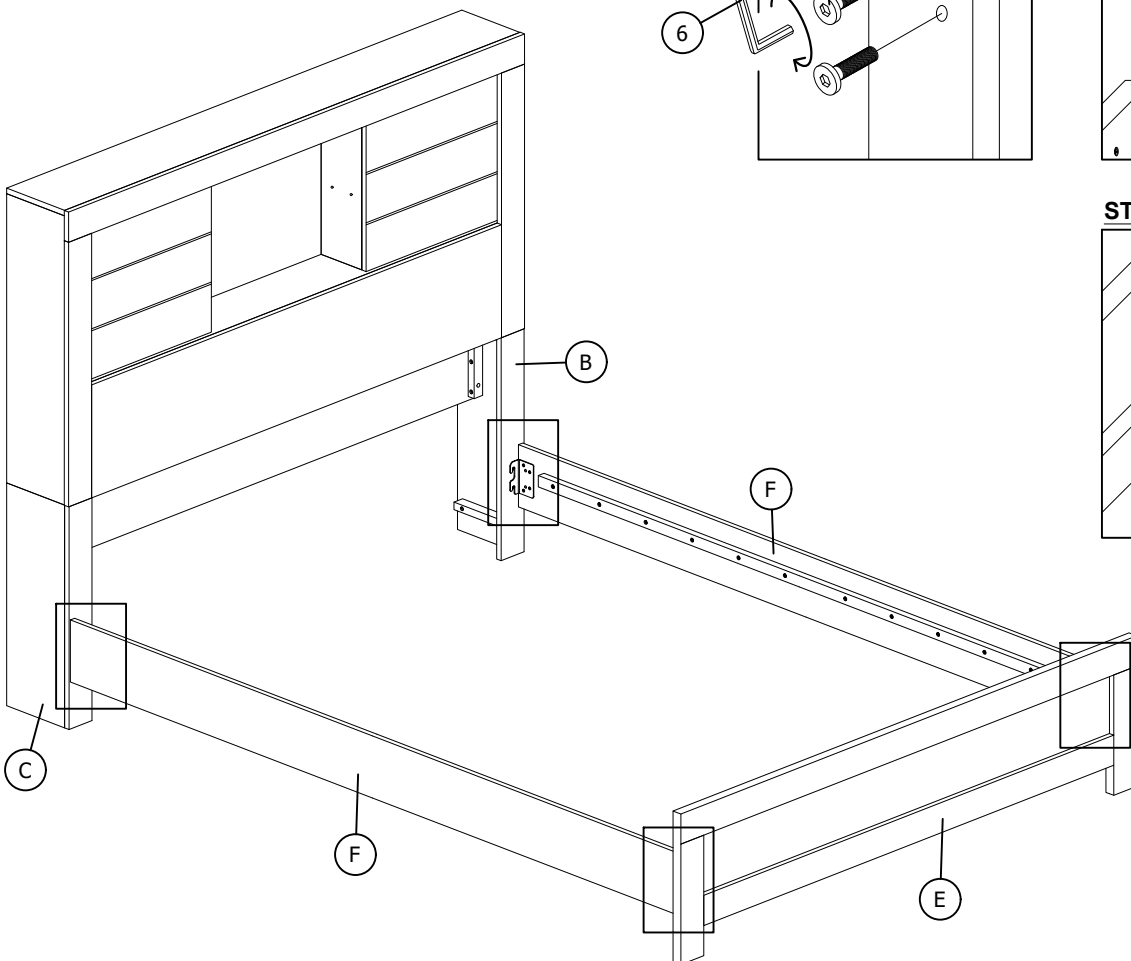
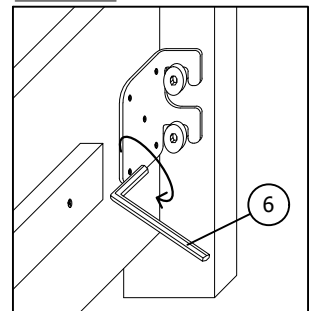

LISBON-GREY/BLACK-BOOKCASE FB/QB ASSEMBLY INSTRUCTION

STEP 5

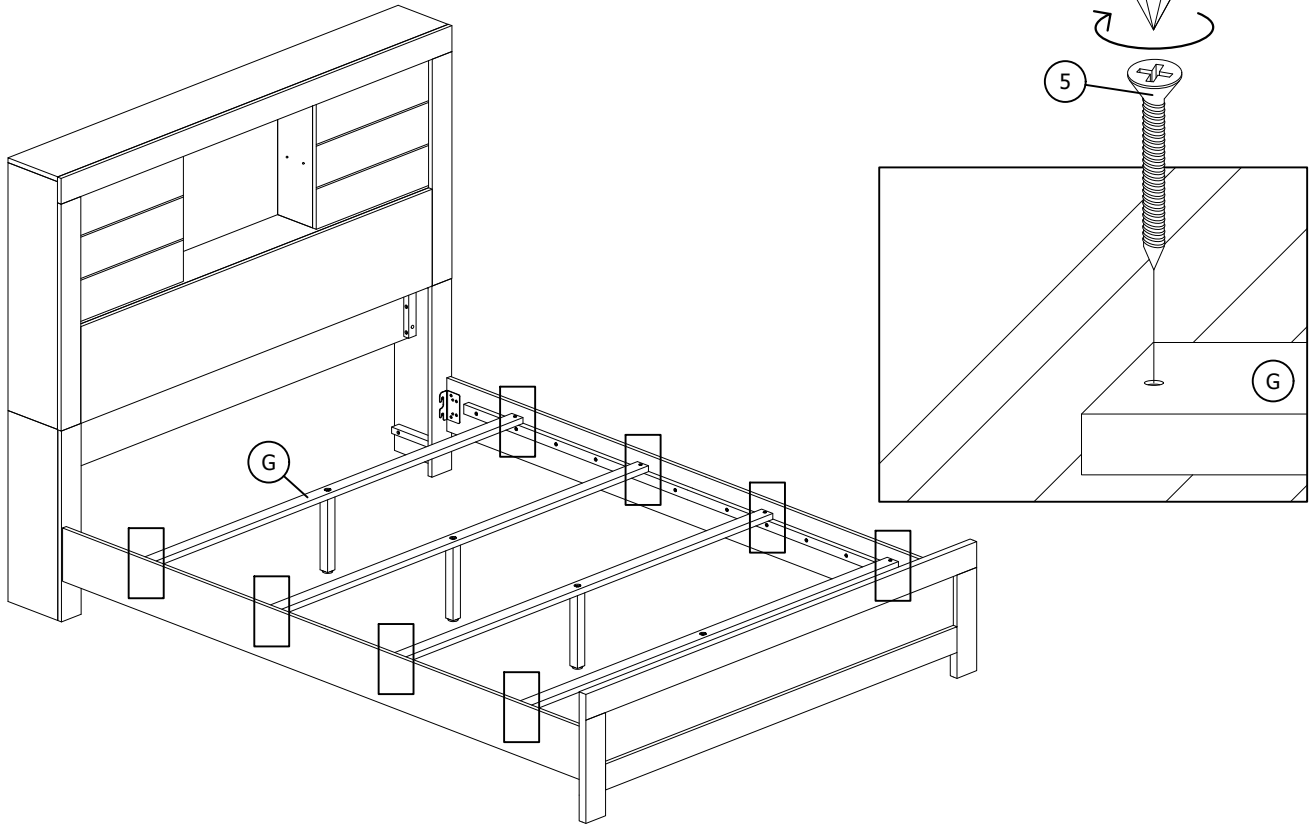

STEP 6

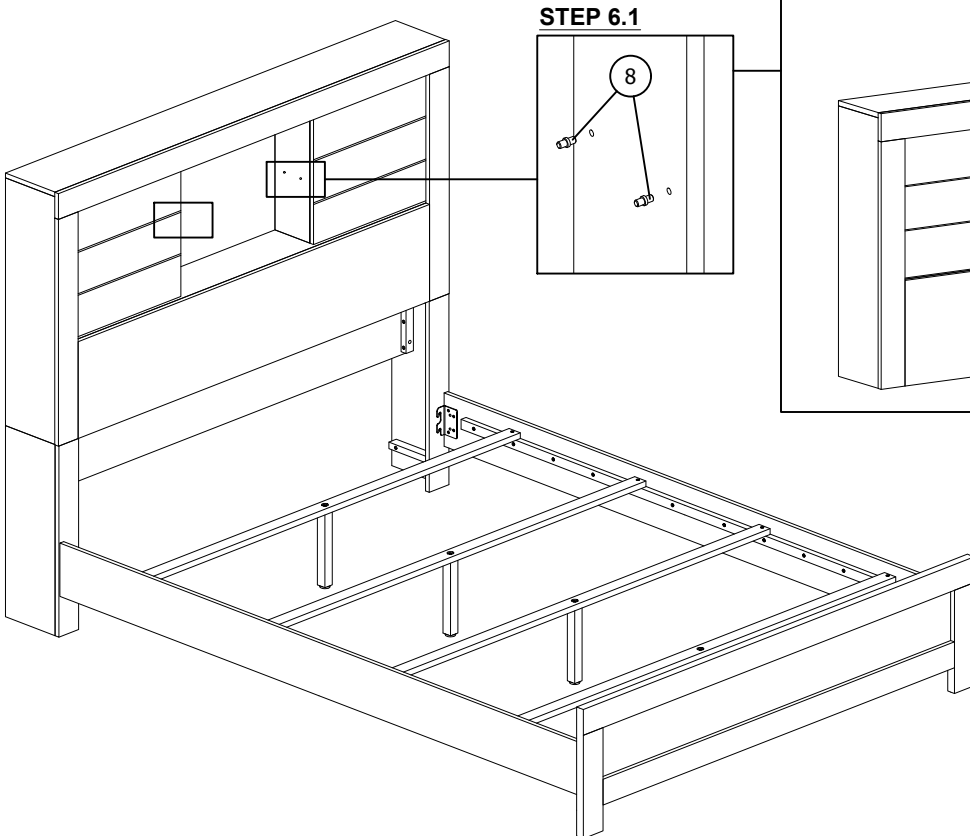

STEP 6.2

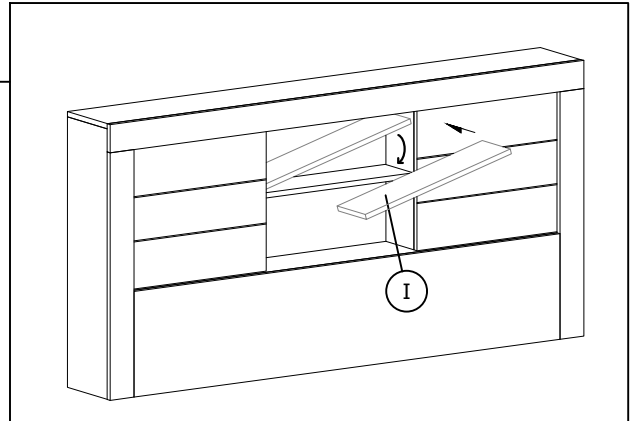

LISBON-GREY/BLACK-BOOKCASE FB/QB ASSEMBLY INSTRUCTION

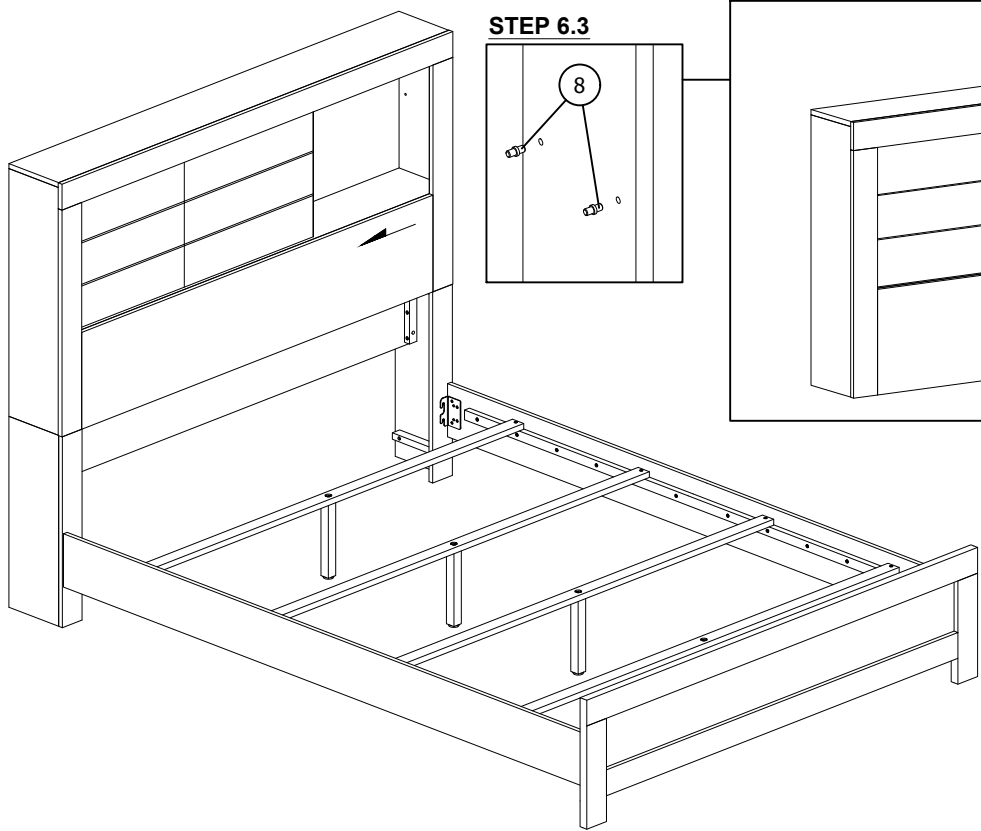

STEP 6.3

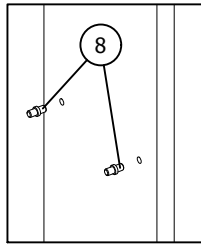

STEP 6.4

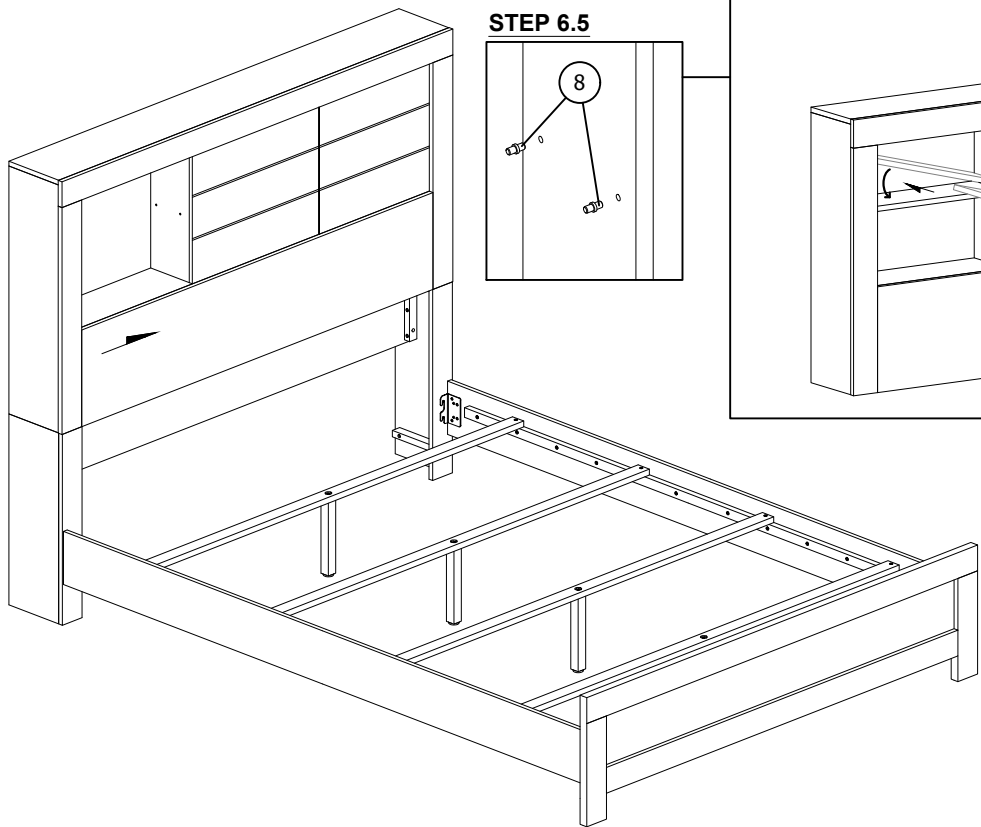
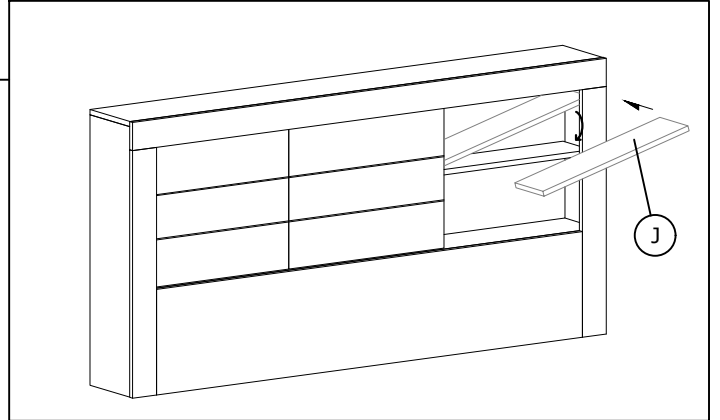

STEP 6.5

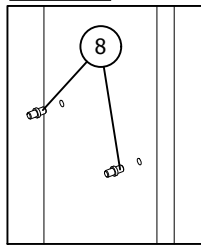

STEP 6.6

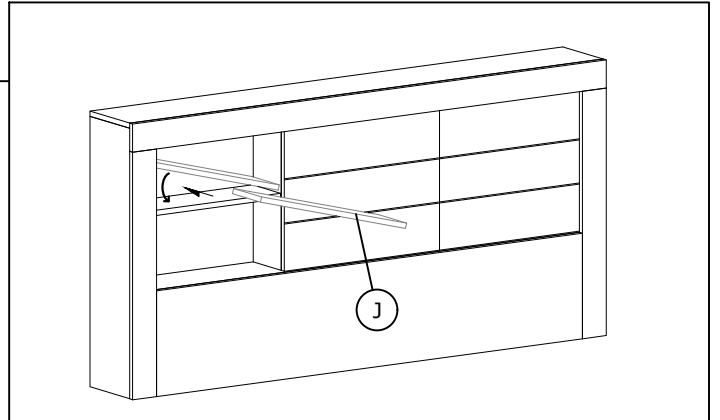

LISBON-GREY/BLACK-BOOKCASE FB/QB ASSEMBLY INSTRUCTION

STEP 7

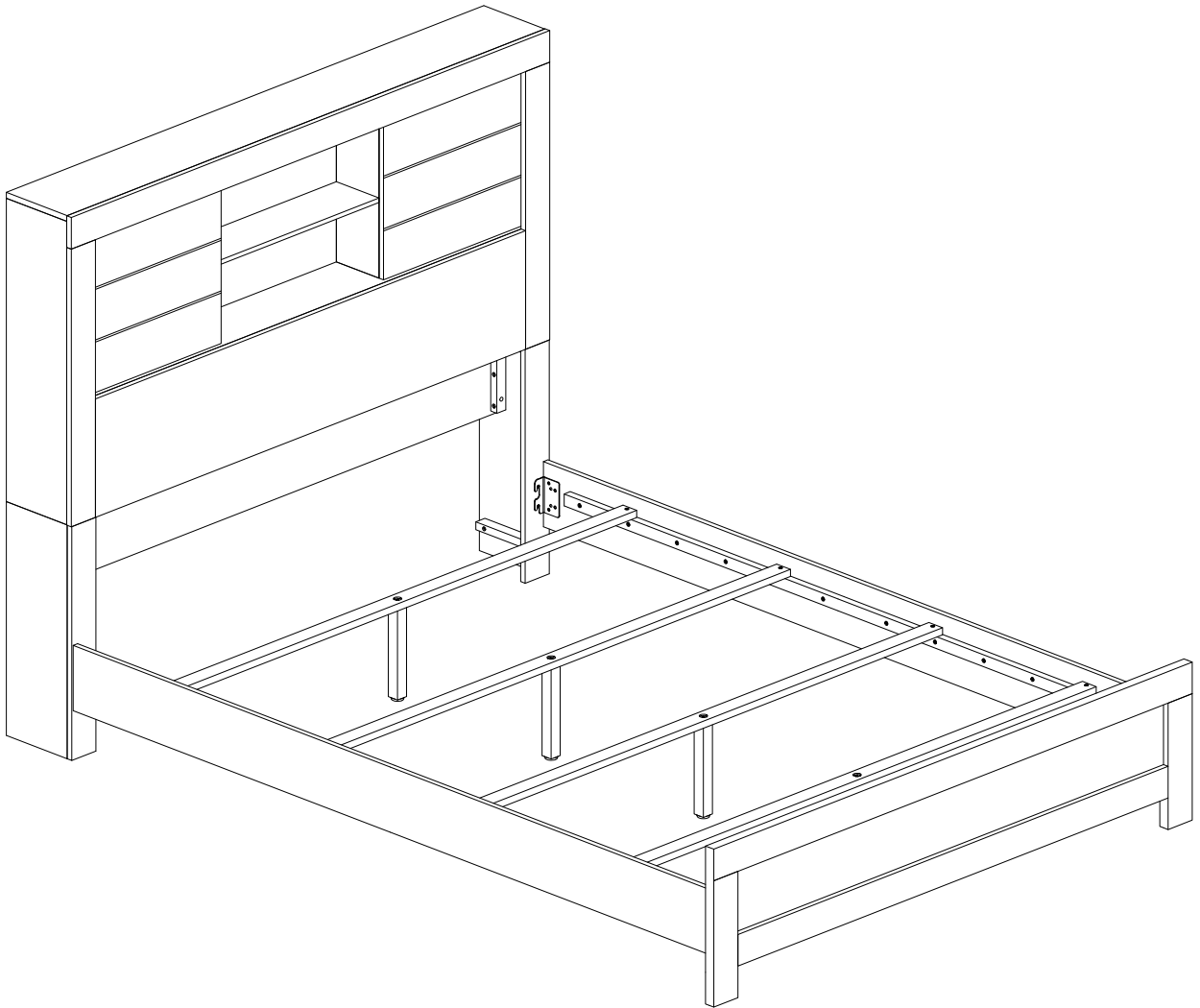

ASSEMBLY COMPLETED