

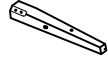

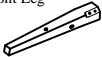





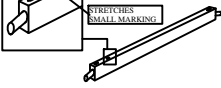
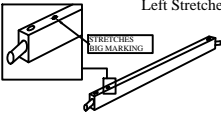

# ASSEMBLY INSTRUCTIONS

**MODEL : 9025A**  
**MONACO BAR STOOL CHAIR**

**PART LIST (X2)**

No	ITEM	Qty
A	Back Rest 	1 pc
B	Right Front Leg with small hole marking 	1 pc
C	Left Front Leg 	1 pc
D	Cushion Seat 	1 pc
E	Right Stretcher 	1 pc
F	Left Stretcher 	1 pc
G	Front Stretcher 	1 pc

**HARDWARE LIST (X2)**

No	ITEM	Qty
1	CSK SCREW M4 x 35MM 	6 pcs
2	JCBB BOLT M8 x 50MM 	4 pcs
3	JCBB BOLT M8 x 70MM 	4 pcs
4	JCBB BOLT M8 x 40MM 	2 pcs
5	SPRING WASHER M8 BLK 	10 pcs
6	FLAT WASHER M8 x 22 BLK 	10 pcs
7	ALLEN KEY M5 	1 pc

**STEP 1 :** Remove chair leg from the box seat (D) by open the bottom seat cover as shown.

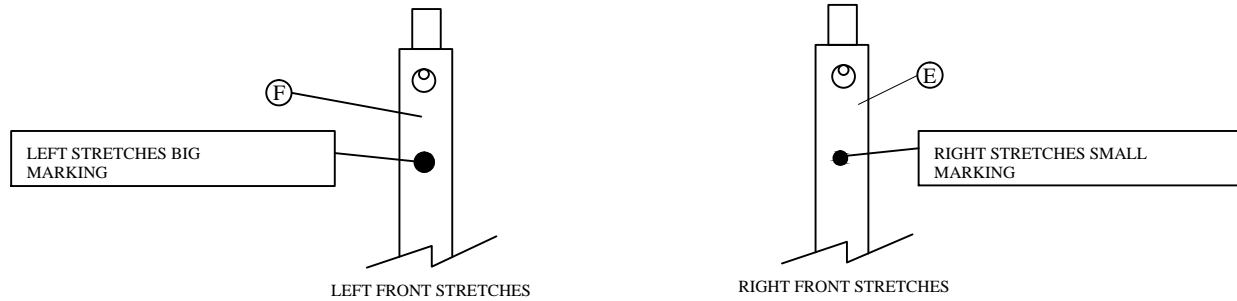

**STEP 2 :** Align the cushion seat (D) to the Back Rest (A) by secure with JCBB Bolt (3), Spring Washer (5) & flat washer (6) and tighten them with Allen Key (7) (DO NOT TIGHTEN BOLTS DURING THIS STEP)

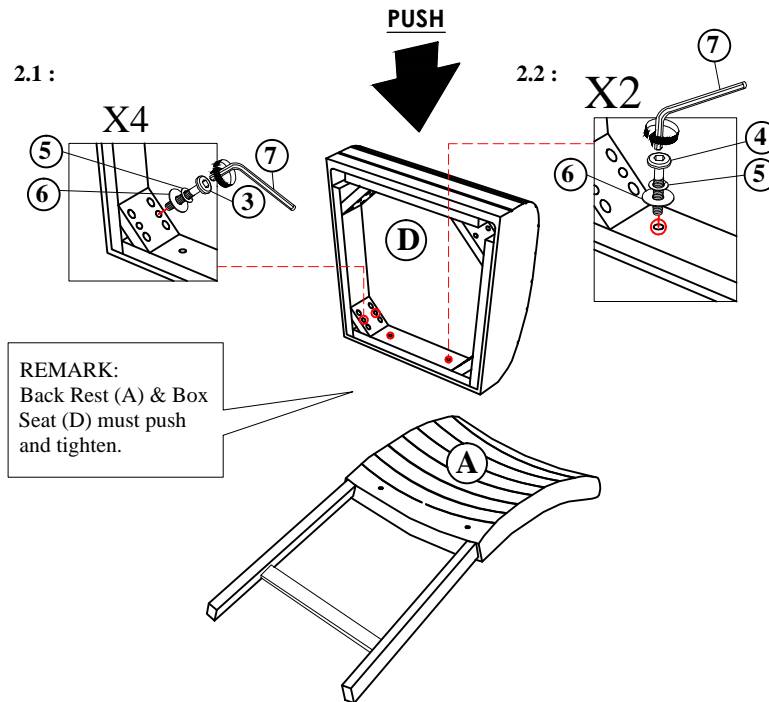

**STEP 3 :** Tighten the Right stretcher ( E ) and Left stretcher ( F ) with Csk Screw ( 1 ) and tighten with Screw Driver . ( Not Included )

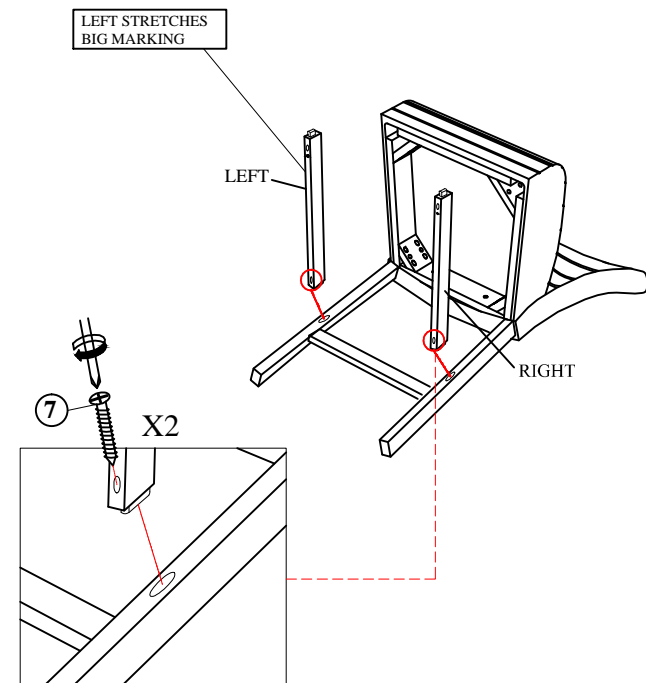

**STEP 4 : Fix Front Stretcher ( G ) to Front Leg Right ( B ) & Front Leg Left ( C ) with CSK Screw ( 1 ) and tighten with screw driver . ( Not Included )**

**STEP 5 : Tighten the Right stretcher ( E ) and Left stretcher ( F ) with Csk Screw ( 1 ) and tighten with Screw Driver . ( Not Included )**

( Reminder : Make sure all legs stable on the floor surface before FULLY TIGHTEN all the screw . )

**STEP 6 : Fix Front Leg ( B ) & ( C ) to Cusion Seat ( D ) and Secure With JCBC Bolt ( 2 ), Spring Washer ( 5 ) & Flat Washer ( 6 ) and tighten them with Allen Key ( 7 ) .**

( Reminder : Make sure all legs stable on the floor surface before FULLY TIGHTEN all the screw . )

STEP 4

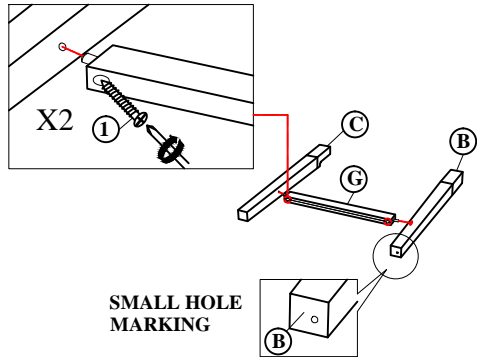

STEP 5

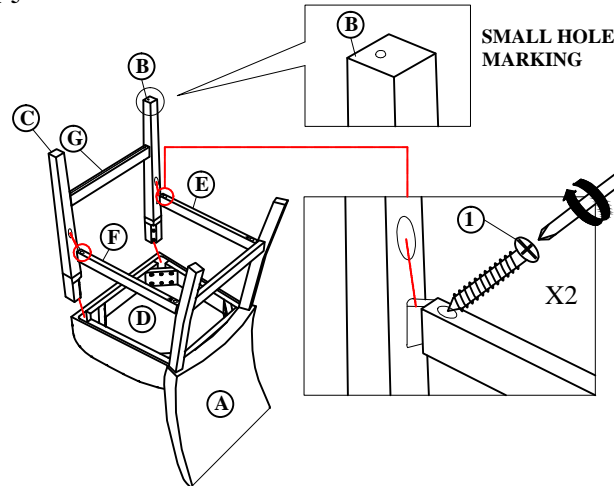

STEP 6

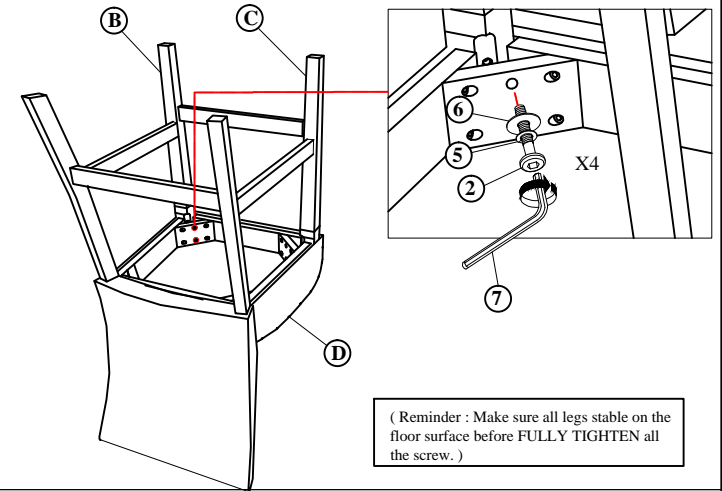

( Reminder : Make sure all legs stable on the floor surface before FULLY TIGHTEN all the screw . )

**STEP 7 : Closed down the cover of bottom cusion seat ( C ) after all parts completely fixed.**

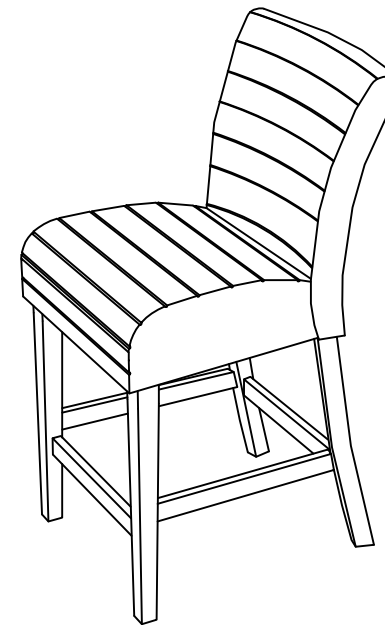
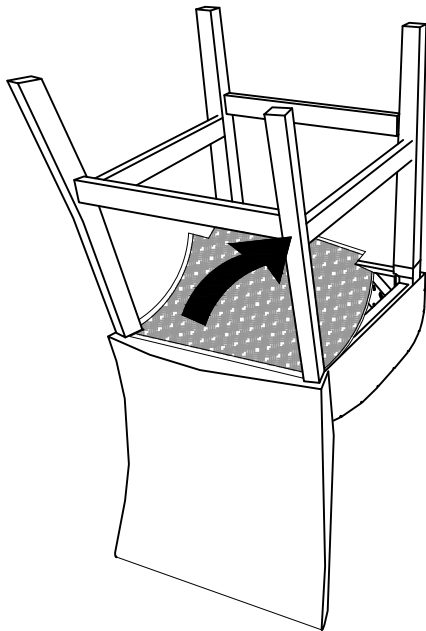

COMPLETE ASSEMBLY

NOTE : MUST TIGHTEN SCREWS PERIODCALLY WITH USE SCREW WILL BECOME LOOSE CHECK TIGHTNESS OF ALL SCREW EVERY 6-8 WEEKS.

PAGE 2 OF 2

# ASSEMBLY INSTRUCTIONS

**MODEL : 8031A  
MONACO BAR TABLE**

**(BOX 1)  
BOX OF DINING TABLE**

NO	ITEM	QTY
A	TABLE TOP	1 PC
B	CENTER PANEL	1 PC
C	TABLE BOTTOM	1 PC
D	TABLE LEG	1PC

**(BOX 1)  
HARDWARE LIST**

No	ITEM	Qty
1	Allen Key M4 X 65mm	1 pcs
2	JCBC Bolt m6x25mm Blk	4 pcs
3	JCBC Bolt m6x35mm	8 pcs
4	Spring Washer 1/4" Blk	12 pcs
5	Flat Washer 1/4"Dx19mmOD Blk	4 pc
6	Flat Washer 1/4"Dx13mmOD Blk	8 pc

**STEP 1 :** Place the Table Bottom (C) on the Table Leg (D), fasten it the JCBC Bolt (3) together with Spring Washer (4) & Flat Washer (5) use an Allen Key (1) until it's tight.

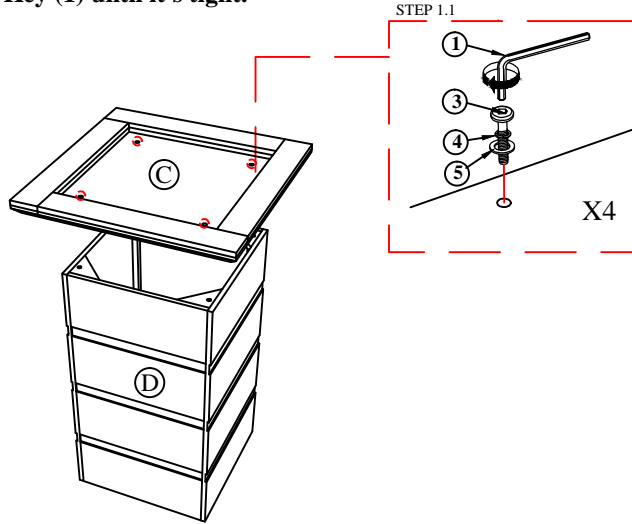

**STEP 2 :** Turn it upside down and place the Center Panel (B) on the Table Leg (D), fasten it the JCBC Bolts (3) together with Spring Washers (4) & Flat Washers (6) using an Allen Key (1) until tight.

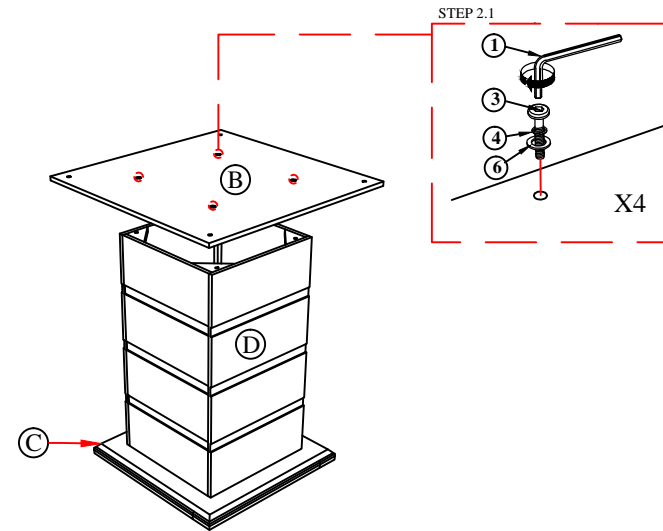

**STEP 3 :** Place the Table Top (A) upside down on a soft surface, then turn the Table Leg upside down and place it under the Table Top (A) as shown below. fasten the screw JCBC Bolt (2) together with Spring Washer (4) & Flat Washer (6). Fasten until tight.

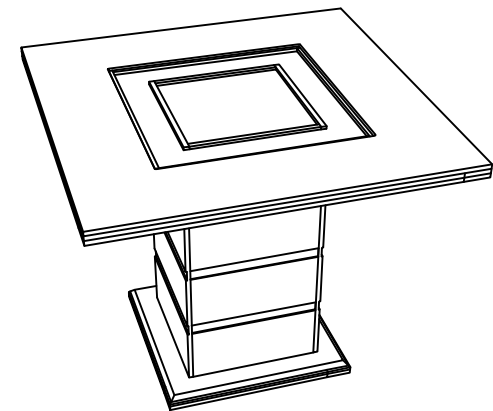
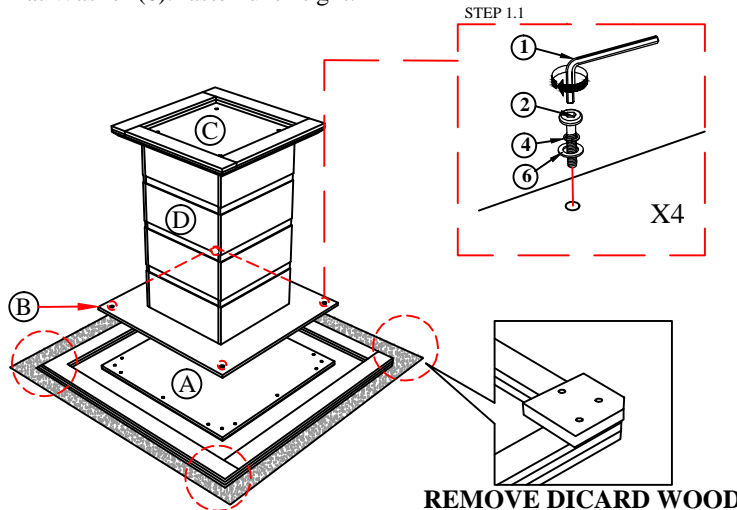

***COMPLETED ASSEMBLY***