

STEP 4 : Fix Front Stretcher (G) to Front Leg Right (B) & Front Leg Left (C) with CSK Screw (1) and tighten with screw driver . (Not Included)

STEP 5 : Tighten the Right stretcher (E) and Left stretcher (F) with Csk Screw (1) and tighten with Screw Driver . (Not Included)

(Reminder : Make sure all legs stable on the floor surface before FULLY TIGHTEN all the screw .)

STEP 6 : Fix Front Leg (B) & (C) to Cusion Seat (D) and Secure With JCBC Bolt (2), Spring Washer (5) & Flat Washer (6) and tighten them with Allen Key (7) .

(Reminder : Make sure all legs stable on the floor surface before FULLY TIGHTEN all the screw .)

STEP 4

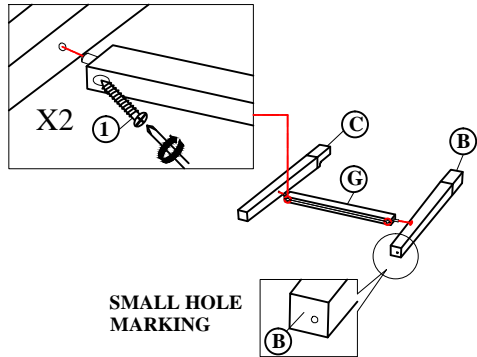

STEP 5

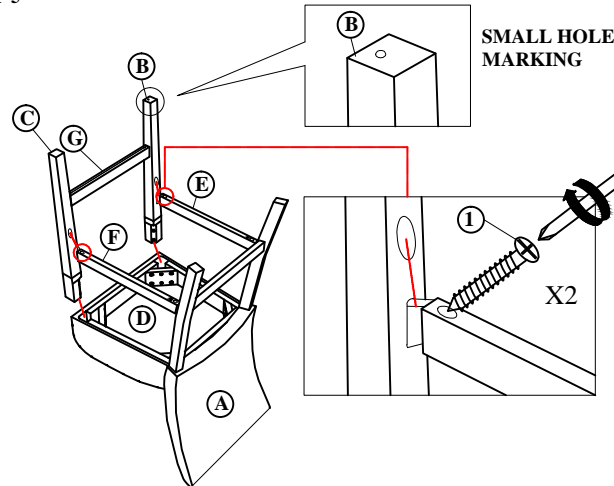

STEP 6

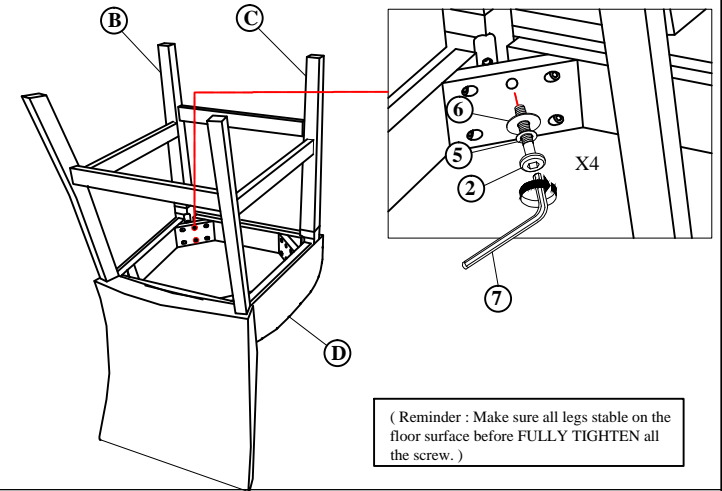

(Reminder : Make sure all legs stable on the floor surface before FULLY TIGHTEN all the screw .)

STEP 7 : Closed down the cover of bottom cusion seat (C) after all parts completely fixed.

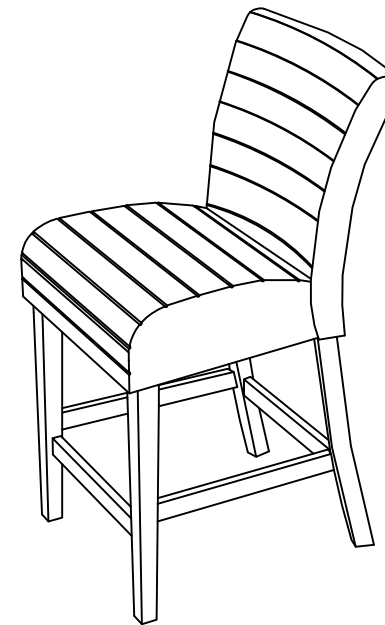
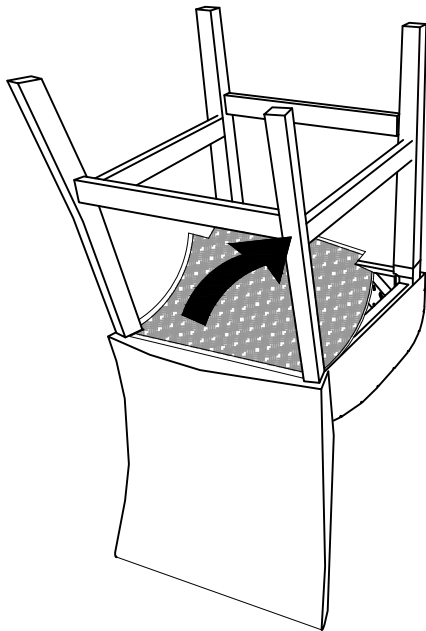

COMPLETE ASSEMBLY

NOTE : MUST TIGHTEN SCREWS PERIODCALLY WITH USE SCREW WILL BECOME LOOSE CHECK TIGHTNESS OF ALL SCREW EVERY 6-8 WEEKS.

PAGE 2 OF 2