

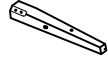

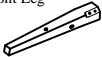





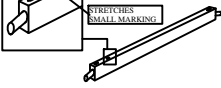
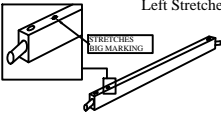

ASSEMBLY INSTRUCTIONS

MODEL : 9025A
MONACO BAR STOOL CHAIR

PART LIST (X2)

No	ITEM	Qty
A	Back Rest 	1 pc
B	Right Front Leg with small hole marking 	1 pc
C	Left Front Leg 	1 pc
D	Cushion Seat 	1 pc
E	Right Stretcher 	1 pc
F	Left Stretcher 	1 pc
G	Front Stretcher 	1 pc

HARDWARE LIST (X2)

No	ITEM	Qty
1	CSK SCREW M4 x 35MM 	6 pcs
2	JCBB BOLT M8 x 50MM 	4 pcs
3	JCBB BOLT M8 x 70MM 	4 pcs
4	JCBB BOLT M8 x 40MM 	2 pcs
5	SPRING WASHER M8 BLK 	10 pcs
6	FLAT WASHER M8 x 22 BLK 	10 pcs
7	ALLEN KEY M5 	1 pc

STEP 1 : Remove chair leg from the box seat (D) by open the bottom seat cover as shown.

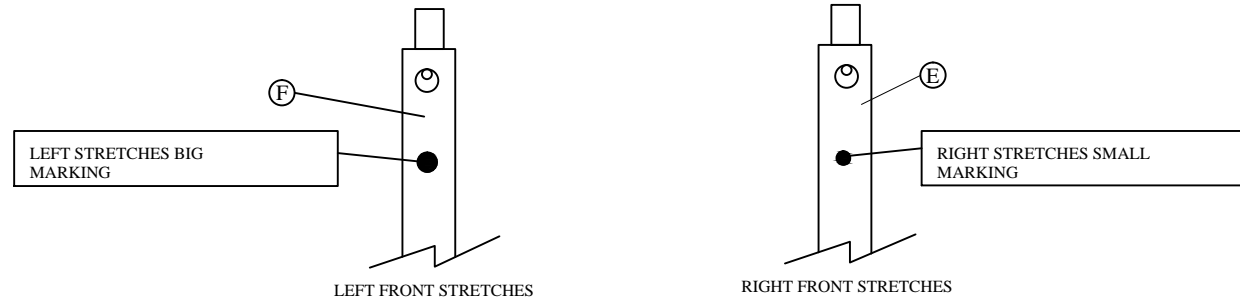

STEP 2 : Align the cushion seat (D) to the Back Rest (A) by secure with JCBB Bolt (3), Spring Washer (5) & flat washer (6) and tighten them with Allen Key (7) (DO NOT TIGHTEN BOLTS DURING THIS STEP)

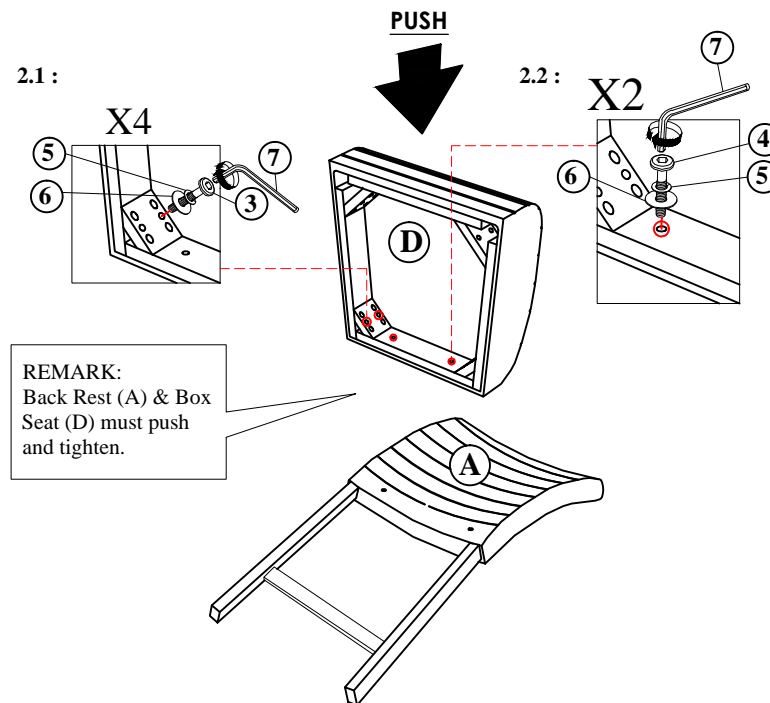

STEP 3 : Tighten the Right stretcher (E) and Left stretcher (F) with Csk Screw (1) and tighten with Screw Driver . (Not Included)

