

MODEL RTA-3520

ASSEMBLY INSTRUCTIONS

Thank you for purchasing our product.

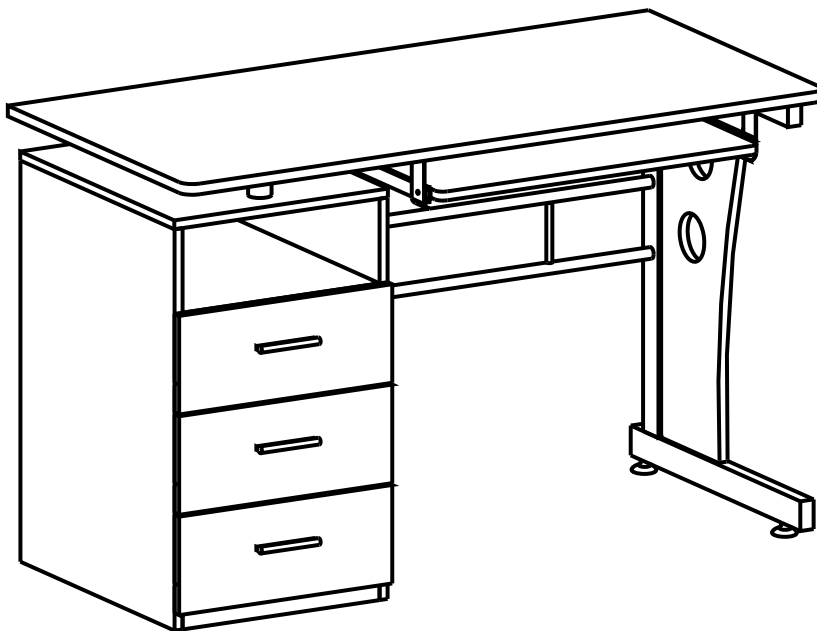

REV.LS-6541-0322-4





- Please read carefully the assembly instructions before the installation.



- Do not discard this manual or any of the packaging material until the unit has been completely assembled.



- Might require two people.











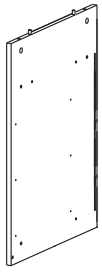
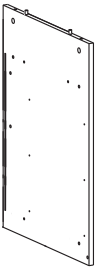

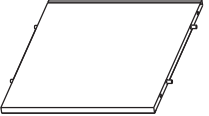
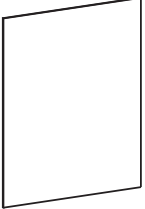

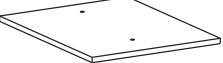

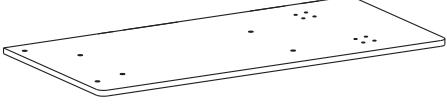
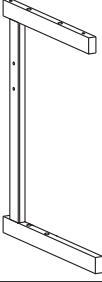
SAMPLE - DO NOT SCAN

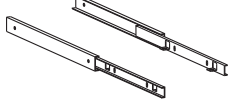

- We have added QR Codes to some steps for your assistance. If a QR Code is provided on a step, scan it to view the assembly video online.

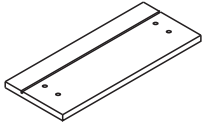
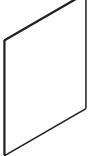
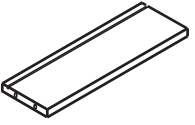
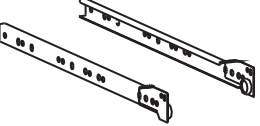
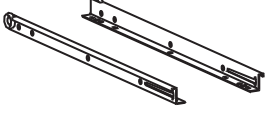



MAIN PARTS LIST

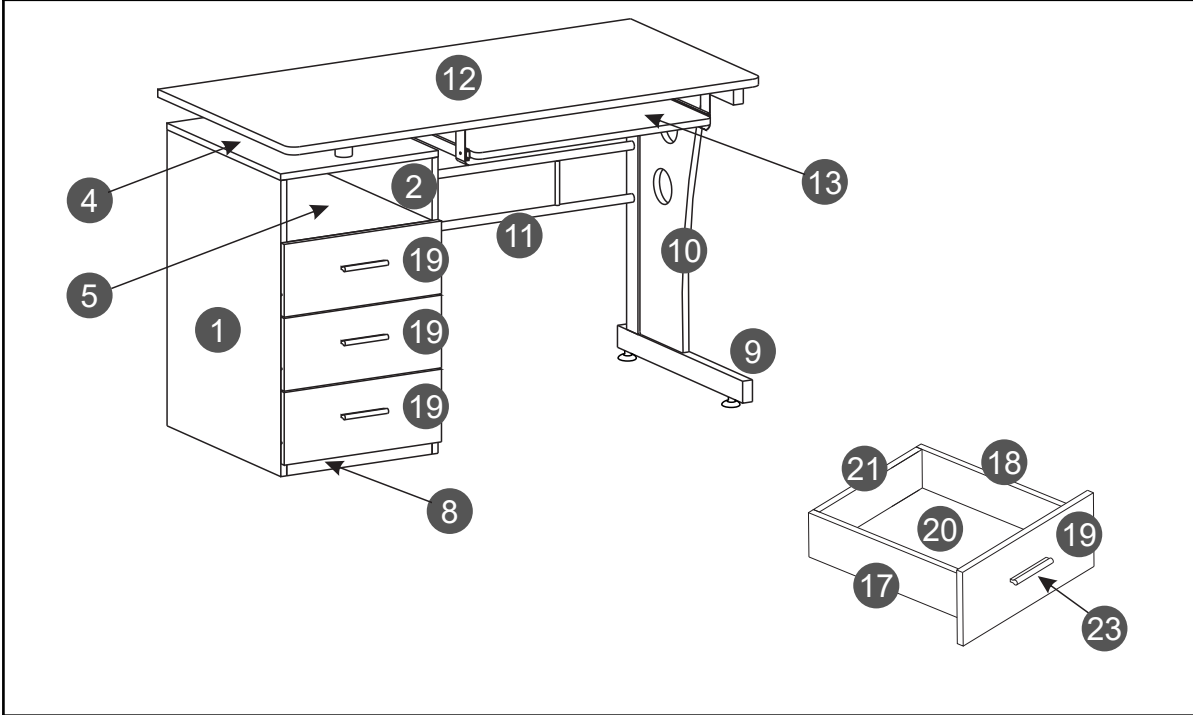

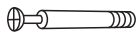

| | | | | | | | | | |
|-----------------|--|----------------|---|---------------------|---|-----------------|--|-----------------|--|
| 1 x1 | Left panel  | 2 x1 | Middle panel  | 3 x2 | Glide studs  | 5 x1 | Cabinet shelf panel  | 6 x1 | Bottom panel  |
| 7 x1 | Back panel  | 8 x1 | Bottom skirt panel  | 4 x1 | Cabinet top panel  | 10 x1 | Right panel  | 11 x1 | Back metal structure  |
| 12 x1 | Desktop  | | | 9 x1 | Right metal leg  | 14 x4 | Slider base bracket  | 15 x1 | Keyboard sliders, SET of 1 right and 1 left  |
| 13 x1 | Keyboard panel  | | | 16 x2 | Support tube  | 17 x3 | Drawer left panel  | 18 x3 | Drawer right panel  |
| 19 x3 | Drawer front panel  | | | 20 x3 | Drawer bottom panel  | | | | |
| 21 x3 | Drawer back panel  | | | 22 3 sets | Drawer sliders, SET of 4 pcs for each drawer: <ul style="list-style-type: none"> • 2 "Flat", right and left for inside the cabinet • 2 "L" shaped, right and left for the drawers   <p style="text-align: center; margin-top: 5px;">"Flat": go inside the cabinet "L" shape: go on drawers</p> | | | | |
| 23 x3 | Handle  | | | | | | | | |

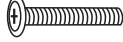
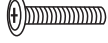
MAIN PARTS LAYOUT (FOR REFERENCE):

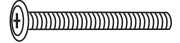

LIST OF HARDWARE, SCREWS AND FITTINGS

| PART | QTY | ITEM | |
|------|-----|-------|---|
| A | 24 | M3x15 |  |
| B | 26 | M6x40 |  |
| C | 4 | M6x75 |  |
| D | 4 | M6x35 |  |
| E | 2 | M6x25 |  |
| F | 4 | M6x12 |  |
| G | 4 | M4x4 |  |

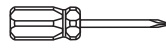
| PART | QTY | ITEM | |
|------|-----|----------------------|---|
| H | 12 | M4x14 |  |
| I | 2 | M6x60 |  |
| J | 12 | M4x35 |  |
| K | 6 | M4x20 |  |
| L | 2 | Ø40mm Plastic washer |  |
| | 1 | Screwdriver |  |

▣ This unit uses cam bolts and locks. The following explains how to use them. This is not an assembly step; it is a guide for when you are actually doing the assembly using this kind of hardware.

Cam Lock



Cam Bolt

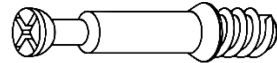

1. Screw the bolt into the corresponding hole on panel "A".

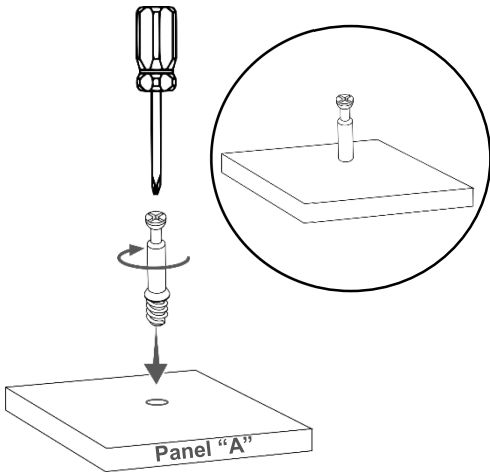

2. Join panel "B" to panel "A". If panel "B" comes with the cam lock pre-installed, make sure it is aligned to receive the bolt's head (refer to point 3). There might be a very small gap between the panels which is normal.

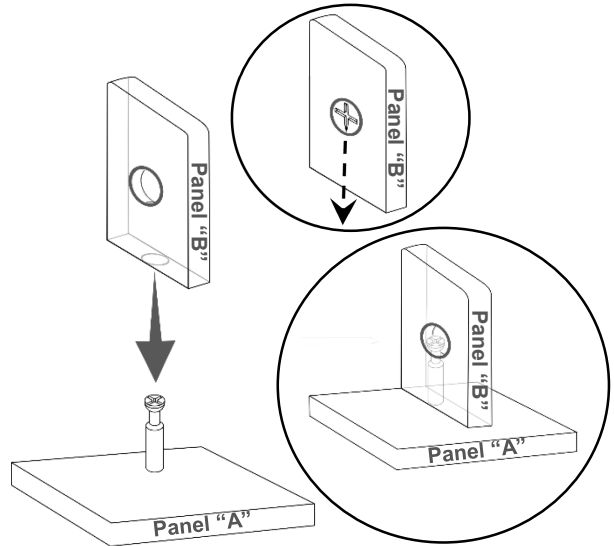

3. Insert the cam lock on panel "B" making sure it goes aligned to receive the bolt's head.

Alignment: The cross points towards the panel "A" with the bolt.

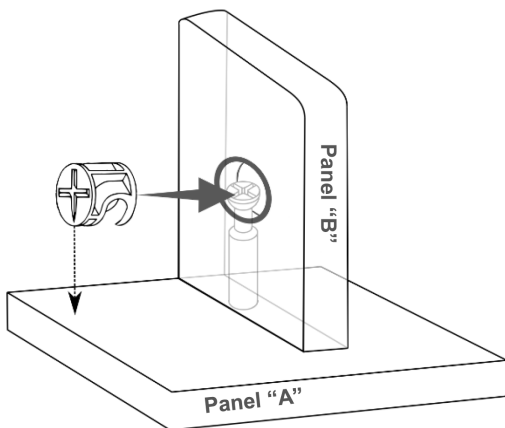

4. Turn the cam lock clockwise. This will lock the parts together and will close any gaps.

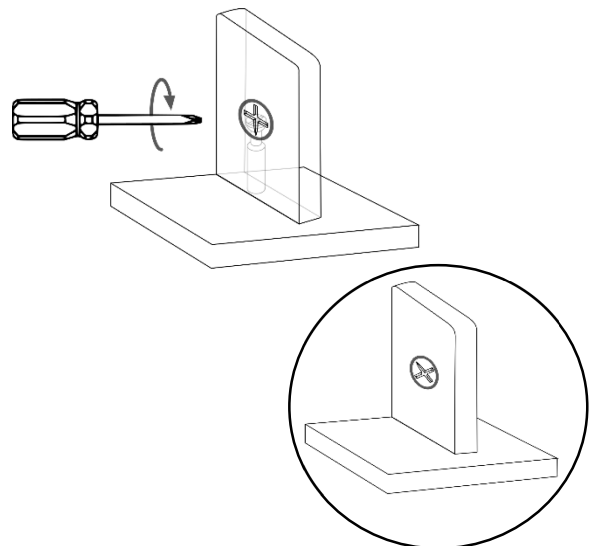

BEFORE YOU START THE ASSEMBLY, PLEASE READ THE FOLLOWING TIPS AND WARNINGS.

1 Do a quick inventory to make sure the package contains all the parts and hardware listed in the assembly instructions.



7 To avoid misalignments, always leave the screws loose and tighten them until all pieces are positioned correctly.

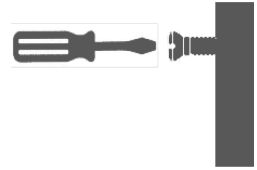

2 Missing, damaged and defective parts can be replaced at no cost to you. Please refer to the last pages on this manual.



8 Do not overtighten or force the screws as they might break, strip, damage the threads of the holes or get stuck inside the part.

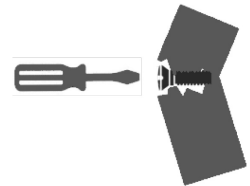

3 The replacement parts service is limited to the 48 contiguous United States. If you reside in Alaska, Hawaii, Puerto Rico, U.S. territories or other countries, please contact the supplier from where the unit was purchased.



9 Sometimes the laminate might cover partially or entirely the hole on a panel. If there is no visible hole for the screw, pass and press the tip of your finger over the area where the hole should be located to feel the indentation, and once found, carefully pierce the laminate to reveal the hole underneath.



4 If during assembly you find an issue or need clarification, please contact our Customer Service for assistance. Please refer to the last pages on this manual.



5 On each step read the instructions and analyze the illustrations thoroughly before proceeding to do the assembly.



10 If the hole seems too small for the screw, first make sure you are using the correct size of screw and that it's been installed in the correct hole. If the hole still appears to be too small, carefully pierce the laminate to reveal the hole's actual size.



6 Make sure you understand which hardware will be used on each step. Using the wrong size of screw, bolt or pin might strip the threads or cause damage to the part in which it is being used.

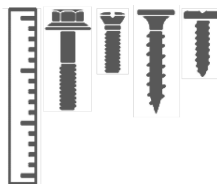

ASSEMBLY STEPS

STEP 1

Grab all the sets of drawer sliders **22** (total 12 pcs) and separate them into 2 groups according to their shape:

- The "Flat" ones will be used on the next step.
- The "L Shaped" will be used until step **19**, set them aside.

22 ("Flat" Right, x3)

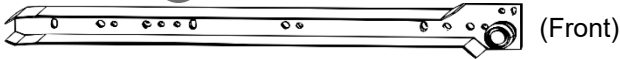

22 ("Flat" Left, x3)

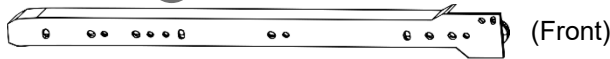

The "Flat" ones will be used on step **2**.

22 ("L" Right, x3)

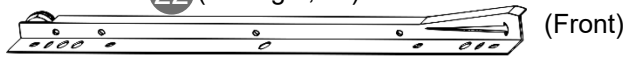

22 ("L" Left, x3)

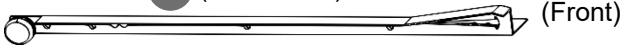

The "L-Shaped" will be used on step **19**, set them aside.

STEP 2

Hardware:

A



M3x15

12 Pcs

Assemble the "Flat" sliders **22** to the side panels **1** and **2** with screws **A**. Please note:

- The sliders attach at the front on the 3th hole.
- The wheel is at the front, and faces down with 2 empty holes above the wheel.

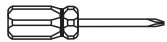

Scan QR Code to view video

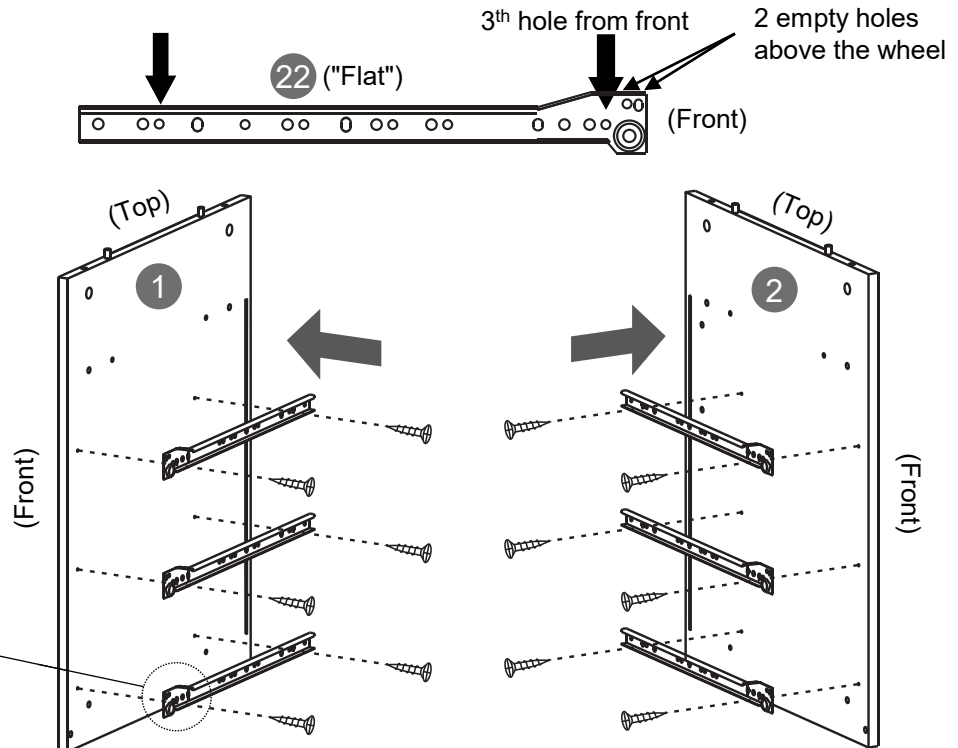

STEP 3

Hardware:

B

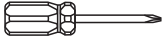
M6x40
Bolt5
Pcs

- Attach the bolts **B** to panel **1** into the indicated holes.
- Assemble the shelf **5** to panel **1** at the top as explained in page **5**. Note that the surface with the groove faces towards the bottom. The groove will be located at the back.
- Join panel **8** to panel **6**, then assemble both panels to panel **1** at the bottom as explained in page **5**. Note that on **6** the surface with the groove faces towards the top.

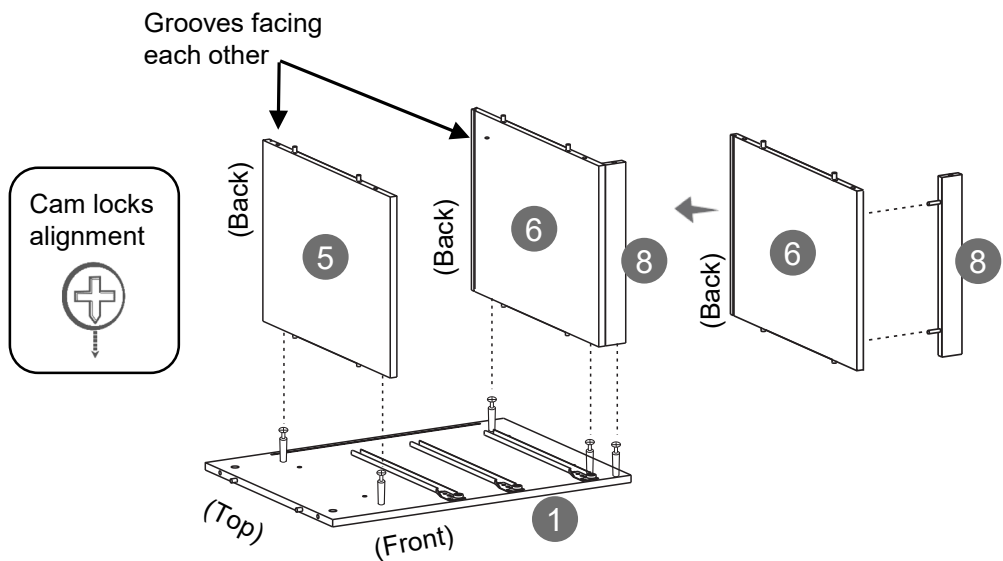
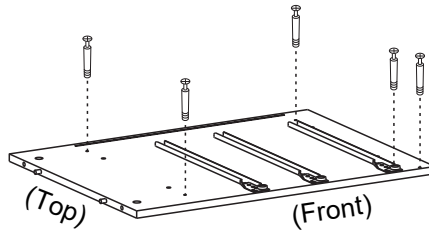

STEP 4

Slide the back panel **7** through the grooves of panels **5** and **6**, and into the groove of panel **1**.

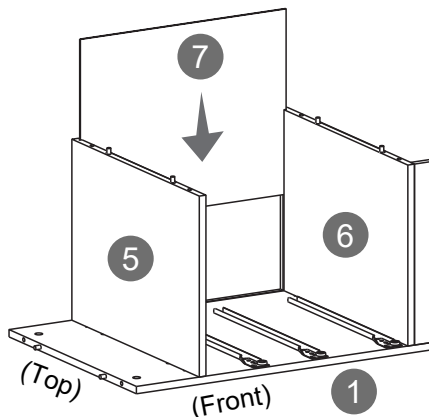

STEP 5

Hardware:

B



M6x40 Bolt

5 Pcs

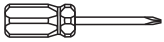

- Attach the bolts **B** to panel **2** into the indicated holes.
- Assemble panel **2** to panels **5**, **6** and **8** as explained in page **5**.

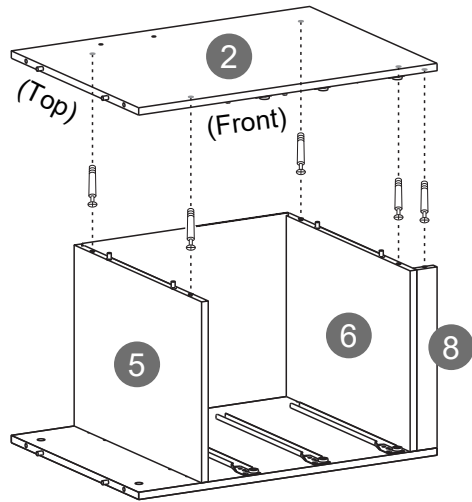
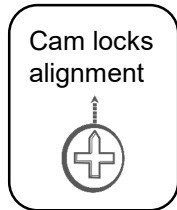
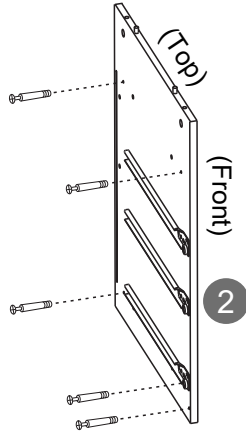

STEP 6

Hardware:

B



M6x40 Bolt

4 Pcs

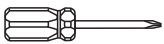

- Bring the cabinet upright.
- Attach the bolts **B** to the bottom surface of panel **4**.
- Assemble panel **4** to panels **1** and **2** as explained in page **5**.

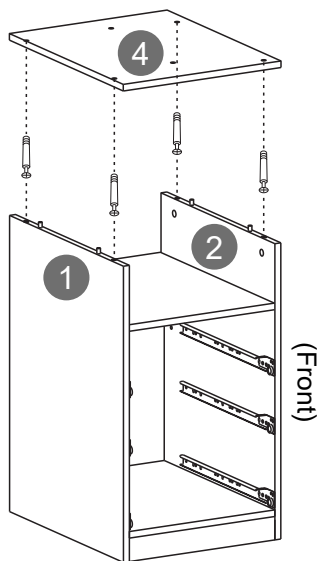
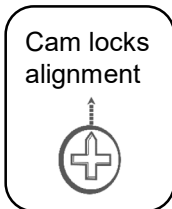

STEP 7

Hardware:

| | | |
|----------|---|-----|
| C |  | 4 |
| | M6x75 | Pcs |

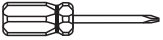

Scan QR Code to view video

- On the right panel **10**, check and make sure the inserts are aligned to receive the screws: The groove on the inserts must run vertically. If the insert are crooked, use a flat head screwdriver to align them.
- Assemble panel **10** to the metal leg **9** with screws **C** from above and underneath as shown.

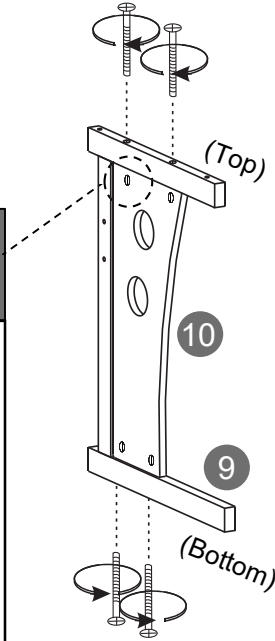

If the inserts on the panel are crooked, the screws won't go in; turn them with a screwdriver to re-align them.

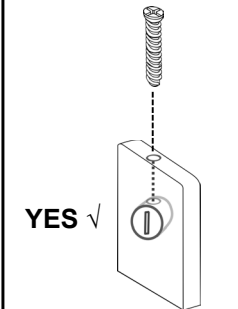
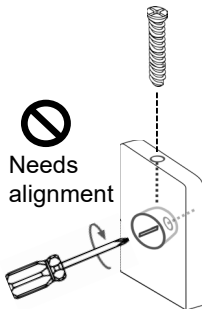

STEP 8

Screw the glide studs **3** into the bottom holes of the leg **9**.

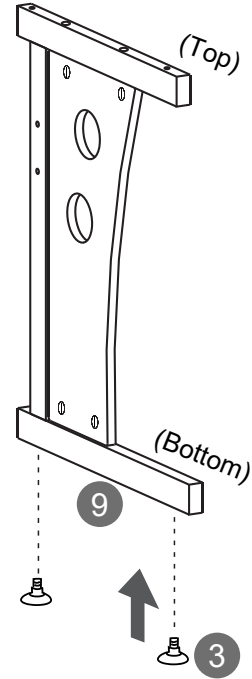

STEP 9

Hardware:

| | | |
|----------|---|-----|
| D |  | 2 |
| | M6x35 | Pcs |

| | | |
|----------|---|-----|
| E |  | 2 |
| | M6x25 | Pcs |

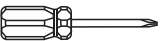

- Assemble the back structure **11** to the middle panel **2** with screws **E** from inside the cabinet.
- Assemble the leg **9** to the back structure **11** with screws **D**.

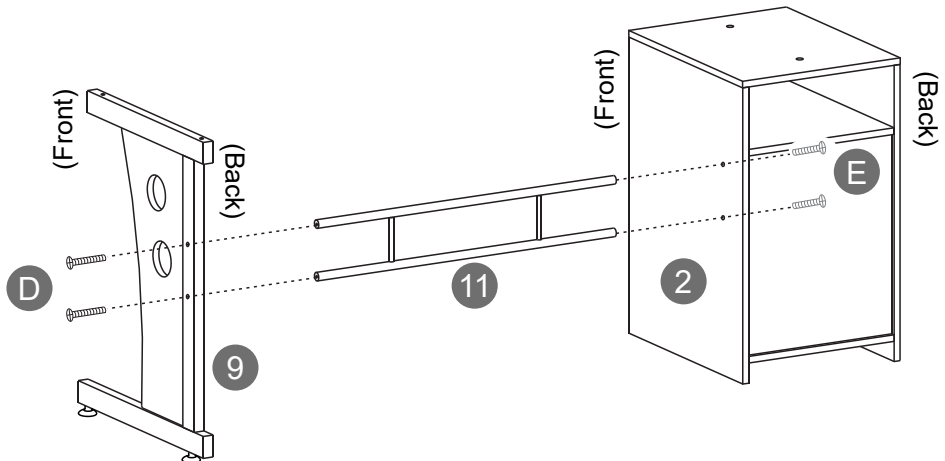

STEP 10

Hardware:

F

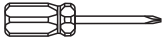
4
Pcs

Place the tabletop **12** upside-down and attach the brackets **14** with screws **F** making sure they face towards the inside.

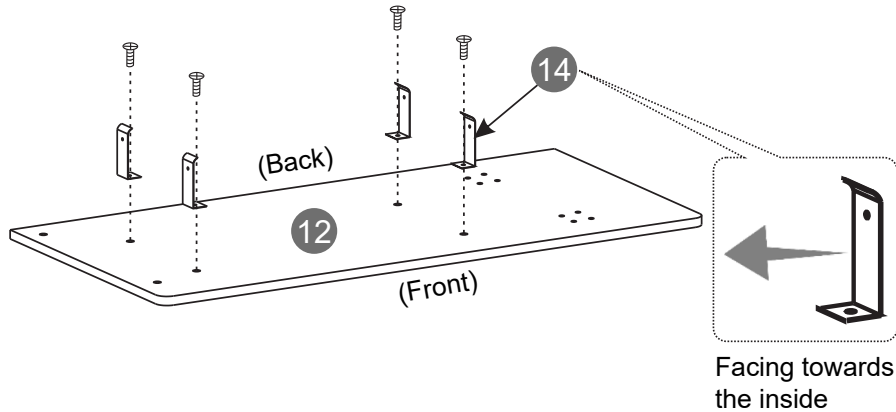

STEP 11

Hardware:

G

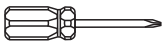
4
Pcs

Attach the keyboard sliders **15** to the brackets **14** with screws **G**.

Notes:

- The tabs on the sliders will face **UP**.
- The screws are the exact size, and will go from the outside through the brackets and will reach into the threaded holes of the sliders.

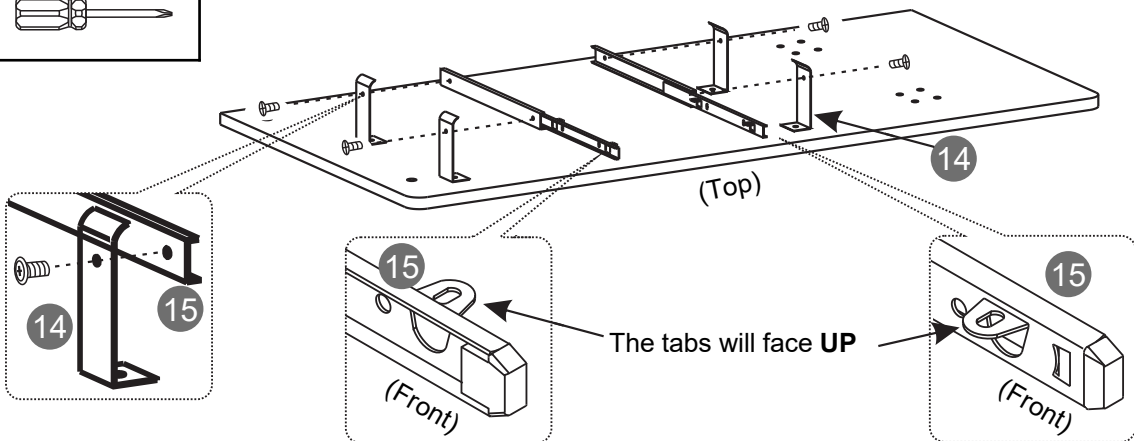

STEP 12

Hardware:

H

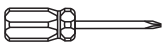

8
Pcs

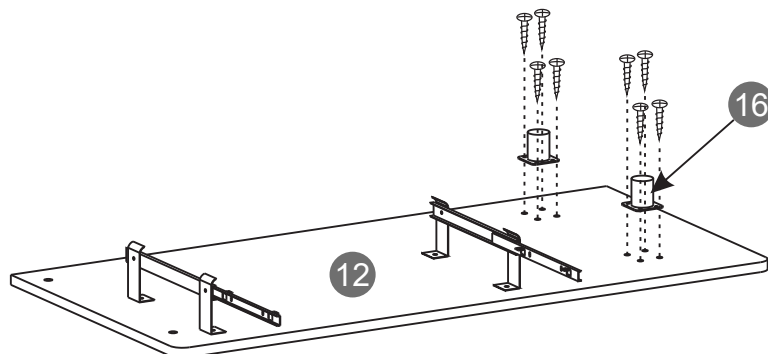
Assemble the support tubes **16** to the tabletop **12** with screws **H**.



STEP 13

Hardware:

| | | |
|----------|---|----------|
| D |  | 2 Pcs |
| I |  | 2 Pcs |
| L |  | 2 Pcs |

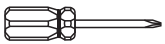

- Place the plastic washers **L** over the holes on the cabinet top panel **4**.
- With the help of another person, place the tabletop **12** over the cabinet and leg, making the holes from the tubes **16** coincide with the holes on panel **4** and the washers **L**.
- Assemble the tabletop **12** with screws **D** from underneath. The screws go through panel **4** and the washers, and into the threaded holes of the tubes **16**.
- Assemble the tabletop **12** to the leg **9** with screws **I** from underneath.

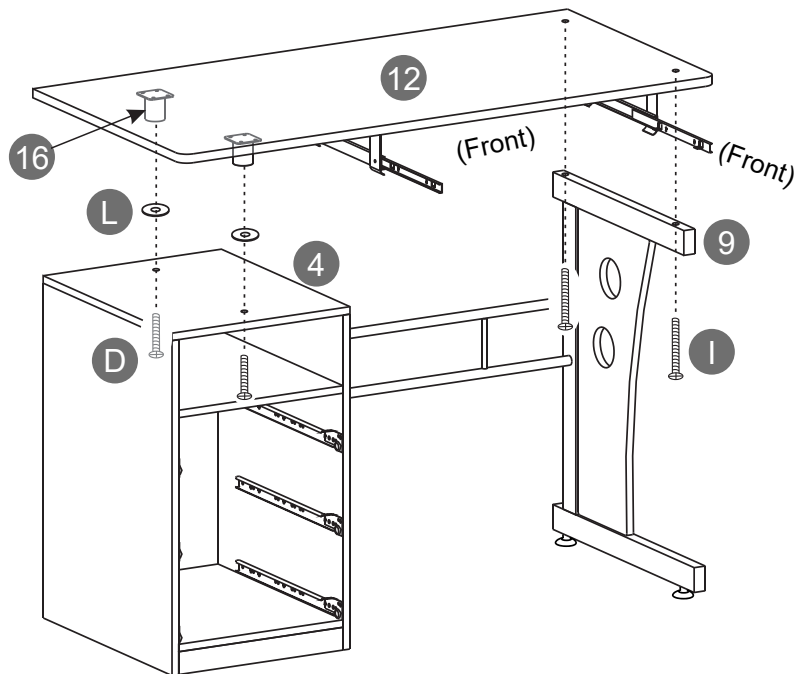

STEP 14

Hardware:

| | | |
|----------|---|----------|
| H |  | 4 Pcs |
|----------|---|----------|

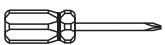

- Pull out the sliders **15** and place the keyboard panel **13** over its tabs making sure the pre-drilled holes coincide with the hole on the tabs, then attach the panel with screws **H** from underneath.

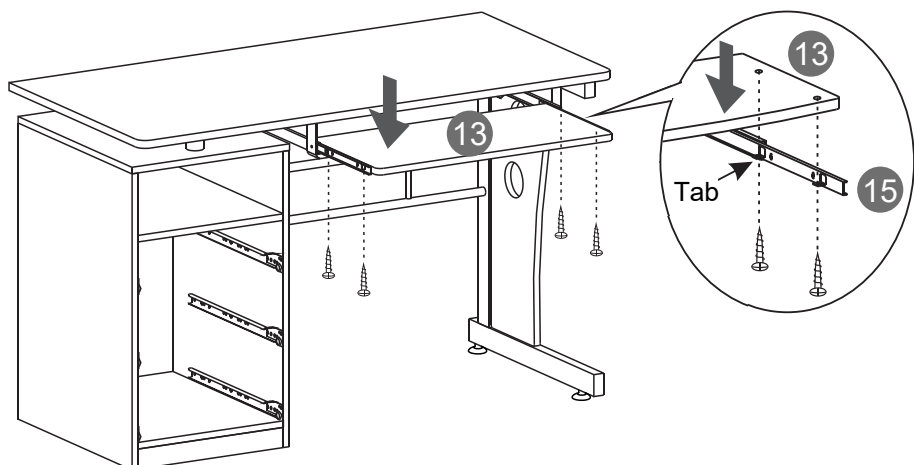

STEP 15

Hardware:

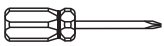
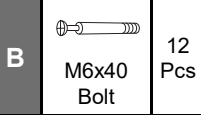

Cam locks
alignment



For each of the 3 drawers, assemble the side panels **17** and **18** to the front panel **19** with bolts **B** as explained in page 4.

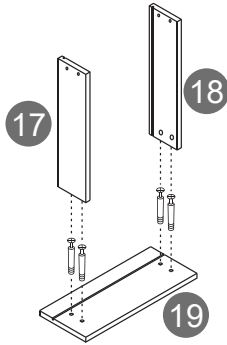

STEP 16

For each of the 3 drawers, slide the bottom panel **20** through the grooves of the side panels and into the front panel as shown.

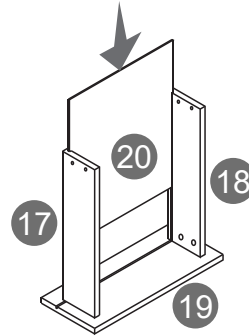

STEP 17

Hardware:

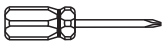

For each of the 3 drawers, assemble the back panel **21** to the side panels **17** and **18** with screws **J**.

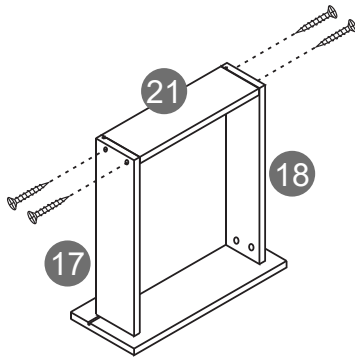

STEP 18

Hardware:

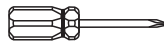

For each of the 3 drawers, assemble the handle **23** to the front panel **19** with screws **K**.

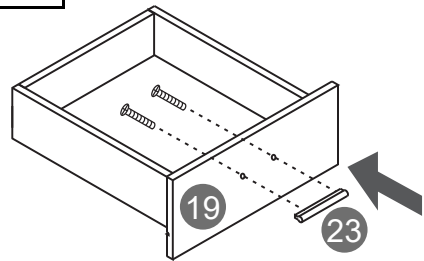

STEP 19

Hardware:

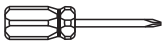

For each of the 3 drawers, flip them upside-down and assemble the "L" sliders **22** with screws **A**, making sure the wheel goes towards the back, and that they don't protrude, otherwise, the drawer raises 1" and won't fit in the cabinet.

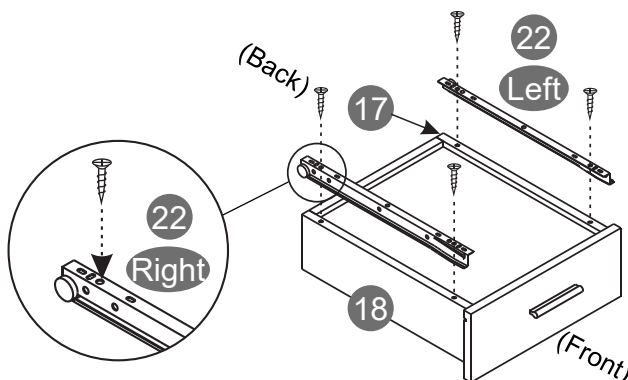

When finished, the sliders should look like this from the back of the drawer:

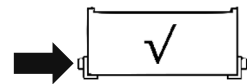

The assembly below is incorrect, it raises 1" and the drawer won't fit:

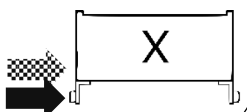

Scan QR Code
to view video

STEP 20

- Insert the drawers into the cabinet, starting with the bottom one, then the middle, then the top one. Insert at an angle with their fronts facing down, making sure the wheels from the drawer slide in the middle of the sliders inside the cabinet.
- If the top drawer doesn't fit, and there is a gap at the bottom and/or the top drawer hits the top panel, make sure the drawers are sliding through the cabinet sliders, not on top of them. Also review the assembly done in steps **2** and **19** for the correct assembly of the sliders.

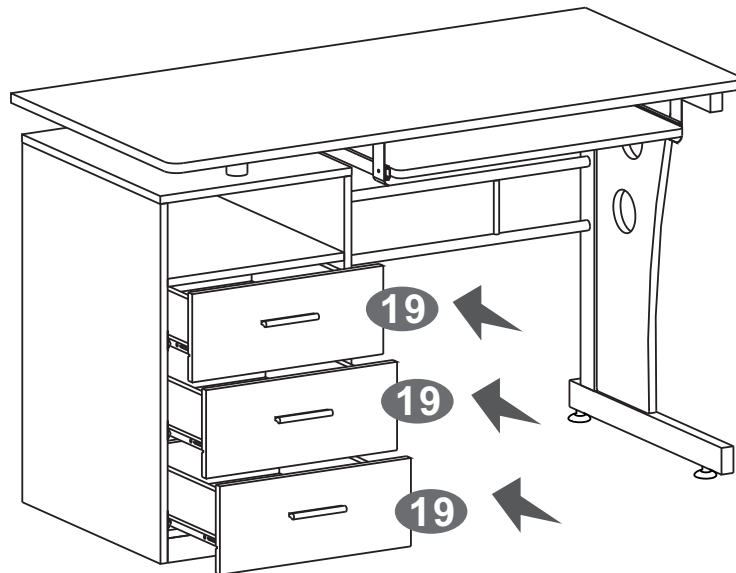



ALL DONE!

Give yourself a nice pat on the back. You did a great job!

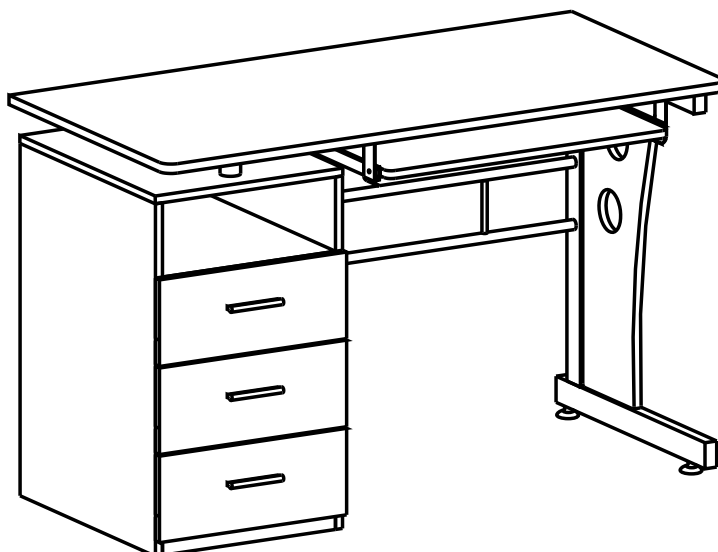

CARE, MAINTENANCE AND SAFETY WARNINGS:

WEIGHT LIMITS

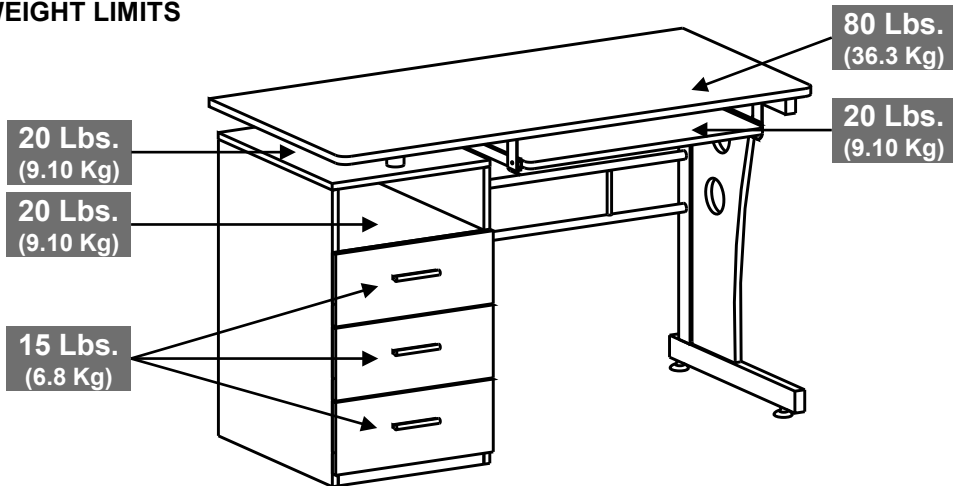

- Do not exceed the indicated weight limits.
- Do not expose the surfaces to direct sunlight or to extreme environmental conditions.
- Clean the surfaces preferable with a clean cloth damped in a solution of mild soap and water, then dry with a clean towel.
- Do not use solvents or abrasive materials to clean the unit.
- If you decide to use a cleaning agent, test first on an area hidden from view such as underneath the keyboard panel.
- Do not sit on the unit or lean against it.
- Do not allow small children to play under or over the unit.
- Do not allow small children to reach inside the drawers or compartment without your supervision.
- Do not pull, push or drag the unit to move it for more than 1 feet. The unit must be lifted by at least 2 persons when moving in the same or adjacent rooms.
- Before moving the unit, make sure to secure or remove any object that is heavy or might fall off. Please note that lifting from the tabletop with too much weight on the product might lead to part damage/separation.
- When lifting the unit, use both hands and bend your knees, not your backs.
- When transporting the unit to places far away, protect and secure the unit to avoid damage in transit.
- Shall any part of the unit become defective during the warranty period, replacement parts might be available to you at no charge. Please refer to the last pages on this manual.
- The warranty does not extend to regular wear and tear, nor the manufacturer assumes liability for damages or consequences due to accidents, incorrect assembly, negligence, improper use, modifications, or not heeding the above warnings.

TECHNI MOBILI DESK WARRANTY

DESKS/LAPTOP CARTS/FILE CABINETS: LIMITED 5-YEAR WARRANTY

RTA Products, LLC warrants to the Original Purchaser who acquired a new product from RTA Products or its authorized resellers that this product will be free from defects in its workmanship and materials, under normal use and service conditions, as described herein. "Defects" as used in this warranty, is defined as any imperfections that impair the use of the furniture or product. RTA Products LLC will replace any defective part, at its discretion, and without charge to the original purchaser other than the freight from the end consumer to RTA Products.

Replacement parts can only be supplied if parts are available. Items out of production may be unavailable. This warranty will be effective for the applicable time period beginning the date of purchase on your original sales receipt. RTA product's obligation under this warranty is limited to repairing or replacing products or parts as provided herein. This product has been designed for and is intended for office and home-office use only. This warranty is Original Purchaser's sole remedy for product defects, and this warranty does not extend to any product, or damage to any product, caused by or attributed to abuse or misuse, products used for commercial or rental purposes, use modifications of, or attachments to the product, and products or parts not used, maintained, or extended hereunder is in lieu of any and all other warranties, express or implied, including without limitations any implied warranty or merchantability or of fitness for a particular purpose. Please note, all desks made with PVC Laminate surface should not be exposed to direct sunlight, as it may damage the material. Damage of this nature is not covered under this warranty.

RTA Products will not be responsible for indirect, special, incidental or consequential damages. This warranty is limited to merchandise purchased in the Continental United States, excludes AK, HI and PR. Some States do not allow the exclusion or limitation of incidental or consequential damages, so the above limitations or exclusions may not apply to you. This warranty gives you specific legal rights. You may also have other rights that may vary from state to state.

RTA Products will advise you of the procedure to follow in making warranty claims. The following are the procedures for warranty claims:

- a. Call us Monday – Friday, from 9am-5pm (Eastern Time) at (866) 782-5520 to explain the defect and give your name, address and phone number. Please have ready the model number of our product, date and place of purchase. You can also write to us by e-mail to warranty@rtaproducts.com and include the same information.
- b. If we determine that replacement will remedy the situation, and in order to determine the extent or the cause of the defect, purchaser will need to send the part in question at purchaser's expense. Once we receive the part, we will examine it and determine whether the claim is valid (or not), and then proceed to send the replacement. We will ship the replacement at our expense.

FOR SEVERAL HELP OPTIONS INCLUDING REPLACEMENT PARTS ORDERS

VISIT: WWW.TECHNIMOBILI.COM



CLICK ON SUPPORT TAB



Scan QR Code to order replacement parts

OR EMAIL US: SUPPORT@RTAPRODUCTS.COM