



ROLLING LAPTOP CART WITH STORAGE

MODEL RTA-B018

ASSEMBLY INSTRUCTIONS

Thank you for purchasing our product.

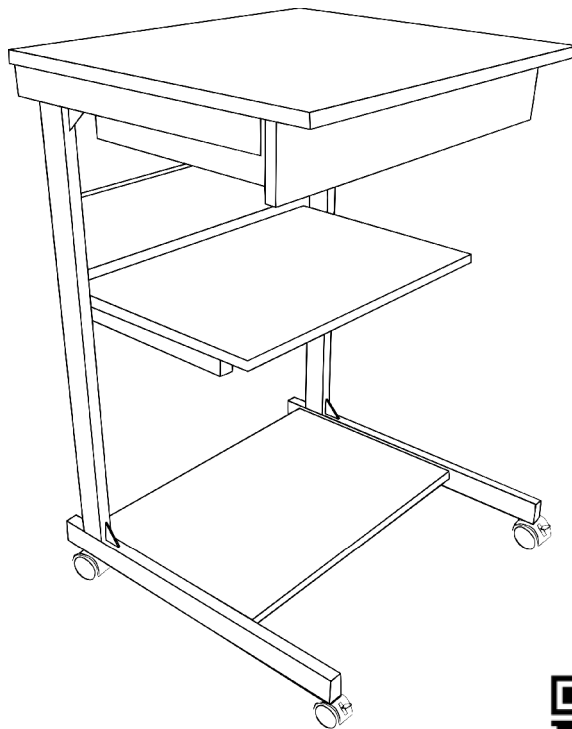

Scan QR code to
view assembly video

REV.CS-6886-0822



P.1	RTA-B018	P.1
-----	----------	-----



- Please read carefully the assembly instructions before the installation.



- Do not discard this manual or any of the packaging material until the unit has been completely assembled.



- Scan the above QR code to view the complete assembly video online.
- For individual Step videos –please use the QR code found on the corresponding step within the manual.

Do a quick inventory of all the parts and hardware listed in the following pages.



Missing, damaged and defective parts can be replaced at no cost to you. Please refer to the last pages on this manual.



The replacement parts service is limited to the 48 contiguous United States. If you reside in AK, HI, PR, U.S. territories or other countries, please contact the supplier from where the unit was purchased.



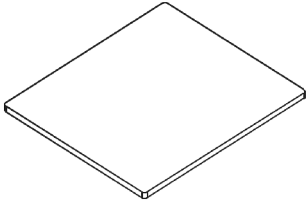
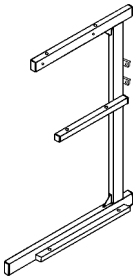
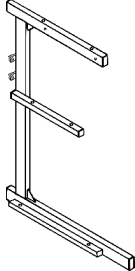
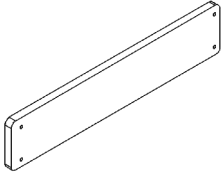
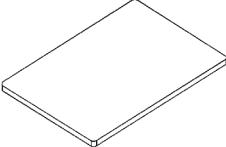
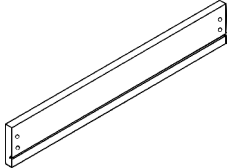
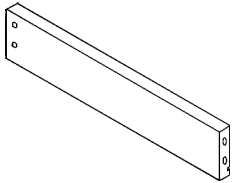
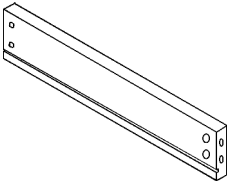
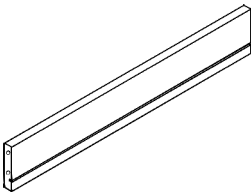
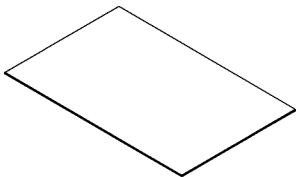



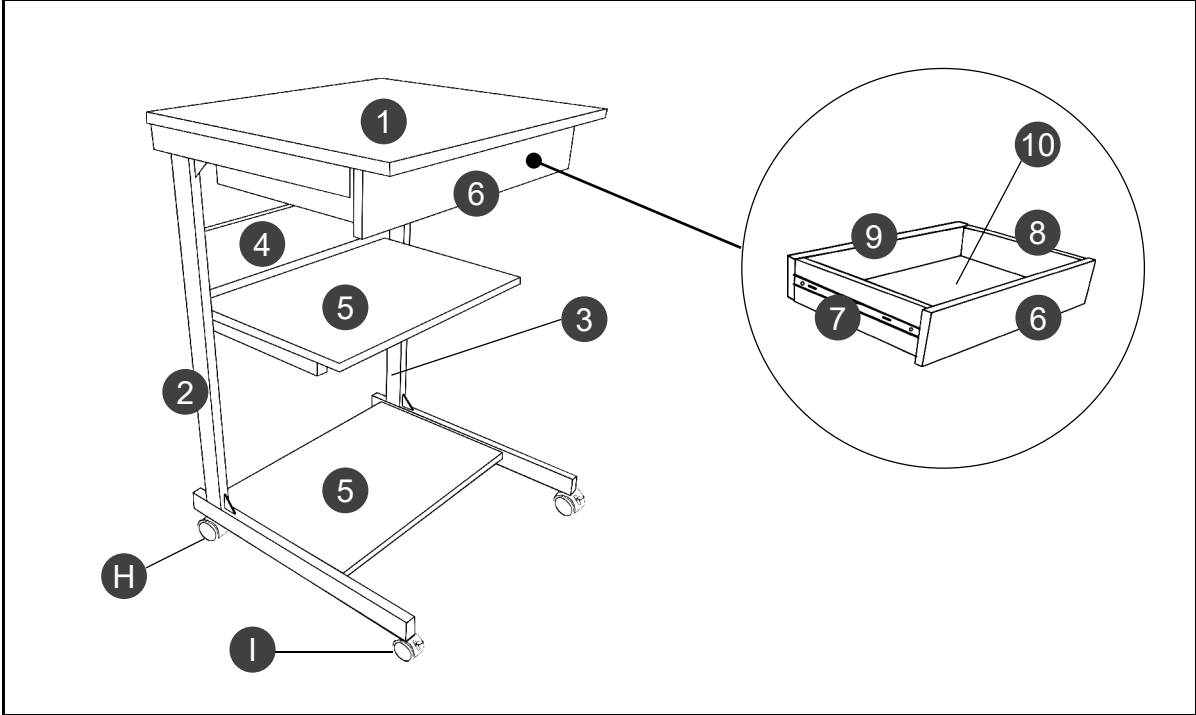



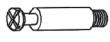

MAIN PARTS LIST		
1 x1 Top panel 	2 x1 Left frame 	3 x1 Right frame 
4 x1 Back panel 	5 x2 Shelf 	6 x1 Drawer front panel 
7 x1 Drawer left panel 	8 x1 Drawer right panel 	9 x1 Drawer back panel 
10 x1 Drawer bottom board 		

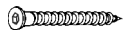
MAIN PARTS LAYOUT (FOR REFERENCE):

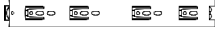

LIST OF INCLUDED HARDWARE AND TOOLS

PART	QTY	ITEM	
A	4	M6x50	
B	8	M6x30	
C	4	M6x30 Cam bolt	
D	8	M4x12	
E	4	M4x35	
F	4	M6x12	
G	4	Cam lock	

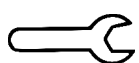
PART	QTY	ITEM	
H	2	Non-locking caster (back)	
I	2	Locking caster (front)	
J	2	Sliders	
	1	Allen Wrench	
	1	Wrench (Spanner)	

OTHER TOOLS THAT ARE REQUIRED (But not included with the product)

Phillips Screwdriver	
----------------------	--------------------------------------------------------------------------------------

BEFORE YOU START THE ASSEMBLY, PLEASE READ THE FOLLOWING TIPS AND WARNINGS.

- If during assembly you find an issue or need clarification, please contact our Customer Service for assistance. Please refer to the last pages on this manual.



- On each step read the instructions thoroughly and analyze the illustrations before proceeding to do the assembly.
- Follow the instructions step by step and do not skip any unless our Customer Service advises it is OK to do so.



- Make sure you understand which hardware will be used on each step. Using the wrong size of screw, bolt or pin might strip the threads or cause damage to the part in which it is being used.

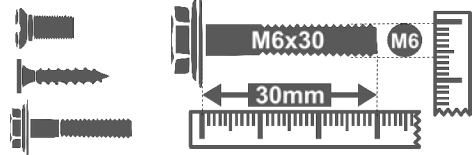

- To avoid misalignments, always leave the screws loose and tighten them until all pieces are positioned correctly.



- Do not overtighten or force the screws as they might break, strip, damage the threads of the holes or get stuck inside the part.

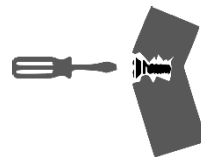

- Sometimes on wooden panels, the laminate might cover partially or entirely the screw hole. If the hole is not visible, pass and press the tip of your finger over the area where it is supposed to be located to feel the indentation, and once found, carefully pierce the laminate to reveal the hole underneath.



- If the hole seems too small for the screw, first make sure you are using the correct size of screw and that it's been installed in the correct hole. If the hole still appears to be too small, carefully pierce the laminate to reveal the hole's actual size.



ASSEMBLY STEPS

STEP 1

Hardware:

J		2 Pcs
	Slider	



Scan QR Code to view this step

Grab and extend each of the sliders **J** towards your **RIGHT** and separate the small track from the rest by pressing **UP** firmly the locking lever, at the same time that you pull the small track out. The big pieces **J-1** will be used in the next step, while the small tracks **J-2** will be used until step **9**, so please set them aside.

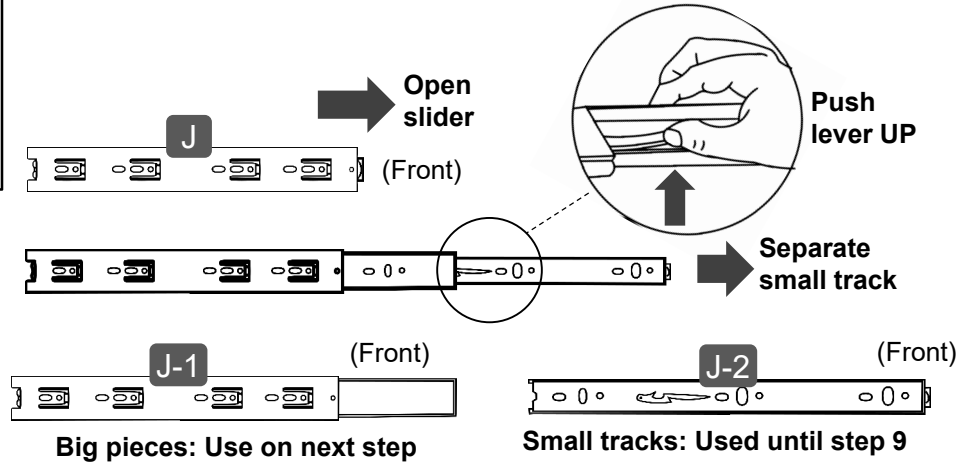

STEP 2

Hardware:

D		4 Pcs
	M4x12	

J-1		2 Pcs
	Big	

Tools required
(But not included)

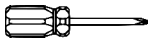

Scan QR Code to view this step

On the big sliders **J-1** slide the piece with the ball bearing towards the middle to clear the opening for the front hole, then attach the sliders to the top bar on the left frame **2** and the right frame **3** with screws **D** using a screwdriver (not included).

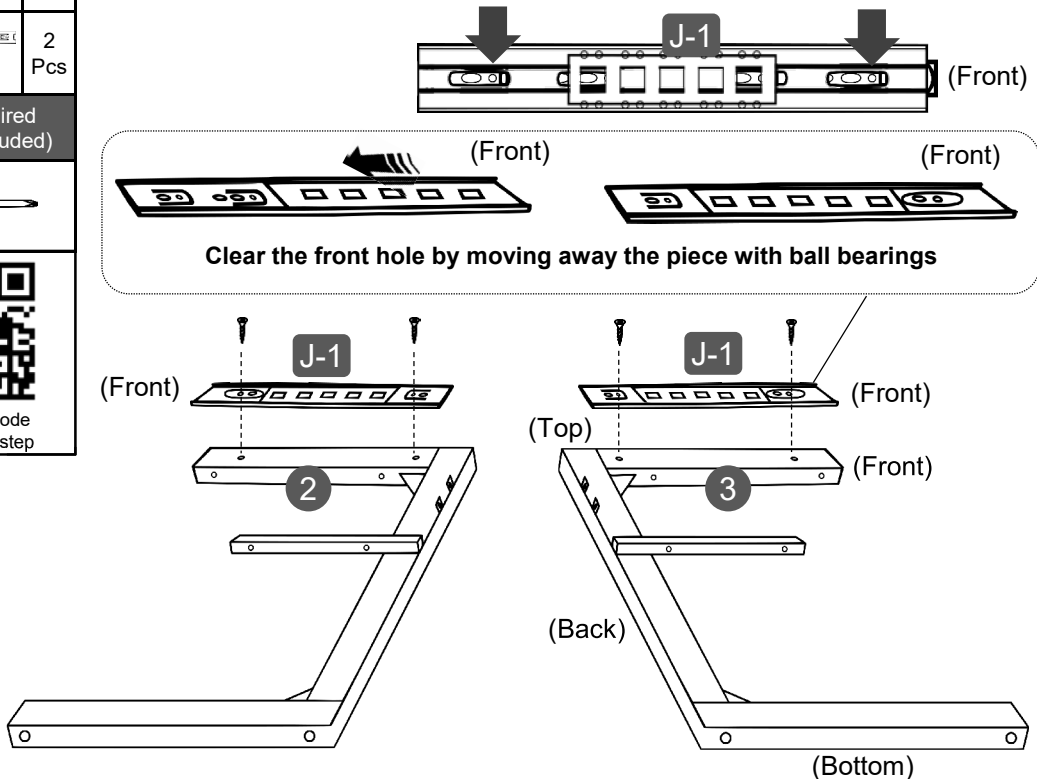

STEP 3

Hardware:

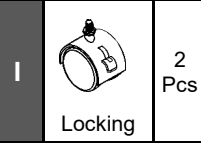
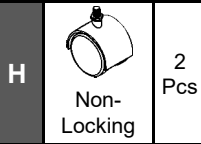

Tools required

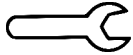

Scan QR Code to view this step

Attach the casters **H** and **I** to the bottom of the frames **2** and **3** using the wrench, and following this order:

- The Non-Locking casters **H** go at the back of the frame.
- The Locking casters **I** go at the front of the frame.

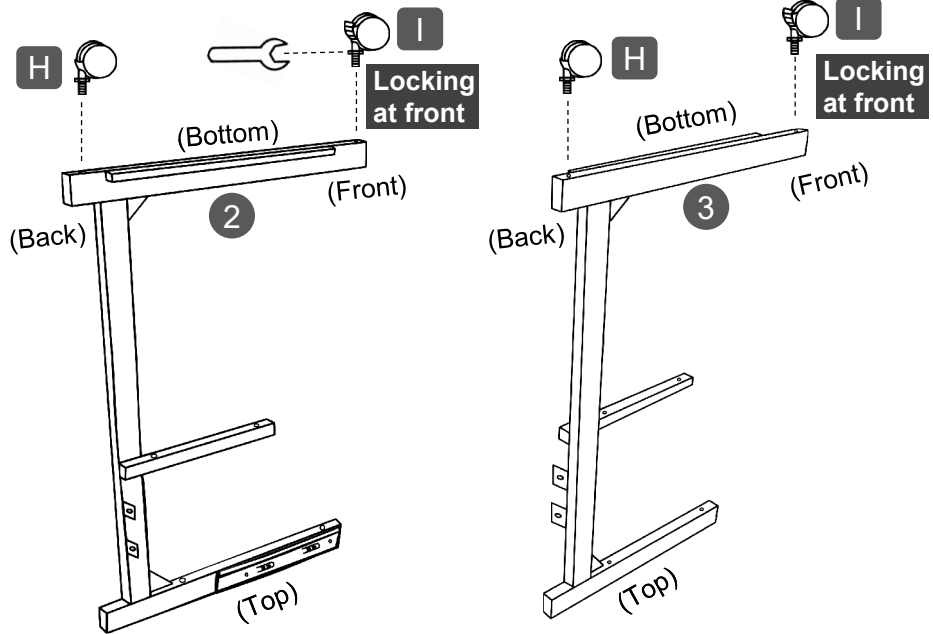

STEP 4

Hardware:



Tools required



Scan QR Code to view this step

Assemble the back panel **4** to the frames **2** and **3** with screws **F** but do not tighten yet. The screws go through the tabs on the frames and into the panel.

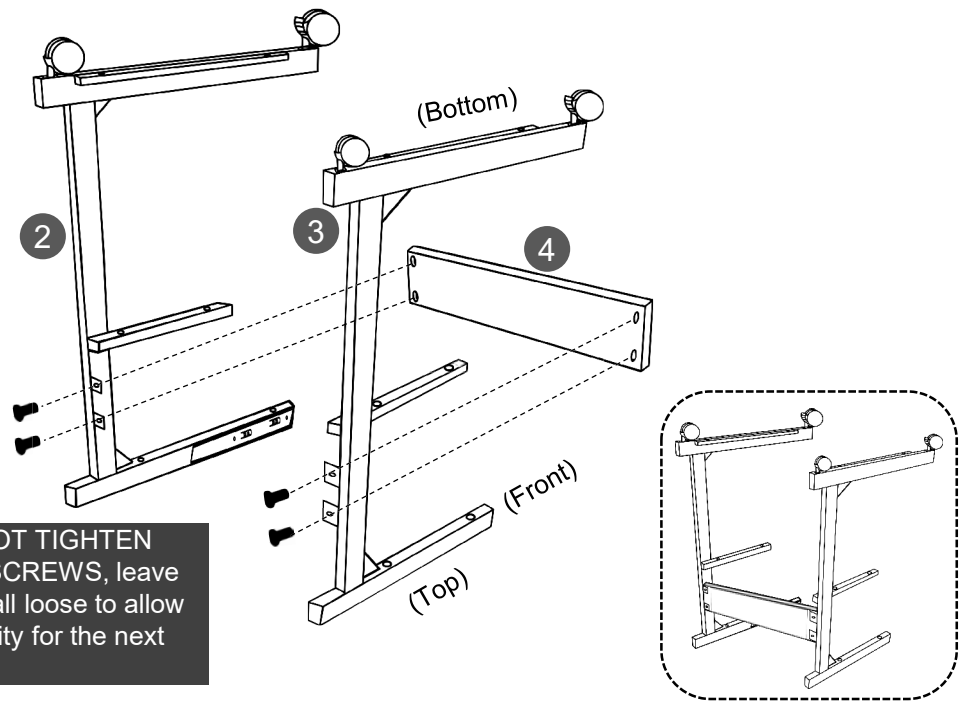

DO NOT TIGHTEN THE SCREWS, leave them all loose to allow flexibility for the next steps.

STEP 5

Hardware:



Tools required



Scan QR Code to view this step

- Place the tabletop **1** upside-down on the floor over a blanket to protect its surface, and place the frames **2** and **3** over it making the holes coincide, and secure with screws **A** but do not tighten yet.
- Turn the unit over its back side to have it ready for the next step.

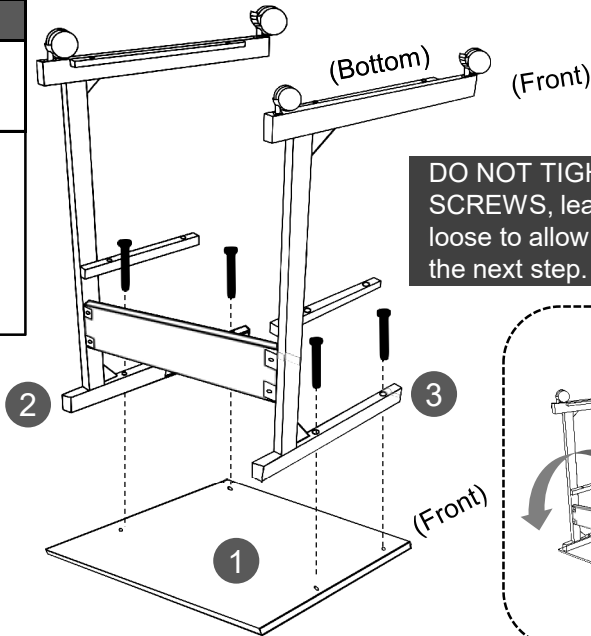

DO NOT TIGHTEN THE SCREWS, leave them all loose to allow flexibility for the next step.

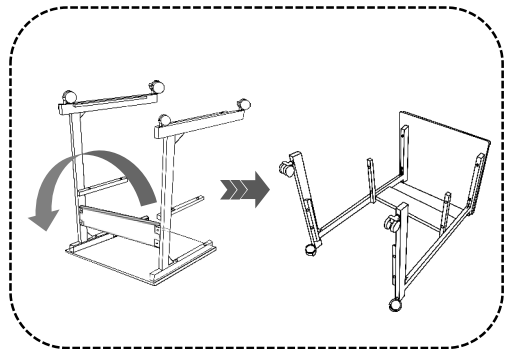

STEP 6

Hardware:



Tools required



Scan QR Code to view this step

- Assemble the shelf panels **5** to the middle and bottom bars on the frames **2** and **3** with screws **B** from underneath as shown, but do not tighten any screws until finished with this step.
- Afterwards, you can proceed to **tighten all the screws** left loose from steps **4**, **5** and **6**, and turn the unit upright.

ALSO TIGHTEN ALL THE SCREWS FOR THE TOP AND BACK

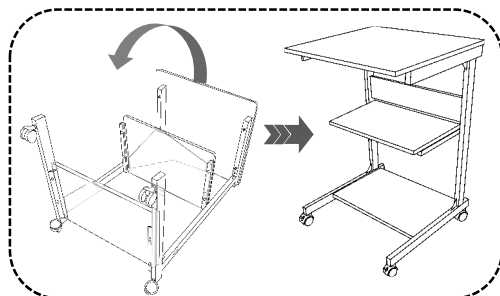
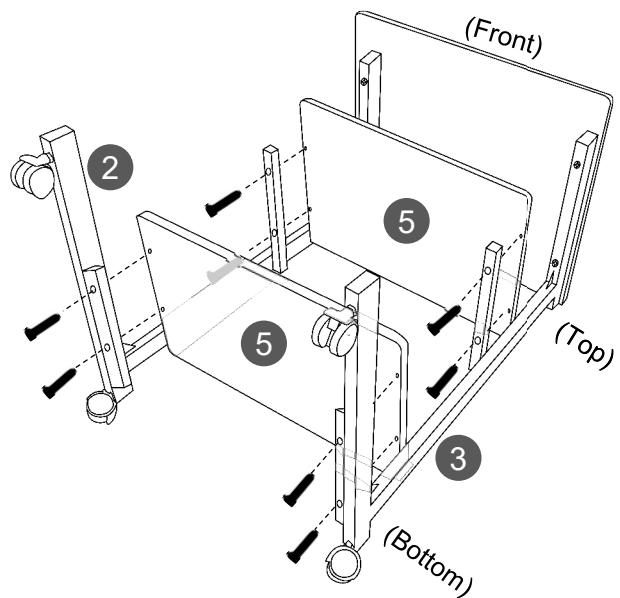

STEP 7

Hardware:

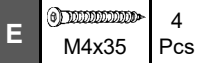

Tools required



Scan QR Code to view this step

- Assemble the drawer side panels **7** and **8** to the drawer back panel **9** with screws **E** from the side.
- Slide the drawer bottom panel **10** through the grooves of the side panels **7** and **8**, and into the groove of panel **9**.

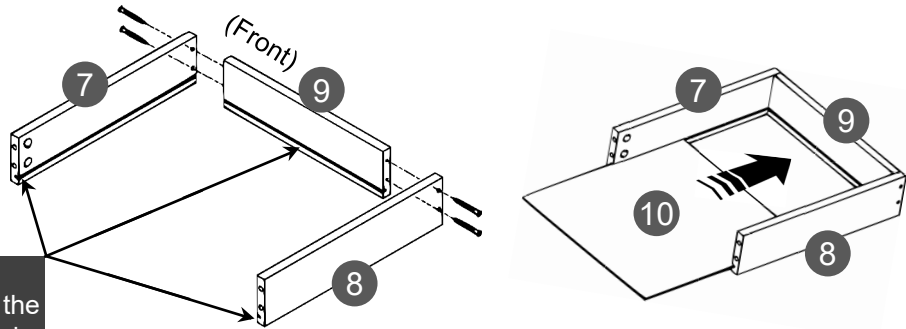

Make sure all the grooves match at the bottom of the panels

STEP 8

Hardware:



Tools required
(But not included)

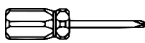

Scan QR Code to view this step

- Attach the bolts **C** to the front panel **6**.
- Join panel **6** to panels **7** and **8**.
- Insert the cam locks **G** into panels **7** and **8** and turn them to lock all the 3 panels. Please pay attention to the cam lock alignment.

FIRST:

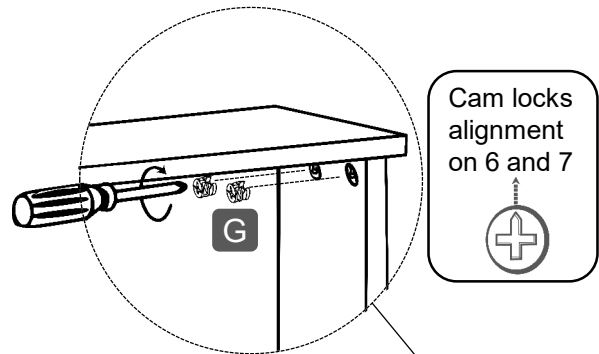

Cam locks alignment on 6 and 7



THEN:

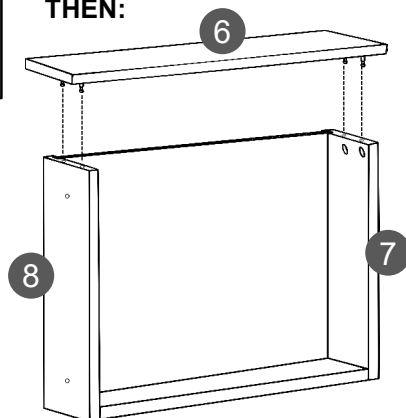

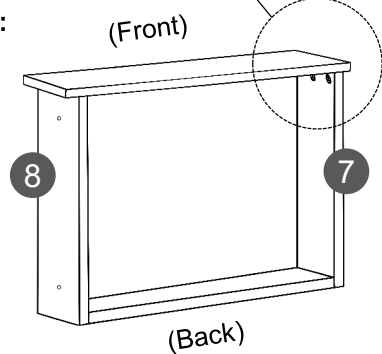

LAST:



STEP 9

Hardware:

D		4
	M4x12	Pcs
J-2		2
	Small	Pcs

Tools required
(But not included)

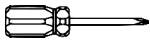

Scan QR Code
to view this step

Attach the small sliders **J-2** to the side panels **7** and **8** with screws **D**.

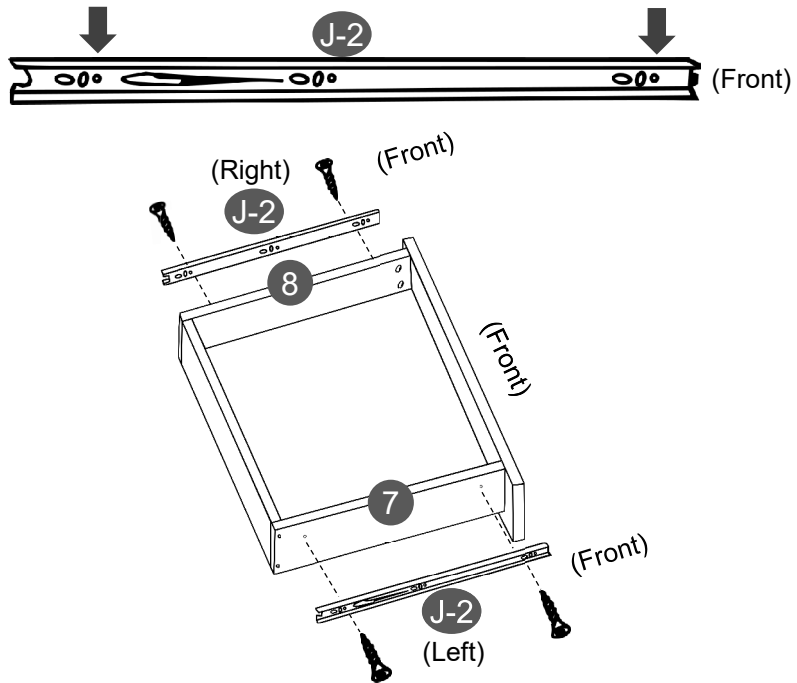

STEP 10



Scan QR Code
to view this step

- On the frame first make sure that the piece with the ball bearing is all the way to the front.
- Insert the drawer making sure that simultaneously on both sides, the tracks **J-2** on the drawer go through the black plastic guides and the ball bearing pieces on the sliders **J-1**.
- Push in the drawer slowly into the unit.

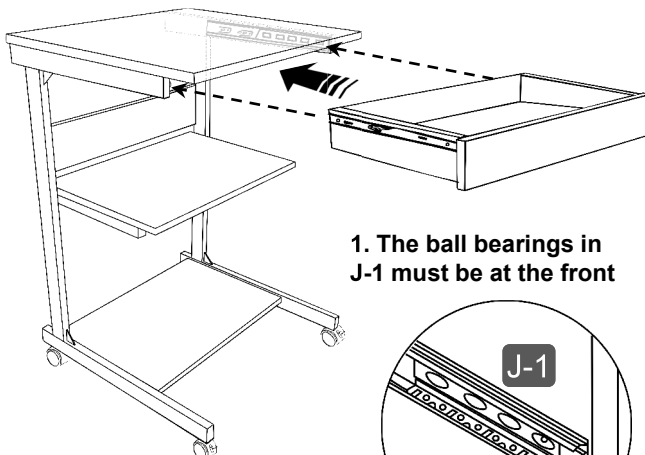

1. The ball bearings in J-1 must be at the front

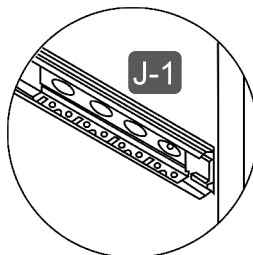

2. J-2 goes through the plastic guide and the ball bearings on J-1

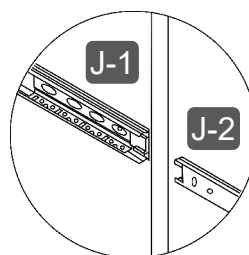

3. Push in very slowly.

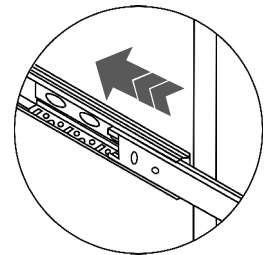



ALL DONE!

Give yourself a nice pat on the back, you did a great job!

Enjoy your new unit.

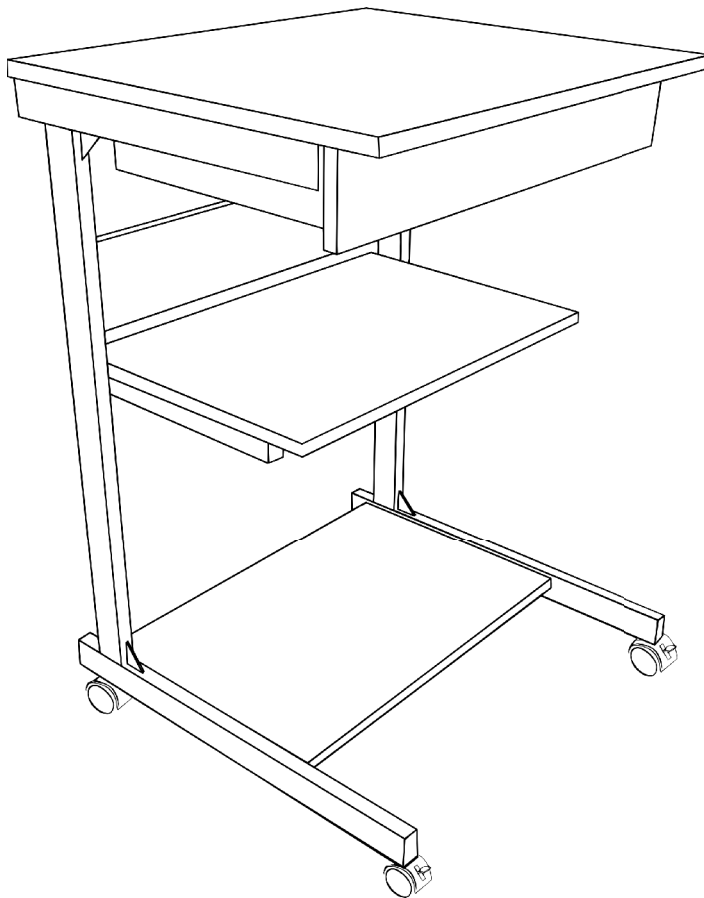

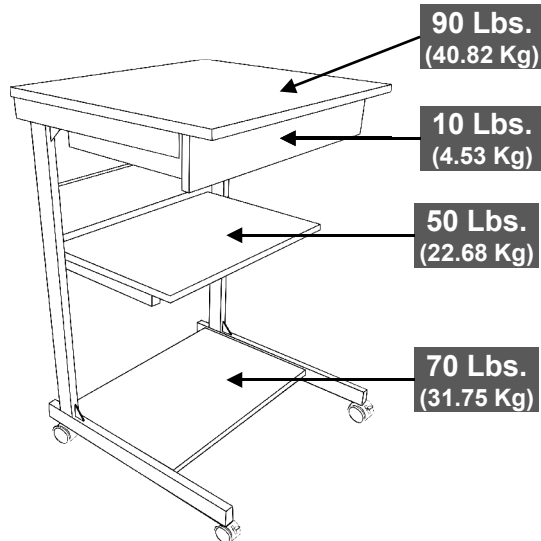
WEIGHT LIMITS**WEIGHT LIMITS****CARE, MAINTENANCE AND SAFETY WARNINGS:**

- Do not exceed the indicated weight limits.
- Do not expose the surfaces to direct sunlight or to extreme environmental conditions.
- Clean the surfaces preferable with a clean cloth dampened in a solution of mild soap and water, then dry with a clean towel.
- Do not use solvents or abrasive materials to clean the unit.
- If you decide to use a cleaning agent, test first on an area hidden from view such as underneath the drawer.
- Do not sit on the unit or lean against it.
- Do not allow small children to play with the unit or use it as a moving vehicle.
- Do not allow small children to reach inside the drawer without your supervision.
- Before moving the unit, make sure to unlock the front casters.
- Before moving the unit, make sure to secure any object that might fall off.
- When transporting the unit to places far away, lock the front casters and protect and secure the unit to avoid damage in transit.
- Shall any part of the unit become defective during the warranty period, replacement parts might be available to you at no charge. Please refer to the last pages on this manual.
- The warranty does not extend to regular wear and tear, nor the manufacturer assumes liability for damages or consequences due to accidents, incorrect assembly, negligence, improper use, modifications, or not heeding the above warnings.

TECHNI MOBILI DESK WARRANTY

DESKS/LAPTOP CARTS/FILE CABINETS: LIMITED 5-YEAR WARRANTY

RTA Products, LLC warrants to the Original Purchaser who acquired a new product from RTA Products or its authorized resellers that this product will be free from defects in its workmanship and materials, under normal use and service conditions, as described herein. "Defects" as used in this warranty, is defined as any imperfections that impair the use of the furniture or product. RTA Products LLC will replace any defective part, at its discretion, and without charge to the original purchaser other than the freight from the end consumer to RTA Products.

Replacement parts can only be supplied if parts are available. Items out of production may be unavailable. This warranty will be effective for the applicable time period beginning the date of purchase on your original sales receipt. RTA product's obligation under this warranty is limited to repairing or replacing products or parts as provided herein. This product has been designed for and is intended for office and home-office use only. This warranty is Original Purchaser's sole remedy for product defects, and this warranty does not extend to any product, or damage to any product, caused by or attributed to abuse or misuse, products used for commercial or rental purposes, use modifications of, or attachments to the product, and products or parts not used, maintained, or extended hereunder is in lieu of any and all other warranties, express or implied, including without limitations any implied warranty or merchantability or of fitness for a particular purpose. Please note, all desks made with PVC Laminate surface should not be exposed to direct sunlight, as it may damage the material. Damage of this nature is not covered under this warranty.

RTA Products will not be responsible for indirect, special, incidental or consequential damages. This warranty is limited to merchandise purchased in the Continental United States, excludes AK, HI and PR. Some States do not allow the exclusion or limitation of incidental or consequential damages, so the above limitations or exclusions may not apply to you. This warranty gives you specific legal rights. You may also have other rights that may vary from state to state.

RTA Products will advise you of the procedure to follow in making warranty claims. The following are the procedures for warranty claims:

- a. Call us Monday – Friday, from 9am-5pm (Eastern Time) at (866) 782-5520 to explain the defect and give your name, address and phone number. Please have ready the model number of our product, date and place of purchase. You can also write to us by e-mail to warranty@rtaproducts.com and include the same information.
- b. If we determine that replacement will remedy the situation, and in order to determine the extent or the cause of the defect, purchaser will need to send the part in question at purchaser's expense. Once we receive the part, we will examine it and determine whether the claim is valid (or not), and then proceed to send the replacement. We will ship the replacement at our expense.

FOR SEVERAL HELP OPTIONS INCLUDING REPLACEMENT PARTS ORDERS

VISIT: WWW.TECHNIMOBILI.COM



AND CLICK ON SUPPORT TAB

Or scan the following QR Code:



Scan the following QR Code to order replacement parts:



EMAIL US:

SUPPORT@RTAPRODUCTS.COM

