

MODEL RTA-4985

ASSEMBLY INSTRUCTIONS

(REV.8-OL-9162-0825)

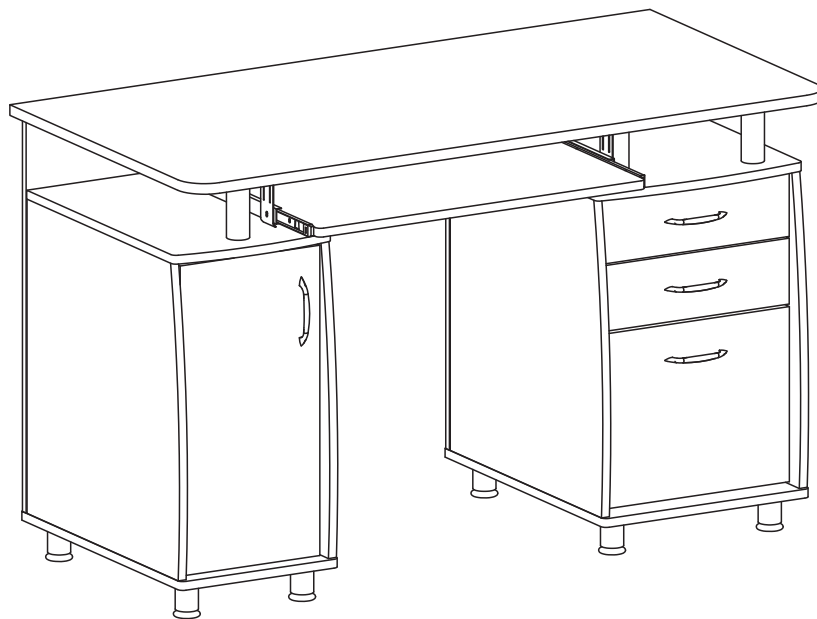

Thank you for purchasing our product!

 **Visit our Website**
technimobili.com



 **View Assembly Video**
technimobili.com/pages/assembly-videos

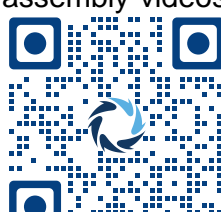

 **Contact Us**
support@rtaproducts.com



MAIN PARTS LIST

<p>#1 CPU Left</p>	<p>#2 CPU Right</p>	<p>#3 Glide Studs x8</p>	<p>#4 CPU Bottom</p> <p>(Top surface shown)</p>
<p>#7 Leg tube (1.8" Tall) x8</p>	<p>#8 Hinges x2</p>	<p>#5 CPU Back</p>	<p>#6 CPU Top</p>
<p>#10 Adjustable Shelf</p>	<p>#11 File Cabinet Bottom</p>	<p>#12 File Cabinet Left</p>	<p>#13 File Cabinet Right</p>
<p>#14 Drawer metal sliders, SET of 4 pcs for each drawer x3 Sets</p> <p>"FLAT" Shaped: 2 Pcs RIGHT LEFT</p> <p>"L" Shaped: 2 Pcs RIGHT LEFT</p>	<p>#15 File Cabinet Back</p>	<p>#16 File Cabinet Top</p>	<p>#17 Central Back</p>

For support with assembly questions & replacement parts please email us at: support@rtaproducts.com





Free shipping within **the 48 Contiguous United States.**

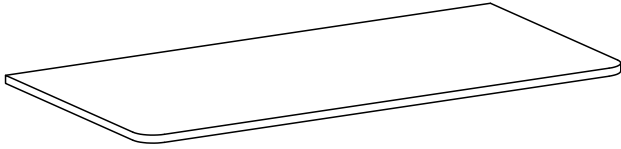
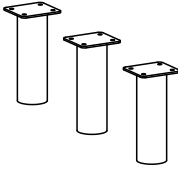
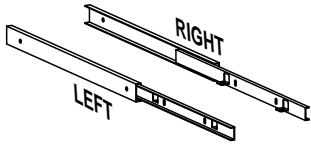
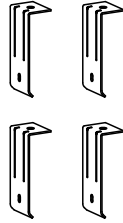

For international customers & **AK-HI-PR** orders, **the customer is responsible for shipping costs plus any International local taxes or duties.**

MAIN PARTS LIST (Continue)

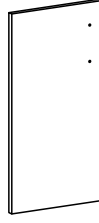
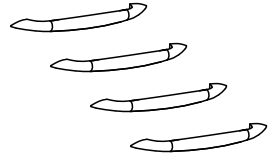
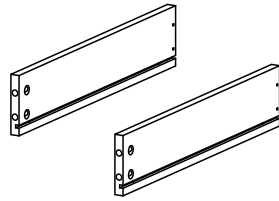
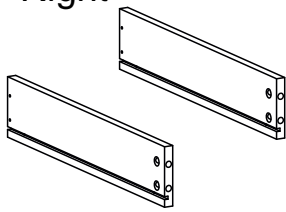
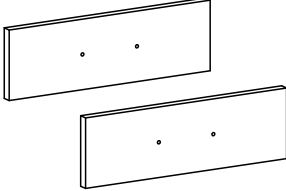
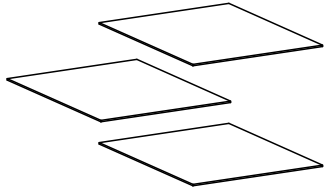
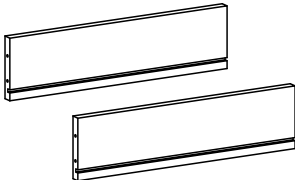
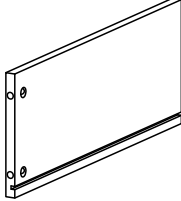
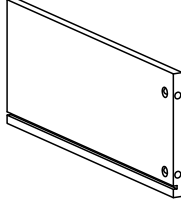
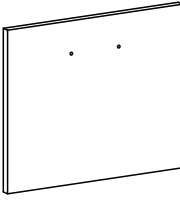
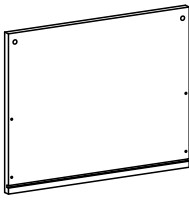
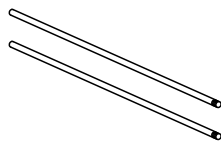
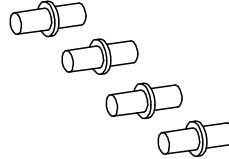
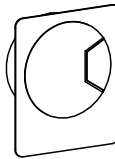
<p>#18 Tabletop</p> 	<p>#19 Tabletop Tube (4.75" Tall)</p> <p>x3</p> 	<p>#20 Keyboard Sliders, SET of 2 pcs</p> <p>x1 SET</p> 	
<p>#21 Brackets</p> <p>x4</p> 	<p>#22 Keyboard Tray</p> 	<p>#23 Door</p> 	<p>#24 Handles</p> <p>x4</p> 
<p>#25 Small Drawer Left</p> <p>x2</p> 	<p>#26 Small Drawer Right</p> <p>x2</p> 	<p>#27 Small Drawer Front</p> <p>x2</p> 	<p>#28 Drawers Bottom</p> <p>x3</p> 
<p>#29 Small Drawer Back</p> <p>x2</p> 	<p>#30 File Drawer Left</p> 	<p>#31 File Drawer Back</p> 	<p>#32 File Drawer Front</p> 
<p>#33 File Drawer Back</p> 	<p>#34 File Tubes, SET of 2 pcs</p> <p>x1 SET</p> 	<p>#35 Metal Pins, SET of 4 pcs</p> <p>x1 SET</p> 	<p>#36 Grommet (Cable management)</p> 

For support with assembly questions & replacement parts please email us at: support@rtaproducts.com



Free shipping within **the 48 Contiguous United States.**



For international customers & **AK-HI-PR** orders, **the customer is responsible for shipping costs plus any International local taxes or duties.**

Main parts Layout (For Reference)

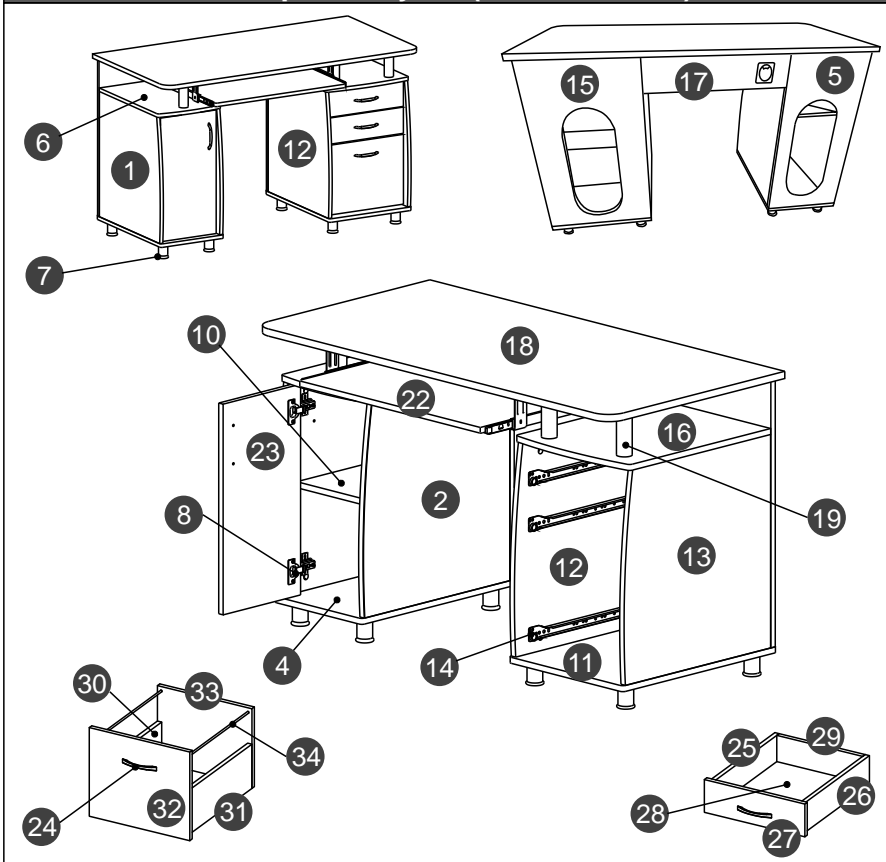

Hardware

No.	Item	Qty.
A	M6x35	3 Pcs
B	M4x35	12 Pcs
C	M3x15	24 Pcs
D	M4x20	8 Pcs
E	M6x40	16 Pcs
F	M4x14	48 Pcs

No.	Item	Qty.
G	M4x16	8 Pcs
H	M6x12	4 Pcs
I	M4x4	4 Pcs
J	M8 x Ø40 x 1.8 Soft plastic washer	3 Pcs
K	M6x25	32 Pcs

Included Tools

Phillips
Screwdriver

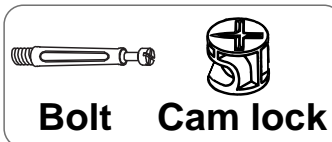

In some of the assembly steps you will use bolts and cam locks (also known as mini-fix). If you are not familiar with this kind of hardware, the below is a tutorial that explains how to use them.

The instructions below are ONLY A TUTORIAL for bolts and cam locks. The actual assembly starts on the next page.

1. Install the bolt into the first panel.

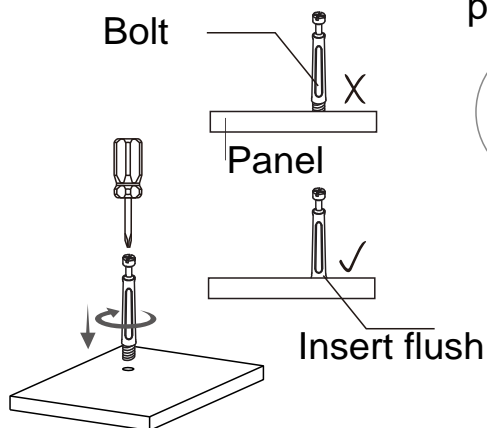

2. Join the second panel by inserting it into the bolt of the first panel.

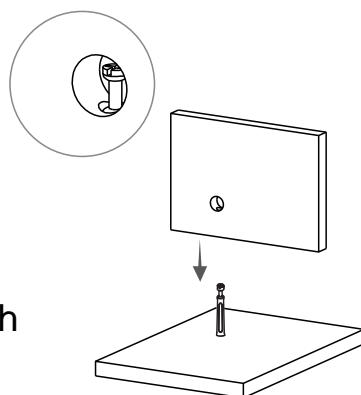

3. Insert the cam lock and turn it to lock both panels.

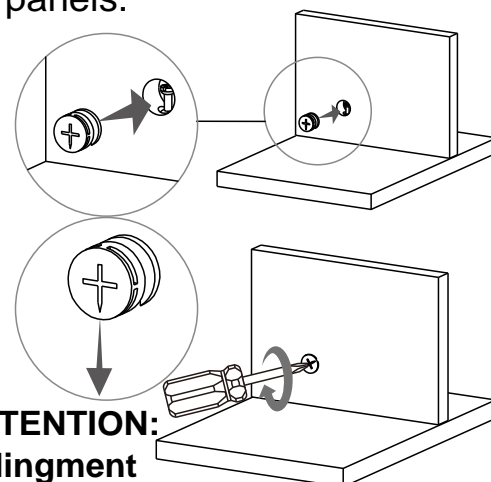

ASSEMBLY STEPS

WE RECOMMEND TO PLACE THE PIECES OVER BLANKETS OR TABLECLOTHS TO PROTECT THEIR FINISH DURING ASSEMBLY.

STEP 1

Hardware

F  32
M4x14 Pcs

Tools (included)



FIRST: Use F to attach #7 to the bottom surface of #4 and #11.

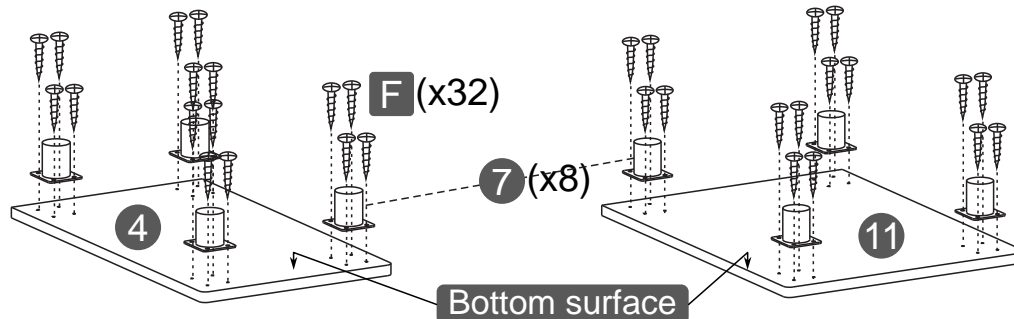

THEN: Attach #3.

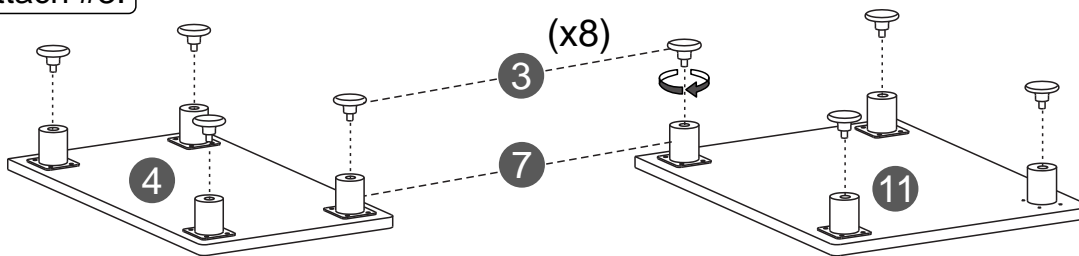

STEP 2

Hardware

E  8
M6x40 Pcs

K  4
M6x25 Pcs

Tools (included)

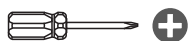

FIRST: Flip the panels #4 and #11, and attach E into the side holes.

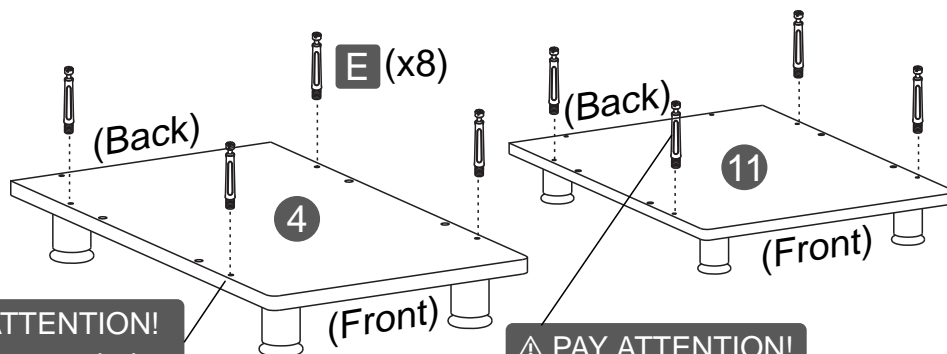
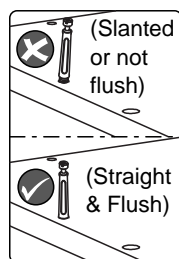

⚠ PAY ATTENTION!
Use the correct holes.

⚠ PAY ATTENTION!
Sides: Long bolts.

⚠ PAY ATTENTION!
Back: Short bolts.

THEN: Attach K into the back holes.

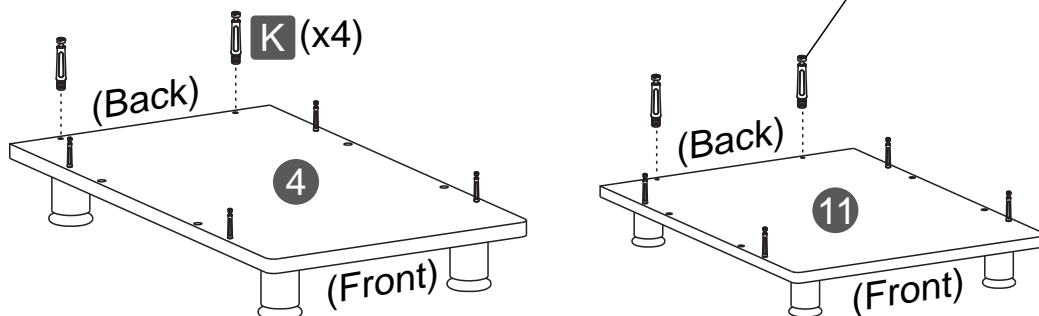

ASSEMBLY STEPS

STEP 3

Hardware

C M3x15 8 Pcs

Tools (included)



FIRST: Grab all the "L" shaped sliders #14 and set them aside for later.

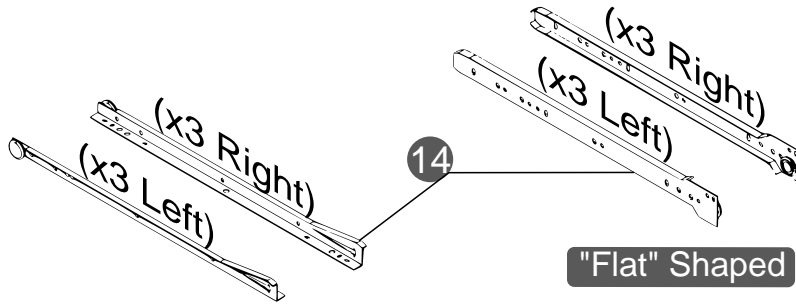

"Flat" Shaped (Use in this step)

"L" Shaped (Set aside for later)

THEN: Attach qty. 2 pairs of the "Flat" #14 to #12 and #13 at the top and middle with C. Save the 3rd pair for later.

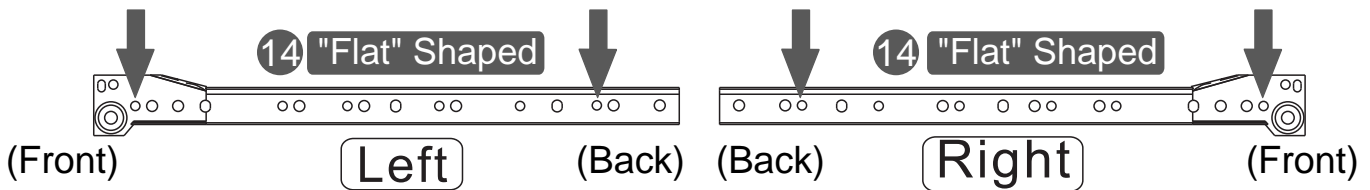

△ PAY ATTENTION!
Attach to TOP and MIDDLE sets of holes only

△ IMPORTANT!
Screw in as flush as possible.

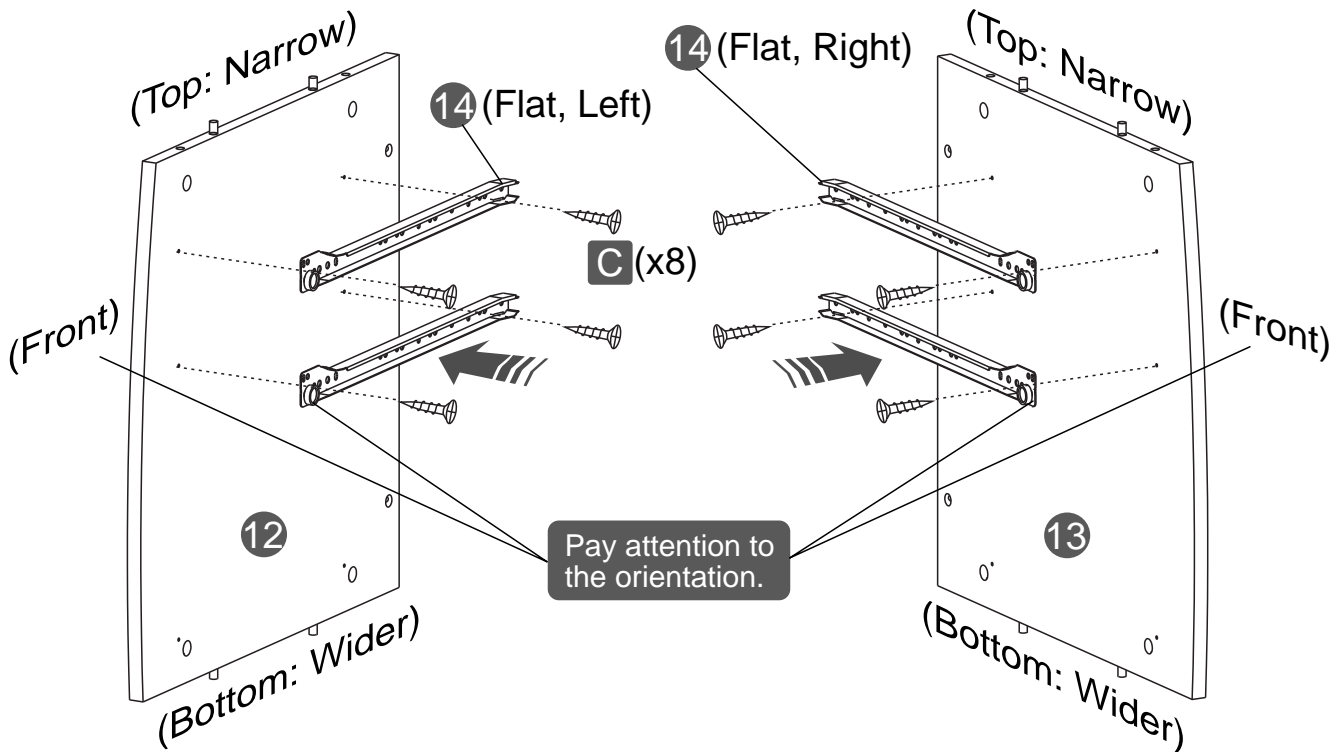

ASSEMBLY STEPS

STEP 4

Hardware

K		12
	M6x25	Pcs

Tools (included)



FIRST: Attach K to #5 and #15.

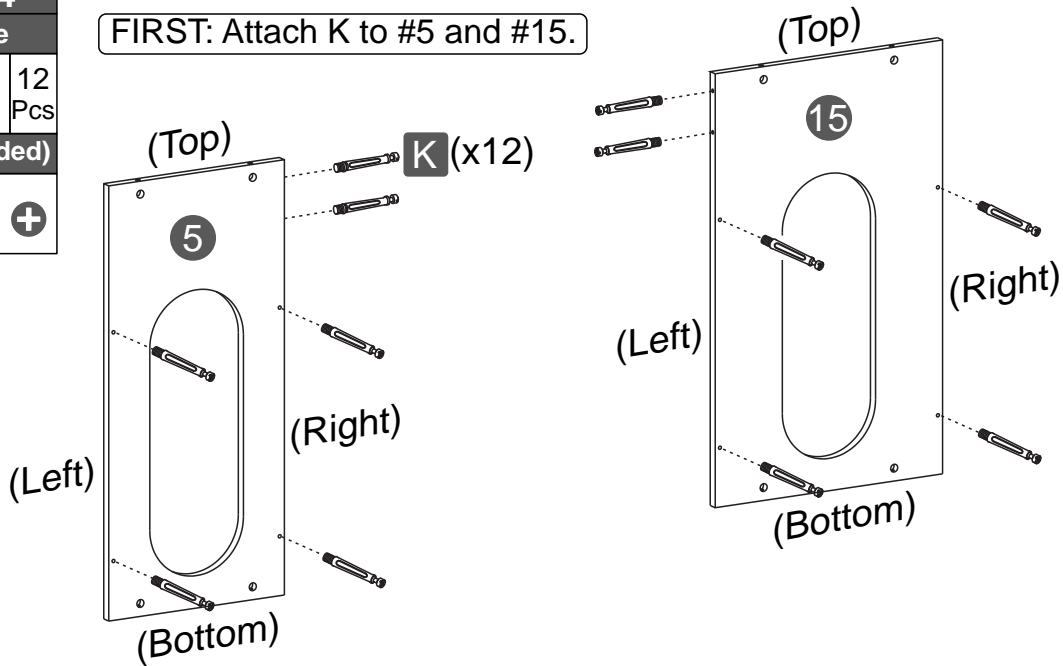

THEN: Assemble #5 to #1 and #2, and #15 to #12 and #13 respectively, and as explained in the TUTORIAL page.

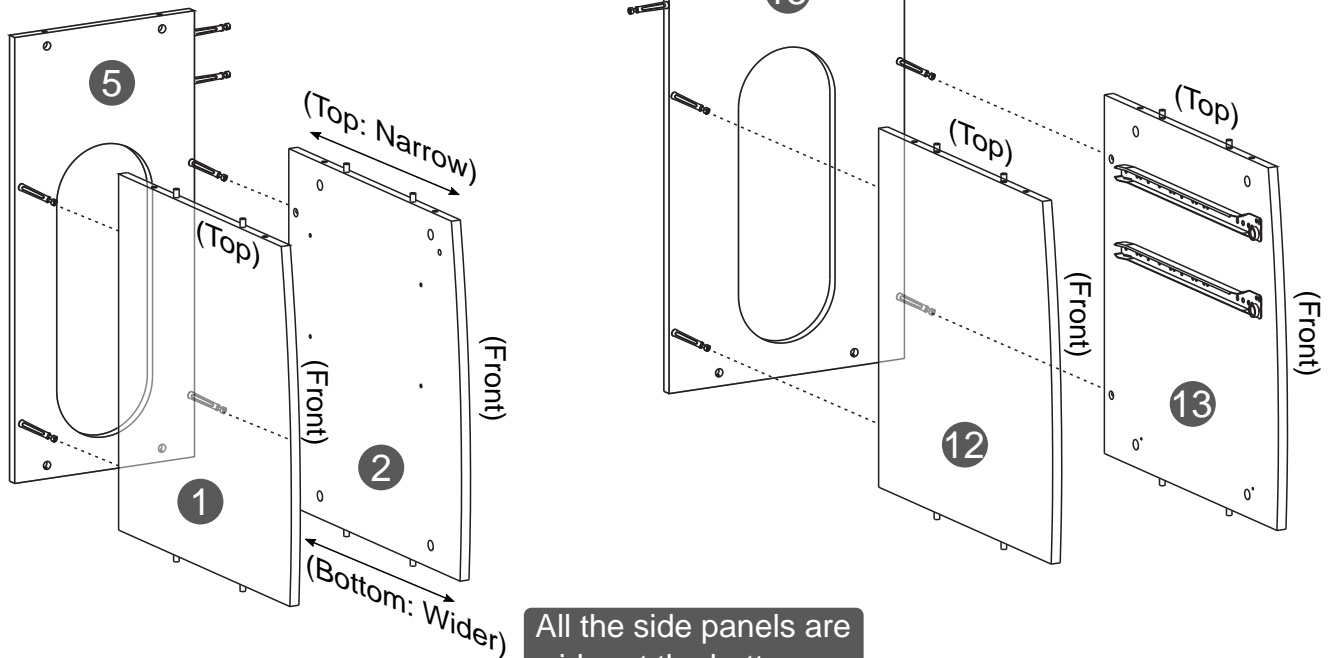
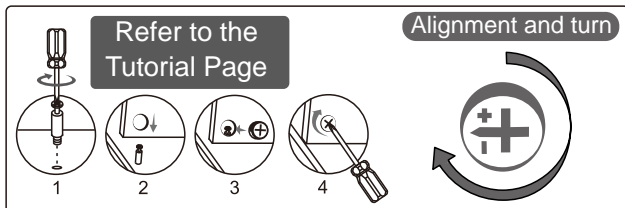

All the side panels are wider at the bottom

ASSEMBLY STEPS

STEP 5

Hardware

E  8
M6x40 Pcs

Tools (included)



Use E to assemble together:

- #1, #2, #4, #5 and #6.
- #11, #12, #13, #15 and #16.



Put 1-2-4-5-6 on the LEFT and
TIP! 11-12-13-15-16 on the RIGHT.

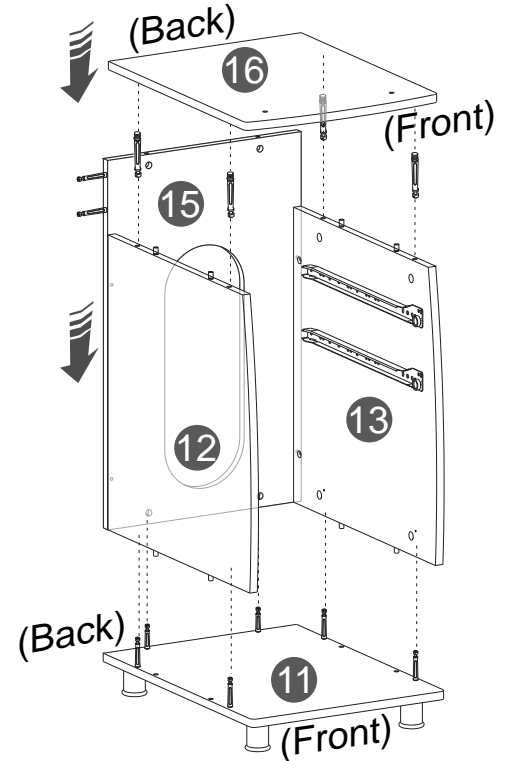
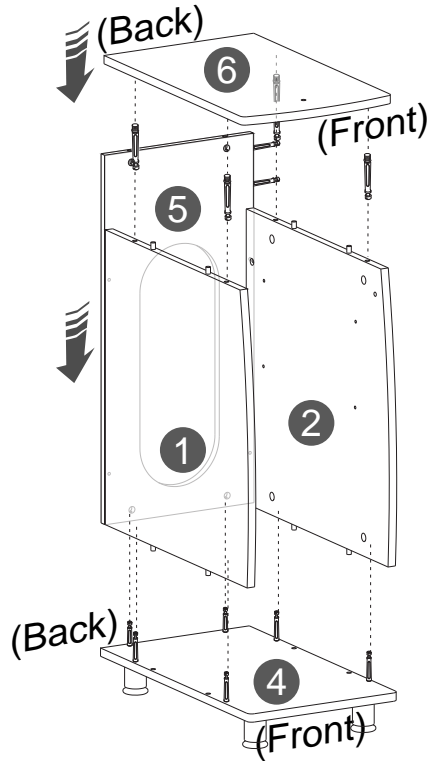
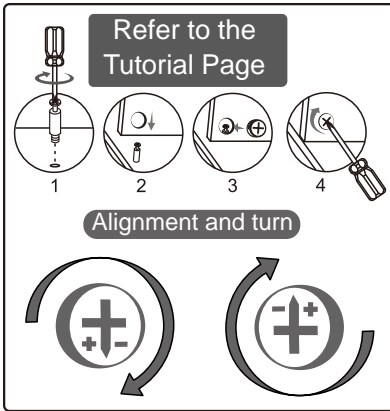

STEP 6

Hardware

C  4
M3x15 Pcs

Tools (included)



Attach the 3rd pair of the "Flat" #14 to #12 and #13 at the bottom with C.

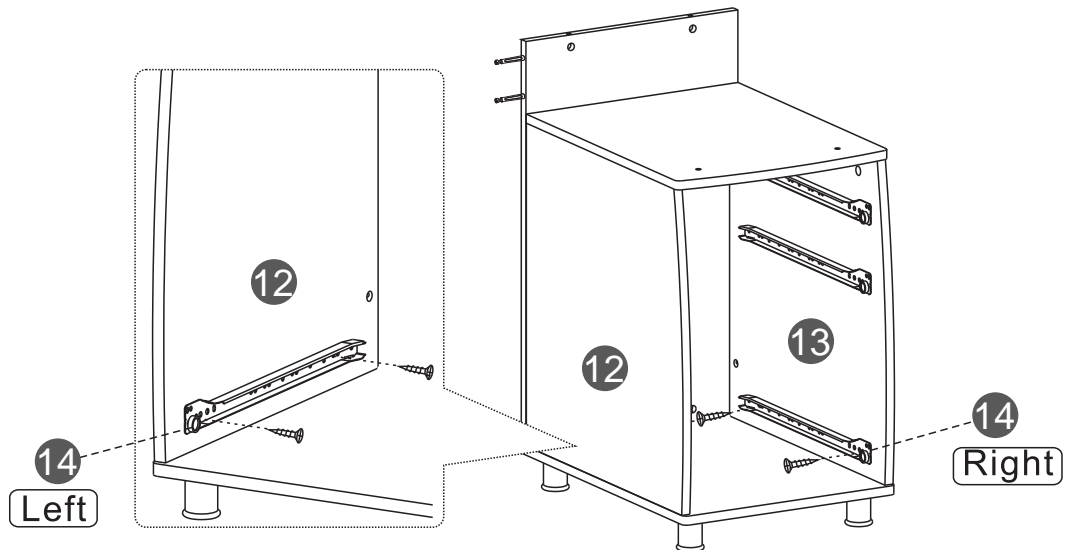
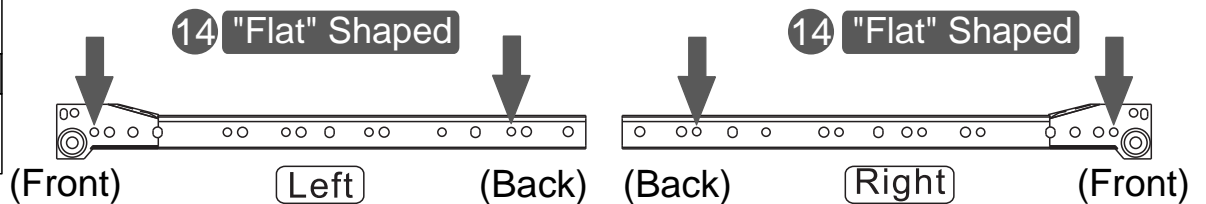

ASSEMBLY STEPS

STEP 7

This step requires of 2 people



Tools (included)



Assemble #17 in between #5 and #15 as explained in the TUTORIAL page, and attach #36 to #17 from behind.

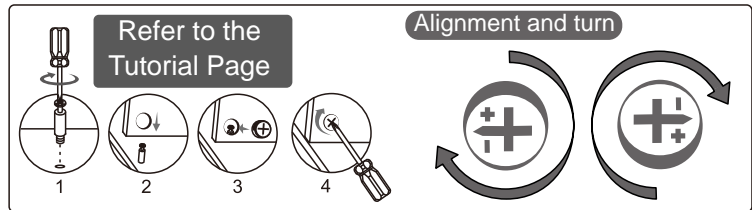
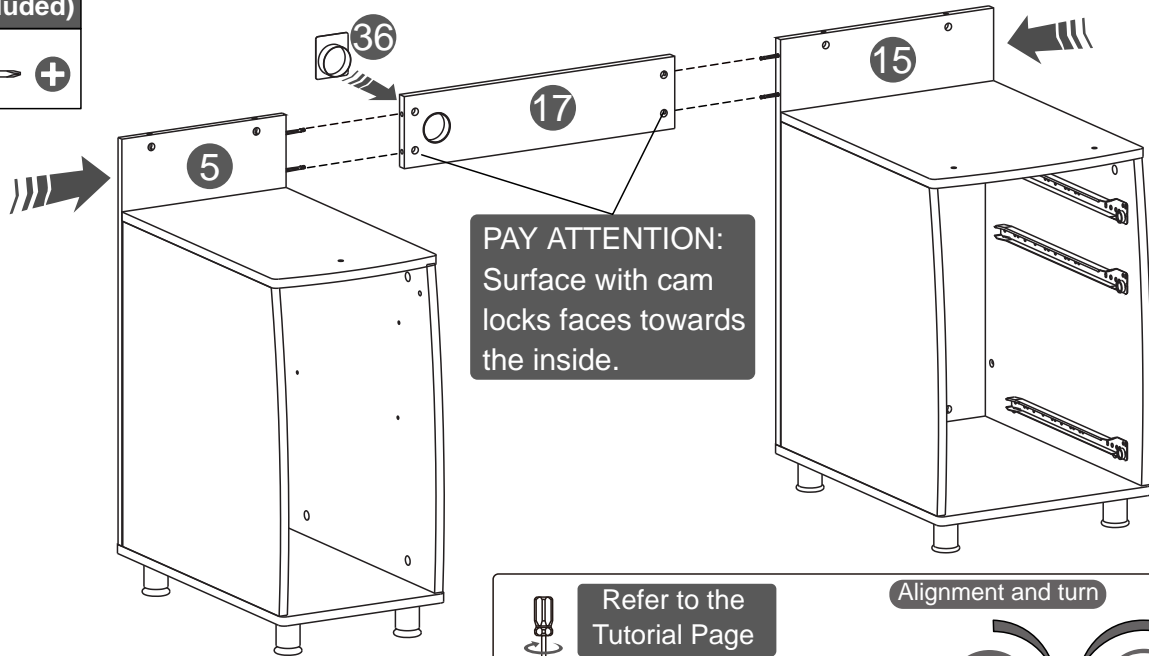

STEP 8

This step requires of 2 people



Hardware

F		12 Pcs
	M4x14	

K		4 Pcs
	M6x25	

Tools (included)



FIRST: Attach K to #18 at the back.

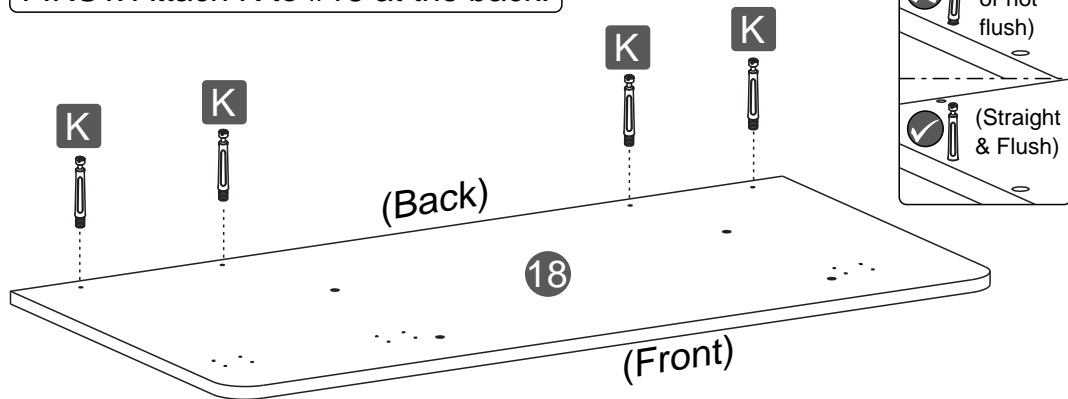

THEN: Attach #19 to #18 with F at the front.

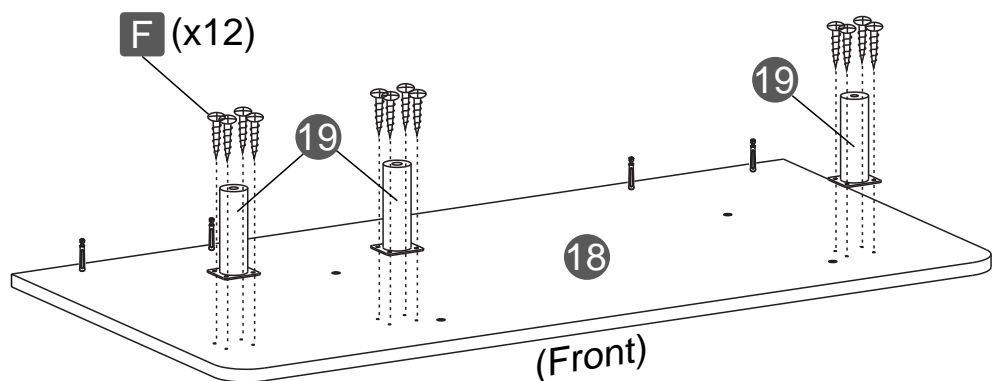

ASSEMBLY STEPS

STEP 9

This step requires of 2 people



Hardware

F	M4x14	4 Pcs
H	M6x12	4 Pcs
I	M4x4	4 Pcs

Tools (included)



FIRST: Attach #21 to #18 with H.

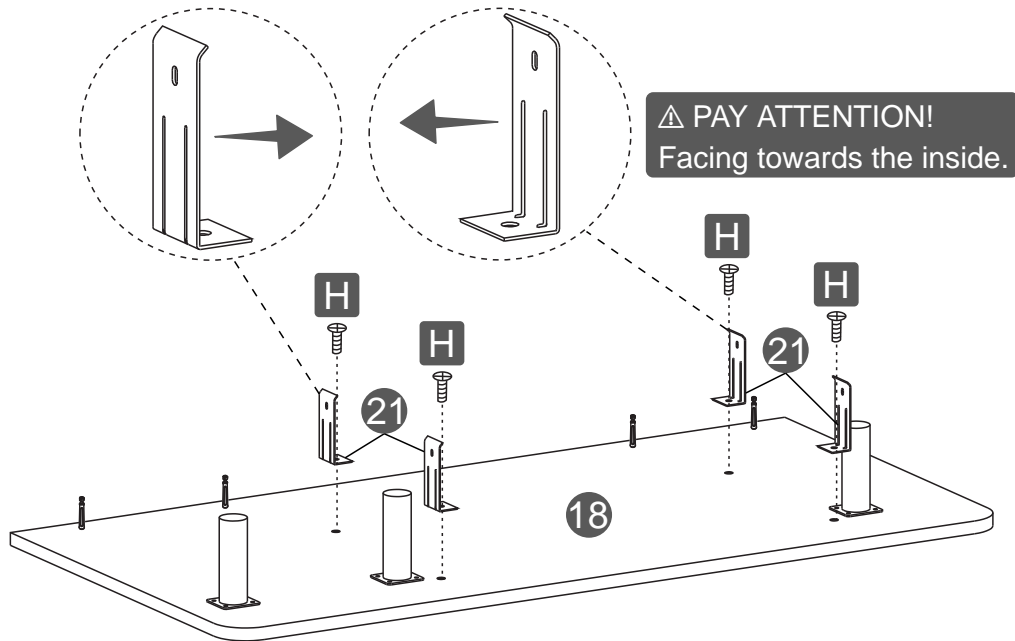

THEN: Attach #20 to #22 with F.

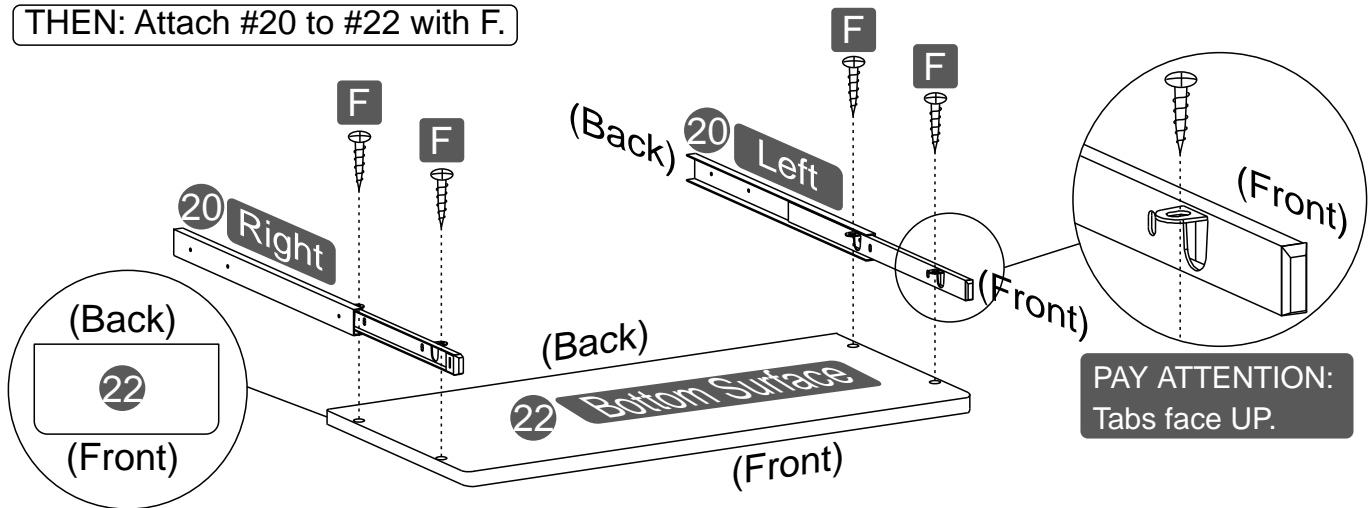

LAST: Attach #20 to #21 with I.

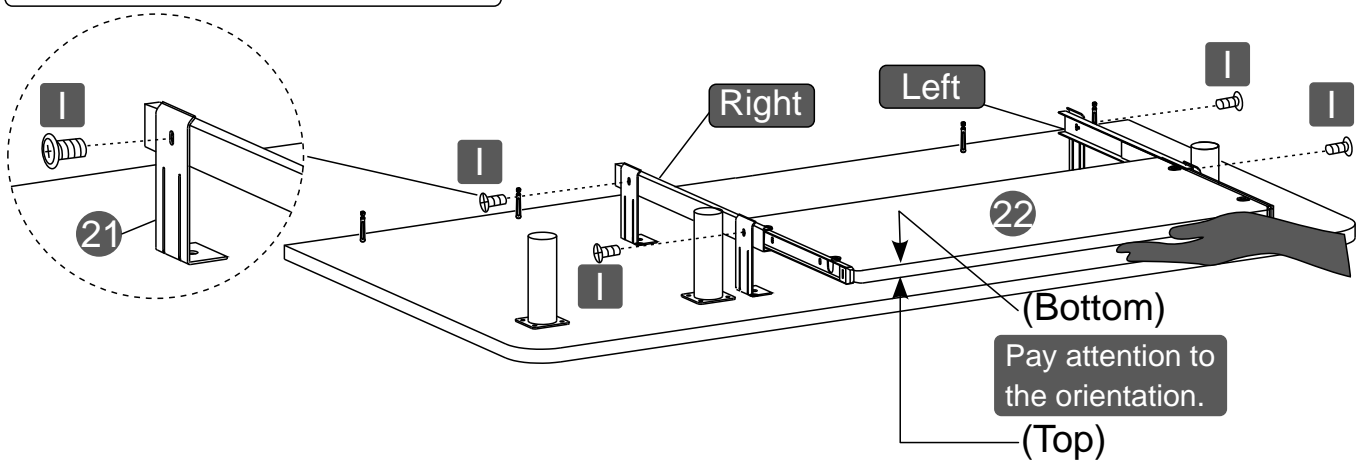



ASSEMBLY STEPS

STEP 10

This step requires of 2 people 

Hardware

A  3
M6x35 Pcs

J  3
M8 x Ø40 x 1.8
Soft plastic washer Pcs

Tools (included)



FIRST: Place J over the front holes on #6 and #16.

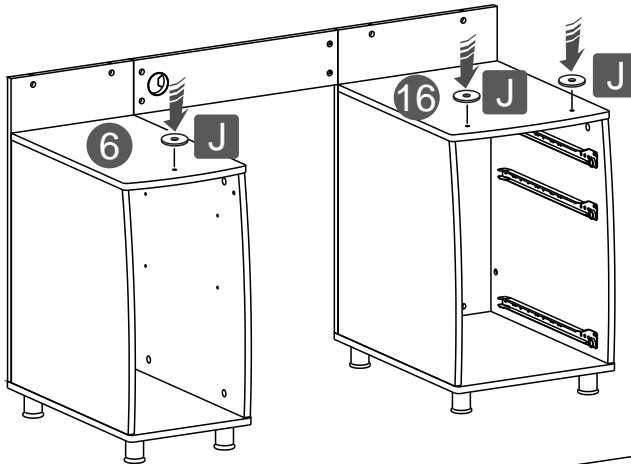

THEN: Carefully place #18 over the frame base.

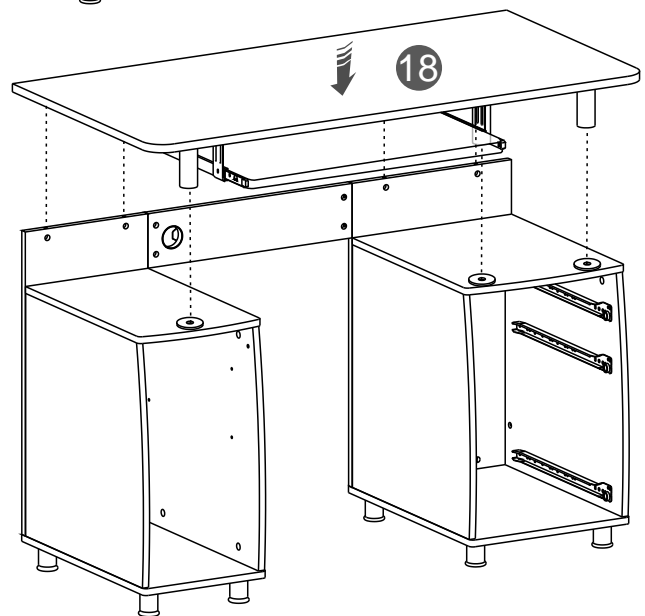

LAST: Secure the tubes #19 to #6 and #16 with A; also secure #5 and #15 to #18 as explained in the TUTORIAL page.

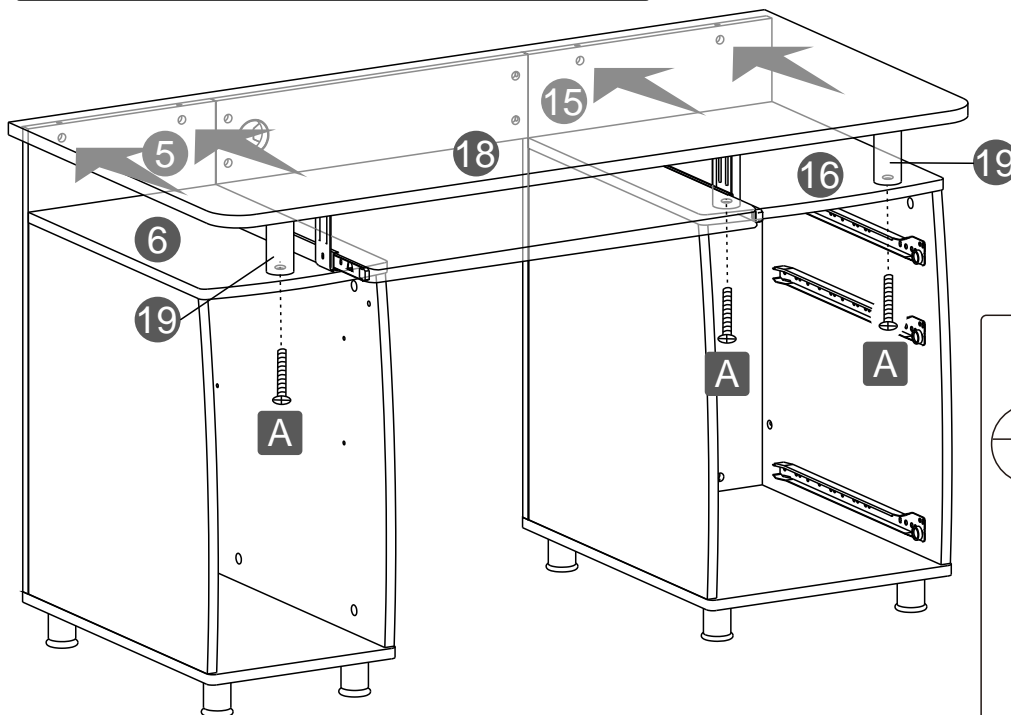

 TIP! Secure the tubes FIRST, then the back panels.

Refer to the Tutorial Page

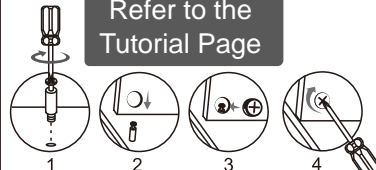

Alignment and turn



ASSEMBLY STEPS

STEP 11

This step requires of 2 people 

Hardware

D  2
M4x20 Pcs

G  8
M4x16 Pcs

Tools (included)

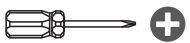

FIRST: Attach #8 to #23 with G.

THEN: Attach #24 to #23 with D.

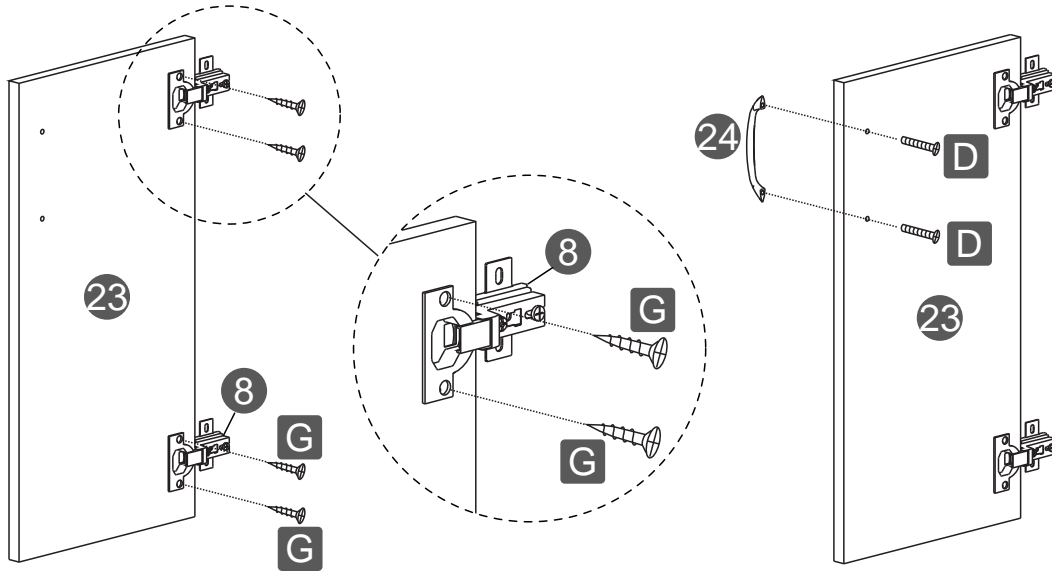

THEN: Attach the hinges #8 from #23 to #1 with G and attach #9 to #2.

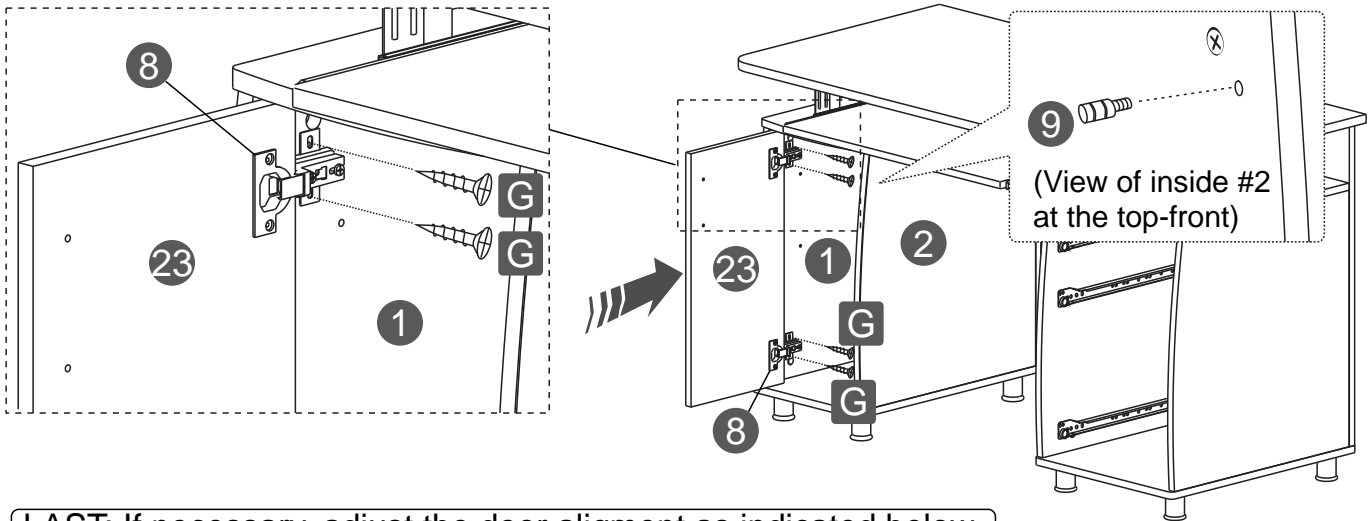

LAST: If necessary, adjust the door alignment as indicated below.

To adjust the door this way:

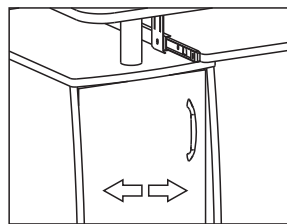

Side-to-side

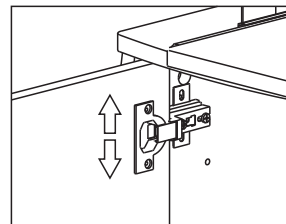

Up-Down

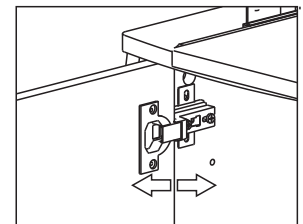

Front-back (Depth)



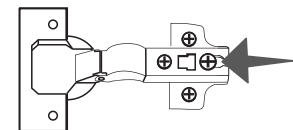
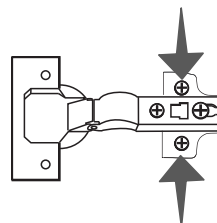
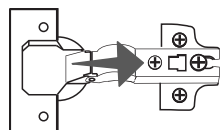

Loosen up these screws, align, and re-tighten:



ASSEMBLY STEPS

STEP 12

Hardware

B		8 Pcs
C		8 Pcs
D		4 Pcs
K		8 Pcs

Tools (included)



FIRST: Attach #25 and #26 to #27 with K.

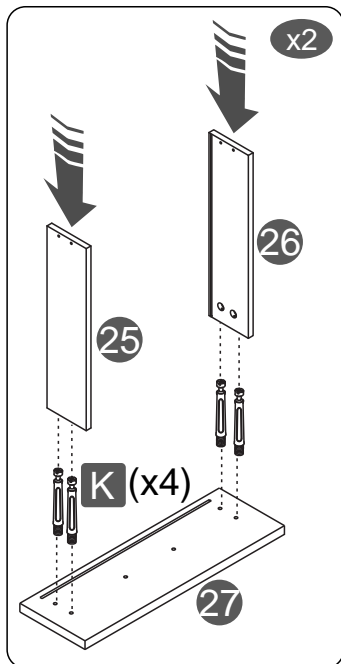

THEN: Slide #28 through #25, #26, and into #27.

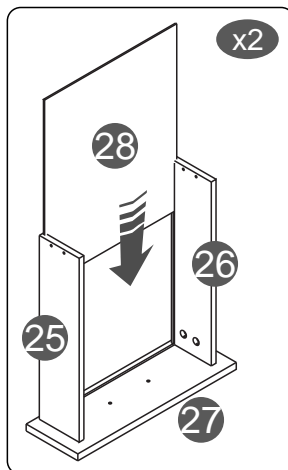

THEN: Attach #29 to #25 and #26 with B.

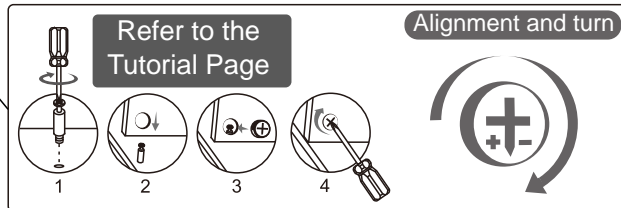
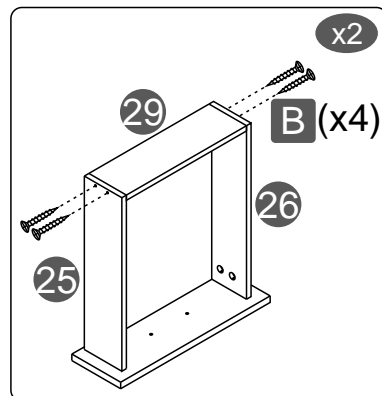

THEN: Attach the "L" shaped sliders #14 to the bottom of the drawer with C.

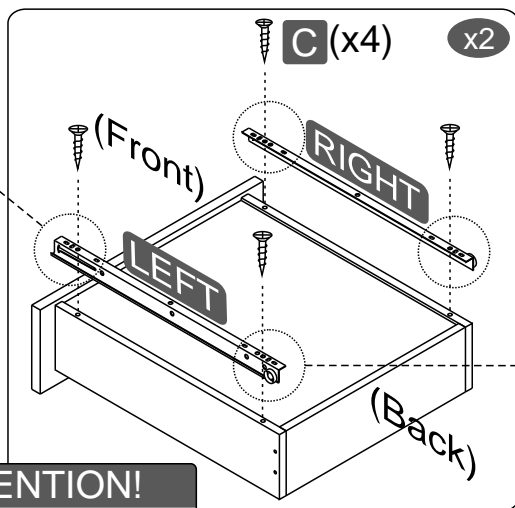
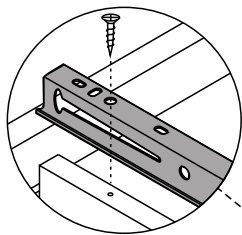

⚠ PAY ATTENTION!

Correct installation:

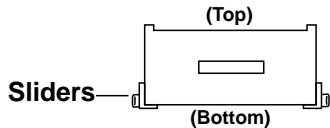

Below installation is WRONG, it will raise the drawer 1" and won't fit in the unit!



Sliders RAISES 1" !!!

LAST: Attach #24 to #27 with D.

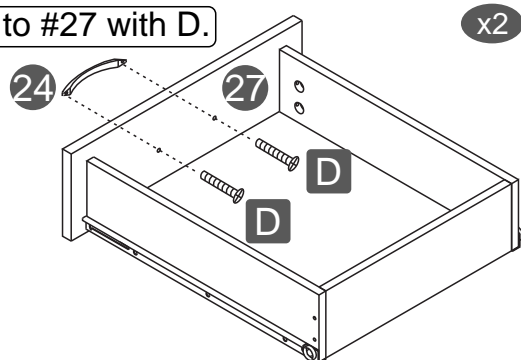

ASSEMBLY STEPS

STEP 13

Hardware

B		4 Pcs
C		4 Pcs
D		2 Pcs
K		4 Pcs

Tools (included)



FIRST: Assemble the file drawer in a similar way like you did before with the small drawers, and as indicated below.

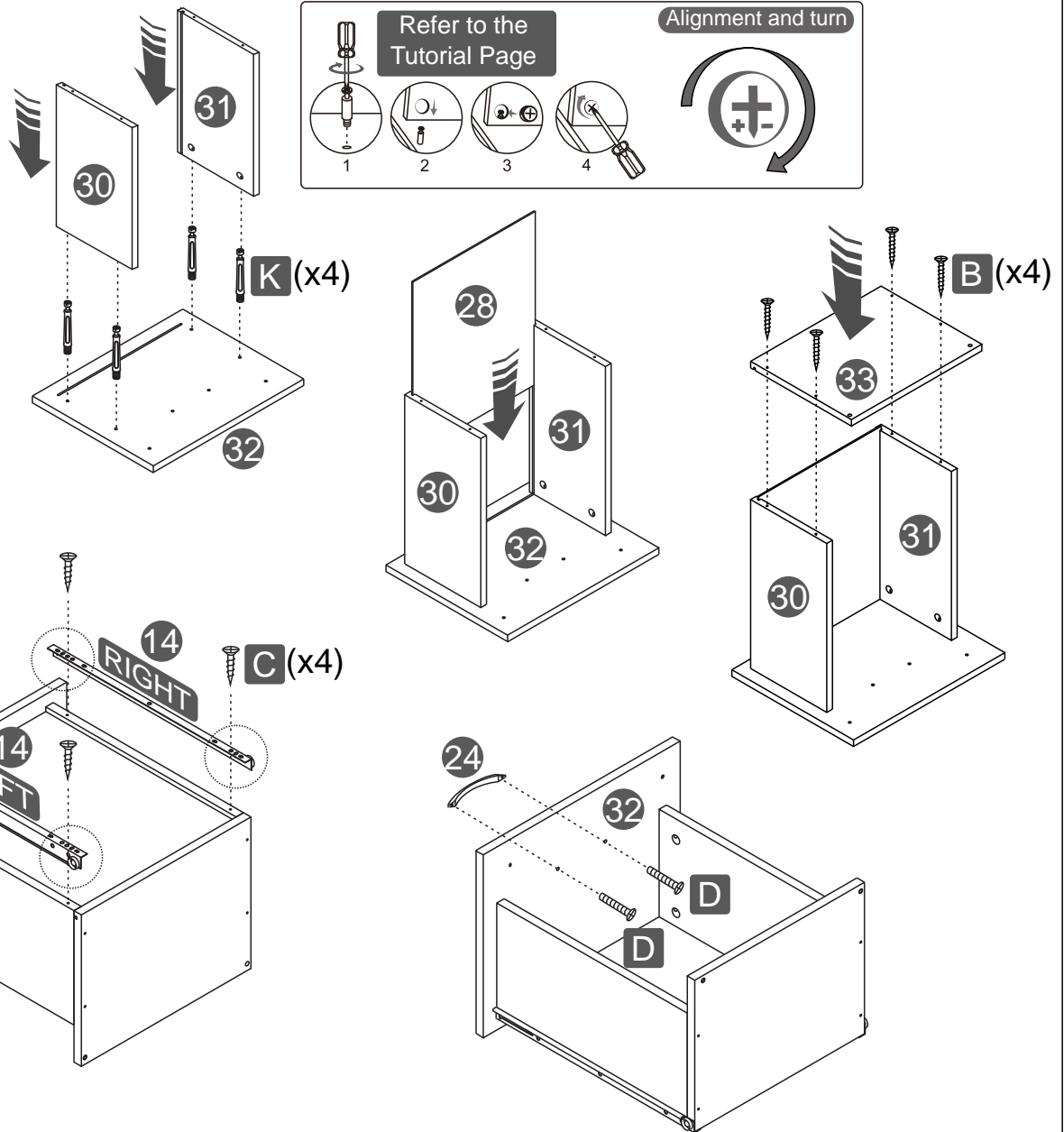

Refer to the Tutorial Page

Alignment and turn

THEN: Insert #34 through #33 and into #32.

⚠ PAY ATTENTION!
Do not overtighten #34 to avoid accidental humps or perforation.
(This kind of damage is not covered by the product's warranty)

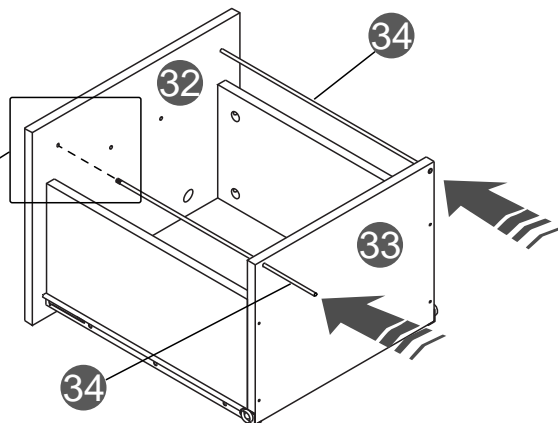

ASSEMBLY STEPS

STEP 14

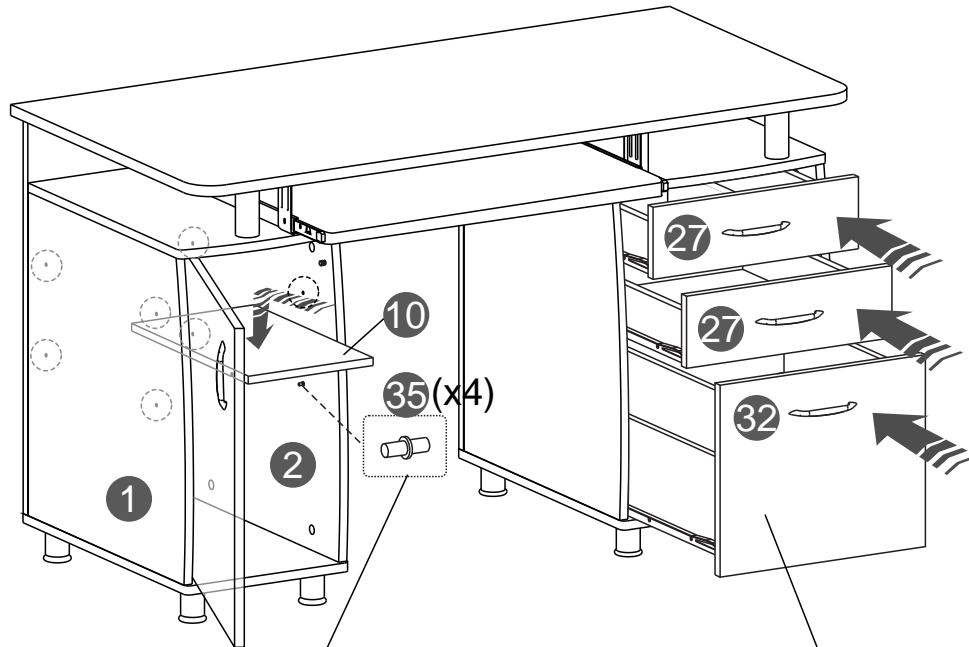

FIRST: Attach #35 into the sets of holes of your preference on #1 and #2 and place #10 over the pins.

FINALLY: Insert the drawers starting with the bottom, then middle, top last.

TROUBLESHOOTING THE DRAWERS

The drawers don't close completely and stop at about 2 inches from closing.

- The sliders inside the cabinet might be installed using the wrong holes. Remove the drawers and review as instructed on steps 3 and 6.
- The screw heads might be protruding and interfering with the wheels. Remove the drawers and re-tighten the screws as flush as possible inside the cabinet and on the drawers.

There is a half inch gap at the bottom of the file drawer, and the top drawer doesn't fit.

- Make sure to insert the drawers with their wheels going and rolling in the middle of the sliders, not on top of them.
- Review the assembly done in steps 3, 6, 12 and 13 to check if the sliders were properly installed.
- Remove the sliders and re-install them correctly following the directions from those steps.

The drawers look very loop-sided.

- Make sure the wheels on the drawers are rolling in the middle of the sliders, not on top of them.
- Check if the correct hole at the front was used (the 3rd hole, not the first, not the second), and if not, remove the slider and re-attach correctly.
- The pre-drilled hole at the front might be little higher or lower than the other side. To correct this, remove the screw, move the slider just mere milimeters up or down according to the situation, and use the same screw to re-attach using this time the second hole. You will have to force the screw into the wood since there is no pre-drilled hole on the new spot.

There are gaps of less than a quarter of an inch in between any of the drawers.

This is normal and should not be considered a defect. The item not always will be 100% perfect, and these kind of small imperfections should not affect the product in any way to the point that will prevent its use as intended.

WARNINGS

Not paying attention to the following warnings could result in injuries.

WEIGHT LIMITS - DO NOT EXCEED

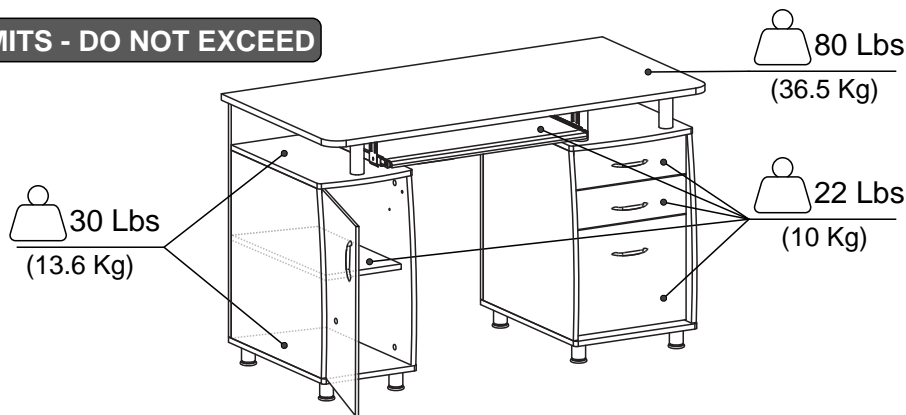

- Do not sit, climb or stand on the Unit.
- Do not allow children to play over, under, or inside the unit.

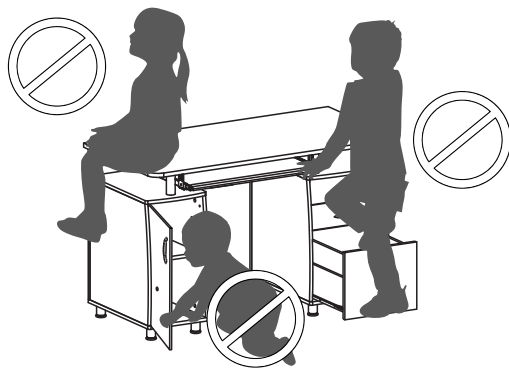

- 2 persons are required for moving the unit at distances longer than 2 feet.
- Remove or secure any objects that are heavy or might fall off during moving.
- Lift by bending your knees, not your backs.

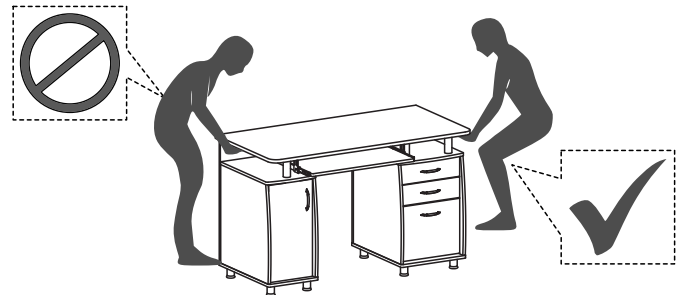

CARE AND MAINTENANCE

- Clean with a cloth lightly damped in a solution of mild soap and water.
- Do not use solvents or abrasive materials.



Do not expose to direct sunlight or extreme environmental conditions.

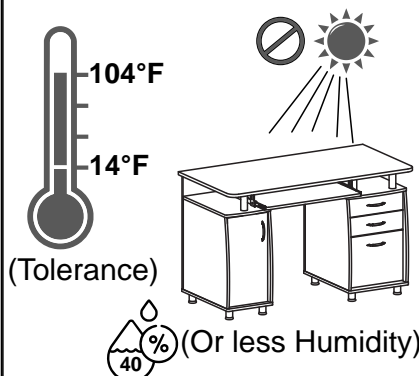

Inspect and re-tighten any loose screws every 4 months.

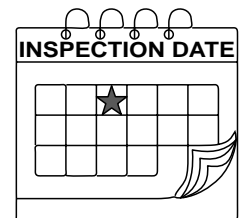

LIMITED WARRANTY



For details, please visit our website:
Technimobili.com

To file a claim or request information, please email to:
warranty@rtaproducts.com

