

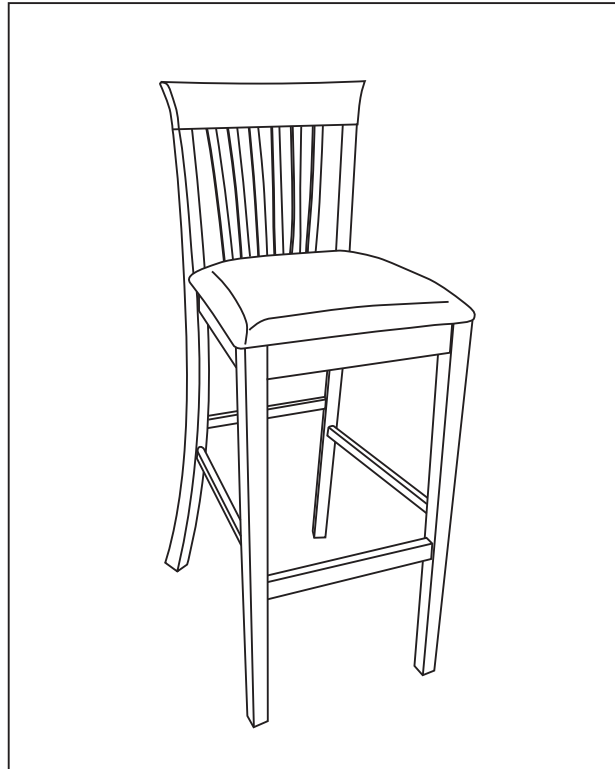

LINON HOME DECOR PRODUCTS, INC.

ASSEMBLY INSTRUCTIONS
TORINO COLLECTION CRAFTSMAN BAR STOOL



We are here to help!

We do our best to insure that your furniture arrives in excellent condition. In the event that a part is damaged or missing, Linon Home Decor will be happy to provide you with replacement parts, at no charge, within 30 days of purchase, providing the parts are available in our warehouse and the item purchased is part of our current inventory. In order to receive spare parts, at no charge, you must provide proof of purchase within 30 days.

If you need assistance with assembly or replacement parts, please call Linon Customer Service, prior to returning the item to the store.

Our office is open Monday – Friday 9AM – 5PM, Eastern Standard Time.

Our toll free customer service number is: 1-800-262-1852.

Or visit our web site www.Linon.com to order spare parts and for care instructions on your newly purchased furniture.

MADE IN VIETNAM
FOR LINON HOME DECOR PRODUCTS INC BY **V1**



LINON HOME DECOR PRODUCTS, INC.

Parts Identification

ITEM	DESCRIPTION	QTY
#1	ASSEMBLED SEAT BACK	01
#2	SEAT FRAME	01
#3	SEAT CUSHION	01
#4	RIGHT FRONT LEG	01
#5	LEFT FRONT LEG	01
#6	RIGHT SIDE STRETCHER	01
#7	LEFT SIDE STRETCHER	01
#8	FRONT STRETCHER	01

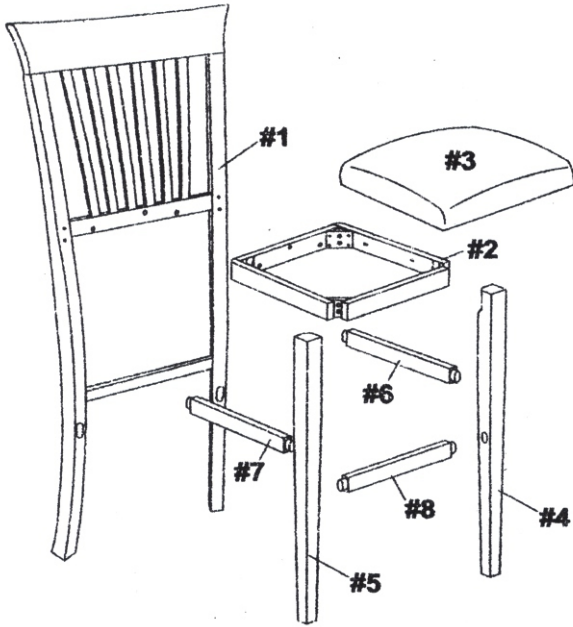

For ease of identification all parts are labeled to correspond to the Step number in which the part is used.







If any parts are missing or damaged in this package, Linon Home Decor will be happy to provide you with replacement parts, at no charge, within 30 days of purchase, providing the parts are available in our warehouse and the item purchased is part of our current inventory. In order to receive spare parts, at no charge, you must provide proof of purchase within 30 days.

Call us toll free at 1-800-262-1852. Or visit our web site www.Linon.com to order spare parts and for care instructions on your newly purchased furniture.

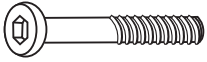
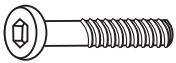

LINON HOME DECOR PRODUCTS, INC.

Hardware Identification

ITEM	PICTURE	DESCRIPTION	QTY
A	 (Ø1/4"x85mm)	BACK LEG BOLT	04
B	 (Ø1/4"x60mm)	FRONT LEG BOLT	04
C	 (Ø1/4"x50mm)	BACK RAIL BOLT	03
D	 (Ø4mmx45mm)	LONG SCREW	06
E	 (Ø4mmx30mm)	SHORT SCREW	05
F	 (Ø8mmxØ18mm)	FLAT WASHER	11
G	 (Ø8mmxØ13mm)	SPRING WASHER	11
H		HEXAGONAL WRENCH	01

If any parts are missing or damaged in this package, Linon Home Decor will be happy to provide you with replacement parts, at no charge, within 30 days of purchase, providing the parts are available in our warehouse and the item purchased is part of our current inventory. In order to receive spare parts, at no charge, you must provide proof of purchase within 30 days.

Call us toll free at 1-800-262-1852. Or visit our web site www.Linon.com to order spare parts and for care instructions on your newly purchased furniture.



LINON HOME DECOR PRODUCTS, INC.

STEP 1.

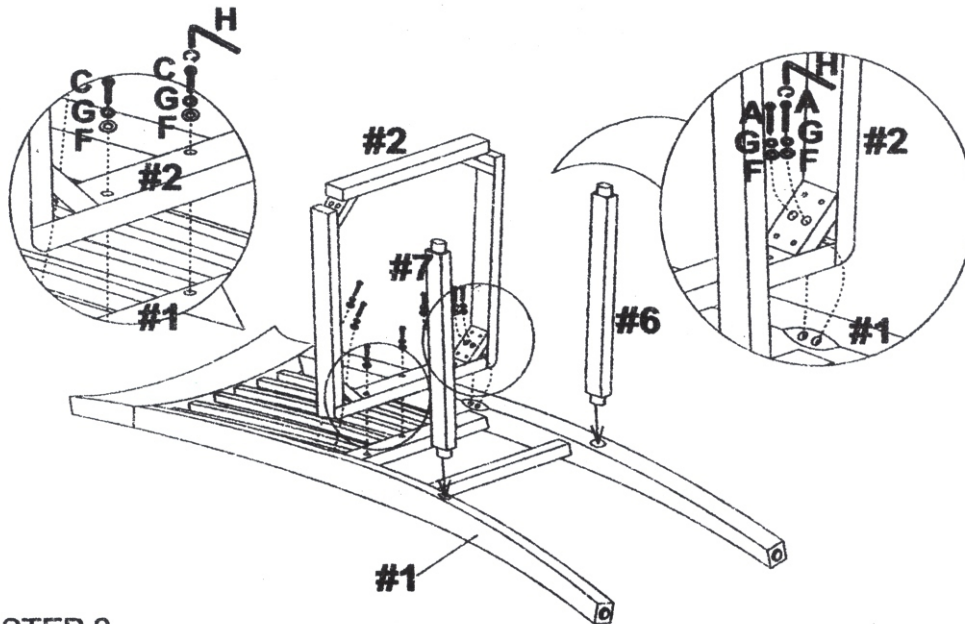

STEP 2.

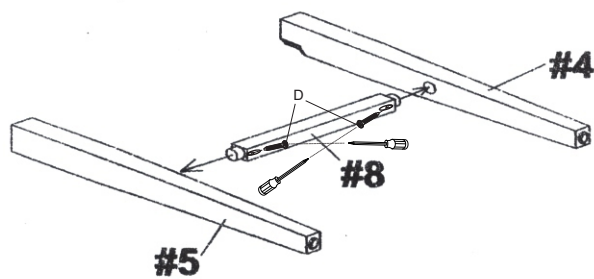

IMPORTANT: DO NOT TIGHTEN COMPLETELY ANY BOLT UNTIL ALL LINED-UP BOLTS ARE CONNECTED TO INSERTED NUTS.

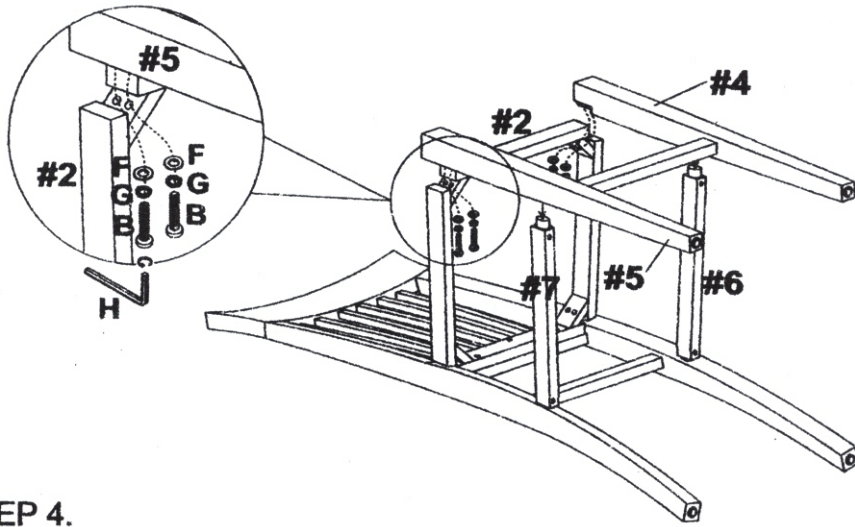

STEP 4.

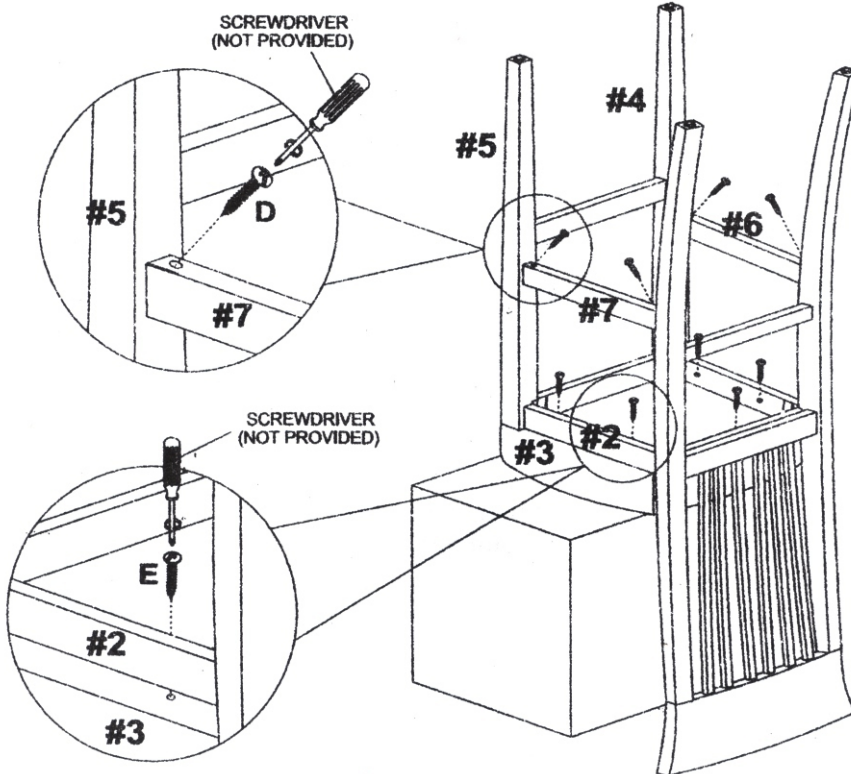



LINON HOME DECOR PRODUCTS, INC.

LIMITED 6 MONTHS WARRANTY

WHAT IS COVERED

This product is covered under our manufacturer's 6 months limited warranty (Linon Home Decor Products). To ensure your complete satisfaction, this warrants to the original purchaser that the Linon supplied item is free from defects in material and workmanship, as of the date of purchase, and that it will, under normal use and proper care, remain so for six months after the date of purchase.

Replacement of missing or initially defective parts will be sent, at no charge, for a period of 30 days from the date of purchase with valid proof of purchase providing the parts are available in our warehouse and the item purchased is part of our current inventory.

Attention: This chair is designed for household use only and not for commercial use. This chair maximum weight load limited to 275lbs. Do not stand on the chair.

WHAT IS NOT COVERED

It remains the customer's responsibility for freight and packaging charges to and from the customer service center. Labor and material charges to remove or replace parts under this warranty are not covered.

This warranty does not cover furniture used for commercial purposes, failures caused by improper care, unreasonable or abusive use, freeze damage, acts of God, rust, purchased parts or return freight and packaging charges. Proof of purchase (dated register receipt) is required for warranty claims.

HOW TO OBTAIN SERVICE

For further information, please contact our customer service department, c/o Linon Home Decor Products, Inc., between 9:00 AM and 5:00 PM Eastern Standard Time, Monday through Friday:

LINON HOME DECOR PRODUCTS, INC.,
CUSTOMER SERVICE DEPARTMENT
22 JERICHO TURNPIKE
MINEOLA, N.Y. 11501

Toll free number : 1 - 800 - 262 - 1852 Customer Service
Visit our web site www.Linon.com to order replacements parts and for care instructions on your newly purchased furniture.