

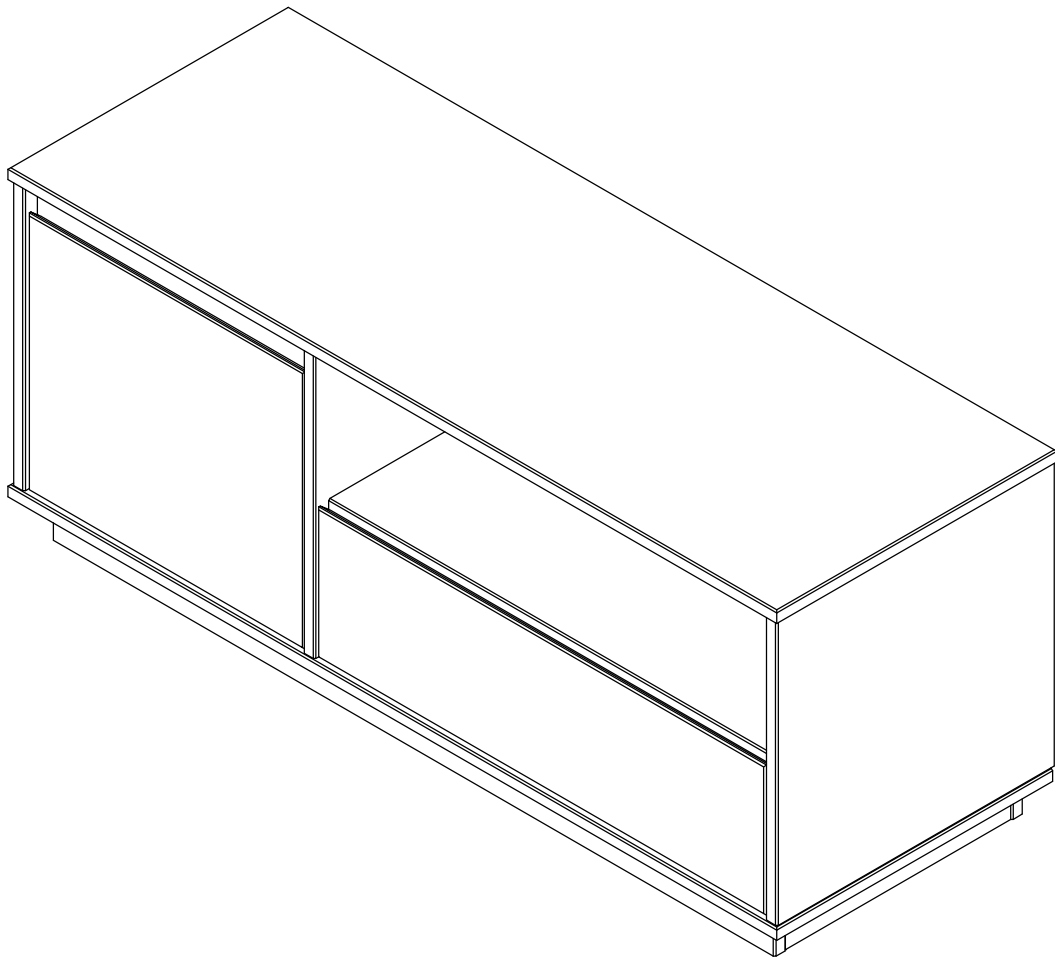

LINON HOME DECOR PRODUCTS, INC.

MAXTON MID CENTURY RACK 1 DOOR 1 DRAWER
MAXTON MID CENTURY MEUBLE TV 1 PORTE 1
TIROIR
MAXTON MID CENTURY RACK 1 PUERTA 1 CAJÓN



BR12 - 20451



We are here to help! Before you return it - contact us.

We do our best insure that your furniture arrives in excellent condition. In the event that a part is damaged or missing, Linon will be happy to provide you with replacement parts, at no charge, within 30 days of purchase, providing the parts are available in our warehouse and the item purchased is part of our current inventory. In order to receive spare parts, at no charge, you must provide proof of purchase within 30 days.

If you need assistance with assembly or replacement parts, please call Linon Customer Service, prior to returning the item to the store.

- Our office is open Monday - Friday 9am - 5pm, Eastern Standard Time.
- Our toll free customer service number is: 1- 800 - 262 - 1852.
- Or visit our web site www.linon.com to order spare and for care instructions on your newly purchased furniture.

Nous sommes là pour vous aider! Avant de retourner le produit, veuillez communiquer avec nous.

Nous faisons tout en notre pouvoir pour que vous receviez votre meuble en parfait état. Toutefois, si une pièce est endommagée ou manquante, Linon se fait un plaisir de vous envoyer gratuitement la pièce de rechange, dans les 30 jours suivant l'achat, à condition que nous ayons la pièce en stock et que le produit acheté fasse partie de notre inventaire courant. Afin de recevoir gratuitement la pièce de rechange, vous devez fournir une preuve d'achat dans un délai de 30 jours.

Si vous avez besoin d'une pièce de rechange ou d'aide pour l'assemblage, veuillez communiquer avec le service à la clientèle de Linon avant de retourner le produit au magasin.

- Nos bureaux sont ouverts du lundi au vendredi, de 9h à 17 h, heure normale de l'Est.
- Le numéro sans frais pour joindre notre service à la clientèle est le 1 - 800 - 262 - 1852.
- Vous pouvez aussi visiter notre site web à www.linon.com pour commander des pièces de rechange et pour obtenir les instructions d'entretien de votre nouveau meuble.

¡Estamos aquí para ayudarle! Antes de regresar el producto, comuníquese con nosotros.

Hacemos todo lo posible para que su mobiliario se le entregue en excelentes condiciones. En caso de que falte una pieza o esté dañada, Linon le enviará con gusto la pieza de repuesto sin ningún costo dentro de los 30 días posteriores a la compra, siempre y cuando tengamos en existencia las piezas en nuestros almacenes y que el artículo comprado forme parte de nuestro inventario actual. Para recibir piezas de repuesto, sin costo adicional, debe enviarnos el comprobante de compra dentro de los 30 días después de la compra.

Si necesita ayuda para ensamblar su producto o para obtener piezas de repuesto, llame al Servicio al Cliente de Linon antes de devolver el artículo a la tienda.

- Nuestras oficinas están abiertas de Lunes a Viernes de las 9.00 a las 17.00 horas, hora del Este.
- Número de servicio al cliente gratuito: 1 - 800 - 262 - 1852.
- Para pedir piezas de repuesto y consultar las instrucciones de cuidados de su mueble recién adquirido, visite nuestro sitio www.linon.com.



LINON HOME DECOR PRODUCTS, INC.



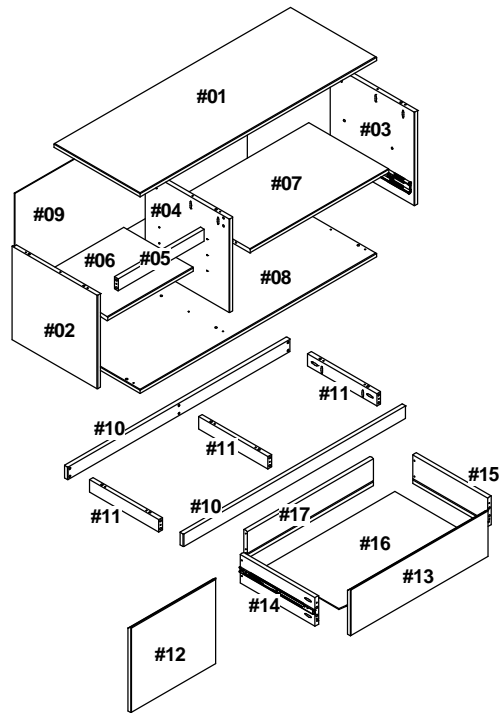

Part list / Liste des pièces / Lista de piezas



Part Number	Description	Qty.
826432WAL - 01 - BR12	Top panel / Panneau supérieur / Panel superior	01
826432WAL - 02 - BR12	Left panel / Panneau gauche / Panel izquierdo	01
826432WAL - 03 - BR12	Right panel / Panneau droite / Panel derecho	01
826432WAL - 04 - BR12	Division / Diviseur / Divisor	01
826432WAL - 05 - BR12	Upper rail / Rail supérieur / Riel superior	01
826432WAL - 06 - BR12	Adjustable Shelf / Étagère réglable / Repisa Ajustable	01
826432WAL - 07 - BR12	Fixed shelf / Étagère fixe / Repisa fija	01
826432WAL - 08 - BR12	Bottom panel / Panneau du bas / Panel inferior	01
826432WAL - 09 - BR12	Back panel / Panneau arrière / Panel trasero	01
826432WAL - 10 - BR12	Front back bottom rail / Rail inférieur avant arrière / Riel inferior delantero trasero	02
826432WAL - 11 - BR12	Side bottom rail / Rail inférieur lateral / Riel inferior lateral	03
826432WAL - 12 - BR12	Door / Porte / Puerta	01
826432WAL - 13 - BR12	Drawer front / Avant pour droit / Frente del cajón	01
826432WAL - 14 - BR12	Drawer left panel / Coté gauche du tiroir / Lado izquierdo del cajón	01
826432WAL - 15 - BR12	Drawer right panel / Cté droit du tiroir / Lado derecho del cajón	01
826432WAL - 16 - BR12	Drawer bottom panel / Panneau inférieur pour tiroir / Inferior del cajón	01
826432WAL - 17 - BR12	Drawer back panel / Panneau arrière pour tiroir / Trasero del cajón	01
826432WAL - 00 - BR12	Hardware pack / Ferrures / Paquete de herraje	01

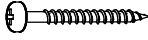
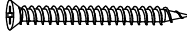

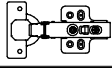
Hardware list / Liste des ferrures / Lista de herraje

A	Wood dowel (8x30) / Goujons de bois / Tarugo de madeira		42
B	Screw (3,5x30mm) / Vis / Tornillo		35
C	Screw (3,5x35mm) / Vis / Tornillo		09
D	Shelf support / Support D'étagère / Soporte de estantes		04
E	Soft close hinge / Charnière à fermeture douce / Bisagra de cierre suave		02
F	Screw (3,5x12mm) / Vis / Tornillo		08
G	Nail / Clou / Clavo		16

Tools required / Outils requis / Herramientas requeridas

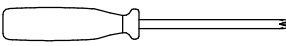
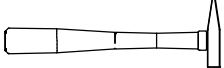
Philips screwdriver / Tournevis Philips / Destornillador estándar		Not supplied / Non fourni / No incluido
Hammer / Marteau / Martillo		Not supplied / Non fourni / No incluido

IMPORTANT:

1. Do not tighten bolts completely until all bolts are completely lined up and inserted into holes / nuts.
2. Do not over tighten screws and bolts to avoid stripping.
3. Please use hand tools to assemble this product. Do not use power tools.

IMPORTANT:

1. Ne serrez pas complètement les boulons jusqu'à ce que tous les boulons soient complètement alignés et insérés dans les trous / écrous.
2. Ne pas trop serrer les vis et les boulons pour éviter d'endommager les filets.
3. Utilisez des outils à main pour assembler ce produit. N' utilisez pas d'outils électriques.

IMPORTANTE:

1. No apriete completamente los pernos hasta que todos los tornillos estén alineados completamente y se inserten en los agujeros / tuercas.
2. No apriete demasiado los tornillos y los pernos para evitar dañar los filetes.
3. Utilice herramientas de mano para montar este producto. No utilice herramientas eléctricas.

USE / MANTINENCE

1. Indoor use only.
2. Wipe clean with damp cloth.

UTILISER / MAINTENANCE

1. Doit être utilisé à l'intérieur seulement.
2. Nettoyez avec un linge humide.

USO / MANTENIMIENTO

1. Solamente usar en espacios internos.
2. Limpiar con un trapo húmedo.



1.

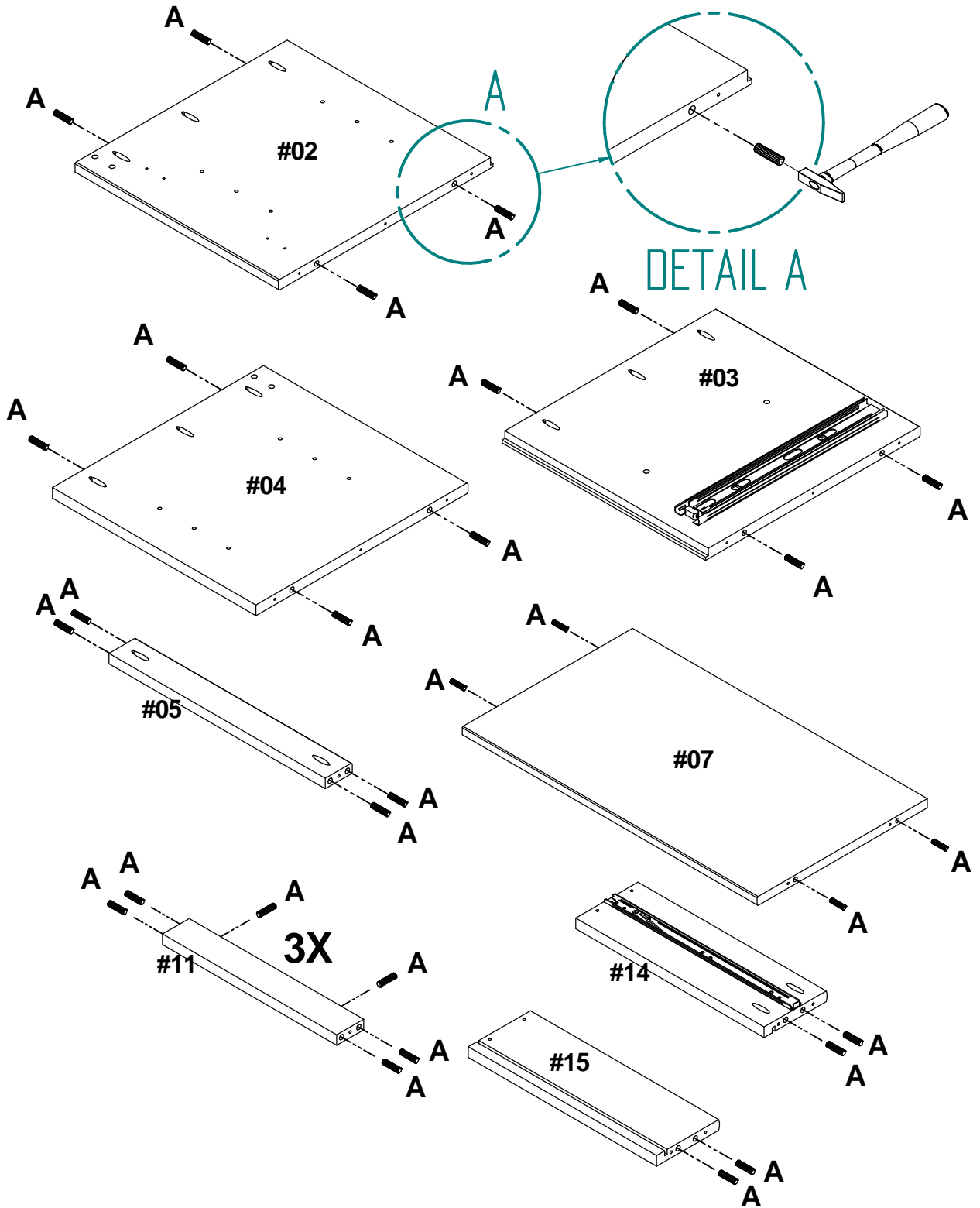

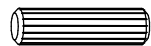
A		42
---	---	----



2.

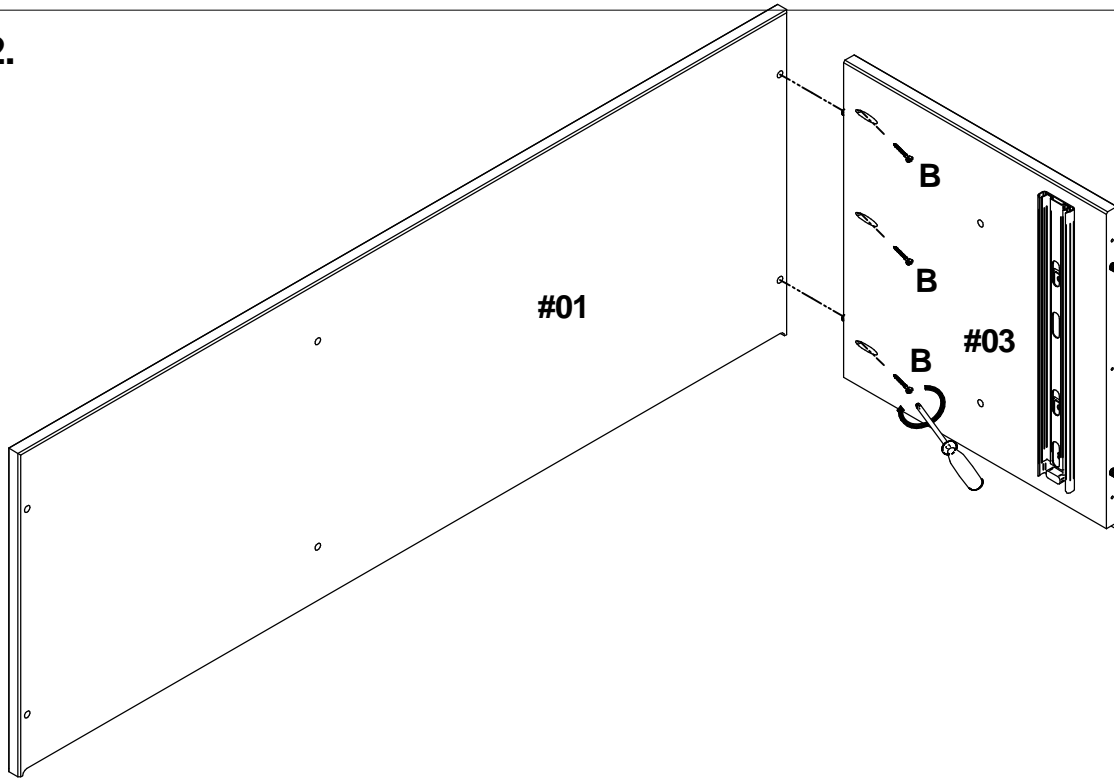

B		03
---	---	----

3.

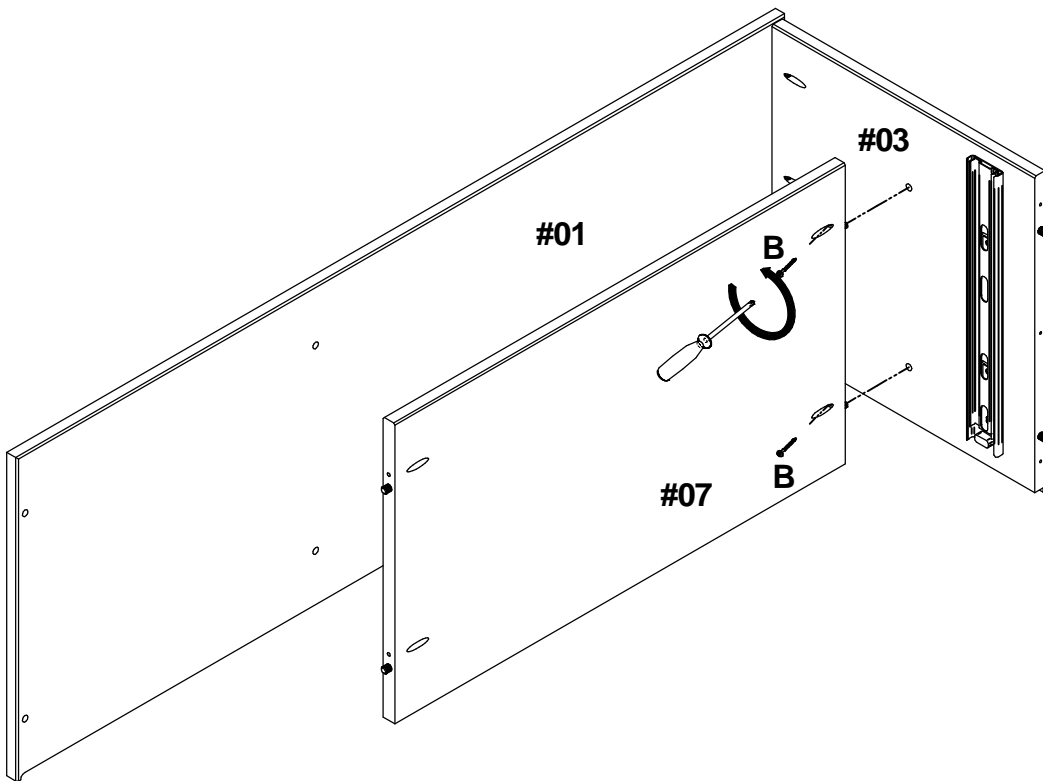

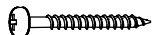
B		02
---	---	----



4.

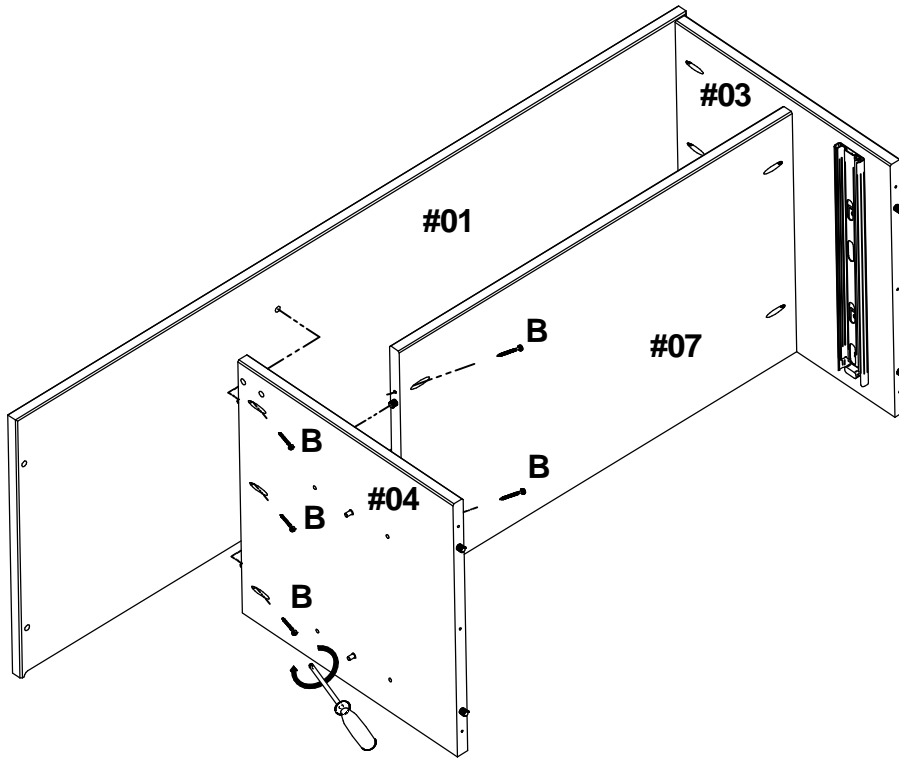

B		05
---	---	----

5.

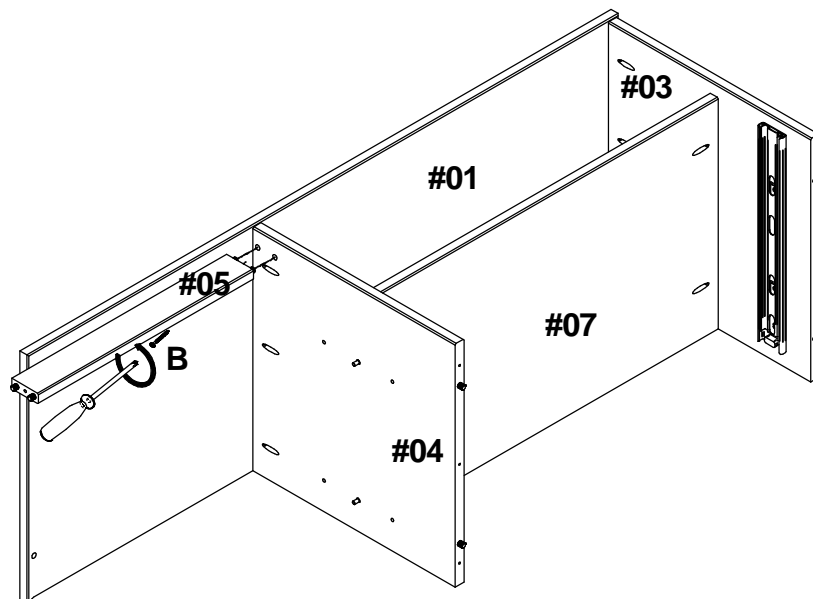

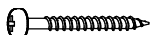
B		01
---	---	----



6.

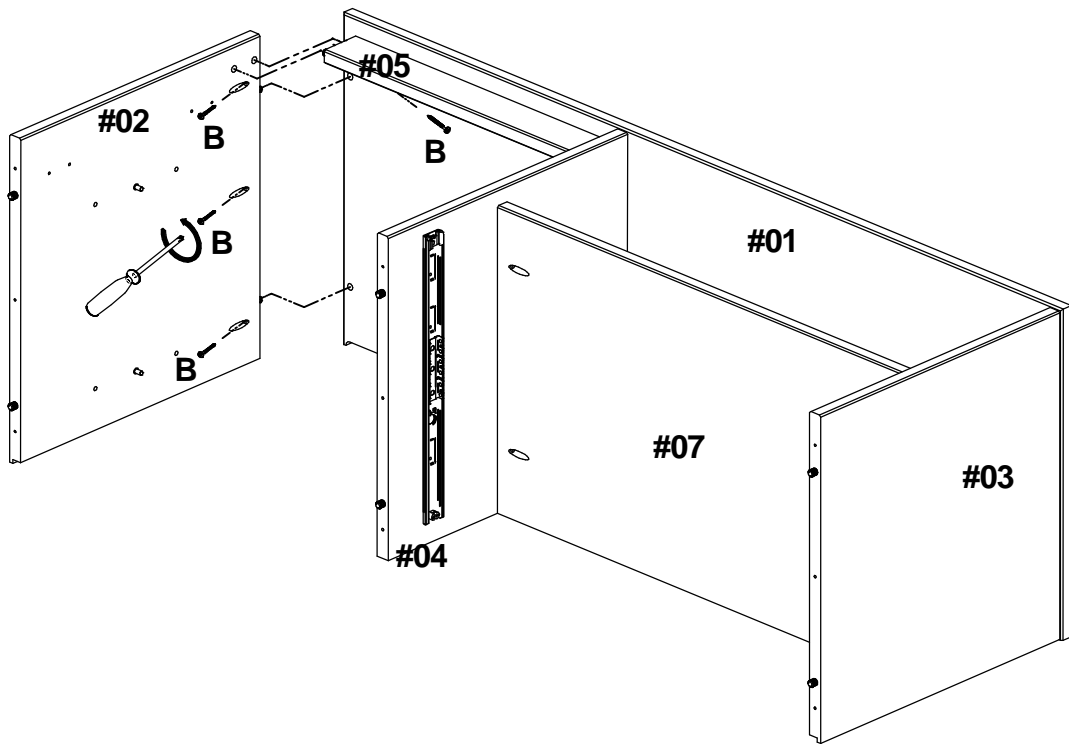

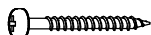
B		04
---	---	----



7.

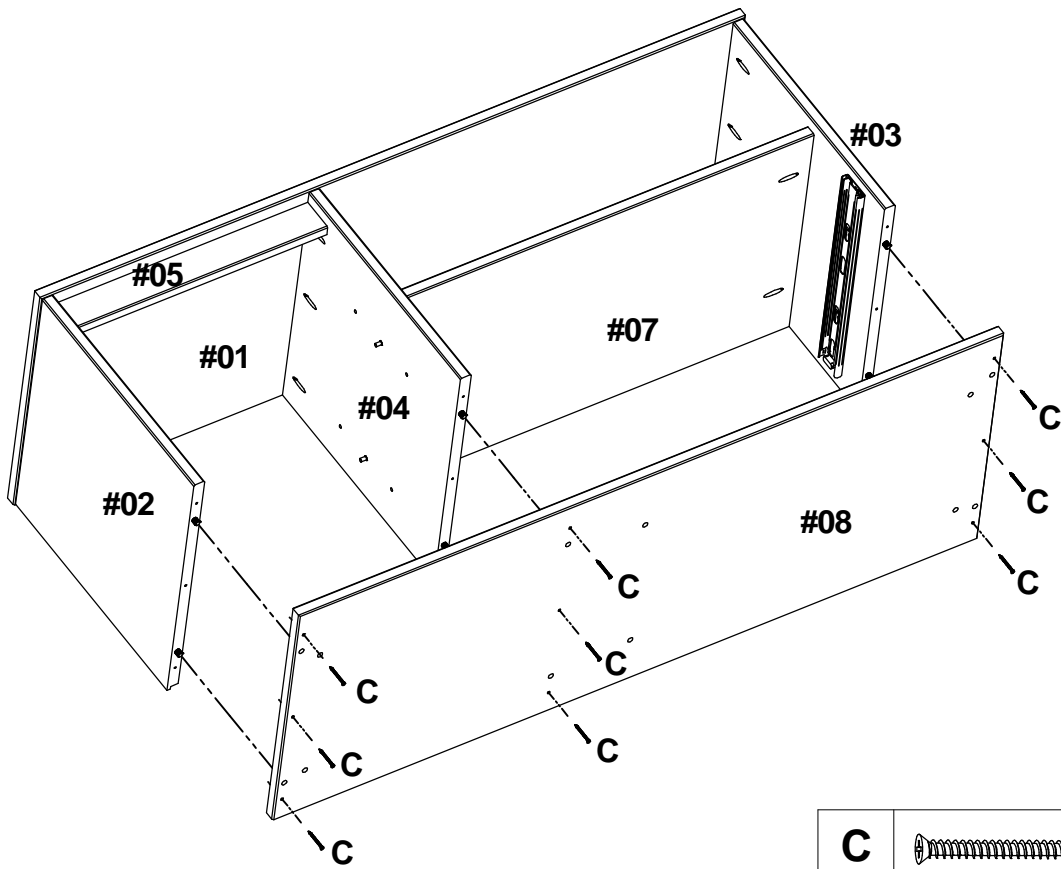

C		09
---	--	----

8.

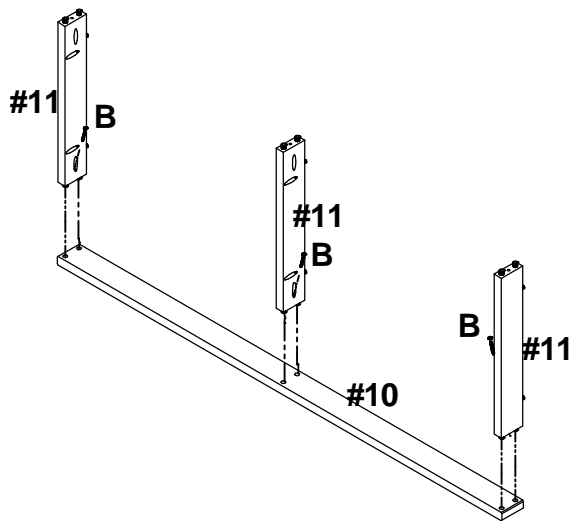

B		03
---	--	----

9.

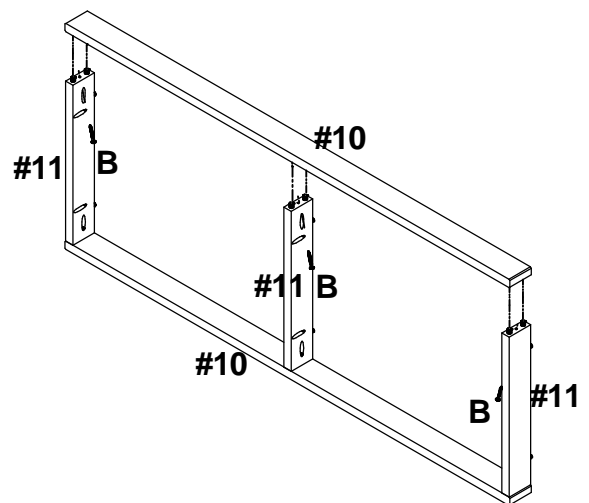

B		03
---	--	----



10.

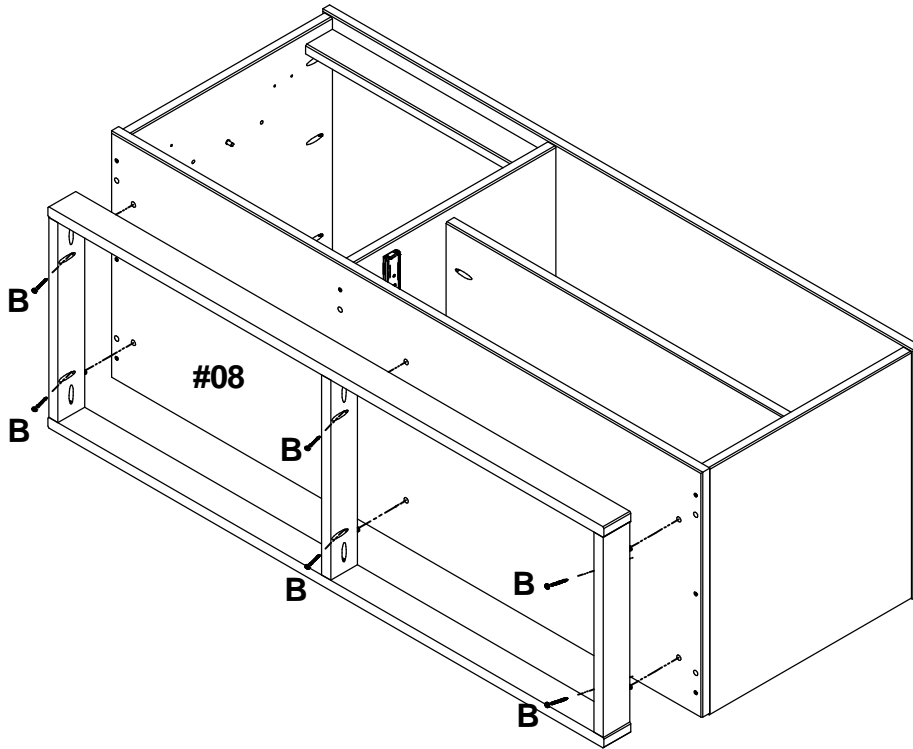

B		06
---	---	----

11.

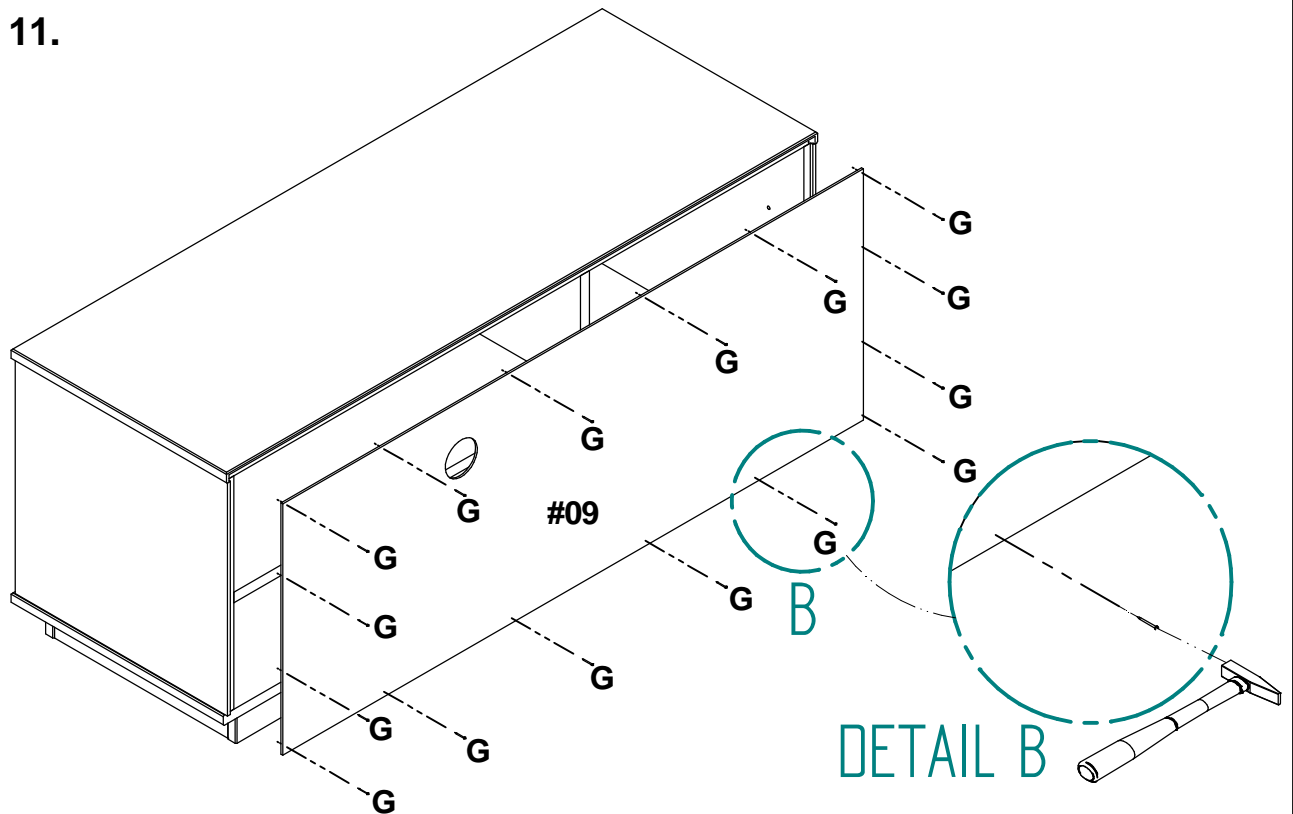

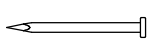
G		16
---	---	----



12.

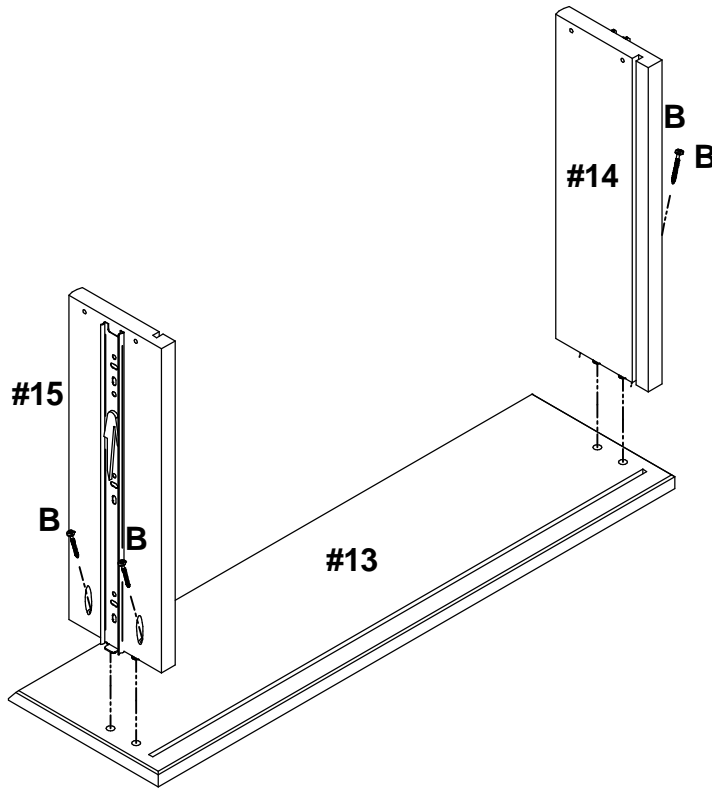

B		04
---	---	----

13.

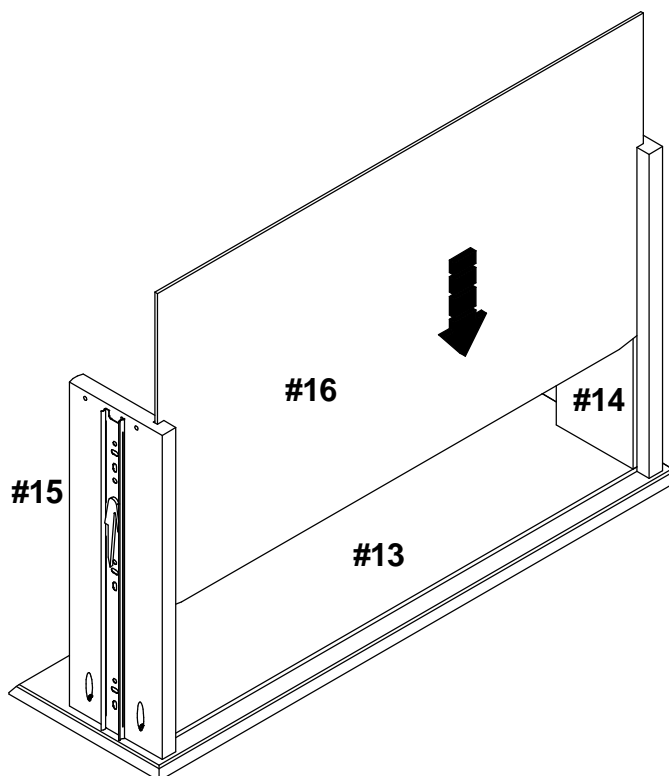



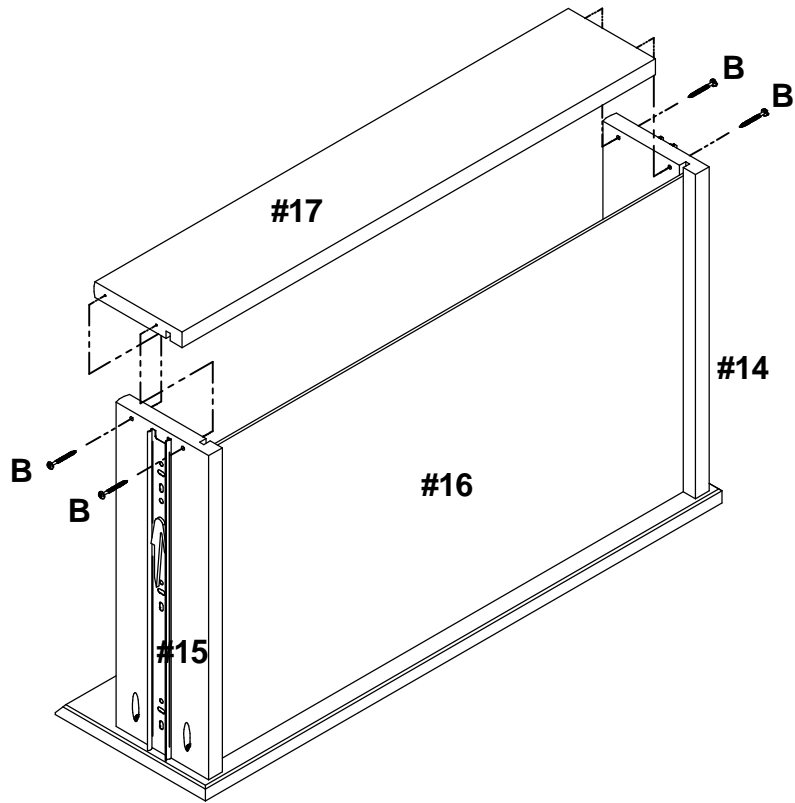

14.

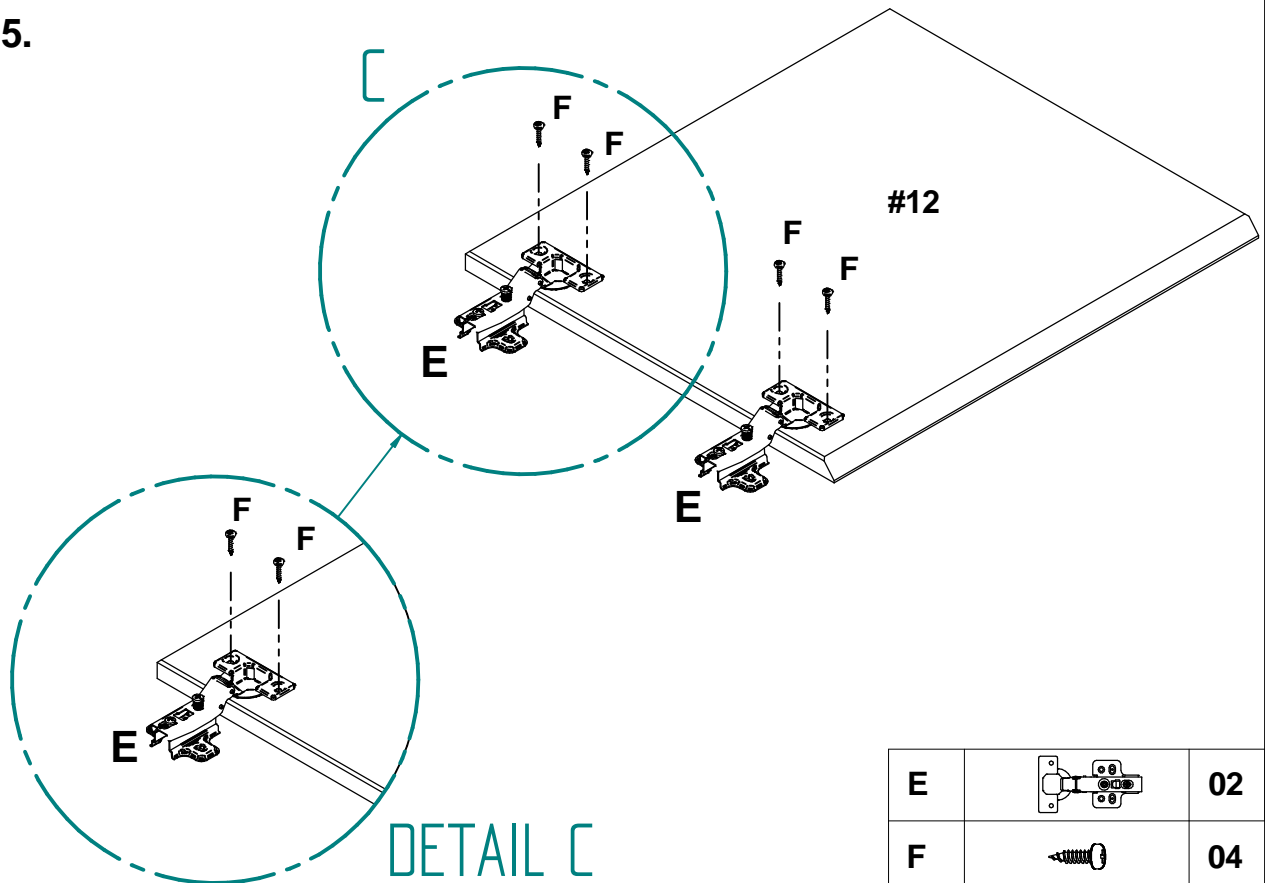

B		04
---	---	----

15.

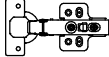

E		02
F		04



16.

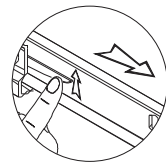
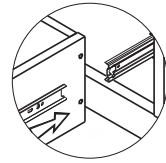

How to fit the drawers
Comment monter les tiroirs
Como montar los cajones

How to take out the drawers
Comment sortir les tiroirs
Como sacar los cajones

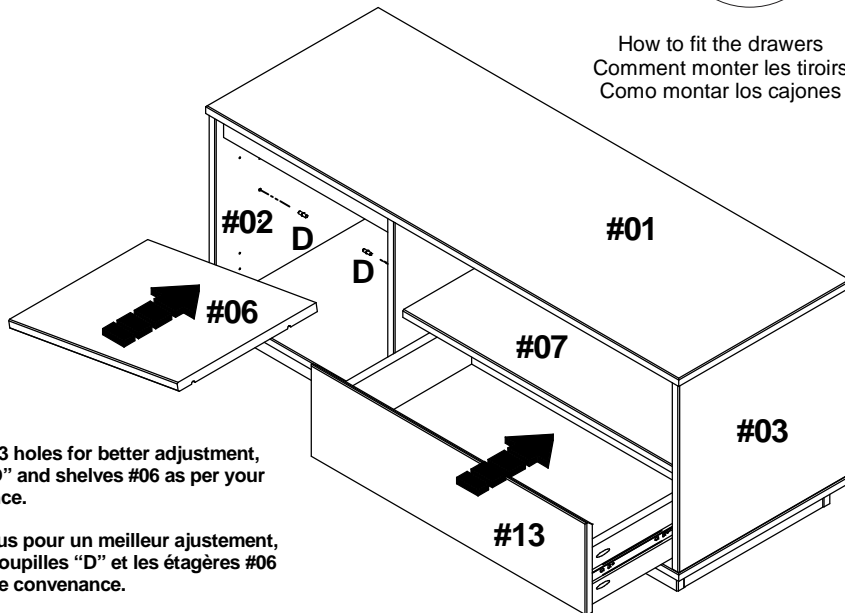

There are 3 holes for better adjustment, fix pins "D" and shelves #06 as per your convenience.

Il y a 3 trous pour un meilleur ajustement, fixez les goupilles "D" et les étagères #06 selon votre convenance.

Hay 3 orificios para un mejor ajuste, fije los pines "D" y los estantes #06 según su conveniencia.

D		04
---	--	----

17.

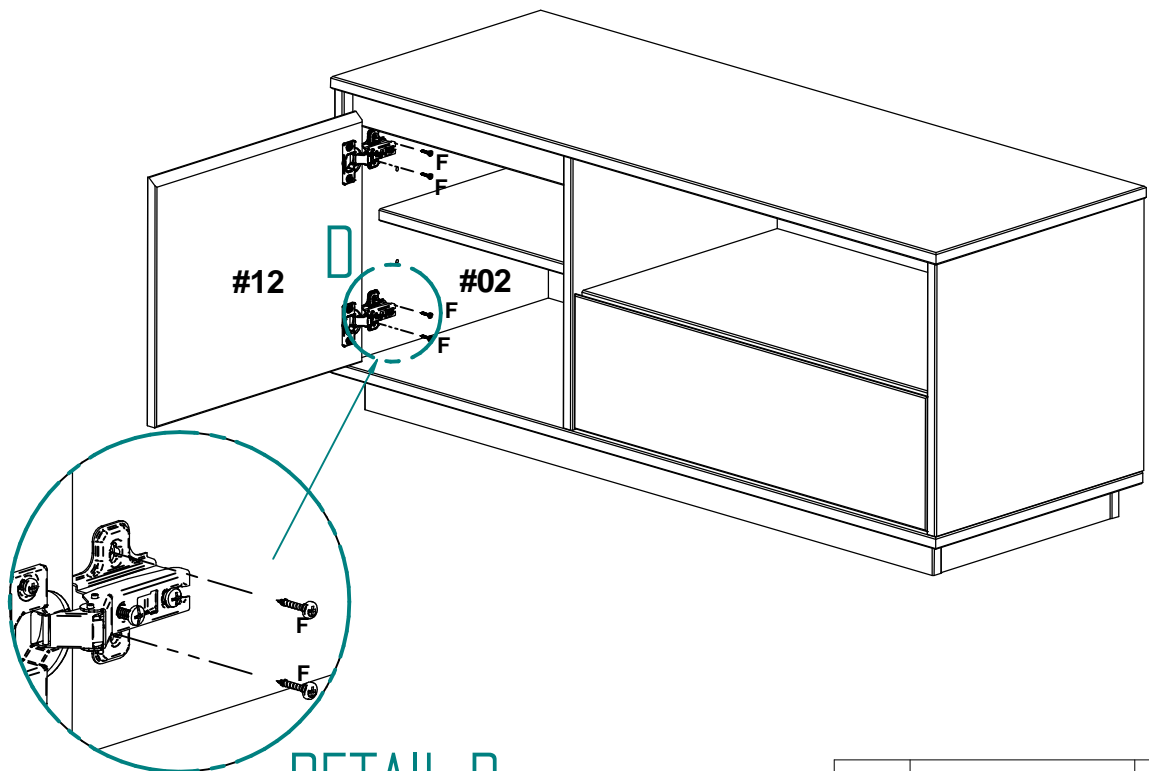

DETAIL D

F		04
---	--	----



18.

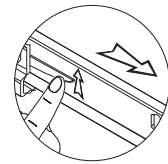
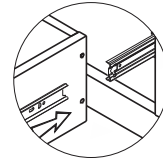
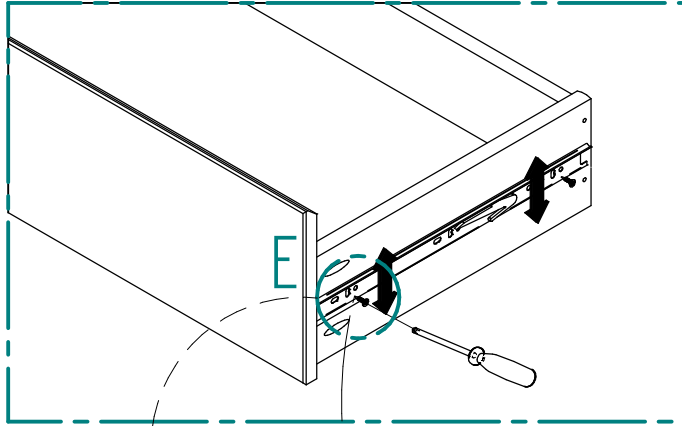

How to fit the drawers
Comment monter les tiroirs
Como montar los cajones

How to take out the drawers
Comment sortir les tiroirs
Como sacar los cajones

Height adjustment / Réglage de la hauteur /
Ajuste de altura

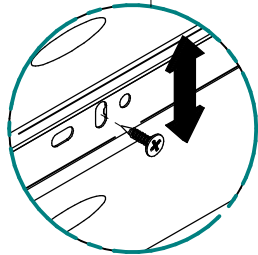

DETAIL E

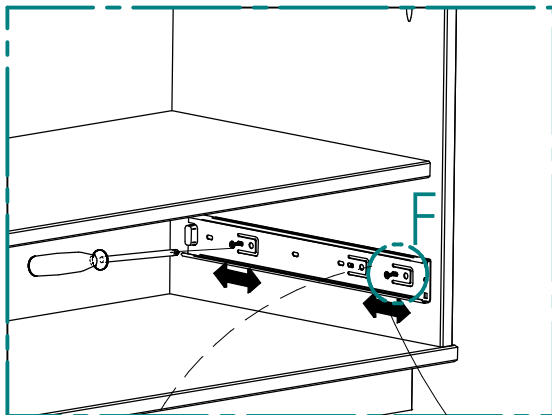
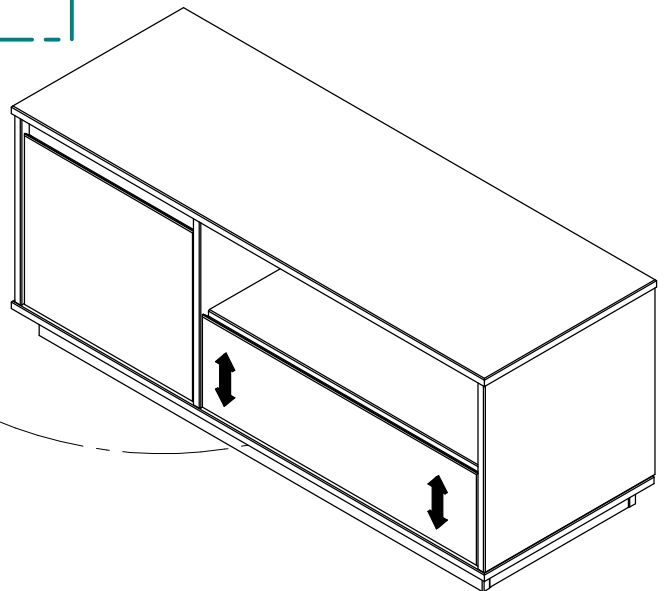

Depth adjustment / Réglage de la profondeur /
Ajuste de profundidad

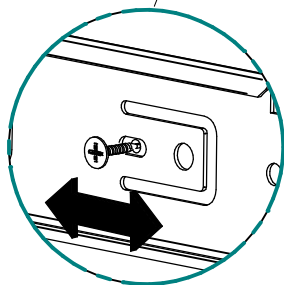

DETAIL F

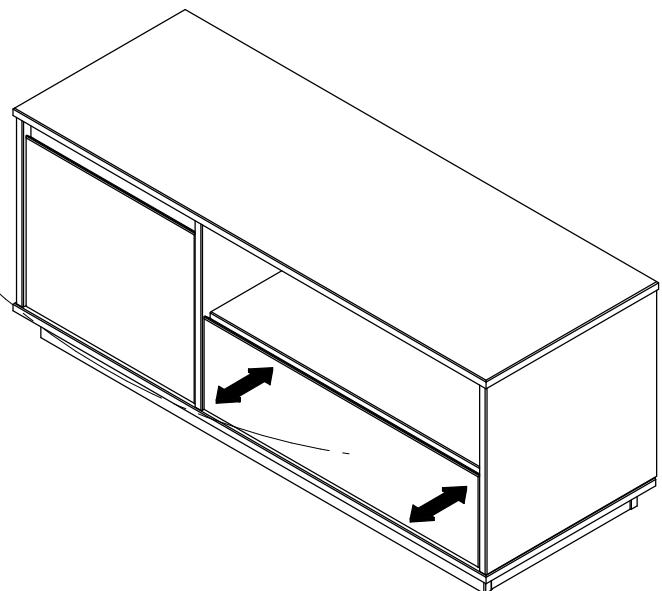



19.

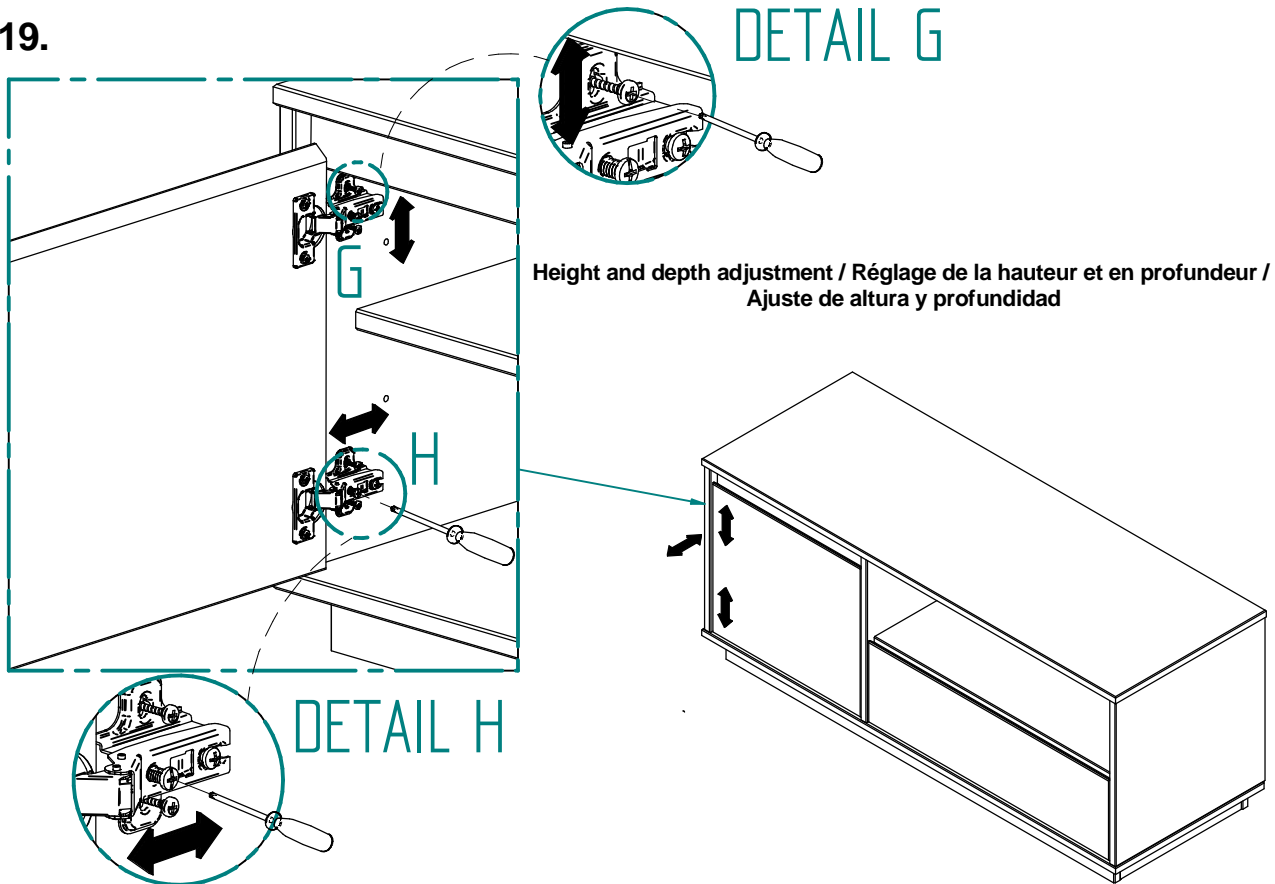

Height and depth adjustment / Réglage de la hauteur et en profondeur / Ajuste de altura y profundidad

20.

10 Kg	22 Lb
Drawer / Tiroir / Cajón	
10 Kg	22 Lb
Shelves / Des étagères / Estante /	
50 Kg	110 Lb
Top / Dessus / Tablero	

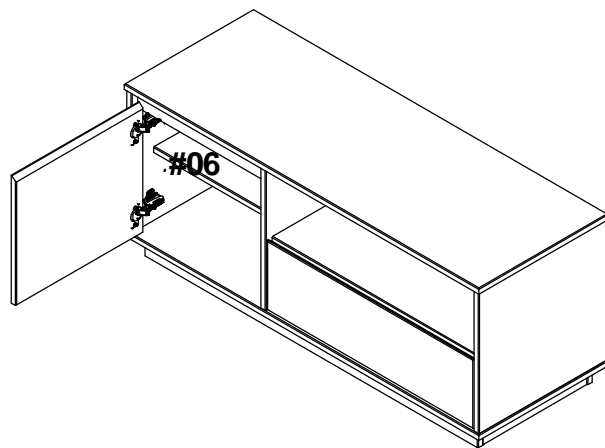

***** CAUTION ***** This stand is intended for use only with the products and maximum weights indicated. Use with other products or products heavier than the maximum weights indicated may result in instability causing possible injury.

Model: 826432WAL01U
Distributor/Manufacturer: Linon Home Decor Products, Inc.
Origin: BRAZIL

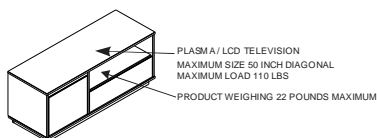

***** MISE EN GARDE ***** Ce meuble doit être utilisé seulement avec les produits et les poids maximums indiqués. L'usage avec d'autres produits ou des produits plus lourds que ceux indiqués peut nuire à la stabilité du meuble et entraîner des blessures.

Modèle: 826432WAL01U
Distributeur/Fabricant: Linon Home Decor Products, Inc.
Origine: BRÉSIL

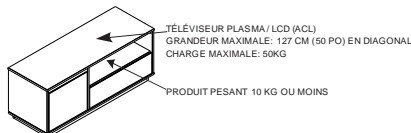

***** PRECAUCIÓN ***** Este mueble debe ser utilizado solamente con los productos y pesos máximos indicados. El uso con otros productos o con productos más pesados que los indicados puede afectar la estabilidad del mueble y causar lesiones.

Modelo: 826432WAL01U
Distribuidor/Fabricante: Linon Home Decor Products, Inc.
Origen: BRASIL





LIMITED 6 MONTHS WARRANTY

GARANTIE LIMITÉE DE 6 MOIS

GARANTÍA LIMITADA DE 6 MESES

WHAT IS COVERED

This product is covered under our manufacturer's 6 months limited warranty (Linon Home Décor Products). To ensure your complete satisfaction, this warrants to the original purchaser that the Linon supplied item is free from defects in material and workmanship, as of the date of purchase, and that it will, under normal use and proper care, remain so for six months after the date of purchase.

Replacement of missing or initially defective parts will be sent, at no charge, for a period of 30 days from the date of purchase with valid proof of purchase providing the parts are available in our warehouse and the item purchased is part of our current inventory.

WHAT IS NOT COVERED

It remains the customer's responsibility for freight and packaging charges to and from the customer service center. Labor and material charges to remove or replace parts under this warranty are not covered.

This warranty does not cover: Furniture used for commercial purposes, failures caused by improper installation assembly or by improper care, unreasonable or abusive use, freeze damage, acts of God, rust, purchased parts or returns freight and packaging charges. Proof of purchase (dated register receipt) is required for warranty claims.

HOW TO OBTAIN SERVICE

For further information, please contact our customer service department, c/o Linon Home Décor Products, Inc., between 9:00 AM and 5:00 PM Eastern Standard Time, Monday through Friday:

CUSTOMER SERVICE DEPARTMENT:

- 1) Email address:
consumersupport@linon.com
- 2) Toll free number:
1 - 800 - 262 - 1852

QU'EST-CE QUI EST COUVERT

Ce produit est couvert sous une garantie limitée de 6 mois offerte par le fabricant. Afin d'assurer votre entière satisfaction, cela garantit à l'acheteur original que le produit fourni est exempt de défauts de matériaux et de fabrication à compter de la date d'achat, et ce, sous des conditions d'utilisation normales et de soins adéquats, valide pendant six mois après la date d'achat.

Le remplacement de pièces manquantes ou défectueuses dès le départ sera envoyé, sans frais, pour une période de 30 jours suivant la date d'achat avec une preuve d'achat valide pourvu que les pièces soient disponibles dans notre entrepôt et que l'article acheté fait partie de notre inventaire actuel.

QU'EST-CE QUI N'EST PAS COUVERT

Il y a de la responsabilité du client de couvrir les frais de transport et d'emballage vers et à partir du centre de service après-vente. Les frais de la main-d'oeuvre et des matériaux pour retirer les pièces ou les remplacer sous cette garantie ne sont pas couverts.

Cette garantie ne couvre pas: les meubles utilisés à des fins commerciales, les défaillances causées par un mauvais assemblage ou entretien (sans dépasser les limites de poids), l'utilisation déraisonnable ou abusive, les dommages causés par le gel, la rouille, les frais de transport et d'emballage pour des pièces achetées ou retournées. Une preuve d'achat (reçu de caisse daté) est requise pour les réclamations sous garantie.

COMMENT FAIRE POUR OBTENIR DU SERVICE

Pour de plus amples renseignements, veuillez communiquer avec notre département du service à la clientèle, entre 9 h et 17 h HNE, du lundi au vendredi.

CENTRE DE SERVICE À LA CLIENTÈLE

- 1) Adresse de courriel:
consumersupport@linon.com
- 2) Numéro de téléphone sans frais:
1 - 800 - 262 - 1852

QUÉ ESTÁ CUBIERTO

Este producto está cubierto por la garantía limitada de 6 meses de nuestro fabricante. Para asegurar su total satisfacción, ésta garantiza al comprador original que el artículo proporcionado se encuentra libre de defectos materiales y de fabricación, a partir de la fecha de compra, y que permanecerá en tal estado, sometido a un uso normal y cuidados adecuados, durante los seis meses posteriores a la fecha de la compra.

Las partes faltantes o que presenten defectos al inicio de ese período de tiempo serán enviadas sin cargo, durante un lapso de 30 días a partir de la fecha de compra válido, siempre que las partes estén disponibles en nuestro almacén y el artículo adquirido sea parte de nuestra inventario actual.

QUÉ NO ESTÁ CUBIERTO

El cliente asumirá los costos de flete y empaque hacia y desde el centro de servicio de cliente. Los cargos de material y mano de obra para extraer o reemplazar partes en el marco de la garantía no están cubiertos.

Esta garantía no cubre: muebles utilizados con fines comerciales, fallas causadas por montaje de instalación inadecuados o uso indebido (se recomienda no exceder los límites de peso), uso no razonable o abusivo, daños por congelación, oxidación, partes compradas, flete de devolución y cargos de empaque. Se exigirá el comprobante de compra (la factura de registro con fecha) para hacer valer la garantía.

CÓMO OBTENER SERVICIO

Si desea más información, póngase en contacto con nuestro departamento de servicio al cliente, de lunes a viernes entre las 9:00 a.m y las 5:00 p.m., hora estándar de los Estados Unidos.

DEPARTAMENTO DE SERVICIO AL CLIENTE

- 1) Correo electrónico
consumersupport@linon.com
- 2) Número telefónico gratuito:
1 - 800 - 262 - 1852

826432WAL01U

MADE IN BRAZIL
FABRIQUÉ AU BRÉSIL
HECHO EN BRASIL

BR12 - 20451

PRODUCED BY :
TREBOLL MÓVEIS
TRAV. FELISBERTO DA SILVA S/N
FLORES DA CUNHA – RIO GRANDE DO SUL

Thank you for buying our product!

Join our social media family by following us and tagging us in your posts.

#LinonLiving



Instagram: @linonhomedecor



Facebook: linonhomedecor



Pinterest: Linon Home Décor Inc.



<https://www.instagram.com/linonhomedecor/>

<https://www.facebook.com/linonhomedecor>

<https://www.pinterest.com/linonhomedecor/> created/