

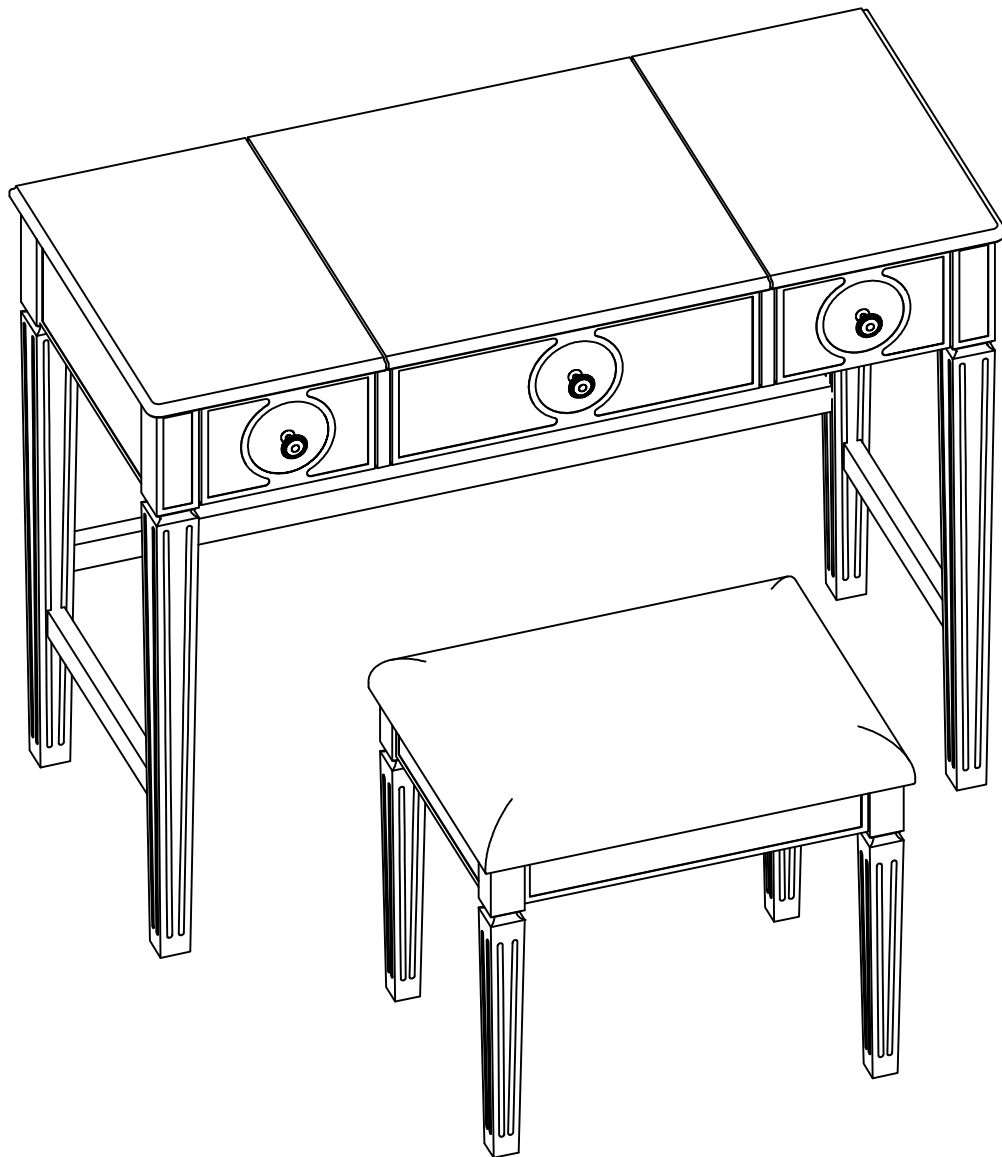

LINON HOME DECOR PRODUCTS, INC.

**VANITY SET - SILVER
ENSEMBLE DE COIFFEUSE, ARGENT
JUEGO DE TOCADOR, PLATA**

#580454SIL01U



HOA - 20146



We are here to help! Before you return it - contact us.

We do our best to ensure that your furniture arrives in excellent condition. In the event that a part is damaged or missing, Linon will provide you with available replacement parts at no charge within 30 days of purchase. Parts that are available for replacement are listed on the next page. In order to receive spare parts, at no charge you must provide proof of purchase within 30 days.

If you need assistance with assembly or replacement parts, please call Linon Customer Service, prior to returning the item to the store.

- Our office is open Monday – Friday 9am – 5pm, Eastern Standard Time.
- Our toll free customer service number is: 1 - 800 - 262 - 1852.
- Or visit our web site www.Linon.com to order spare parts and for care instructions on your newly purchased furniture.

Nous sommes là pour vous aider! Avant de retourner le produit, veuillez communiquer avec nous.

Nous faisons tout en notre pouvoir pour nous assurer que votre meuble arrivera en excellente condition. Si une pièce manque ou est endommagée, Linon vous fournira les pièces disponibles gratuitement dans un délai de 30 jours après l'achat. La liste des pièces disponibles pour remplacement se trouve à la page suivante. Pour recevoir les pièces de rechange sans frais, vous devez nous envoyer la preuve d'achat dans les 30 jours suivant l'achat.

Si vous avez besoin d'une pièce de rechange ou d'aide pour l'assemblage, veuillez communiquer avec le Service à la clientèle de Linon avant de retourner le produit au magasin.

- Nos bureaux sont ouverts du lundi au vendredi, de 9 h à 17 h, heure normale de l'Est.
- Le numéro sans frais pour joindre notre Service à la clientèle est le 1 - 800 - 262 - 1852.
- Vous pouvez aussi visiter notre site Web à www.Linon.com pour commander des pièces de rechange et pour obtenir les instructions d'entretien de votre nouveau meuble.

Estamos aquí para ayudarle! Antes de regresar el producto, comuníquese con nosotros.

Nos esforzamos para estar seguros que su mueble llegará en excelentes condiciones. Si una pieza le falta o está dañada, Linon reemplazará las piezas disponibles gratuitamente dentro de un plazo de 30 días después de la compra. La lista de piezas disponibles para ser reemplazadas se encuentra en la siguiente página. Para recibir las piezas de repuesto, sin cargo, debe enviar la prueba de compra en un plazo de 30 días después de ésta.

Si necesita ayuda para ensamblar su producto o para obtener piezas de repuesto, llame al Servicio al Cliente de Linon antes de devolver el artículo a la tienda.

- Nuestras oficinas están abiertas de lunes a viernes de las 9.00 a las 17.00 horas, hora del Este.
- Número de Servicio al Cliente gratuito: 1 - 800 - 262 - 1852.
- Para pedir piezas de repuesto y consultar las instrucciones de cuidados de su mueble recién adquirido, visite nuestro sitio Web www.Linon.com.







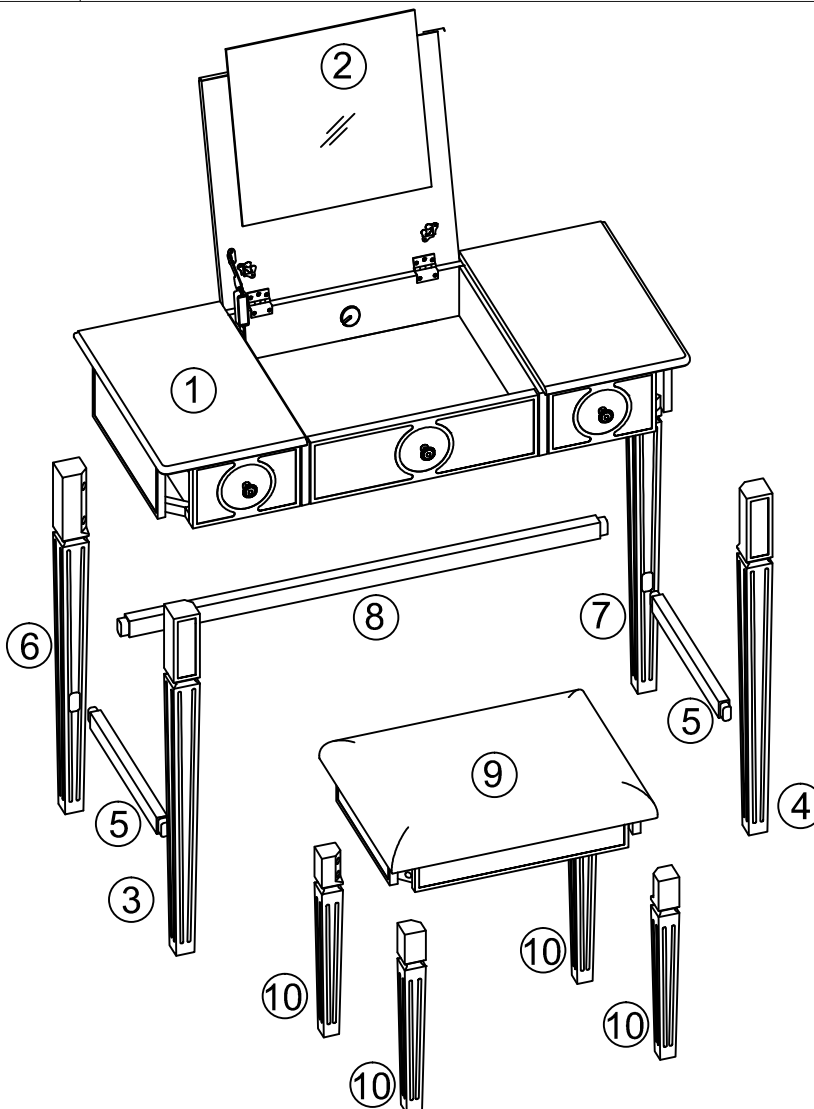

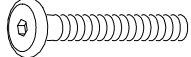

Parts list / Liste des pièces / Lista de piezas

580454SIL-01-HOA	Table - Top / Table - Dessus / Mesa - Encimera	01
580454SIL-02-HOA	Mirror / Miroir / Espejo	01
580454SIL-03-HOA	Table - front left leg / Table - pied gauche avant / Mesa - pata delantera izquierda	01
580454SIL-04-HOA	Table - front right leg / Table - pied droit avant / Mesa - pata delantera derecha	01
580454SIL-05-HOA	Table - side crossbar / Table - barre transversale latérale / Mesa - barra transversal lateral	02
580454SIL-06-HOA	Table - back left leg / Table - pied gauche arrière / Mesa - pata trasera izquierda	01
580454SIL-07-HOA	Table - back right leg / Table - pied droit arrière / Mesa - pata trasera derecha	01
580454SIL-08-HOA	Table - back crossbar / Table - barre transversale arrière / Mesa - barra transversal trasera	01
580454SIL-09-HOA	Stool - frame cushion / Tabouret - siège rembourré / Taburete - asiento acolchado	01
580454SIL-10-HOA	Stool - leg / Tabouret - pied / Taburete - pata	04
580454SIL-00-HOA	Hardware pack / Paquet contenant la quincaillerie / Juego de herramientas	01

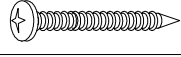





Hardware list / Liste des pièces / Lista de tornillería

A	Bolt (Ø1/4"x3") / Boulon / Perno		08
B	Bolt (Ø1/4"x2-3/8") / Boulon / Perno		08
C	Spring washer / Rondelle à ressort / Arandela elástica		16
D	Flat washer / Rondelle plate / Arandela plana		16
E	Round head screw (Ø5/16"x1-3/4") / Vis à tête ronde / Tornillo con cabeza redonda		06
F	Mirror holder / Support de miroir / Sujeta-espejo		02
G	Pan head screw (Ø3x12mm) / Vis à tête cylindrique / Tornillo con cabeza cilíndrica		04
H	Knob screw (Ø4x25mm) / Vis pour bouton / Tornillo para perilla		03
I	Plastic washer / Rondelle plastique / Arandela plástica		03
J	Metal knob / Bouton en métal / Perilla de metal		03

Tools required / Outils requis / Herramientas requeridas

Allen key / Clé hexagonale / Llave allen		Supplied / Fourni / Incluido
Phillips screwdriver / Tournevis phillips / Destornillador estándar		Not supplied / Non fourni / No incluido

IMPORTANT:

1. Do not tighten bolts completely until all bolts are completely lined up and inserted into holes / nuts.
2. Do not over tighten screws and bolts to avoid stripping.
3. Please use hand tools to assemble this product. Do not use power tools.
4. For your safety, assembly by two people is recommended.

IMPORTANT:

1. Ne serrez pas complètement les boulons jusqu'à ce que tous les boulons soient complètement alignés et insérés dans les trous / écrous.
2. Ne pas trop serrer les vis et les boulons pour éviter le décapage.
3. Utilisez des outils à main pour assembler ce produit. N'utilisez pas d'outils électriques.
4. Pour raisons de sécurité, l'assemblage devrait être fait par deux personnes.

IMPORTANTE:

1. No apriete completamente los pernos hasta que todos los tornillos estén alineados completamente y se inserten en los agujeros / tuercas.
2. No apriete demasiado los tornillos y los pernos para evitar que se pelen.
3. Utilice herramientas de mano para montar este producto. No utilice herramientas eléctricas.
4. Por razones de seguridad, el ensamblaje debería efectuarse por dos personas.



1.

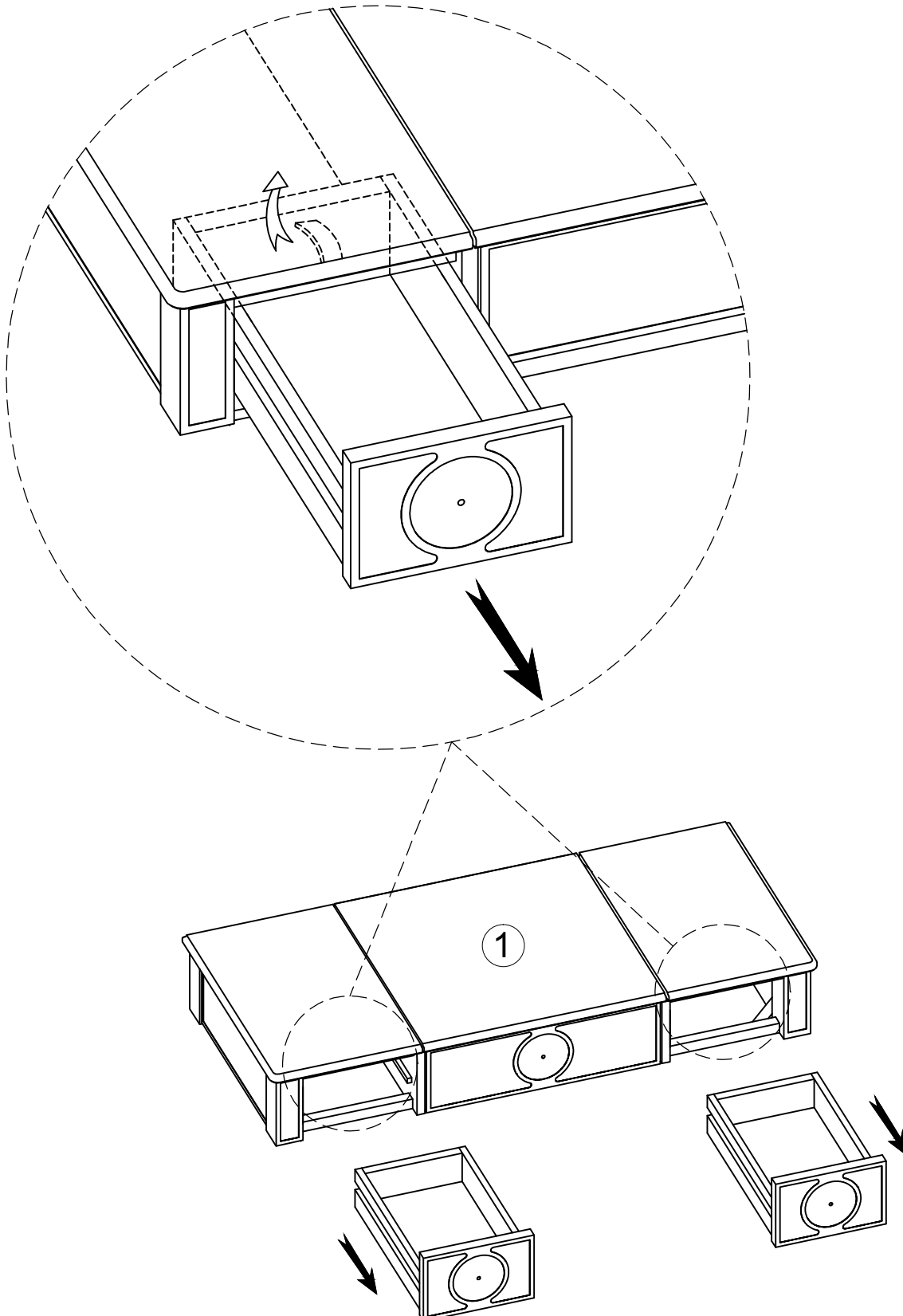

Please pull up plastic stopper to slide out the drawer for leg assembly.
Levez la butée en plastique pour glisser le tiroir et assembler le pied.
Levante el tope de plástico para deslizar el cajón y ensamblar la pata.



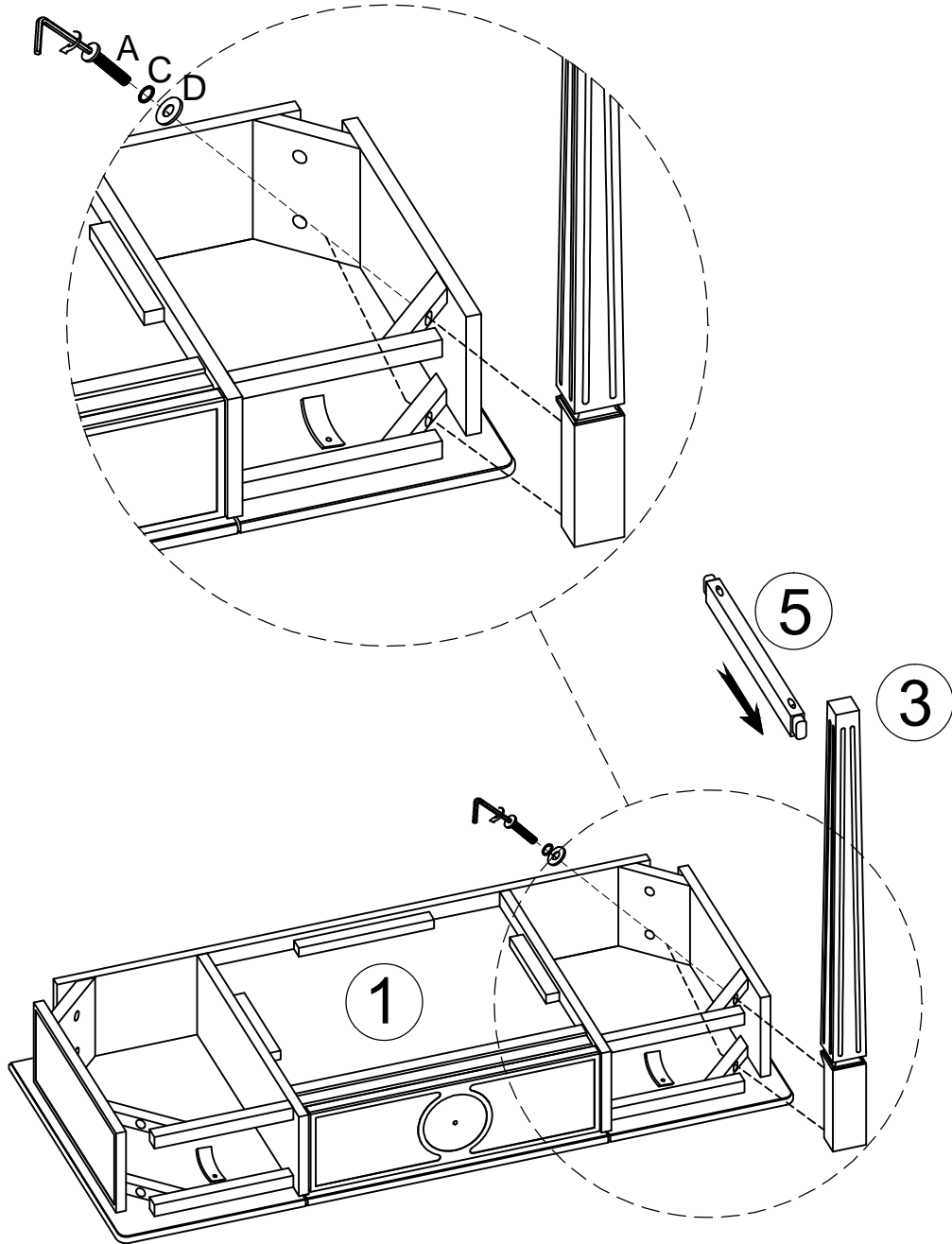

2.





A		2
C		2
D		2

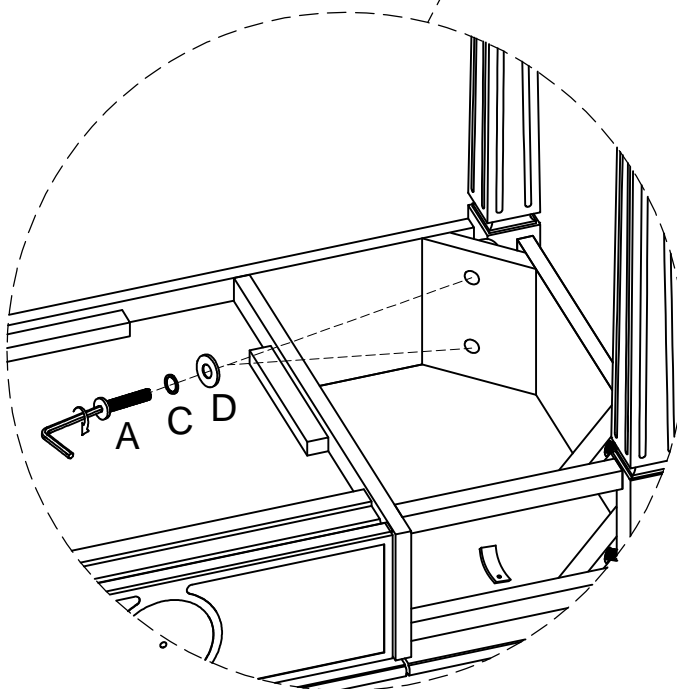
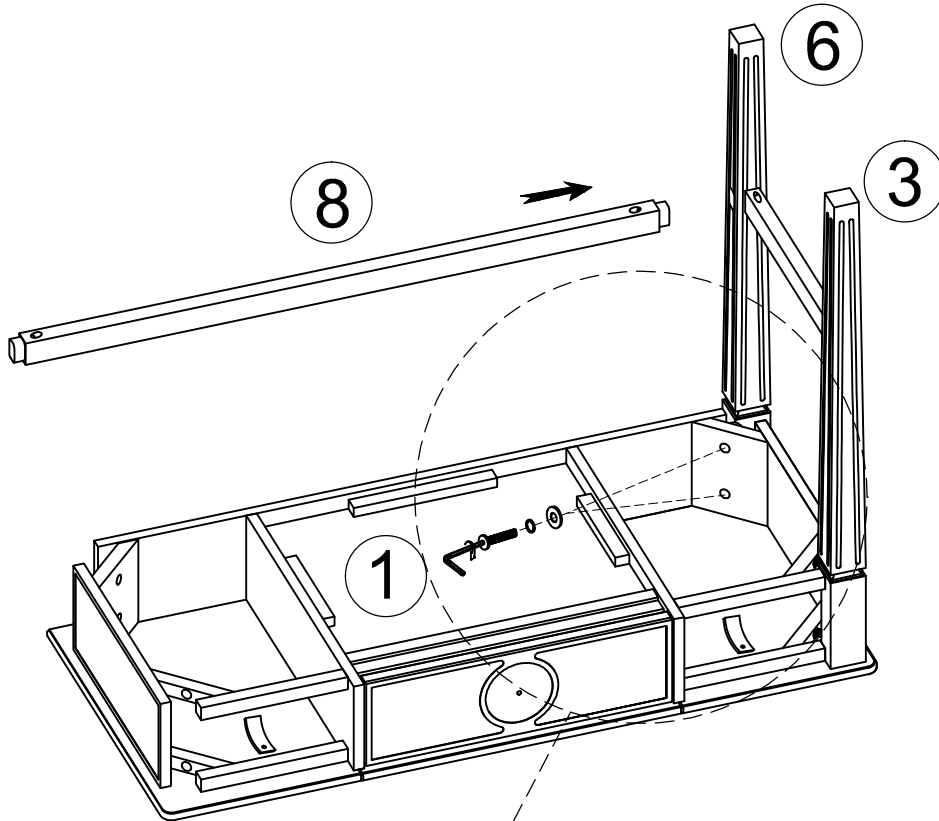

3.





A		2
C		2
D		2

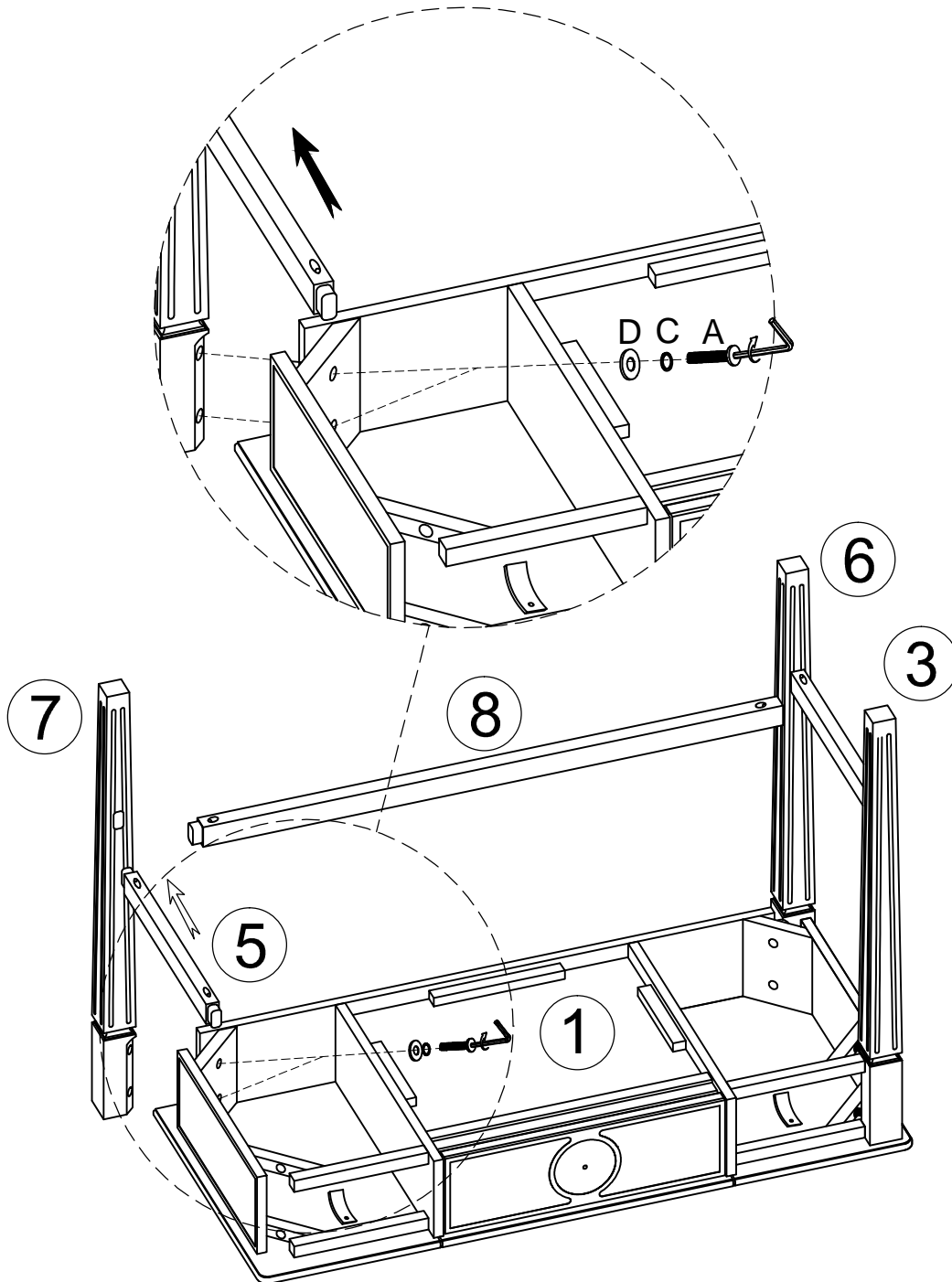

4.





A		2
C		2
D		2

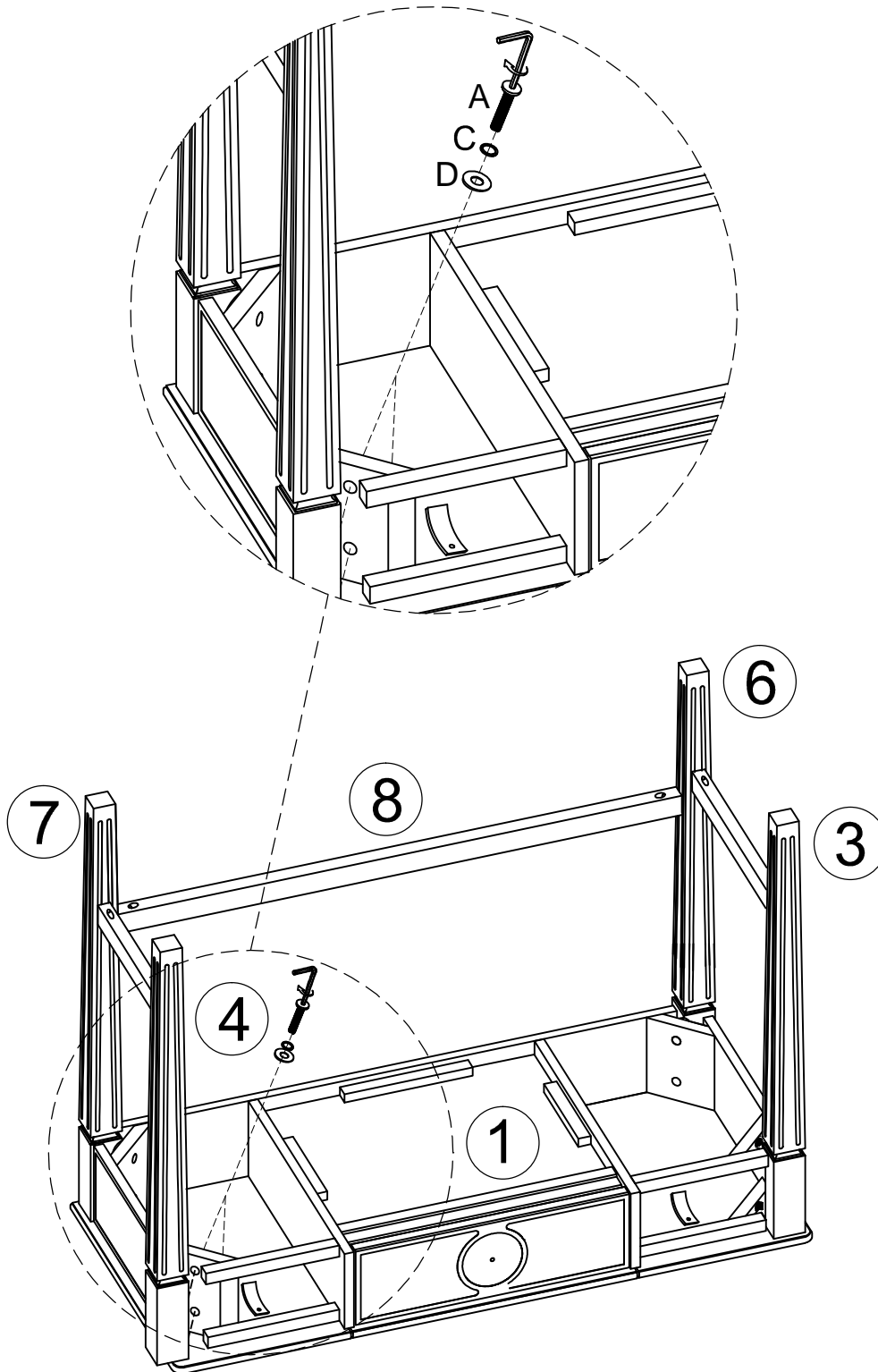

5.



A		2
C		2
D		2



6.

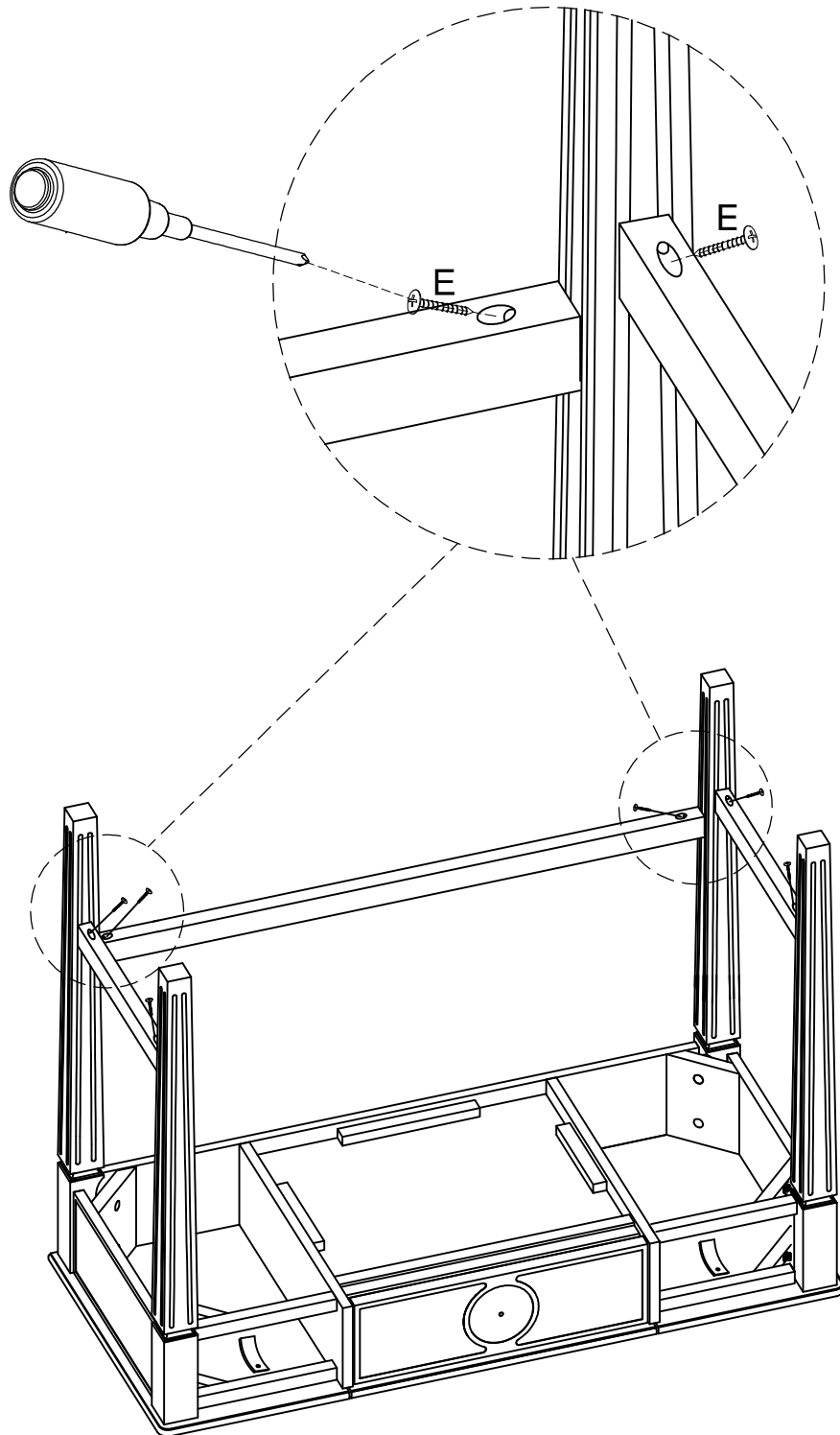

E		6
---	--	---

7.

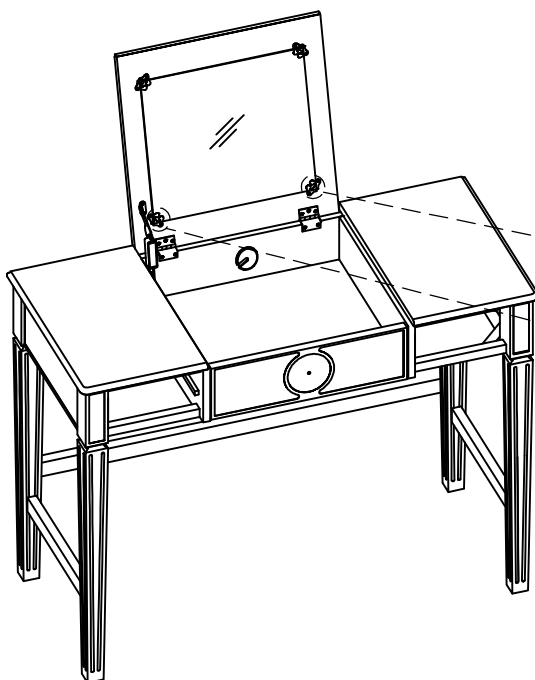
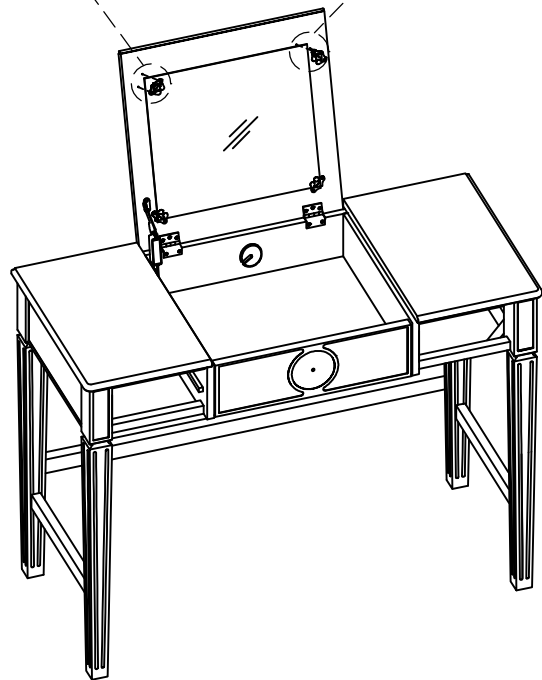
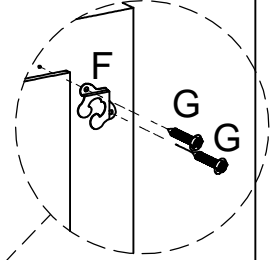
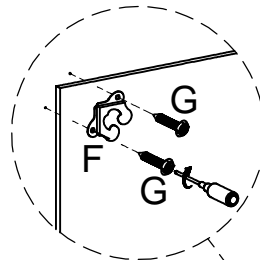
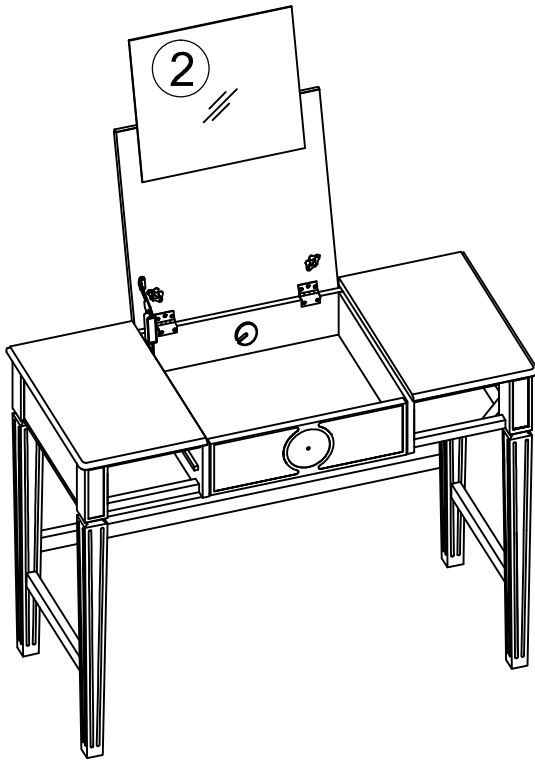

Tighten the bottom mirror holders.
 Serrez les supports inférieurs du miroir.
 Apriete los soportes inferiores del espejo.

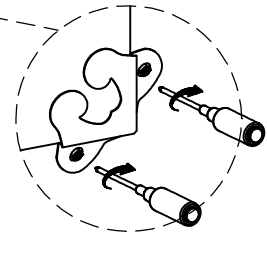
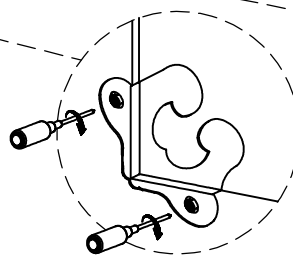

F		2
G		4



8.

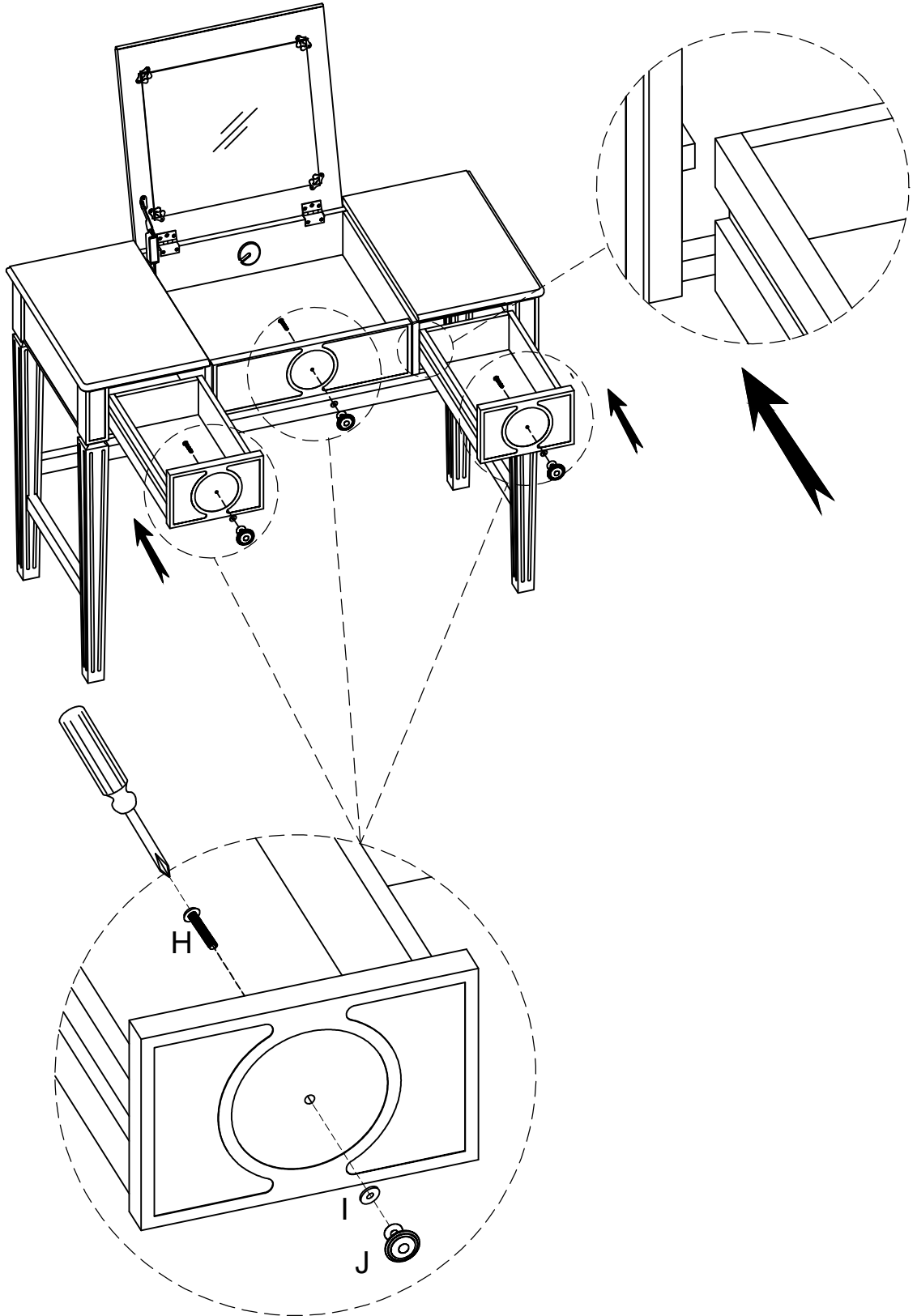



H		3
I		3
J		3

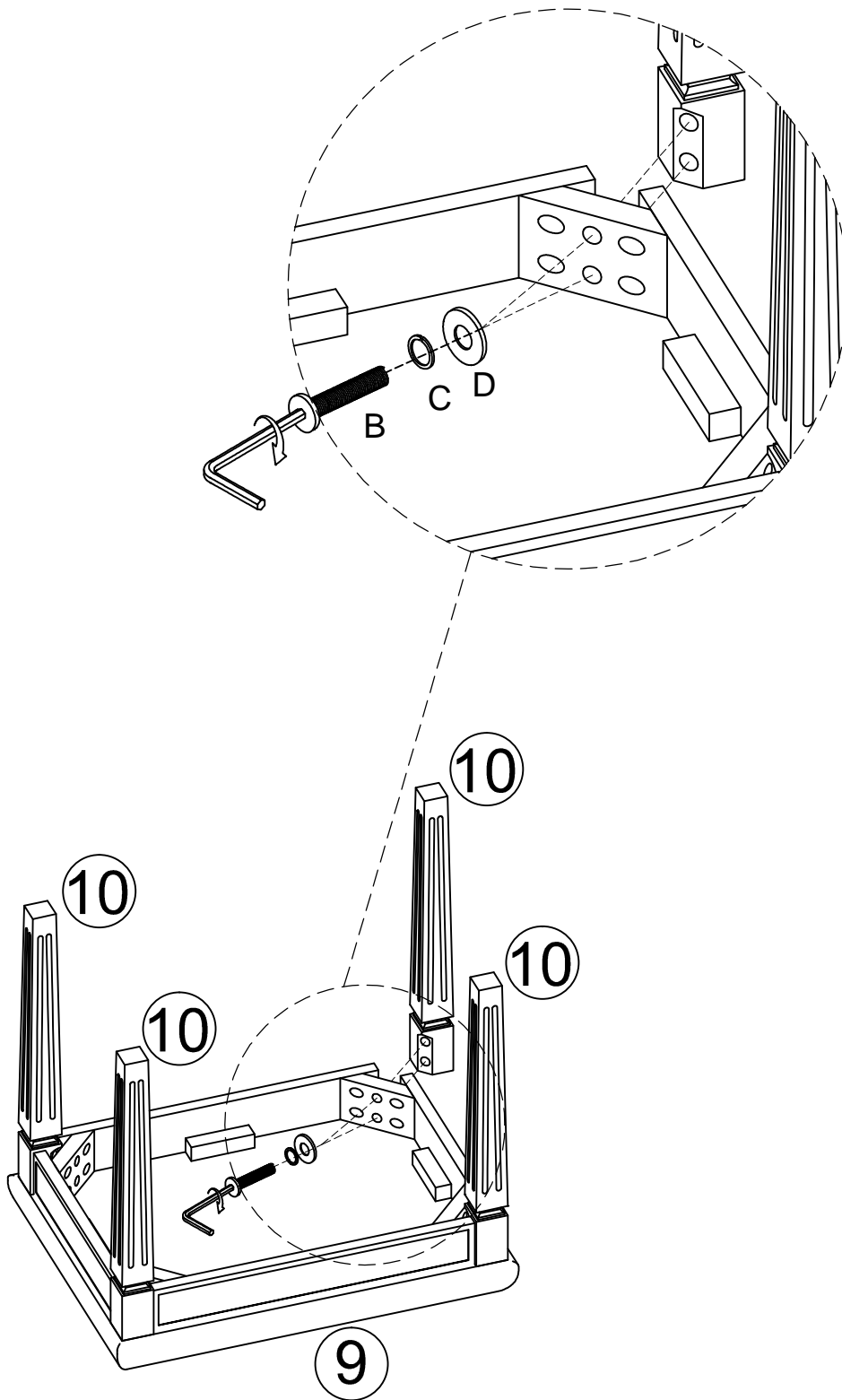

9.



B		8
C		8
D		8





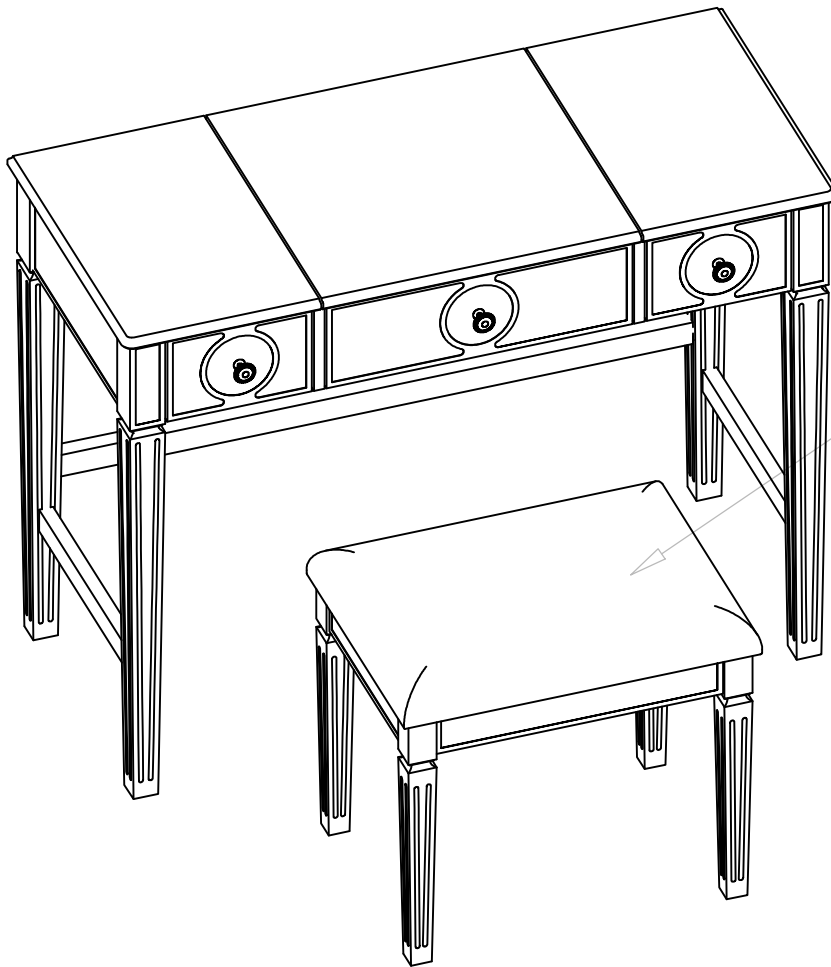

**COMPLETED ASSEMBLY
ASSEMBLAGE TERMINÉ
ENSAMBLAJE TERMINADO**



WEIGHT LIMITS : 275 LBS
POIDS LIMITE : 275 LBS
LÍMITE DE PESO : 275 LBS

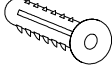
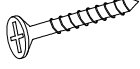

 Strap Courroies Abrazadera de sujeción A (1pc)	 Mounting Bracket Support de montage Ménsula de montaje B (2pcs)	 Wall Anchor Ancrages muraux Anclaje de pared C (2pcs)	 Short Screw Vis courte Tornillo corto D (2pcs)	 Long Screw Vis longue Tornillo largo E (2pcs)
--	---	---	--	---





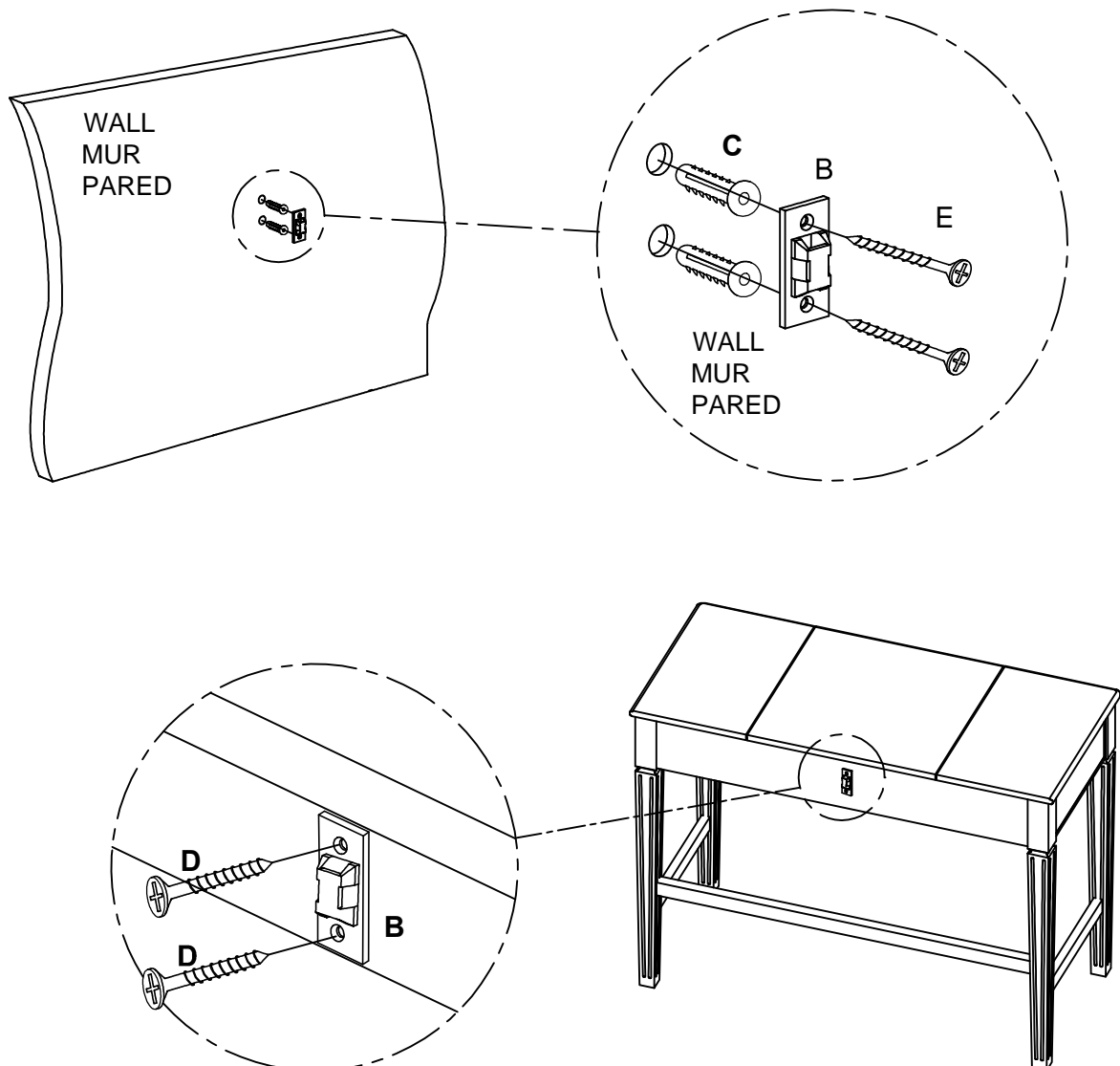

PLEASE NOTE: For your safety, to prevent the danger of this unit tipping over, it is important that the wall anchors are properly attached.

S'IL VOUS PLAÎT NOTE: Pour votre sécurité, pour éviter le danger de cette unité de basculement, il est important que les chevilles sont correctement fixés.

NOTA: Para su seguridad, para evitar el peligro de esta unidad se vuelque, es importante que los anclajes de pared estén bien fijados.





⚠ WARNING	⚠ AVERTISSEMENT	⚠ ADVERTENCIA
 <p>Children have died from furniture tipover. To reduce the risk of furniture tipover:</p> <ul style="list-style-type: none"> • ALWAYS install tipover restraint provided. • NEVER put a TV on this product. • NEVER allow children to stand, climb or hang on drawers, doors, or shelves. • NEVER open more than one drawer at a time. • Place heaviest items in the lowest drawers. 	 <p>Des enfants sont morts quand un meuble s'est renversé sur eux. Pour prévenir le basculement du meuble:</p> <ul style="list-style-type: none"> • Installez TOUJOURS le dispositif fourni pour prévenir le basculement. • Ne placez JAMAIS un téléviseur sur ce produit. • Ne laissez JAMAIS un enfant se tenir debout ou monter sur un tiroir, une porte ou une tablette, ni s'y accrocher. • N'ouvrez JAMAIS plus d'un tiroir à la fois. • Placez les objets les plus lourds dans les tiroirs les plus bas. 	 <p>Un mueble que se vuelca puede provocar la muerte de un niño. Para reducir el riesgo de volcadura del mueble:</p> <ul style="list-style-type: none"> • Instale SIEMPRE los dispositivos antivuelco proporcionados. • NUNCA coloque un televisor sobre este mueble. • NUNCA permita que un niño suba sobre un cajón, una puerta o un estante ni que se cuelgue de dichas piezas. • NUNCA abra más de un cajón a la vez. • Guarde los artículos más pesados en los cajones inferiores.
 <p><i>This is a permanent label. Do not remove!</i></p>	 <p><i>Cette étiquette est permanente. Ne l'enlevez pas!</i></p>	 <p><i>Esta etiqueta es permanente. No la quite.</i></p>

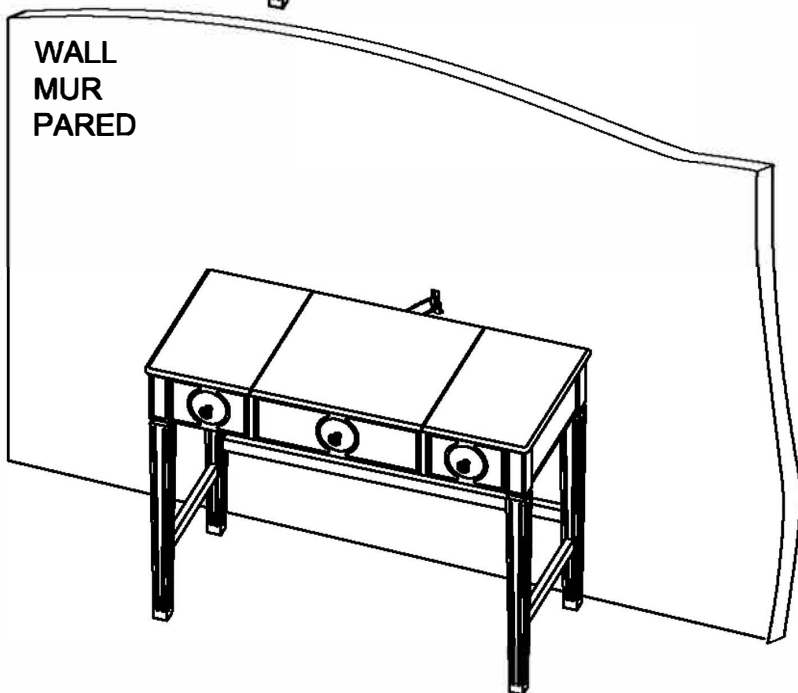
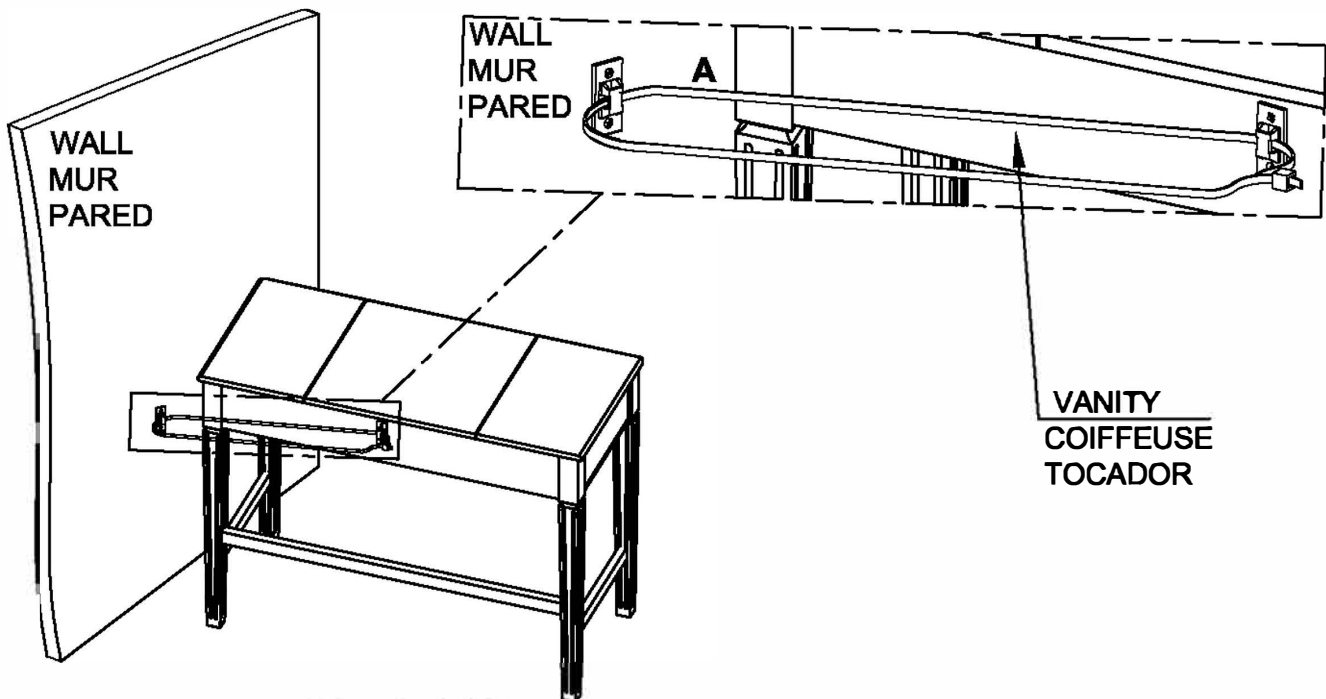



LIMITED 6 MONTHS WARRANTY

GARANTIE LIMITÉE DE 6 MOIS

GARANTÍA LIMITADA DE 6 MESES

WHAT IS COVERED

This product is covered under our manufacturer's 6 months limited warranty (Linon Home Décor Products). To ensure your complete satisfaction, this warrants to the original purchaser that the Linon supplied item is free from defects in material and workmanship, as of the date of purchase, and that it will under normal use and proper care, remain so for six months after the date of purchase.

Replacement of missing or initially defective parts will be sent, at no charge, for a period of 30 days from the date of purchase with valid proof of purchase providing the parts are available in our warehouse and the item purchased is part of our current inventory.

WHAT IS NOT COVERED

It remains the customer's responsibility for freight and packaging charges to and from the customer service center. Labor and materil charges to remove or replace parts under this warranty are not covered.

This warranty does not cover: Furniture used for commercial purposes, failures caused by improper installation assembly or by improper care, unreasonnable or abusive use, freeze damage, acts of God, rust, purchased parts or return freight and packaging charges. Proof of purchase (dated register receipt) is required for this warranty claims.

HOW TO OBTAIN SERVICE

For further information, please contact our customer service department, c/o Linon Home Décor Products, Inc., between 9:00 AM and 5:00 PM Eastern Standard Time, Monday through Friday:

CUSTOMER SERVICE DEPARTMENT:

- 1) Email address:
consumersupport@linon.com
- 2) Toll free number:
1 - 800 - 262 - 1852

#580454SIL01U

MADE IN VIETNAM
FABRIQUÉ AU VIETNAM
HECHO EN VIETNAM

HOA - 20146

QU'EST-CE QUI EST COUVERT

Ce produit est couvert sous une garantie limitée de 6 mois offerte par le fabricant. Afin d'assurer votre entière satisfaction, cela garantit à l'acheteur original que le produit fourni est exempt de défauts de matériaux et de fabrication à compter de la date d'achat, et ce, sous des conditions d'utilisation normales et de soins adéquats, valide pendant six mois après la date d'achat.

Le remplacement de pièces manquantes ou défectueuses dès le départ sera envoyé, sans frais, pour une période de 30 jours suivant la date d'achat avec une preuve d'achat valide pourvu que les pièces soient disponibles dans notre entrepôt et que l'article acheté fait partie de notre inventaire actuel.

QU'EST-CE QUI N'EST PAS COUVERT

Il y va de la responsabilité du client de ouvrir les frais de transport et d'emballage vers et à partir du centre de service après-vente. Les frais de la main-d'oeuvre et des matériaux pour retirer les pièces ou les remplacer sous cette garantie ne sont pas couverts.

Cette garantie ne couvre pass: les meubles utilisés à des fins commerciales, les défaillances causées par un mauvais assemblage ou entretien(sans dépasser les limites de poids). l'utilisation déraisonnable ou abusive, les dommages causés par le gel, la rouille, les frais de transport et d'emballage pour des pièces achetées ou retournées. Une preuve d'achat(reçu de caisse daté) est requise pour les réclamations sous garantie.

COMMENT FAIRE POUR OBTENIR DU SERVICE

Pour de plus amples renseignements, veuillez communiquer avec notre département du service à la clientèle, entre 9h et 17h HNE, du lundi au vendredi.

CENTRE DE SERVICE À LA CLIENTÈLE:

- 1) Adresse de courriel:
consumersupport@linon.com
- 2) Numéro de téléphone sans frais
1 - 800 - 262 - 1852

QUÉ ESTÁ CUBIERTO

Este producto está cubierto por la garantía limitada de 6 meses de nuestro fabricante. Para asegurar su total satisfacción, ésta garantiza al comprador original que el artículo proporcionado se encuentra libre de defectos materiales y de fabricación, a partir de la fecha de compra, y que permanecerá en tal estado, sometido a un uso normal y cuidados adecuados, durante los seis meses posteriores a la fecha de la compra.

Las partes faltantes o que presenten defectos al inicio de ese período de tiempo serán enviadas sin cargo, durante un lapso de 30 días a partir de la fecha de compra, mediante la presentación de un comprobante de compra válido, siempre que las partes estén disponibles en nuestro almacén y el artículo adquirido sea parte de nuestro inventario actual.

QUE' NO ESTÁ CUBIERTO

El cliente asumirá los costos de flete y empaque hacia y desde el centro de servicio de cliente. Los cargos de material y mano de obra para extraer o mreemplazar partes en el marco de la ganantía no están cubiertas.

Esta garantía no cubre: muebles utilizados con fines comerciales, fallas causadas por montaje de instalación inadecuados o uso indebido(se recomienda no exceder los límites de peso), uso no razonable o abusivo, daños por congelación, oxidación, partes compradas, flete de devolución y cargos de empaque. Se exigirá el comprobante de compra(la factura de registro con fecha) para hacer valer la garantía.

CÓMO OBTENER SERVICIO

Si desea más información, póngase en contacto con nuestro departamento de servicio al cliente, de lunes a viernes entre las 9:00 am. y las 5:00pm, hora estándar de los Estados Unidos.

DEPARTAMENTO DE SERVICIO AL CLIENTE:

- 1) Correo electrónico:
consumersupport@linon.com
- 2) Número telefónico gratuito:
1 - 800 - 262 - 1852